

■ GENERAL DESCRIPTION

The PT4401/2 is a series of White/Blue LED drivers, with PT4401 capable of driving three LEDs and PT4402 driving four LEDs. There is no external component needed, which helps to simplify the system design and lower the system cost significantly. The circuit is optimized to provide over 90% efficiency. The PT4401/2 is ideal to drive white LEDs used for Li-ion battery powered LCD displays. The LED brightness can be adjusted in real time through a PWM signal at the EN pin. The target end applications are small color LCD displays in mobile phones, smart phone, digital cameras, PDA etc. PT4401 is available in SOT-23-6 package and PT4402 in MSOP-8 package, respectively.

■ FEATURES

- No external component required
- Fixed 20mA or 15mA sinking current
- Individual current sink circuit for each output to prevent short/open circuit on LEDs
- PTC LED current for luminosity compensation
- 3 channels (PT4401/SOT23-6) and 4 channels (PT4402/MSOP-8) available
- PWM tuned LED brightness through EN pin
- Supply voltage range 2.7V~6.0V
- 0.1uA standby current

■ APPLICATIONS

- Mobile phone
- PDAs
- MP3s

■ TYPICAL APPLICATION

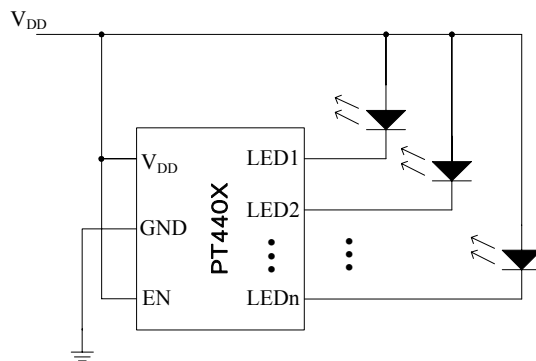

ORDERING INFORMATION

PT4401EPPP-nn

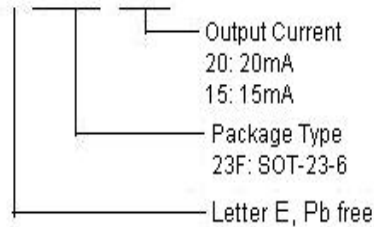

PT4402EPPP-nn

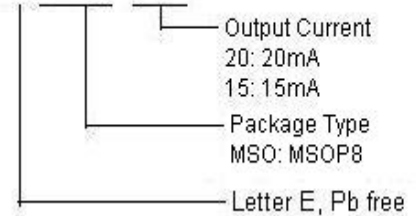

PIN CONFIGURATION

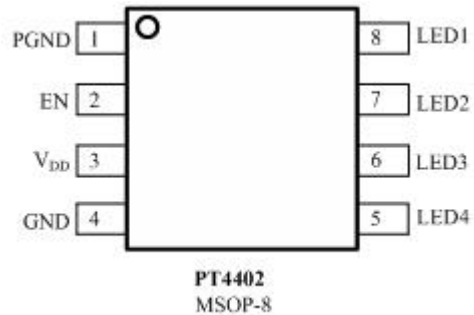
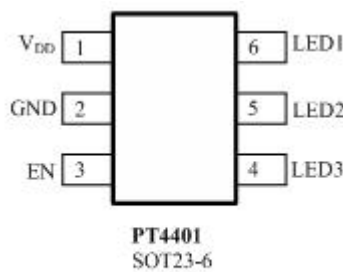

PIN DESCRIPTIONS

Pin No.		Symbol	Description
SOT-23-6	MSOP8		
1	3	V _{DD}	Power Supply
2	4	GND	Ground
	1	PGND	Power Ground
3	2	EN	Enable Input Logic, Enable High
4~6	5~8	LED1~3/4	Output Pins. Connected to LED's Cathode.

ABSOLUTE MAXIMUM RATINGS

Symbol	PARAMETER	VALUE
V _{DD}	V _{DD} Supply Voltage	-0.3~6.5V
V _{LEDN}	V _{LED} Output Voltage	-0.3~ V _{IN} V
V _{EN}	V _{EN} Pin Input Voltage	-0.3~5.5V
P _{D1}	Maximum Power Dissipation, SOT-23-6	586mW
P _{D2}	Maximum Power Dissipation, MSOP8	695mW
T _{jun}	Junction Temperature	150°C
T _{STG}	Storage Temperature	-50~150°C
T _{SOLDER}	Soldering Temperature	260°C, 10s

RECOMMENDED OPERATING RANGE

Symbol	PARAMETER	VALUE
V _{DD}	V _{DD} Range	-0.3~6.0V
V _{EN}	V _{EN} Range	-0.3~(V _{IN} +0.3)<5.5V
θ _{JA}	Thermal Resistance, SOT-23-6	220°C/W
	Thermal Resistance, MSOP8	180°C/W
T _{OPT}	Operation Temp.	-40~85°C

■ ELECTRICAL CHARACTERISTICS

($V_{DD} = 3.7V$, $V_{EN} = V_{DD}$, $T_A = +25^\circ C$, unless otherwise specified)

Symbol	Parameter	Conditions	Min.	Typ.	Max.	Unit
V_{DD}	Input Voltage		2.7		6.0	V
I_{LED}	LED pin Maximum Sink Current				20	mA
V_{DO}	LED pin Drop-Out Voltage	$I_{LED(nom)}=20mA$, $V_{LED}@I_{LED}=90\% \times I_{LED(nom)}$		75	90	mV
ΔI_{LED}	LED pin Sink Current Tolerance	$I_{LED(nom)}=20mA$, $I_{LED}/I_{LED(nom)}$			± 5	%
δI_{LED}	LED pin Sink Current Deviation	$[\text{Max}(I_{LEDn}) - \text{Min}(I_{LEDn})] / \text{Average}(I_{LEDn})$			± 3	%
I_{DD}	Supply Current			260	380	μA
I_{SHUT}	Shutdown Current			0.1	1	μA
I_{EN}	Input Leakage at EN pin	EN = 0V		1		nA
V_{IL}	Input Low Level at EN pin				0.4	V
V_{IH}	Input High Level at EN pin		2.0			V

■ BLOCK DIAGRAM

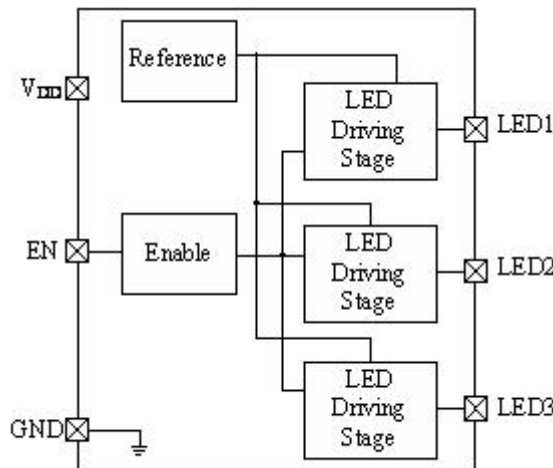

■ APPLICATION INFORMATION

● Supply Voltage and Li-ion Battery Low Warning

The PT4401/2 works with supply voltage range from 2.7V to 6V. The white/blue LED forward voltage is in the range of 2.9V to 3.5V at 20mA current. The supply voltage range and LED forward voltage (Vf) should be set to fully utilize Li-ion battery energy. For example, the maximum white LED forward voltage shall be limited to lower than 3.2V (@ 20mA) when Li-ion battery discharges to 3.275V (normally around 1% ~ 3% power left in the battery). When Li-ion battery voltage is below the preset voltage level, the LED current (namely, the brightness) starts to decrease.

● Enable (EN Pin)

The EN pin of the PT4401/2 serves two functions. One is to enable or disable the device. The other one is the tuning of LED currents if a pulse width modulated (PWM) signal is applied to the pin. As a result, the brightness of LEDs is adjusted through a PWM signal generated from a base-band or MCU chip. The PWM frequency should be less than 5KHz in order to keep the LED current matching between LEDs. The PWM duty cycle can be changed from 5% to 95%

■ TYPICAL PERFORMANCE CHARACTERISTICS

1. LED Current vs. Supply Voltage

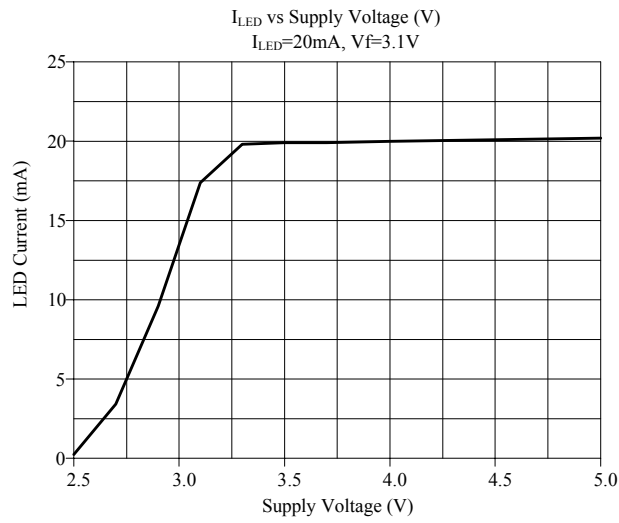

Note: V_f is the forward Voltage of LED

2. PWM Dimming Control through EN pin

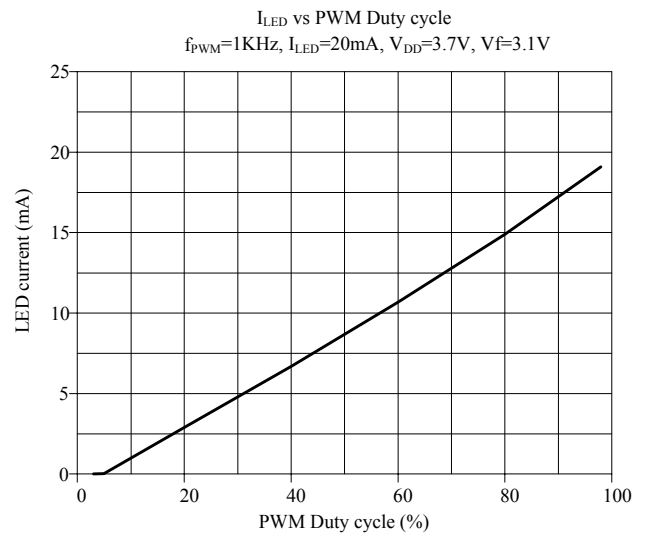

Note: V_f is the forward Voltage of LED

3. Temperature Characteristics

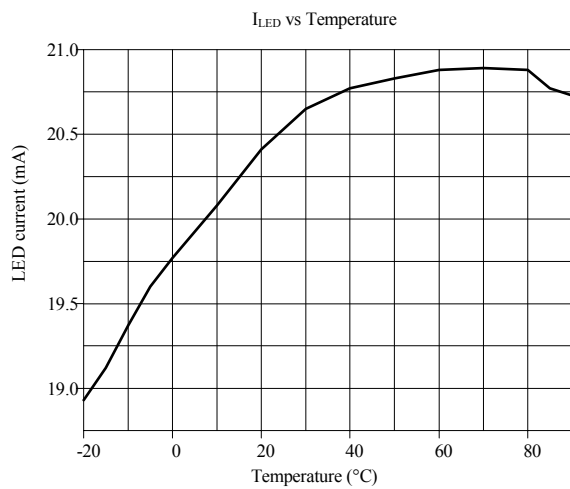

PACKAGE INFORMATION

1. SOT-23-6

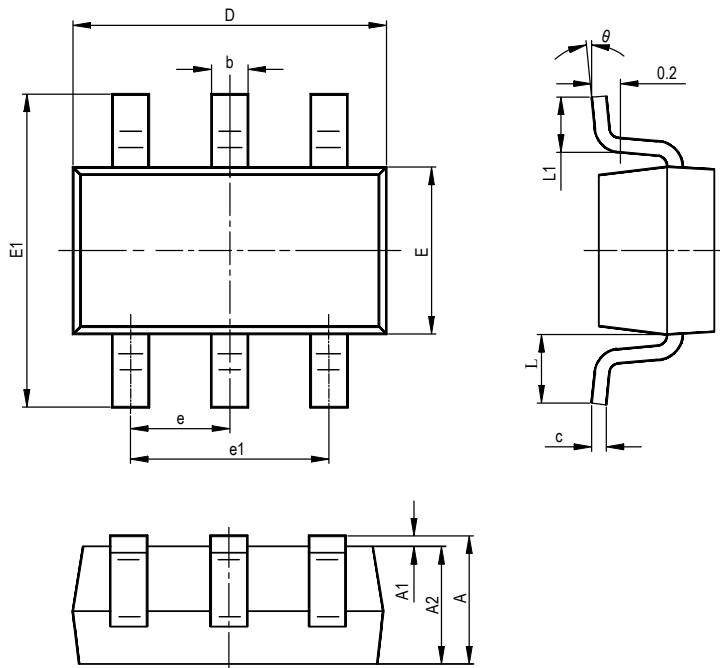

Symbol	Millimeters		Inches	
	Min	Max	Min	Max
A	1.050	1.250	0.041	0.049
A1	0.000	0.100	0.000	0.004
A2	1.050	1.150	0.041	0.045
b	0.300	0.400	0.012	0.016
c	0.100	0.200	0.004	0.008
D	2.820	3.020	0.111	0.119
E	1.500	1.700	0.059	0.067
E1	2.650	2.950	0.104	0.116
e	0.950TYP		0.037TYP	
e1	1.800	2.000	0.071	0.079
L	0.700REF		0.028REF	
L1	0.300	0.600	0.012	0.024
θ	0°	8°	0°	8°

2. MSOP8

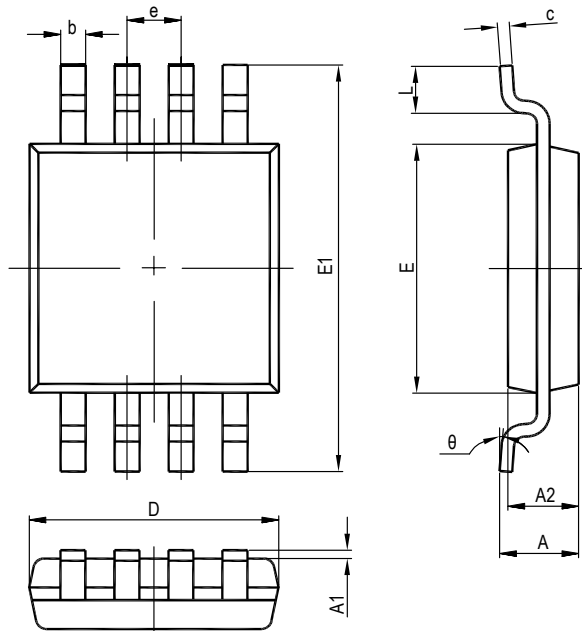

Symbol	Millimeters		Inches	
	Min	Max	Min	Min
A	0.820	1.100	0.032	0.043
A1	0.020	0.150	0.001	0.006
A2	0.750	0.950	0.030	0.037
b	0.250	0.380	0.010	0.015
c	0.090	0.230	0.004	0.009
D	2.900	3.100	0.114	0.122
e	0.650(BSC)		0.026(BSC)	
E	2.900	3.100	0.114	0.122
E1	4.750	5.050	0.187	0.199
L	0.400	0.800	0.016	0.031
θ	0°	6°	0°	6°