

DESCRIPTION

PT6607 is a 64-channel common driver for dot matrix liquid crystal graphic display system. It utilizes CMOS technology and provides 64 shift registers and 64 output drivers. PT6607 generates the timing signal which controls the PT6608 segment driver. Pin assignments and application circuit are optimized for easy PCB Layout and cost saving advantages.

FEATURES

- CMOS technology
- 64 channel outputs
- Provides 64 bits shift register in the internal LCD driver circuit
- Internal timing generator circuit for dynamic display
- Selectable master/slave mode
- Power supply: $+5V \pm 10\%$
- LCD driving voltage: 8V to 17V ($V_{DD} - V_{EE}$)
- LCD duty: 1/48, 1/64, 1/96, 1/128
- Available in C.O.B. or 100-pin, QFP package
- Interface: common driver -- PT6607
segment driver -- PT6608
controller -- MPU

APPLICATION

- Peripheral devices

BLOCK DIAGRAM

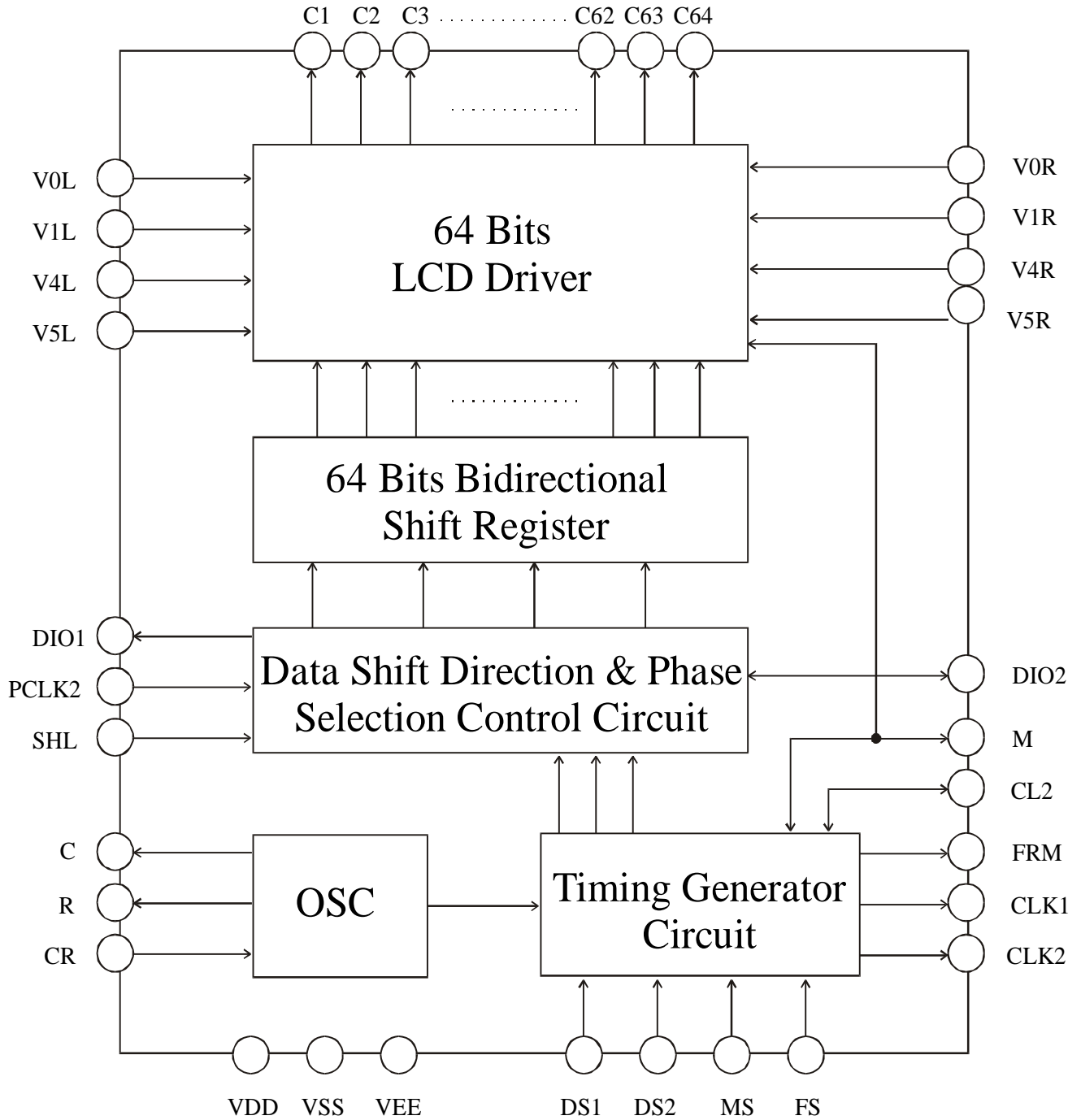



LCD Driver IC

Preliminary

PT6607

PIN CONFIGURATION

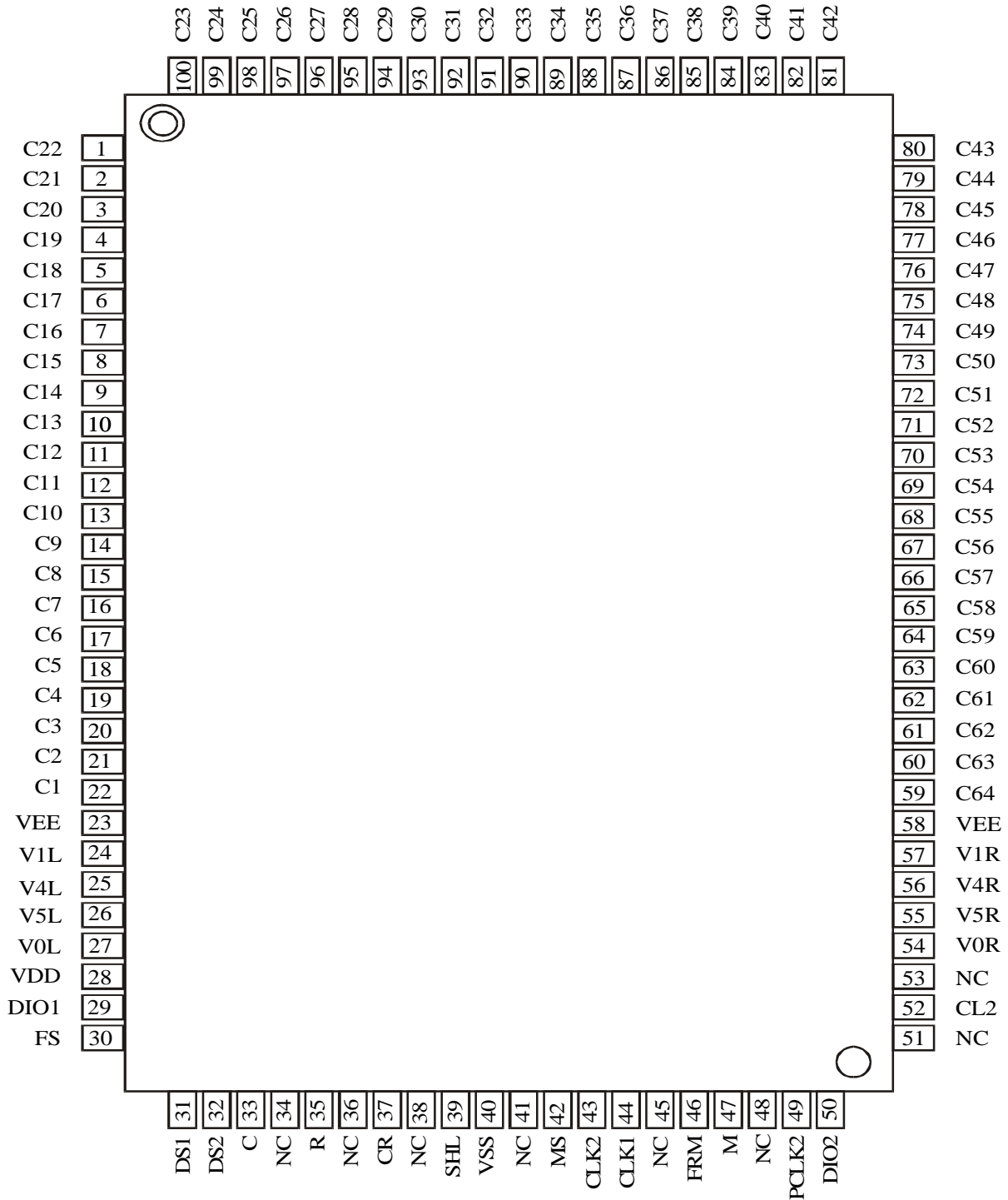



APPLICATION CIRCUIT

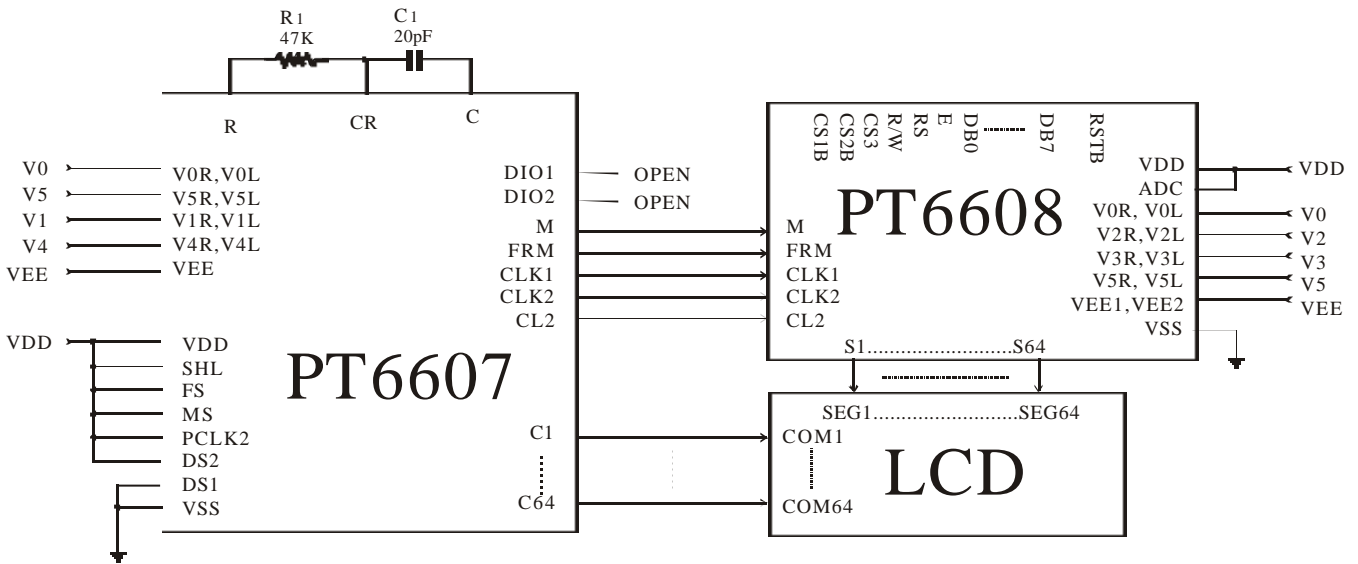

Power Driver Circuit

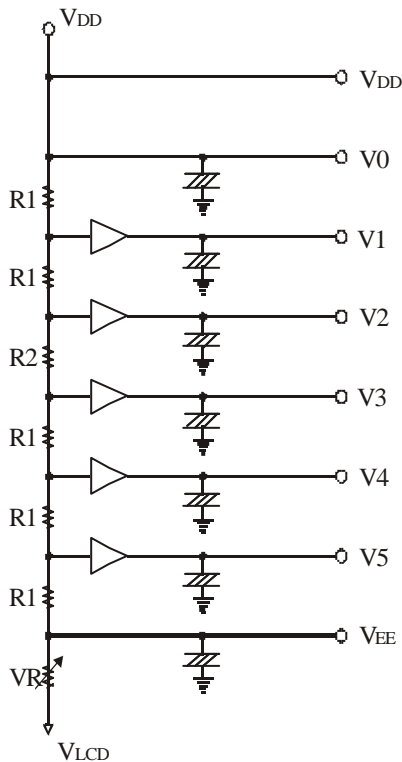

Duty	Bias	Rdiv
1/48	1/8	R2=4R1
1/64	1/9	R2=5R1
1/96	1/11	R2=7R1
1/128	1/12	R2=8R1

Note: 1. When the duty factor is 1/48, the value of R1 and R2 must satisfy the following:

$$R1/(4R1+R2)=1/8$$

$$R1=3\text{ k}$$

$$R2=12\text{ k}$$

2. Bias means division of voltage between V_{DD} and V_{EE}.
Ex. 1/8 Bias means divide the voltage V_{DD} and V_{EE} to be 8 equalizers.

3. V₁, V₂, V₃, V₄, V₅ and V_{EE} voltage levels can be adjusted by the VR.

LCD Panel Interface Application Circuit

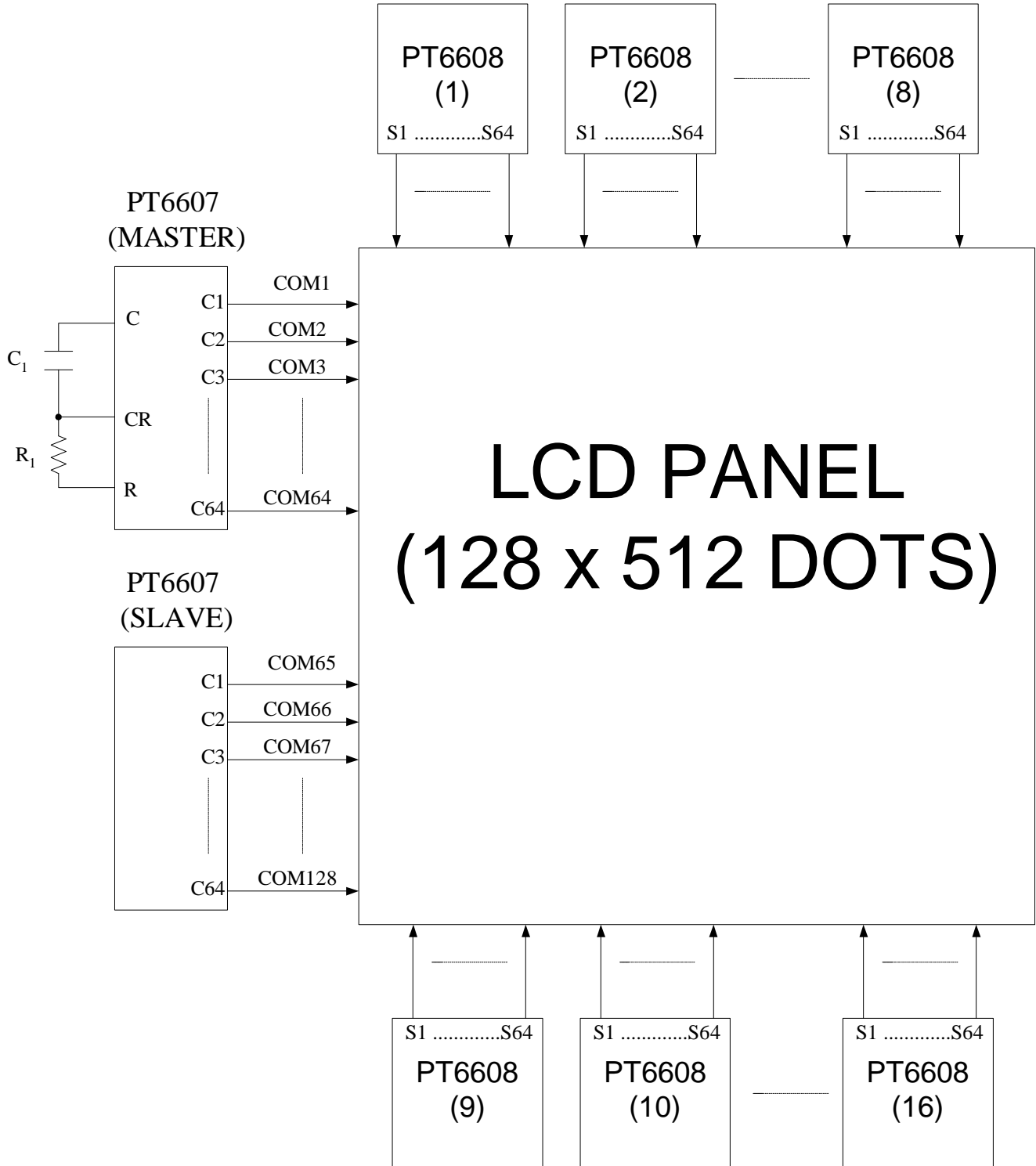



ORDER INFORMATION

Valid Part Number	Package Type
PT6607	100 Pins, QFP Package
PT6607-H	C.O.B