



Features

- Single Device: 30ADC
- +12V-Input
- High Efficiency: 92% @3.3V
- Programmable Output: (VRM Compatible 5-bit Codes)
- Multiphase Topology
- Output Remote Sense
- Over-Current Protection
- Thermal Shutdown
- Standby On/Off Control
- Space-Saving Package
- Solderable Copper Case

Description

The PT8120 Excalibur™ power modules are a family of high-output, high-efficiency, fully integrated switching regulators (ISRs), housed in a solderable 31-pin space-saving copper package. These modules operate from a nominal input voltage of +12V to provide up to 30A of output current at output voltages as low as 0.8V. The output voltage is programmable via a 5-bit input code.

The PT8120 family incorporates a state-of-the-art, 2-phase, multiple power path topology. This extends the output current range while providing superior transient response and input current ripple performance.

The PT8120 family is designed to power high-end computing and signal processing applications, all of which demand high output currents at low supply voltages.

The modules have a number of features to facilitate system integration. These include over-current protection, thermal shutdown, an on/off standby control, and an output remote sense to compensate for voltage drop between the regulator and the load. In addition, the voltage programming codes for the PT8121, PT8122, & PT8124 are compatible with Intel's® VRM specifications.

Ordering Information

PT8121	= 1.3V to 3.5V
PT8122	= 1.075V to 1.85V
PT8123	= 0.8V to 1.575V
PT8124	= 1.05V to 1.825V
PT8125	= 4.5V to 7.6V

PT Series Suffix (PT1234x)

Case/Pin Configuration	Order Suffix	Package Code
Vertical	N	(EKH)
Horizontal	A	(EKF)
SMD	C	(EKG)

(Reference the applicable package code drawing for the dimensions and PC board layout)

PT812x Standard Application (See page 4 for PT8124 application schematic)

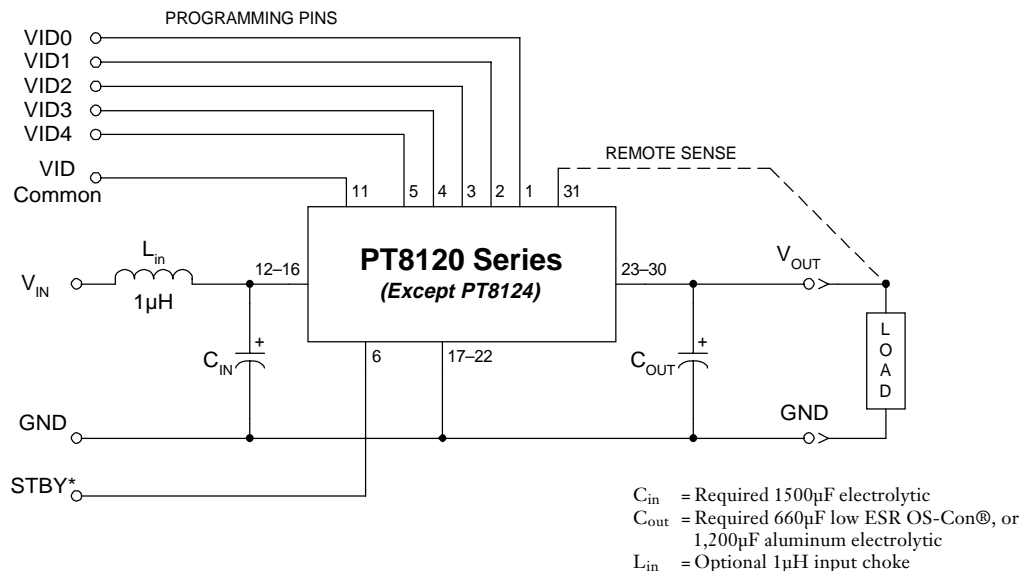

PT8120 Series

30-A 12-V Input Programmable Integrated Switching Regulator

Pin-Out Information (Except PT8124 †)

Pin	Function	Pin	Function	Pin	Function
1	VID 0	12	V _{in}	22	GND
2	VID 1	13	V _{in}	23	V _{out}
3	VID 2	14	V _{in}	24	V _{out}
4	VID 3	15	V _{in}	25	V _{out}
5	VID 4	16	V _{in}	26	V _{out}
6	STBY*	17	GND	27	V _{out}
7	Do Not Connect	18	GND	28	V _{out}
8	Do Not Connect	19	GND	29	V _{out}
9	Do Not Connect	20	GND	30	V _{out}
10	Do Not Connect	21	GND	31	Remote Sense
11	VID Common				

* For STBY pin:
 Open = Output Enabled
 Ground = Output Disabled

† See page 4 for PT8124 pin-out

Output Voltage Programming Information (Except PT8124)

VID 3	VID 2	VID 1	VID 0	PT8121 (VRM 8.3/8.4)		PT8122 (VRM 9.0)		PT8123 (Custom Code)		PT8125 (Custom Code)	
				VID 4=1 Vout	VID 4=0 Vout	VID 4=1 Vout	VID 4=0 Vout	VID 4=1 Vout	VID 4=0 Vout	VID 4=1 Vout	VID 4=0 Vout
1	1	1	1	2.00V	1.30V	1.075V	1.475V	0.800V	1.200V	4.5V	6.1V
1	1	1	0	2.10V	1.35V	1.100V	1.500V	0.825V	1.225V	4.6V	6.2V
1	1	0	1	2.20V	1.40V	1.125V	1.525V	0.850V	1.250V	4.7V	6.3V
1	1	0	0	2.30V	1.45V	1.150V	1.550V	0.875V	1.275V	4.8V	6.4V
1	0	1	1	2.40V	1.50V	1.175V	1.575V	0.900V	1.300V	4.9V	6.5V
1	0	1	0	2.50V	1.55V	1.200V	1.600V	0.925V	1.325V	5.0V	6.6V
1	0	0	1	2.60V	1.60V	1.225V	1.625V	0.950V	1.350V	5.1V	6.7V
1	0	0	0	2.70V	1.65V	1.250V	1.650V	0.975V	1.375V	5.2V	6.8V
0	1	1	1	2.80V	1.70V	1.275V	1.675V	1.000V	1.400V	5.3V	6.9V
0	1	1	0	2.90V	1.75V	1.300V	1.700V	1.025V	1.425V	5.4V	7.0V
0	1	0	1	3.00V	1.80V	1.325V	1.725V	1.050V	1.450V	5.5V	7.1V
0	1	0	0	3.10V	1.85V	1.350V	1.750V	1.075V	1.475V	5.6V	7.2V
0	0	1	1	3.20V	1.90V	1.375V	1.775V	1.100V	1.500V	5.7V	7.3V
0	0	1	0	3.30V	1.95V	1.400V	1.800V	1.125V	1.525V	5.8V	7.4V
0	0	0	1	3.40V	2.00V	1.425V	1.825V	1.150V	1.550V	5.9V	7.5V
0	0	0	0	3.50V	2.05V	1.450V	1.850V	1.175V	1.575V	6.0V	7.6V

Notes:

- i) Logic 0 = Connect to VID Common
- ii) Logic 1 = Open circuit (no pull-up resistors)
- iii) VID3 and VID4 may not be changed while the unit is operating.
- iv) See page 4 for PT8124 (VRM 8.5) programming information.

PT8121 / 2 / 3 / 5 Specifications (Unless otherwise stated $T_a = 25^\circ\text{C}$, $C_{in} = 1,500\mu\text{F}$, $C_{out} = 660\mu\text{F}$, $V_{in} = 12\text{V}$, & $I_o = I_{o,max}$)

Characteristics	Symbols	Conditions	PT8121 / 2 / 3 / 5 Only				Units
			Min	Typ	Max		
Output Current	I_o	Natural convection or 60°C with 200LFM airflow	$V_o \leq 3.5\text{V}$	0.1 (1)	—	30	A
			$V_o \geq 4.5\text{V}$	0.1 (1)	—	28	
Input Voltage Range	V_{in}	Over I_o Range	10.8	—	13.2	V	
Set-Point Voltage Tolerance	V_o tol	Over V_o range	—	± 1	± 2	%V	
Line Regulation	ΔReg_{line}	Over V_{in} range	—	± 10	—	mV	
Load Regulation	ΔReg_{load}	Over I_o range	—	± 10	—	mV	
Temperature Variation	ΔReg_{temp}	$-40^\circ\text{C} \leq T_a \leq 85^\circ\text{C}$	—	± 0.5	—	% V_o	
Total Output Voltage Variation	$\Delta V_{o,tot}$	Includes set-point, line load, $-40^\circ\text{C} \leq T_a \leq 85^\circ\text{C}$	—	—	± 3	%V	
Efficiency	η	$I_o = 15\text{A}$	$V_o = 5.0\text{V}$	—	94	—	%
			$V_o = 3.3\text{V}$	—	92	—	
			$V_o = 2.5\text{V}$	—	90	—	
			$V_o = 1.8\text{V}$	—	86	—	
			$V_o = 1.5\text{V}$	—	84	—	
			$V_o = 1.2\text{V}$	—	81	—	
		$I_o = I_{o,max}$	$V_o = 5.0\text{V}$	—	93	—	%
			$V_o = 3.3\text{V}$	—	91	—	
			$V_o = 2.5\text{V}$	—	88	—	
			$V_o = 1.8\text{V}$	—	84	—	
			$V_o = 1.5\text{V}$	—	82	—	
			$V_o = 1.2\text{V}$	—	78	—	
V_o Ripple (pk-pk)	V_r	20MHz bandwidth	—	20	—	mV	
Transient Response	t_{tr}	1A/ μs load step, 50% to 100% $I_{o,max}$	—	50	—	μSec	
		V_o over/undershoot	—	100	—	mV	
Over-Current Threshold	I_{TRIP}	Reset followed by auto-recovery	$V_o \geq 4.5\text{V}$	—	40	—	A
			$V_o \leq 3.5\text{V}$	—	45	—	
Switching Frequency	f_s	Over load range	300	350	400	kHz	
Standby Control (pin 6)	V_{IH} V_{IL} I_{IL}	Referenced to GND (pins 17–22) Pin 6 to GND	—	—	Open (2)	V	
			-0.2	—	0.8		
			—	0.5	—		mA
Standby Input Current	$I_{in, standby}$	Pin 6 to GND	—	35	—	mA	
External Output Capacitance	C_{out}	See PT812x application schematic	660 (3)	—	30,000	μF	
External Input Capacitance	C_{in}	See PT812x application schematic	1,500	—	—	μF	
Operating Temperature Range	T_a	Over V_{in} Range	-40 (4)	—	+85 (5)	$^\circ\text{C}$	
Storage Temperature	T_s	—	-40	—	+125	$^\circ\text{C}$	
Mechanical Shock	—	Per Mil-STD-883D, Method 2002.3 1 msec, Half Sine, mounted to a fixture	—	500	—	G's	
Mechanical Vibration	—	Mil-STD-883D, Method 2007.2 20-2000 Hz, soldered in PCB	—	20 (6)	—	G's	
Weight	—	Vertical/Horizontal	—	55	—	grams	
Flammability	—	Materials meet UL 94V-0	—	—	—	—	

Notes: (1) ISR will operate down to no load with reduced specifications.

(2) The Standby input (pin 6) has an internal pull-up. If it is left open-circuit the PT812x will operate when input power is applied. A low-leakage MOSFET is recommended to control this input. The open-circuit voltage is nominally 5V. See application notes for interface considerations.

(3) The PT8120 regulators require a minimum of 660 μF , low ESR output capacitance (1,200 μF for standard aluminum electrolytic) for proper operation.

(4) For operation below 0°C, C_{out} must have stable characteristics. Use either low ESR tantalum or Oscon® capacitors.

(5) See safe Operating Area curves or consult factory for the appropriate derating.

(6) The case pins on the through-hole package types (suffixes N & A) must be soldered. For more information see the applicable package outline drawing.

Input Filter: An input filter inductor is optional for most applications. The inductor must be rated to handle the projected input current. A rating of 10ADC for $V_{out} \leq 3.3\text{V}$, and 15ADC for $V_{out} \geq 4.5\text{V}$ is recommended. The input capacitance must be rated for a minimum of 1.6Arms of ripple current. For transient or dynamic load applications, additional capacitance may be required. For more information consult the application note on capacitor selection.

PT8120 Series

30-A 12-V Input Programmable
Integrated Switching Regulator

PT8124 Pin-Out Information

Pin	Function	Pin	Function
1	VID 25mV	17	GND
2	VID 0	18	GND
3	VID 1	19	GND
4	VID 2	20	GND
5	VID 3	21	GND
6	STBY	22	GND
7	Do Not Connect	23	V _{out}
8	Do Not Connect	24	V _{out}
9	Do Not Connect	25	V _{out}
10	Do Not Connect	26	V _{out}
11	VID Common	27	V _{out}
12	V _{in}	28	V _{out}
13	V _{in}	29	V _{out}
14	V _{in}	30	V _{out}
15	V _{in}	31	Remote Sense
16	V _{in}		

* For STBY pin:
Open = Output Enabled
Ground = Output Disabled

PT8124 Voltage Programming Information

				(VRM 8.5)	
VID 3	VID 2	VID 1	VID 0	VID 25mV=0 V _{out}	VID 25mV=1 V _{out}
1	1	1	1	1.300V	1.325V
1	1	1	0	1.350V	1.375V
1	1	0	1	1.400V	1.425V
1	1	0	0	1.450V	1.475V
1	0	1	1	1.500V	1.525V
1	0	1	0	1.550V	1.575V
1	0	0	1	1.600V	1.625V
1	0	0	0	1.650V	1.675V
0	1	1	1	1.700V	1.725V
0	1	1	0	1.750V	1.775V
0	1	0	1	1.800V	1.825V
0	1	0	0	1.050V	1.075V
0	0	1	1	1.100V	1.125V
0	0	1	0	1.150V	1.175V
0	0	0	1	1.200V	1.225V
0	0	0	0	1.250V	1.275V

Notes:

- Logic 0 = Connect to VID Common
- Logic 1 = Open circuit (no pull-up resistors)
- VID2 and VID3 may not be changed while the unit is operating.

PT8124 Standard Application

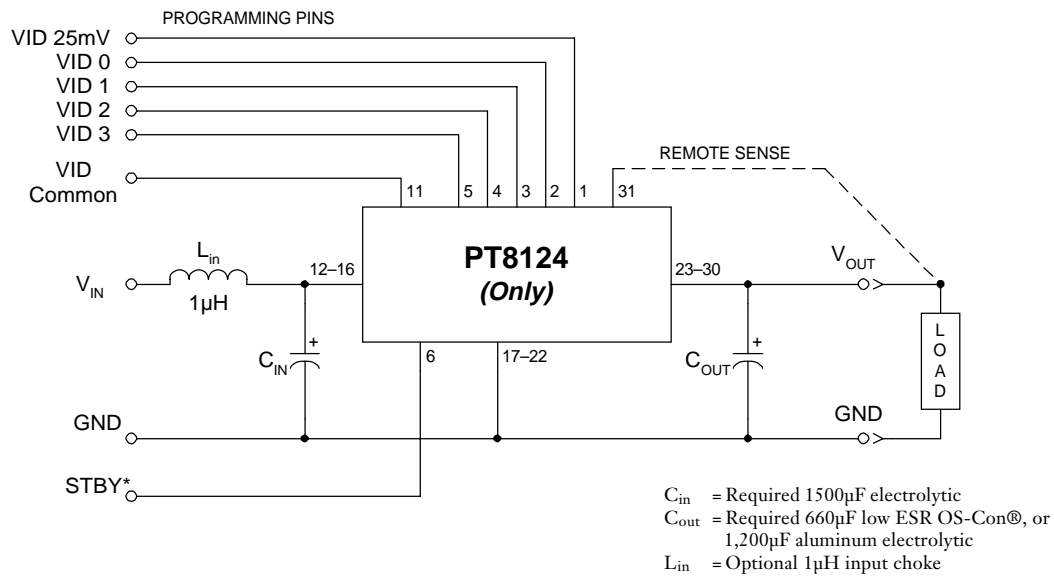

PT8124 Specifications (Unless otherwise stated $T_a = 25^\circ\text{C}$, $C_{in} = 1,500\mu\text{F}$, $C_{out} = 660\mu\text{F}$, $V_{in} = 12\text{V}$, & $I_o = I_{o,max}$)

Characteristics	Symbols	Conditions	PT8124 Only			Units	
			Min	Typ	Max		
Output Current	I_o	Natural convection or 60°C with 200LFM airflow	0.1 (1)	—	30	A	
Input Voltage Range	V_{in}	Over I_o Range	10.8	—	13.2	V	
Set-Point Voltage Tolerance	V_o, tol	Over V_o range, $I_o = 0.5\text{A}$	—	± 1	± 2	%V	
Line Regulation	$\Delta\text{Reg}_{\text{line}}$	Over V_{in} range	—	± 10	—	mV	
Load Regulation (Droop)	$\Delta\text{Reg}_{\text{load}}$	Over I_o range	—	2	—	mV/A	
Temperature Variation	$\Delta\text{Reg}_{\text{temp}}$	$-40^\circ\text{C} \leq T_a \leq 85^\circ\text{C}$, $I_o = 0.5\text{A}$	—	± 0.5	—	% V_o	
Total Output Voltage Variation	$\Delta V_{o, \text{tot}}$	Includes set-point, line, load $-40^\circ\text{C} \leq T_a \leq 85^\circ\text{C}$	—	—	85 (2)	mV	
Efficiency	η	$I_o = 15\text{A}$	$V_o = 1.8\text{V}$	—	86	—	%
			$V_o = 1.5\text{V}$	—	84	—	
			$V_o = 1.2\text{V}$	—	81	—	
		$I_o = I_{o,max}$	$V_o = 1.8\text{V}$	—	84	—	%
$V_o = 1.5\text{V}$	—	82	—				
$V_o = 1.2\text{V}$	—	78	—				
V_o Ripple (pk-pk)	V_r	20MHz bandwidth	—	20	—	mV	
Transient Response	t_{tr}	1A/ μs load step, 50% to 100% $I_{o,max}$	—	50	—	μSec	
	ΔV_{tr}	V_o over/undershoot	—	50	—	mV	
Over-Current Threshold	I_{TRIP}	Reset followed by auto-recovery	—	47	—	A	
Switching Frequency	f_s	Over load range	300	350	400	kHz	
Standby Control (pin 6)		Referenced to GND (pins 17–22)					
Input High Voltage	V_{IH}		—	—	Open (3)	V	
Input Low Voltage	V_{IL}		-0.2	—	0.8		
Input Low Current	I_{IL}	Pin 6 to GND	—	0.5	—	mA	
Standby Input Current	$I_{in, \text{standby}}$	Pin 6 to GND	—	35	—	mA	
External Output Capacitance	C_{out}	See PT8124 application schematic	660 (4)	—	30,000	μF	
External Input Capacitance	C_{in}	See PT8124 application schematic	1,500	—	—	μF	
Operating Temperature Range	T_a	Over V_{in} Range	-40 (5)	—	+85 (6)	$^\circ\text{C}$	
Storage Temperature	T_s	—	-40	—	+125	$^\circ\text{C}$	
Mechanical Shock		Per Mil-STD-883D, Method 2002.3 1 msec, Half Sine, mounted to a fixture	—	500	—	G's	
Mechanical Vibration		Mil-STD-883D, Method 2007.2 20-2000 Hz, soldered in PCB	—	20 (7)	—	G's	
Weight	—	Vertical/Horizontal	—	55	—	grams	
Flammability	—	Materials meet UL 94V-0	—	—	—	—	

Notes: (1) ISR-will operate down to no load with reduced specifications.

(2) Total output voltage variation includes load regulation droop, which is required for compliance with specification V_{RM} 8.5-4

(3) The Standby input (pin 6) has an internal pull-up. If it is left open-circuit the PT812x will operate when input power is applied. A low-leakage MOSFET is recommended to control this input. The open-circuit voltage is nominally 5V. See application notes for interface considerations.

(4) The PT8120 regulators require a minimum of 660 μF low ESR output capacitance (1,200 μF for standard aluminum electrolytic) for proper operation.

(5) For operation below 0 $^\circ\text{C}$, C_{out} must have stable characteristics. Use either low ESR tantalum or Oscon[®] capacitors.

(6) See safe Operating Area curves or consult factory for the appropriate derating.

(7) The case pins on the through-hole package types (suffixes N & A) must be soldered. For more information see the applicable package outline drawing.

Input Filter: An input filter inductor is optional for most applications. The inductor must be rated to handle the projected input current. A rating of 10ADC for $V_{out} \leq 3.3\text{V}$, and 15ADC for $V_{out} \geq 4.5\text{V}$ is recommended. The input capacitance must be rated for a minimum of 1.6Arms of ripple current. For transient or dynamic load applications, additional capacitance may be required. For more information consult the application note on capacitor selection.

PT8120 Series

30-A 12-V Input Programmable
Integrated Switching Regulator

Characteristic Data; $V_{in} = 12V$ (See Note A)

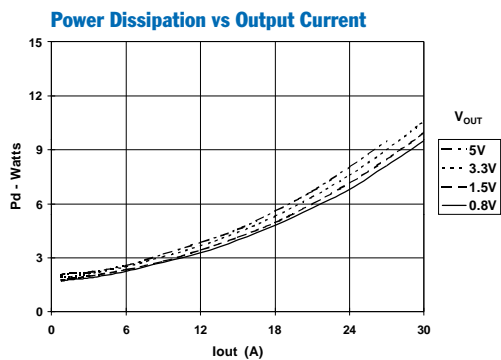
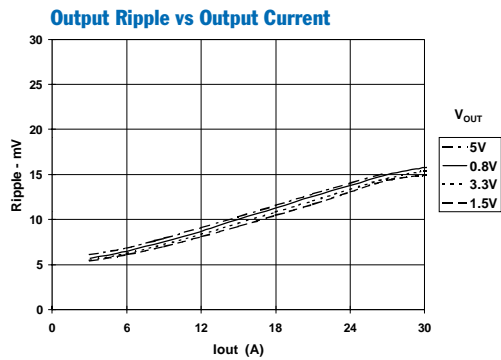
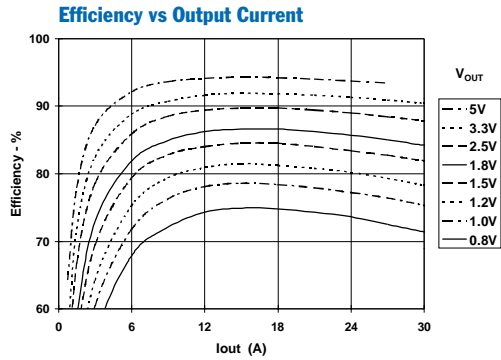

Safe Operating Area; $V_{in} = 12V$ (See Note B)

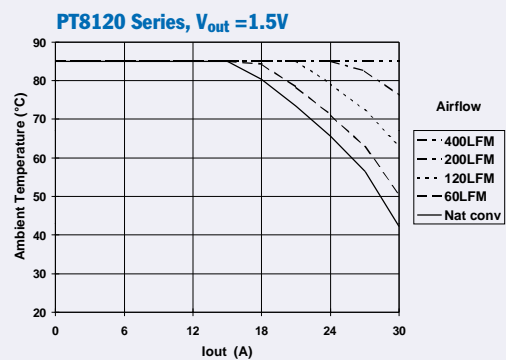
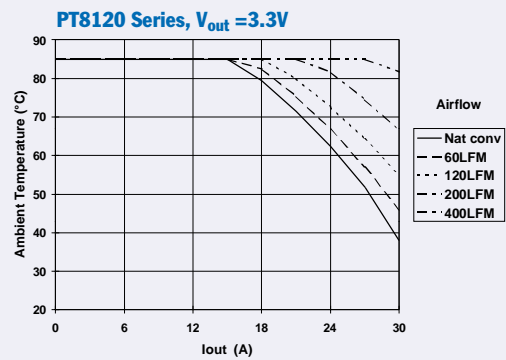
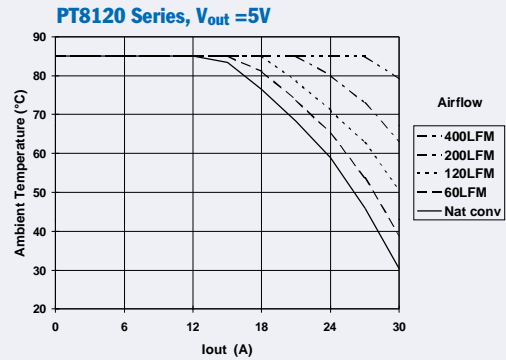

Note A: Characteristic data has been developed from actual products tested at 25°C. This data is considered typical data for the Converter.

Note B: SOA curves represent the conditions at which internal components are at or below the manufacturer's maximum operating temperatures

Capacitor Recommendations for the PT8120 Series of Programmable ISRs

Input Capacitors

The recommended input capacitor(s) is determined by 1.6 Arms minimum ripple current rating and 1,500µF minimum capacitance. Ripple current and Equivalent Series Resistance (ESR) values are the major considerations along with temperature when selecting the proper capacitor. The tantalum capacitors listed below cannot be used on the input bus since they are not rated for 12V operation.

Output Capacitors

The minimum required output capacitance is 660µF (organic/polymer), or 1,200 (aluminum electrolytic) with a maximum ESR less than or equal to 50mΩ. Failure to observe this requirement may lead to regulator instability or oscillation. Electrolytic capacitors have poor ripple performance at frequencies greater than 400kHz, but excellent low frequency transient response. Above the ripple frequency ceramic decoupling capacitors are necessary to improve the transient response and reduce any microprocessor high frequency noise components apparent during higher current excursions. Preferred low ESR type capacitor part numbers are identified in the Table 1 below.

Tantalum Characteristics

Tantalum capacitors are recommended on the output bus but only AVX TPS Series, Sprague 593D/594/595 Series, or Kemet T495/T510,520 Series. These capacitors are recommended over other types due to their higher surge current, excellent power dissipation and ripple current ratings. As a caution, the TAJ Series by AVX is not recommended. This series exhibits considerably higher ESR, reduced power dissipation and lower ripple current capability. The TAJ Series is also less reliable compared to the TPS series when determining power dissipation capability.

Capacitor Table

Table 1 identifies the characteristics of capacitors from a number of vendors with acceptable ESR and ripple current (rms) ratings. The suggested minimum quantities per regulator for both the input and output buses are identified.

This is not an extensive capacitor list. Capacitors from other vendors are available with comparable specifications. Those listed are for guidance. The RMS ripple current rating and ESR (Equivalent Series Resistance at 100kHz) are the critical parameters are necessary to insure both optimum regulator performance and long capacitor life.

Table 1 Capacitors Characteristic Data

Capacitor Vendor/ Series	Capacitor Characteristics					Quantity		Vendor Part Number
	Working Voltage	Value(µF)	(ESR) Equivalent Series Resistance	105°C Maximum Ripple Current(Irms)	Physical Size(mm)	Input Bus	Output Bus	
Panasonic FC (Radial) FC/FK (Surface Mount)	35V	1500	0.028Ω	2490mA	18× 20	1	1	EEUFC1V152S
	25V	1500	0.029Ω	2205mA	16× 20	1	1	EEUFC1E152S
	16V	4700	0.033Ω	2060mA	18×16.5	1	1	EEVFK1C472M
	25V	2200	0.028Ω	2490mA	18×21.5	1	1	EEVFC1E222N
	16V	2200	0.038Ω	2000mA	18×16.5	2	1	EEVFC1C222N
United Chemi-con LXZ Series	35V	1800	0.028Ω	2490mA	18× 20	1	1	LXZ35VB182M18X20LL
	25V	1800	0.029Ω	2210mA	16×20	1	1	LXZ25VB182M16X20LL
	16V	2700	0.029Ω	2210mA	16× 20	1	1	LXZ16VB272M16X20LL
Nichicon PW Series PM Series	25V	1000	0.038+2Ω	3200mA	12.5×20	2	1	UPW1E102MHH
	25V	1800	0.029Ω	2205mA	16×20	1	1	UPW1E182MHH6
	25V	1500	0.034Ω	1770mA	16×20	1	1	UPM1E152MHH6
Os-con:(Organic) SS SV (Surface Mount)	10V	330	0.025Ω	3500mA	10×10.5	N/R(1)	2	10SS330M (V _o <6V)
	10V	330	0.020Ω	3800mA	10.3×10.3	N/R(1)	2	10SV330 (V _o <6V)
AVX Tantalum TPS (Surface Mount)	10V	330	0.1Ω±2 =0.05Ω	>2500mA	7.3L	N/R(1)	2	TPSE337M010R0100 (V _o <5V)
	10V	330	0.06Ω±2 =0.03Ω	>3000mA	×5.7W ×4.1H	N/R(1)	2	TPSV337M010R0060 (V _o <5V)
Kemet Polymer/Tantalum T520Series (Surface Mount)	10V	330	0.040+2Ω	1800mA	4.3W	N/R(1)	2	T520X337M010AS (V _o <6V)
	10V	330	0.040+2Ω	>1800mA	×7.3L ×4.0H	N/R(1)	2	T520D330M006AS (V _o <4V)
Sprague Tantalum 594D Series (Surface Mount)	10V	330	0.045+2Ω	2360mA	7.2L ×6W ×4.1H	N/R(1)	2	594D337X0010R2T(V _o <5V)

Note: (N/R -Not recommended) The 10V-rated tantalum capacitors cannot be used on the input bus.

Using the On/Off Standby Function of the PT8120 Series of Programmable ISRs

The PT8120 series of programmable ISRs incorporates an On/Off Standby function. This feature may be used to turn the regulated output of the module off while input voltage is applied. This places the module in “standby” mode. The standby control may be used for power-up sequencing, or wherever there is a requirement to control the module’s output status from another circuit.

The Standby function is provided by the *STBY** control, pin 6. If pin 6 is left open-circuit the regulator operates normally, providing a regulated output when a valid supply voltage is applied to V_{in} (pins 10-16) with respect to GND (pins 17-22). Connecting pin 6 to ground¹ places the regulator in standby mode², and reduces the input current to typically 35mA. Applying a ground signal to pin 6 prior to power-up, will inhibit the output during the period that input power is applied. When the ground signal to pin 6 is removed, the regulator initiates a soft-start to re-establish the set output voltage.³ To ensure that the regulator output is properly enabled, the *STBY** control pin must be open circuit.

1. In the standby mode the output of the regulator is tri-state, and the output voltage falls at the rate that the load circuit discharges the output filter capacitors.
2. In the standby mode the output of the regulator is tri-state, and the output voltage falls at the rate that the load circuit discharges the output filter capacitors.
3. When the ground signal to the *Standby* pin is removed, the regulator output initiates a soft-start cycle by first asserting a low impedance to ground. If an external voltage is applied to the output bus, it will sink current and possibly over-stress the part.

Turn-On Time

Turning Q_1 in Figure 1 off, removes the low-voltage signal at pin 6. After approximately 5-ms the regulator output rises and reaches full regulation within 40ms. Fig. 2 shows the typical waveforms of a PT8121 following the prompt turn-off of Q_1 . The turn-off of Q_1 corresponds to the rise in V_{stby} . The output voltage was set to 3.3V, and the waveforms were measured with a 12V input source, and 18A resistive load.

Table 1 Standby Control Requirements²

Parameter	Min	Typ	Max
V_{IH}	—	—	Open Cct. ¹
V_{IL}	-0.2V	—	0.8V
I_{STBY}	—	-0.5mA	—

Notes:

1. The standby on a PT8120 series regulators must be controlled with an open-collector (or open-drain) transistor (See fig. 1). *Do Not* use a pull-up resistor. Table 1 gives the *STBY** pin parameters. The control pin has an open-circuit voltage of 5Vdc. To shut the regulator output off, the control pin must be “pulled” to less than 0.8Vdc with a low-impedance sink to ground.

Figure 2

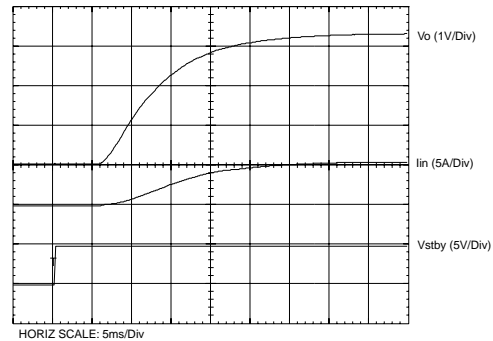
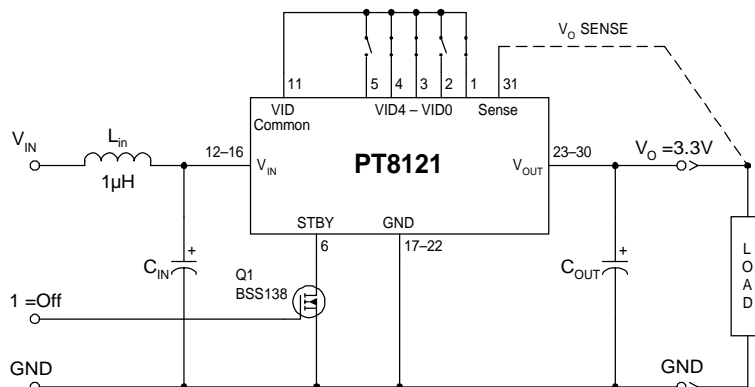

Figure 1



Pin-Coded Output Voltage Programming of the 30-A Rated PT8120 Series Regulators

The PT8120 series of Excalibur® ISRs incorporate a pin-coded output voltage control. These regulators must be programmed to a specific output voltage from a pre-set range defined by the regulator model. Programming is achieved by selectively connecting the control inputs, “VID0–VID4” (pins 1–5), to the “VID Common” (pin 11).¹ The programming code and voltage range for each model is defined in the data sheet. Refer to the PT8120 Series data sheet for more information. The program codes for the PT8121, PT8122, and PT8124 models are also compatible with some of the “Voltage ID” codes defined by Intel’s® VRM specifications. Figure 1 shows the pin-strap connections for selecting the desired output voltage from the program code range.

Notes:

- The programming convention is as follows:-
 Logic 0: Connect to pin 11 (VID Common).
 Logic 1: Open circuit/open drain (See notes 2, & 4)
- Do not connect pull-up resistors to the voltage programming pins.
- To minimize output voltage error, use pin 11 (VID Common) as the logic “0” reference. If the regulator is used to power a VRM compatible microprocessor this may not be practical. In this case connect pin 11 to pins 17–22, or the ground plane close to the regulator.

- If active devices are used to ground the voltage control pins, low-level open drain MOSFETs should be used over bipolar transistors. The inherent $V_{ce(sat)}$ in bipolar devices introduces errors in the device’s internal voltage control circuit. Discrete transistors such as the BSS138, 2N7002, IRLML2402, are examples of appropriate devices.

Active Voltage Programming:

Special precautions should be taken when making changes to the voltage control program code while the output is active. It is recommended that the ISR be powered down or held placed in standby. Changes made to the program code while V_{out} is active induces high current transients through the device. This is the result of the electrolytic output capacitors being either charged or discharged to the new output voltage set-point. The transient current can be minimized by making only incremental changes to the binary code, i.e. one LSB at a time. A minimum of 100µs settling time between each program state is also recommended. Making non-incremental changes to VID3 and VID4 with the output enabled is discouraged. The transients induced may activate the module’s over-current protection. If the program code cannot be asserted prior to power-up, pull pin 6, *STBY**, to GND during the period that the input voltage is applied. The release of pin 6 will then allow the device to initiate a soft-start power-up to the program voltage.

Figure 1

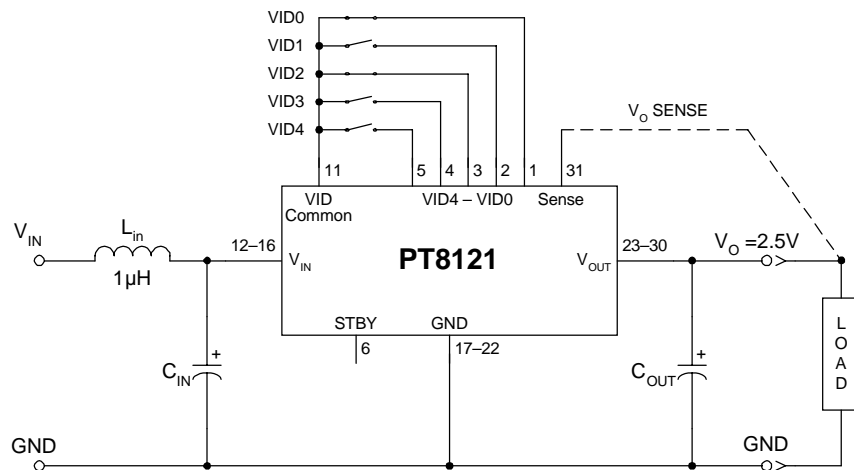

IMPORTANT NOTICE

Texas Instruments Incorporated and its subsidiaries (TI) reserve the right to make corrections, modifications, enhancements, improvements, and other changes to its products and services at any time and to discontinue any product or service without notice. Customers should obtain the latest relevant information before placing orders and should verify that such information is current and complete. All products are sold subject to TI's terms and conditions of sale supplied at the time of order acknowledgment.

TI warrants performance of its hardware products to the specifications applicable at the time of sale in accordance with TI's standard warranty. Testing and other quality control techniques are used to the extent TI deems necessary to support this warranty. Except where mandated by government requirements, testing of all parameters of each product is not necessarily performed.

TI assumes no liability for applications assistance or customer product design. Customers are responsible for their products and applications using TI components. To minimize the risks associated with customer products and applications, customers should provide adequate design and operating safeguards.

TI does not warrant or represent that any license, either express or implied, is granted under any TI patent right, copyright, mask work right, or other TI intellectual property right relating to any combination, machine, or process in which TI products or services are used. Information published by TI regarding third-party products or services does not constitute a license from TI to use such products or services or a warranty or endorsement thereof. Use of such information may require a license from a third party under the patents or other intellectual property of the third party, or a license from TI under the patents or other intellectual property of TI.

Reproduction of information in TI data books or data sheets is permissible only if reproduction is without alteration and is accompanied by all associated warranties, conditions, limitations, and notices. Reproduction of this information with alteration is an unfair and deceptive business practice. TI is not responsible or liable for such altered documentation.

Resale of TI products or services with statements different from or beyond the parameters stated by TI for that product or service voids all express and any implied warranties for the associated TI product or service and is an unfair and deceptive business practice. TI is not responsible or liable for any such statements.

Mailing Address:

Texas Instruments
Post Office Box 655303
Dallas, Texas 75265