

NPN SILICON RF POWER TRANSISTOR

DESCRIPTION:

The **ASI PT9701** is a Common Emitter Device Designed for Class A , AB and C Amplifier Applications in the 225 - 400 MHz Military Communications Band.

FEATURES INCLUDE:

- Gold Metalization
- Emitter Ballasting
- High Gain

MAXIMUM RATINGS

I_C	1.25 A
V_{CES}	45 V
P_{DISS}	14 W @ T _C = 25 °C
T_J	-55 °C to +200 °C
T_{STG}	-55 °C to +200 °C
θ_{JC}	12 °C/W

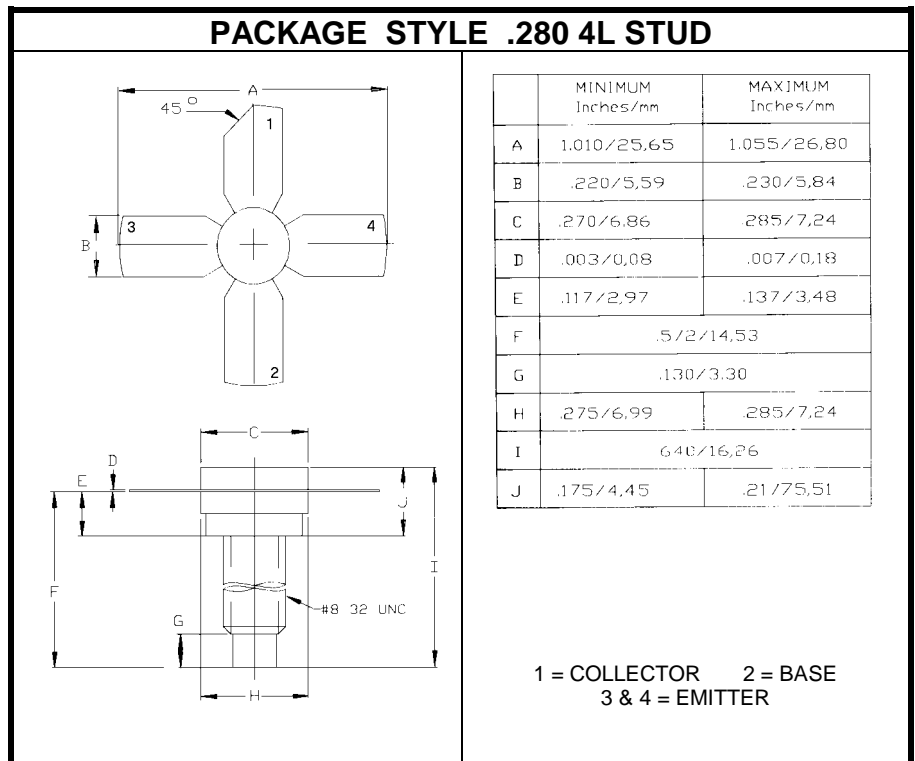
CHARACTERISTICS T_C = 25 °C

SYMBOL	TEST CONDITIONS	MINIMUM	TYPICAL	MAXIMUM	UNITS
BV_{CEO}	I _C = 20 mA	25			V
BV_{CES}	I _C = 10 mA	45			V
BV_{EBO}	I _E = 1.0 mA	3.5			V
h_{FE}	V _{CE} = 5.0 V I _C = 200 mA	15			---
C_{ob}	V _{CB} = 28 V f = 1.0 MHz			7.0	pF
P_G η_C	V _{CE} = 28 V P _{out} = 5.0 W f = 400 MHz	10 50	12 55		dB %