

AN AMERICAN NATIONAL STANDARD

Speed and Load Governing Systems for Steam Turbine - Generator Units

ANSI / ASME
PTC 20.1-1977



PERFORMANCE
TEST
CODES

THE AMERICAN SOCIETY OF MECHANICAL ENGINEERS
United Engineering Center
345 East 47th Street New York, N.Y. 10017

<https://DatasheetsPDF.com/>

**Speed and Load
Governing Systems
for Steam
Turbine-Generator
Units**

ANSI/ASME - PTC 20.1-1977

**PERFORMANCE
TEST
CODES**

No part of this document may be reproduced in any form, in an electronic retrieval system or otherwise, without the prior written permission of the publisher.

Copyright © 1977 by
THE AMERICAN SOCIETY OF MECHANICAL ENGINEERS
All Rights Reserved
Printed in U.S.A.

FOREWORD

Power Test Code Committee No. 20 on Speed-Responsive Governors was established by the ASME Power Test Codes Committee in 1921 and the Test Code for Speed-Responsive Governors as prepared by this Committee was issued in May 1927. Subsequently, since it was found that this code was inadequate, Power Test Code Committee No. 20 was reorganized in 1940 and its scope expanded to include speed, temperature and pressure responsive governors for prime movers.

In 1941 the Joint AIEE-ASME Committee on a Recommended Specification for Prime-Mover Speed Governing was formed. The fundamental studies for prime-mover speed governing were made. The fundamental studies for the preparation of the code for testing were identical with those for the preparation of the recommended specification. Close coordination of the work by both Committees to assure the successful completion of their respective assignments, was accomplished by the appointment of personnel common to both Committees.

By mutual agreement, the work of the Specification Committee took precedence over that of PTC Committee No. 20 whose labors were interrupted during World War II.

In order to facilitate the use of the code, PTC Committee No. 20 decided in 1946 to issue their assignment in several publications, and in the following sequence:

- (1) Test Code for Speed-Governing Systems for Steam Turbine-Generator Units (PTC 20.1)
- (2) Test Code for Emergency Governors for Steam Turbine-Generator Units (PTC 20.2)
- (3) Test Code for Pressure-Regulating Systems for Steam Turbine-Generator Units (PTC 20.3)

With the issuance of AIEE Publication No. 600 in May, 1949, covering "Recommended Specification for Speed-Governing of Steam Turbines Intended to Drive Electric Generators Rated 500 KW and Up" by the Joint AIEE-ASME Committee, the way was cleared to proceed with the preparation of the first code in the series.

That code was approved by the Power Test Codes Committee on September 4, 1958. It was approved and adopted by the Council on September 23, 1958.

The Committee was again reorganized and produced PTC 20.2 Overspeed Trip Systems for Steam Turbine-Generator Units, which was adopted in 1965.

In 1967, the title "Power Test Code Committee No. 20" was changed to "Performance Test Code Committee No. 20," and corresponding changes were made in the appropriate code titles.

Another change in Committee personnel and PTC 20.3 "Pressure Control Systems Used on Steam Turbine-Generator Units" was written. PTC 20.3 was adopted in 1970.

In May 1970, those Committee members remaining following the completion of PTC 20.3 were asked to begin work on an up dated revision of the 1958 edition of PTC 20.1 so that the code would recognize advances in energy control systems and associated hardware. The Committee was brought up to working strength and began work in November 1971. It was soon evident that AIEE Publication No. 600 required revision also, and the Committee recommended a joint IEEE-ASME committee be formed to revise the document. Subsequently, IEEE Committee No. 122 was formed, but because the revision work on PTC 20.1 was considerably advanced, IEEE 122 chose to await completion of the revised PTC 20.1 before revising Publication No. 600.

The Committee recognizes the organizational and technical contributions of H. Steen-Johnsen, Chief Staff Engineer (retired) Elliott Co. Div. of Carrier Corporation, Mr. Steen-Johnsen was chairman of the Committee during the beginning of the revision of PTC 20.1, and his work provided a major impetus toward the successful completion of the Committee's assigned task.

Committee personnel has changed somewhat since 1971, and the work of those members no longer active is recognized.

This Code was approved by the Performance Test Codes Committee on November 3, 1976. It was approved and adopted by the Council as a standard practice of the Society by action of the Board of Codes and Standards on December 29, 1976. This Test Code has been approved as an American National Standard by the ANSI Board of Standards Review on February 28, 1977.

PERSONNEL OF ASME PERFORMANCE TEST CODES
COMMITTEE NO. 20.1 ON SPEED AND LOAD GOVERNING
SYSTEMS FOR STEAM TURBINE-GENERATOR UNITS

Ola Aanstad, *Chairman*
J. J. M. Plante, *Vice Chairman*
C. L. Mount, *Secretary*

- Ola Aanstad, Senior Engineer, PWR-SD, Functional Analysis I, Monroeville Nuclear Center - 4, Bay 468, Westinghouse Electric Corporation, Box 355, Pittsburgh, Pennsylvania 15230
- James Adams, Manager, Application Engineering, Bailey Meter Company, 29801 Euclid Avenue, Wickliffe, Ohio 44092
- R. F. Amberger, P. E. Associate Professor, School of Applied Science, Rochester Institute of Technology, One Lomb Memorial Drive, Rochester, New York 14623
- Patrick C. Callan, Manager, Electric Hydraulic Control, Design Engineering, Large Steam Turbine Department, General Electric Company, Room 231, 285 North Avenue, Schenectady, New York 12345
- W. Bruce Coldiron, Section Head, Performance Instruments & Controls, Plant Engineering Division, American Electric Power Service Corporation, P.O. Box 487, Canton, Ohio 44701
- J. F. Conway, Senior Engineer, Pennsylvania Electric Company, 1001 Broad Street, Johnstown, Pennsylvania 15907
- J. V. Donovan, Mechanical Engineer, NEGEA Service Corporation, P.O. Box 190, Cambridge, Massachusetts 02139
- James J. Foti, Head, Steam Turbine Section, Machinery Systems Department, Naval Ship Engineering Center, U. S. Naval Base, Philadelphia Division, Philadelphia, Pennsylvania 19112
- C. L. Mount, Station Superintendent, Philadelphia Electric Company, Southwark Generating Station, 2501 South Delaware Avenue, Philadelphia, Pennsylvania 19148
- J. J. M. Plante, Assistant Manager & Engineering Manager, Stone & Webster Engineering Corporation, P.O. Box 5406, Denver, Colorado 80217
- Arthur W. Richardson, Fellow Engineer, Service Engineering, Steam Turbine Division Engineering, Westinghouse Electric Corporation, Lester Branch, P.O. Box 9175, Philadelphia Pennsylvania 19113
- George P. Schanzenbach, Project Engineer, Gilbert Associates, P.O. Box 1498, Reading, Pennsylvania 19603
- Garin M. Vandemark, Chief Mechanical Engineer, Woodward Governor Company, P.O. Box 1519, Fort Collins, Colorado 80521

Personnel of Performance Test Codes Committee

K. C. Cotton, *Chairman*
J. H. Fernandes, *Vice Chairman*

D. W. Anacki
R. P. Benedict
W. A. Grandall
R. C. Dannettel
C. A. Dewey
V. F. Estcourt
A. S. Grimes
K. G. Grothues

Robert Jorgensen
E. L. Knoedler
W. C. Krutzsch, Jr.
Paul Leung
F. H. Light
S. W. Lovejoy
W. G. McLean
J. W. Murdock

L. C. Neale
W. C. Osborne
R. J. Reyton
W. A. Pollock
J. H. Potter
C. B. Scharp
J. F. Sebald
J. C. Westcott

ASME PERFORMANCE TEST CODES

Code for

SPEED AND LOAD GOVERNING SYSTEMS FOR STEAM TURBINE-GENERATOR UNITS

CONTENTS

Section	Para.	Section	Para.
0	INTRODUCTION		
1	OBJECT AND SCOPE		
2	DEFINITIONS AND DESCRIPTION OF TERMS		
	Types of Steam Turbines	2.01	
	Speed and Load Governing System Components	2.02	
	Functions, Characteristics, and Definitions	2.03	
3	GUIDING PRINCIPLES		
	Advance Planning and Preparation for Tests	3.01	
	Items on Which Agreement Shall Be Reached	3.02	
	Equipment Inspection	3.03	
	Accuracy	3.04	
	Preliminary Test	3.05	
	Operating Conditions	3.06	
	Instruments and Records	3.07	
	Evaluation of Test Results	3.08	
4	INSTRUMENTS AND METHODS OF MEASUREMENT		
	Selection of Instruments	4.0	
	General	4.01	
	Measured Quantities	4.02	
	Pressure Measurements	4.03	
	Temperature Measurements	4.04	
	Speed and Frequency Measurements	4.05	
	Motion or Travel Measurements	4.06	
	Power Output Measurements	4.07	
	Time Measurements	4.08	
	Voltage Measurements	4.09	
	Testing General	4.10	
	Procedures		
	General	4.11	
	Determination of Adjustable Speed Functions	4.12	
	Determination of Steady-State Speed Regulation	4.13	
	Determination of Steady-State Incremental Speed Regulation	4.14	
	Determination of Dead Band	4.15	
	Determination of Steady-State Governing Speed Band	4.16	
	Determination of Steady-State Governing Load Band	4.17	
	Determination of Step Response and Settling Time	4.18	
	Determination of Overspeed	4.19	
	Determination of Speed/Load Changer Governing System Reference Reducing Time	4.20	
5	COMPUTATION OF RESULTS		
	General	5.0	
	Evaluation of Results	5.1	
	Adjustable Speed Functions	5.12	
	Steady-State Speed Regulation	5.13	
	Steady-State Incremental Speed Regulation	5.14	
	Dead Band	5.15	
	Steady-State Governing Speed Band	5.16	
	Steady-State Governing Load Band	5.17	
	Response and Settling Time	5.18	
	Overspeed	5.19	
	Speed/Load Changer Governing System Reference Reducing Time	5.20	
6	REPORT OF RESULTS		
	General	6.0	
	Test Report Form	6.1	
7	APPENDIX		
	Numerical Examples of Calculations in Section 5	7.10	
	Illustrative Diagrams, including Descriptions of MH and EH Governing Systems	7.20	
	Instrumentation Diagrams	7.30	
	Indirect Test Methods	7.40	
	Step/Ramp Transforms	7.50	

ASME PERFORMANCE TEST CODES

SECTION 0, INTRODUCTION

0.01 This Code provides standard procedures for routine, commercial and acceptance tests for determination of the performance characteristics of steam turbine-generator unit speed and load governing systems. PTC 20.1 provides:

0.01.1 Recommended format for specifications for the performance characteristics of speed and load governing systems subject to modifications by mutual agreement between the parties to the tests and

0.01.2 Standard procedures for tests to determine the performance of speed and load governing systems.

0.02 Reference is made to the following codes and standards:

ASME PTC 6 "Steam Turbines"

ASME PTC 19 "Performance Test Code Supplements on Instruments and Apparatus"

ASME PTC 20.2 "Overspeed Trip Systems for Steam Turbine-Generator Units"

ASME PTC 20.3 "Pressure Control Systems Used on Steam Turbine-Generator Units"

IEEE Standard 100-1972 "IEEE Standard Dictionary of Electrical and Electronic Terms"

0.03 The appendix to this Code includes numerical examples of various calculations.

SECTION 1, OBJECT AND SCOPE

The purposes of this Code are:

1.01 To establish test procedures for determining performance characteristics of speed and load governing systems applicable to the equipment covered under this Code. These performance characteristics include:

- (1) Adjustable Speed Functions
 - (a) Speed/Load Changer Minimum Speed Holding Level
 - (b) Other Speed Holding Levels
 - (c) Acceleration Control
 - (d) Speed/Load Changer Low Speed Limit
 - (e) Speed/Load Changer High Speed Limit
 - (f) Synchronizing Speed Range
 - (g) Maximum Speed at Rated Power
- (2) Speed-State Speed Regulation
- (3) Steady-State Incremental Speed Regulation
- (4) Dead Band
- (5) Steady-State Governing Speed Band
- (6) Steady-State Governing Load Band
- (7) Response and Settling Time

- (8) Overspeed
- (9) Speed/Load Changer Governing System Reference Reducing Time

1.02 To establish a format and procedures for describing the system performance by means of the test quantities obtained under Par. 1.01.

1.03 This Code is applicable to the testing of speed and load governing systems for steam turbine-generator units with the steam turbines classified as follows:

- (a) Straight condensing, straight noncondensing and regenerative turbines without initial and/or exhaust steam pressure control, including reheat turbines.
- (b) Straight condensing, straight noncondensing and regenerative turbines with initial and/or exhaust steam pressure control, including reheat turbines.
- (c) Automatic extraction and mixed-pressure turbines, in conjunction with PTC 20.3, Pressure Control Systems Used on Steam Turbine-Generator Units.

SPEED AND LOAD GOVERNING SYSTEMS FOR STEAM TURBINE-GENERATOR UNITS

SECTION 2, DEFINITIONS AND DESCRIPTION OF TERMS

All terms not specifically defined in Section 2 will be used as defined in IEEE Standard 100-1972.

2.01 Types of Steam Turbines

Table 2-1

Par. No.	Term	Description
2.01.1	Straight condensing turbine	All the steam enters the turbine at one pressure and all the steam leaves the turbine exhaust at a pressure below atmospheric pressure.
2.01.2	Straight noncondensing turbine	All the steam enters the turbine at one pressure and all the steam leaves the turbine exhaust at a pressure equal to or greater than atmospheric pressure.
2.01.3	Nonautomatic extraction turbine, condensing or noncondensing	Steam is extracted from one or more stages, but without means for controlling the pressures of the extracted steam.
2.01.4	Automatic extraction turbine, condensing or noncondensing	Steam is extracted from one or more stages with means for controlling the pressure of the extracted steam.
2.01.5	Automatic extraction/induction turbine, condensing or noncondensing	Steam is extracted from or inducted into one or more stages with means for controlling the pressures of the extraction and/or induction steam.
2.01.6	Mixed pressure turbine, condensing or noncondensing	Steam enters the turbine at two or more pressures in separate inlet openings with means for controlling the inlet steam pressures.
2.01.7	Reheat turbine, condensing or noncondensing	Steam enters the turbine initially at one pressure, then is extracted at a lower pressure and temperature and reheated. The steam is then readmitted to the turbine.

ASME PTC*20.1 77 ■ 0759670 0052844 0 ■

ASME PERFORMANCE TEST CODES

2.02 Speed and Load Governing System Components Table 2-2

Par. No.	Term	Description
2.02.1	Speed and load governing system	A system that controls the speed and load of a steam turbine-generator. The system typically includes governor-controlled valves, speed governor, load governor, speed control mechanism, and load control mechanism. (Refer to Fig. 2-3.)
2.02.2	Speed governor	The speed governor includes only those elements that are directly responsive to speed and speed reference, and that furnish an input signal to the control mechanism.
2.02.3	Load governor	The load governor includes only those elements that are responsive to energy output and load reference and that furnish an input signal to the control mechanism.
2.02.4	Control mechanism	The control mechanism includes all systems, devices and mechanisms between the speed and/or load governor and the governor-controlled valves.
2.02.5	Governor-controlled valves	Those valves which control the energy input to the turbine and which are normally actuated by the speed and/or load governor directly or through the medium of the control mechanism.
2.02.6	Valve position demand signal	The control signal to the governor-controlled valves resulting from speed/load governor control action. In a mechanical-hydraulic system this may be governor-controlled valve servomotor position. 100 percent valve position demand signal is defined as that value that gives rated power output, P_r , with rated operating conditions.
2.02.7	Governor-controlled valve servomotor	An amplifying and positioning device which moves the governor-controlled valves in response to the valve position demand signal.
2.02.8	Speed/load changer	A device or devices by means of which the governing system reference may be adjusted to change the speed or power output of the turbine while the turbine is in operation.
2.02.9	High speed limit (speed/load changer)	A device or input which prevents the speed/load changer governing system reference from exceeding a predetermined upper limit, which establishes the upper limit of the synchronizing speed range.
2.02.10	Low speed limit (speed/load changer)	A device or input which prevents the speed/load changer governing system reference from decreasing below a predetermined lower limit, which establishes the lower limit of the synchronizing speed range.

SPEED AND LOAD GOVERNING SYSTEMS FOR STEAM TURBINE-GENERATOR UNITS

BLOCK DIAGRAM ILLUSTRATION OF TYPICAL LARGE STEAM TURBINE-GENERATOR

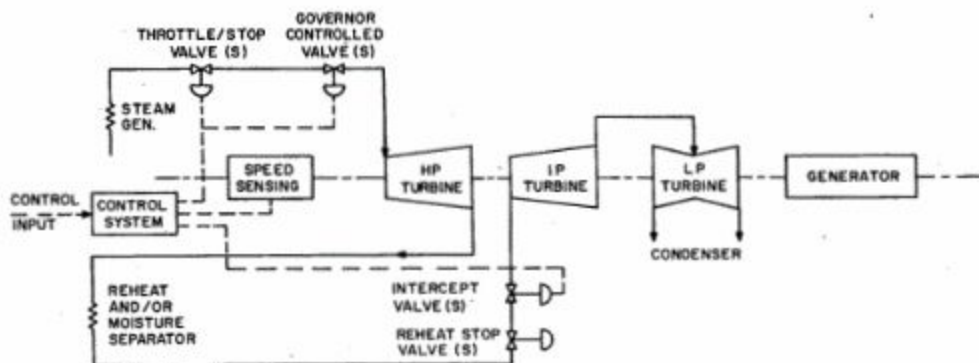

BLOCK DIAGRAM ILLUSTRATION OF TYPICAL SPEED/LOAD GOVERNING SYSTEM.

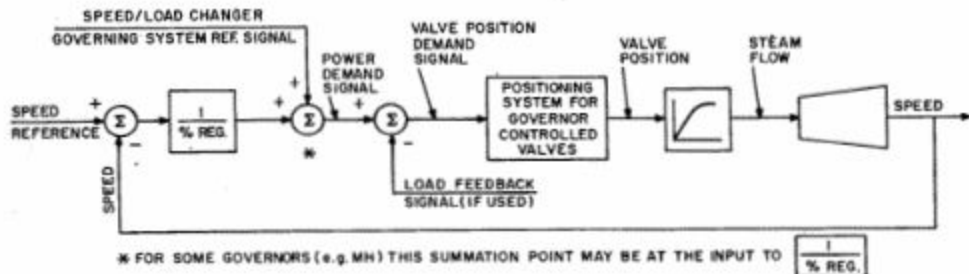

FIG. 2-3

ASME PERFORMANCE TEST CODES

Par. No.	Term	Description
2.02.11	Valve position limiter	A device which acts on the speed and load governing system to prevent the governor-controlled valves from opening beyond a preset limit. This device is sometimes known as the "load limit."
2.02.12	Steam inlet valves	Those valves which control energy input to the turbine. They may or may not be under governing system control depending on type of system and/or specific operating mode of turbine-generator at the time.
2.02.13	Throttle/stop valves	Those valves whose normal function it is to provide fast interruption of the main energy input to the turbine. These valves are sometimes used for turbine control instead of governor-controlled valves during start-up.

2.03 Functions, Characteristics and Definitions Table 2-4

Par. No.	Term	Symbol	Definition or Description	Unit
2.03.1	Dead band (speed/load governing system)	N_d	The total magnitude of the change in steady-state speed within which there is no resulting measurable change in the position of the governor-controlled valves. Dead band is the measure of the insensitivity of the speed/load governing system and is expressed in percent of rated speed.	percent
2.03.2	Factor, governor-controlled valve incremental	R_v	The rate of change of the governor-controlled valve position demand signal, in percent, with respect to the steady-state power output, in percent, at a given steady-state power and governor-controlled valve position demand signal. It is the slope of the tangent to the valve position demand signal curve at the power output point under consideration. It is a dimensionless number. (Refer to Fig. 2-7.) $R_v = \frac{\Delta D_T}{\Delta P_T} \times \frac{P_r}{D_r - D_0}$ <p>where ΔD_T = governor-controlled valve demand signal difference on the tangent.</p> <p>ΔP_T = power difference on the tangent.</p> <p>P_r = rated power output.</p> <p>D_r = governor-controlled valve position demand signal at rated power output, P_r.</p>	kW kW —

SPEED AND LOAD GOVERNING SYSTEMS FOR STEAM TURBINE-GENERATOR UNITS

Par. No.	Term	Symbol	Definition or Description	Unit
2.03.2			D_0 = governor-controlled valve position demand signal at zero power output, P_0 .	—
2.03.3	Load feedback		A signal representing power output used as input to the governing system.	
2.03.4	Load rejection		The sudden and total removal of load from the generator.	
2.03.5	Normal operating conditions		Operation of the unit at rated speed with all throttle/stop valves and shut-off valves in a fully open position with specified or agreed values of steam pressure(s), temperature(s), and with all feedwater heaters in service.	
2.03.6	Overspeed	ΔN_x	The maximum increase in speed, expressed in percent of rated speed, from rated speed following a sudden reduction of load.	percent
2.03.7	Overspeed control function		Any function that may be incorporated in the speed/load governor system that will, upon loss of load, act to limit the corresponding maximum speed rise. These functions constitute lines of defense against overspeed in addition to emergency overspeed trip systems.	
2.03.8	Power output	P	The electrical output of the turbine-generator as measured at the generator terminals.	kW
2.03.9	Power output, rated	P_r	Maximum guaranteed power output. The name-plate rating may not be the same value.	kW
2.03.10	Pressure, rated exhaust	P_{rx}	The value stated on the turbine name-plate.	in. Hg abs (mm Hg abs) psia (kPa abs)
2.03.11	Pressure, rated initial steam	P_{ri}	The value stated on the turbine name-plate.	psi (kPa)
2.03.12	Regulation, steady-state speed (for all types of turbines except automatic extraction and mixed pressure)	R_s	The change in steady-state speed expressed in percent of rated speed, when the power output of the unit is reduced from rated power output to zero power output with identical settings of all adjustments of the speed/load governing system. (Refer to Fig. 2-5.)	percent

ASME PERFORMANCE TEST CODES

Par. No.	Term	Symbol	Definition or Description	Unit
2.03.12			$R_s = \frac{N_0 - N}{N_r} \times 100$ <p> R_s = Steady-state speed regulation N_0 = Speed at zero power output N = Speed at rated power output N_r = Rated speed </p>	percent r/min r/min r/min
2.03.13	Regulation, steady-state speed (for automatic extraction and mixed-pressure turbines)	R_s	<p>The change in steady-state speed, expressed in percent of rated speed corresponding to the power output change from rated power output to zero power output with zero extraction or induction flow(s), with the pressure regulating system(s), inoperative and blocked in the position corresponding to rated extraction or induction pressure(s) at rated power output and with identical settings of all adjustments of the speed/load governing and pressure regulating system(s). It is the speed change expressed in percent of rated speed when the load is reduced from the maximum power output at which zero extraction or induction conditions are permitted to zero power output, times the ratio of rated power output to this power output change. (Refer to Fig. 2-5.)</p> $R_s = \frac{(N_0 - N_m)}{N_r} \times \frac{P_r}{P_m} \times 100$ <p> R_s = Steady-state speed regulation N_0 = Speed at zero power output N_r = Rated speed N_m = Speed at P_m P_m = Maximum power output at which zero extraction or induction conditions are permitted. P_r = Rated power output </p>	percent percent r/min r/min r/min kW kW

SPEED AND LOAD GOVERNING SYSTEMS FOR STEAM TURBINE-GENERATOR UNITS

Par. No.	Term	Symbol	Definition or Description	Unit
2.03.14	Regulation, steady-state incremental speed	R_i	<p>The rate of change of the steady state speed with respect to the power output at a given steady-state speed and power output. It is the slope of the tangent to the steady-state speed versus power output curve at the point of power output under consideration. It is expressed in percent of rated speed when the difference in steady-state speed, expressed in percent of rated speed for any two points of the tangent, is divided by the corresponding difference in power output expressed in percent of rated power output. The several points of power output at which the values of steady-state incremental speed regulation are derived are based on rated speed at each point of power output. (Refer to Figs. 2-6 and 2-7.)</p> $R_i = \frac{\Delta N_t}{\Delta P_t} \times \frac{P_r}{N_r} \times 100$ <p>where ΔN_t = speed difference on the tangent</p> <p>ΔP_t = power difference on the tangent</p> <p>P_r = rated power output</p> <p>N_r = rated speed</p>	percent
2.03.15	Regulation, governor incremental speed	R_g	<p>The rate of change of the steady-state speed with respect to the governor-controlled valve position demand signal at a given steady-state speed and governor-controlled valve position demand signal. It is the slope of the tangent to the steady-state speed versus governor-controlled valve position demand signal curve at the position demand point under consideration. It is expressed in percent of rated speed when the difference in steady-state speed, expressed in percent of rated speed, for any two points on the tangent, is divided by the corresponding difference in governor-controlled valve position demand signal, expressed in percent of the governor-controlled valve position demand signal corresponding to a change in power output from rated power output (P_r) to zero power output (P_0). The several points of valve position demand at which the values of governor incremental speed regulation are derived are based on rated speed at each governor-controlled valve position demand point. (Refer to Fig. 2-7.)</p>	percent

ASME PERFORMANCE TEST CODES

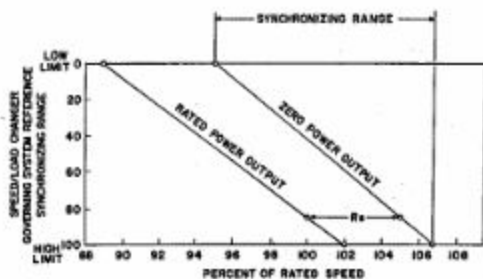

FIG. 2-5 ILLUSTRATION OF STEADY-STATE SPEED REGULATION OF 5 PERCENT

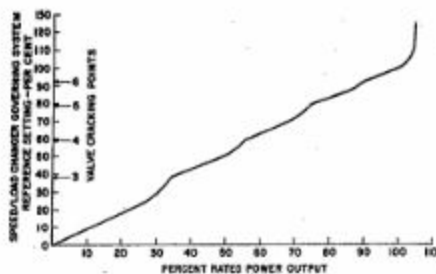

FIG. 2-6 ILLUSTRATION OF TYPICAL VALVE CURVE

VALVE POSITION DEMAND SIGNAL	R _g
30	101.3-96.9+4.4
58	103.0-97.8+5.2
80	104.5-98.9+5.6
100	106.2-100.0+6.2
114	108.0-101.0+7.0

PERCENT SPEED/LOAD CHANGER GOVERNING SYSTEM REFERENCE

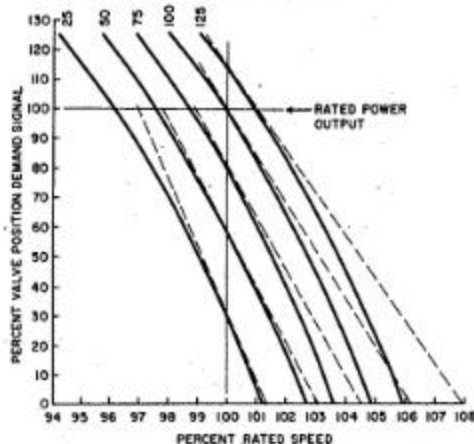

FIG. 2-7 ILLUSTRATION OF GOVERNOR INCREMENTAL SPEED REGULATION

SPEED AND LOAD GOVERNING SYSTEMS FOR STEAM TURBINE-GENERATOR UNITS

Par. No.	Term	Symbol	Definition or Description	Unit
2.03.15			$R_g = \frac{\Delta N_T}{\Delta D_T} \times \frac{D_r - D_0}{N_r} \times 100$ <p>where ΔN_T = speed difference on the tangent.</p> <p>ΔD_T = governor-controlled valve position demand signal difference on the tangent.</p> <p>D_r = governor-controlled valve position demand signal at rated power output, P_r.</p> <p>D_0 = governor-controlled valve position demand signal at zero power output, P_0.</p>	r/min — — —
2.03.16	Speed regulation is considered positive when speed increases with decrease in power output. All definitions concerning speed regulation are based on zero dead band.			
2.03.17	Speed/load changer governing system reference		An input to the governing system representing a desired speed or load.	
2.03.18	Speed/load changer governing system reference reducing time		The time required to reduce the power output from rated power output to zero power output, by operating the speed/load changer continuously at its maximum rate of change.	seconds
2.03.19	Speed/load changer governing range		The minimum steady-state speed at zero power output with the speed/load changer at the low speed limit, and the maximum steady-state speed at maximum power output with the speed/load changer at the high speed limit, both expressed in percent of rated speed.	percent
2.03.20	Speed/load changer synchronizing range		The steady-state speeds expressed in percent of rated speed corresponding to the low and high speed limit settings of the speed/load changer at zero power output.	percent
2.03.21	Speed, rated	N_r	The value stated on the unit name-plate.	r/min
2.03.22	Stability (speed/load governing system)		The capability of the speed/load governing system to position the governor-controlled valves so that a sustained oscillation of turbine speed or of power output as produced by the speed/load governing system does not exceed a specified value during operation under steady-state load demand or following a change to a new steady-state load demand.	

ASME PERFORMANCE TEST CODES

Par. No.	Term	Symbol	Definition or Description	Unit
2.03.23	Steady-state		The state of a variable where its average value exhibits only negligible change over an arbitrarily long interval of time.	
2.03.24	Steady-state governing load band	ΔP_B	The peak-to-peak magnitude of sustained oscillation of load expressed in percent of rated power output that can be attributed to the speed/load governing system only when the generator is operating in parallel with other generators and under steady-state load demand.	percent
2.03.25	Steady-state governing speed band	ΔN_B	The peak-to-peak magnitude of sustained oscillation of turbine speed expressed in percent of rated speed at rated speed that can be attributed to the speed/load governing system only, when unit is operating isolated under steady-state load demand.	percent
2.03.26	Temperature, rated initial steam	t_{ri}	The value stated on the turbine name-plate.	$^{\circ}\text{F}$ ($^{\circ}\text{C}$)
2.03.27	Time, response		The time required for the output to reach 95 percent of the change in steady-state value following a step input change.	seconds
2.03.28	Time, settling		The time required for the output to enter and remain within the band of steady state oscillations following a step input change.	seconds

SPEED AND LOAD GOVERNING SYSTEMS FOR STEAM TURBINE-GENERATOR UNITS

SECTION 3, GUIDING PRINCIPLES

3.01 Advance Planning and Preparation for Tests

3.01.1 While acceptance tests performed under the rules of this Code are voluntary at any time they should usually be undertaken shortly after the turbine-generator unit is first accepted for service, provided no serious operating difficulty exists. When tests are required by specifications as a condition of acceptance, the acceptance tests shall take place within the warranty period specified in the contract.

3.01.2 The test agenda and the procedure shall be agreed upon in advance by the parties to the tests and shall be confirmed in writing.

- (a) Test procedures shall include specific information describing the manner in which the unit will be operated and the provisions made for transfer of load in order to implement the test requirements of this Code.
- (b) Dimensions, data, drawings and diagrams of the system and components which are required for calculation purposes shall be included in the test procedures. These will include the conditions of any equipment or accessories affiliated with the unit and its speed/load governing system which might influence performance when the tests are made.

3.01.3 Test report forms and data acquisition forms shall be prepared in advance and shall conform to Section 6 "Report of Results."

3.02 Items on Which Agreement Shall Be Reached

3.02.1 Definite agreement shall be reached as to the specific tests to be performed, enumerating the system characteristics and responses that are to be tested in accordance with Par. 1.01. Specified performance of the system shall be part of such an agreement.

3.02.2 The following is a list of items upon which agreement shall be reached. Any exclusions or additions to this list must be agreed upon by the parties to the tests prior to the tests.

- (a) Object of tests and methods of operation.
- (b) The intent of the specifications and guarantees.
- (c) Means for maintaining test conditions and adjusting loads as required.
- (d) Method of operating the steam supply system and any auxiliary equipment, the performance of which may influence the test results.
- (e) Conditions that will be permissible with respect to safety of the unit such as:
 - (1) Permissible acceleration rate.

- (2) Maximum speed.
- (3) Adverse vibrations.
- (4) Effect upon steam supply system and station auxiliaries such as condensers, extraction heaters, pumps and other equipment.
- (f) Duration of operation under test conditions before test readings are started and the operating range of test runs.
- (g) Nature and limits of transients, such as maximum rates of change in metal temperatures.
- (h) Organization and number of observers and arrangements for their direction, recording of readings and calculating results.
- (i) Procedures for calibration of instruments.
- (j) Test agenda, including definite values of test loads and rotating speeds of the unit at which each individual test is to be conducted.
- (k) Apportionment of costs of tests and allocation of responsibility including personnel.
- (l) Frequency of observations and number of repeats to insure a representative sampling.

3.02.3 The following control features constitute a partial list of functions available on some governors. These control features have not been defined in Section 2 and are beyond the scope of this Code. However, if any of these functions are to be tested during the tests described elsewhere in this Code, the test requirements to demonstrate satisfactory performance of these control features shall be agreed upon prior to the tests and included in the formal agenda and procedures of the tests.

- (a) Turbine runback.
- (b) Power/load unbalance.
- (c) Trip anticipation.
- (d) Fast valving.
- (e) Load frequency control.
- (f) Overspeed control.
- (g) Initial pressure regulator.
- (h) Admission mode transfer.
- (i) Stage pressure/megawatt feedback.
- (j) Automatic turbine start.
- (k) Turbine bypass system(s).
- (l) Valve testing system(s).
- (m) Speed matching on cross compound units.

3.02.4 Personnel shall include a sufficient number of competent observers to take and record the various readings. No observer shall be required to take so many readings that lack of time may result in insufficient care and precision.

ASME PERFORMANCE TEST CODES

3.02.5 The parties to the tests shall be accorded the right to run checks on the control system during or before initial operation of the turbine.

3.02.6 Parties to the tests may agree to changes in test conditions while a test is in progress. All such special agreements shall be made in writing and included in the report of the tests.

3.02.7 No corrections or changes in settings of the speed/load governing system shall be permitted during the tests except as agreed upon in writing. No adjustments may be made to the equipment that may affect continuous and reliable operation at all capacities or outputs and under all specified operating conditions.

3.03 Equipment Inspection

3.03.1 Careful inspection and checks shall be made before, during and after the tests to insure that the turbine-generator unit is operating properly.

3.03.2 The speed/load governing system and all of its associated equipment shall be carefully checked and properly adjusted prior to the tests. This shall be done according to the recommendations of the manufacturer with such assistance as may be required from the purchaser and with due consideration to operating requirements, so that the time required to check the mechanical conditions and make the necessary adjustments of the speed/load governing mechanism will not impose an unwarranted interruption on the normal operation of the unit.

3.03.3 Equipment and instruments should be examined thoroughly and calibrated to assure acceptability for the purposes of the tests. Spares for those instruments liable to failure or breakage in service should be provided and calibrated as part of the preparation for the tests.

3.04 Accuracy

3.04.1 The test readings shall be reported as observed, and the test results shall be reported as calculated, with such corrections as are permitted by this Code. The accuracy of the measurements affecting the results of the tests performed under this Code are covered under Section 4.

3.05 Preliminary Test

3.05.1 It is recommended that prior to the acceptance tests a preliminary test be run for the following purpose:

- (a) Checking the adjustment of the speed/load governing system and the turbine-generator to assure that the equipment is in suitable condition for a test.
- (b) Checking all instruments and methods of measurement.

- (c) Training personnel.
- (d) Establishing the test points.
- (e) Calculation of results as an overall check of procedure, layout, and organization.

3.05.2 If the parties to the tests agree, the preliminary test may be accepted as a final test.

3.06 Operating Conditions

3.06.1 Preparatory to a test the turbine-generator and associated equipment shall be operated for a sufficient time to attain steady-state operating conditions.

3.06.2 The operating conditions shall be maintained within limits prescribed in this and other appropriate ASME Performance Test Codes. Unless otherwise permitted by agreement between parties to the tests, the operating conditions shall not deviate from the specified conditions during the period of a test beyond the following limits:

- (a) Inlet steam pressure ahead of the throttle or stop valve shall be within plus or minus two (± 2) percent of the pressure specified in the test procedures.
- (b) Exhaust steam pressures of noncondensing turbines shall be within plus or minus two (± 2) percent of the pressures specified in the test procedures.
- (c) Exhaust steam pressures for condensing turbines vary with prevailing conditions. The tests shall be run as close to the rated exhaust pressure as practical.
- (d) Steam temperatures at the throttle/stop valves are related to the rate of steam generation and may vary with load. Temperatures shall be maintained at normal values as far as possible during the course of the testing. In any event great care shall be exercised to maintain steam conditions so that the temperatures at the throttle/stop valves will be free from any appreciable variations during the individual tests.
- (e) Steady-state speed shall not deviate from the specified value by more than plus or minus two-tenths (± 0.2) percent of rated speed (N_r).
- (f) Steady-state power output shall not deviate from the specified value by more than plus or minus one (± 1) percent.

3.06.3 Except as noted in Section 4, all tests are to be performed under normal operating conditions on governor control.

3.06.4 The normal variations from specified values of inlet pressure and temperature and exhaust pressure have negligible effects on speed/load governing system charac-

SPEED AND LOAD GOVERNING SYSTEMS FOR STEAM TURBINE-GENERATOR UNITS

teristics. Many turbine-generator units are started and operated at other than rated pressures and temperatures and the governor should be tested at these conditions as well as rated conditions.

3.06.5 The normal variations from specified values of voltage and power factor have negligible effects on speed/load governing system characteristics and may be adjusted to suit station conditions.

3.07 Instruments and Records

3.07.1 The accuracy ranges and responses of all instruments shall be as required in Section 4. Prior to the tests the initial calibrations of all the instruments shall be available and the methods of calibration shall be agreed upon by the parties to the tests.

3.07.2 Only such observations and measurements need to be made as apply and are necessary to attain the object of each test. Each observer shall record his actual observations on the test record and each of the parties to the tests shall receive a certified copy of the original test record. Corrections and corrected values shall be entered in the test record in such a manner that the original entry

remains legible and shall be accompanied by an explanatory note. Particular care should be taken to record any adjustments made to any equipment under test whether made prior to a run or between the runs. The reason for each adjustment shall also be stated in the test record.

3.07.3 Alternate methods are presented in this Code for certain tests and for computing their results. In these instances, the Test Report shall state which alternative has been employed.

3.08 Evaluation of Test Results

3.08.1 If the test results show malfunctioning of the unit or any auxiliaries the defects shall be corrected before the test series is repeated.

3.08.2 If during the conduct of a test, or during the subsequent analysis or interpretation of observed data an obvious inconsistency is found, the parties to the tests should make every reasonable effort to adjust or eliminate the inconsistency by mutual agreement. Failure to reach such an agreement shall require repetition of the test.

3.08.3 Contractual ramifications of the test results are outside the scope of this Code.

ASME PERFORMANCE TEST CODES

SECTION 4, INSTRUMENTS AND METHODS OF MEASUREMENTS

4.0 Selection of Instruments

4.01 General

4.01.1 This section describes the instruments required to determine the performance characteristics of a speed/load governing system. Unless otherwise specified herein, the instruments and their calibrations shall be in accordance with the Performance Test Code Supplements on Instruments and Apparatus (hereinafter referred to as I and A), (PTC 19).

4.01.2 Duplicate instrumentation may be installed to measure specific vital parameters if so desired and agreed to by the parties to the tests.

4.02 Measured Quantities

4.02.1 To determine the performance characteristics of the speed/load governing system, it is necessary to measure one or more of the following:

- (a) Pressure
- (b) Temperature
- (c) Speed and frequency
- (d) Motion or travel
- (e) Power output or electrical load
- (f) Time
- (g) Voltage
- (h) Current

4.03 Pressure Measurements

4.03.1 Measurements of steam pressures will be required to determine the operating conditions during the tests. It is desirable but not mandatory that the accuracy of pressure measurements conform with the requirements of the Test Code for Steam Turbines (PTC 6).

4.03.2 If it is not practicable to comply with the recommendations of Par. 4.03.1, calibrated station instruments may be used, subject only to the following:

- (a) For pressure above 35.0 psi (241.3 kPa) abs gages or transducers capable of being read within plus or minus one (± 1.0) percent of the pressure measured may be used.
- (b) For pressures at 35.0 psi (241.3 kPa) abs or less, mercury manometers or columns or equiv-

alent capable of being read within plus or minus two (± 2.0) percent of the pressure being read, or ± 0.1 in. (2.5 mm) Hg, whichever is greater, may be used.

4.04 Temperature Measurements

4.04.1 Measurement of steam temperatures will be required to determine the operating conditions during the tests. It is desirable but not mandatory that temperature measurements conform with the requirements of the Test Code for Steam Turbines (PTC 6).

4.04.2 If it is not practicable or convenient to comply with the recommendations of Par. 4.04.1, calibrated station instruments may be used subject to agreement by the parties to the test.

4.05 Speed or Frequency Measurements

4.05.1 Speed or generator frequency measurements are required to establish regulation and other measures of performance.

4.05.2 On an isolated system the measurement of frequency may take the place of speed measurement.

4.05.3 Continuous readout of speed on an electronic digital meter is recommended. However, any direct-reading speed measuring device may be used to determine speed or frequency. Whatever is used must meet the requirements hereinafter prescribed.

4.05.4 The use of multiple channel graphic recording instruments is required for determination of dead band, overspeed, speed/load band, step response and settling time, and for the simultaneous measurements of speed and power output, speed/load changer governing system reference or valve position demand signal.

4.05.5 The use of an X-Y recorder or multiple channel graphic recording instrument is required for the determination of steady-state speed regulation, speed versus servomotor position, and steady-state incremental regulation.

4.05.6 Speed measuring instruments shall meet the following requirements:

SPEED AND LOAD GOVERNING SYSTEMS FOR STEAM TURBINE-GENERATOR UNITS

Application	Suggested Range, Percent of Rated Speed	Maximum Error, Percent of Rated Speed	Maximum Dead Band, Percent of Rated Speed
Speed Regulation and Incremental Speed Regulation, Methods B & C	85 to 115	0.25	—
Overspeed	85 to 115	0.25	—
Range of Speed-Changer Adjustment	85 to 115	0.25	—
Dead Band	99 to 101	0.02	0.01
Incremental Speed Regulation, Method A	99 to 101	0.02	0.01
Steady State Governing Speed/Load Band	99 to 101	0.02	0.01
Adjustable Speed Functions	0 to 115	1.00	—

4.06 Motion or Travel Measurements

4.06.1 Measurement of motion will generally be limited to the measurement of the linear distance traveled by a device from a point of reference.

4.06.2 When required, the valve stroke can be established from the stroke of the servomotor piston.

4.06.3 For recorder input of servomotor travel, a travel pickup (potentiometer, or linear variable differential transformer) may be used. The servomotor travel should be measured to within ± 0.5 percent of full travel.

4.06.4 For direct measurement of servomotor travel use a scale with 0.02 in. or 0.5 mm divisions when travel is greater than 2.0 in. (50.8 mm), and use a dial indicator with 0.001 in. or 0.01 mm divisions when travel is less than 2.0 in. (50.8 mm).

4.06.5 The speed/load changer governing system reference or travel of the speed/load changer may be established by means other than those described in Par. 4.06.4, provided comparable accuracy is obtained.

4.06.4, provided comparable accuracy is obtained. For this purpose, a suitable position indicator, if provided with the speed/load changer, may be used. If the positioning of the speed/load changer is effected by a screw, its position may be established by counting the number of turns and fractions of turns as measured from either end of its travel.

4.07 Power Output Measurements

4.07.1 It is desirable but not mandatory that power output measurements conform with the requirements of the Test Code for Steam Turbines (PTC 6).

4.07.2 If it is not practicable or convenient to comply with the recommendations of Par. 4.07.1, calibrated station instruments may be used subject to agreement by the parties to the tests.

4.07.3 For the determination of steady-state governing load band, the recording wattmeter should have an accuracy of 1.0 percent of scale span. The response time and chart speed should be commensurate with the quantities being measured.

4.08 Time Measurements

4.08.1 Time measurement is required to establish settling time for transient oscillation, and to determine rates of change of valve position, voltage references, speed, load, and speed/load changer governing system reference.

4.08.2 In tests where recording instruments are used the chart speed should allow elapsed time to be read with an accuracy of ± 2.0 percent.

4.08.3 A stop watch may be used when determining the rate of change of functions with extended time duration, if so agreed by the parties to the tests.

4.09 Voltage Measurements

4.09.1 For testing of electronic control systems, measurement of control system references and variables are required. Some of these references and variables will normally be measured as voltages.

4.09.2 The accuracy and deadband of the voltage measuring instruments must be commensurate with the quantities being measured.

ASME PERFORMANCE TEST CODES

4.09.3 The use of voltage recording instruments is essential for determining the time dependency of the reference voltages.

4.10 Testing - General

4.10.1 As discussed in Section 3, the selection of tests to be performed on the unit should be based on the application of the steam turbine-generator.

4.10.2 The tests are listed in a logical order so that it is feasible to proceed sequentially through the required tests. However, except where the results of one test influence the procedure in a subsequent test, any sequence of testing agreed upon is satisfactory.

4.10.3 Certain test conditions and procedures are so related that it is more efficient, if two or more tests are to be performed, to conduct some or all of them concurrently. Reference to Table 7-33 in Par. 7.30 would be helpful in determining what tests can be run concurrently.

4.10.4 For each test the quantities to be recorded are itemized. When reference is made to operating point it is meant that the following items should be recorded:

- (a) General configuration, including whether the generator is operated isolated or synchronized, extraction and other valve positions affecting turbine performance, etc.
- (b) Turbine speed.
- (c) Electric load.
- (d) Steam conditions (pressure, temperature).
- (e) Steam flow.
- (f) Control settings.
- (g) Special conditions or deviations.
- (h) Controlling valve positions.
- (i) Conditions of hydraulic, pneumatic and electrical power supplies.

4.10.5 In all cases in which a recorder is used, preliminary tests shall be made to ascertain that the channel gains are commensurate with the magnitudes of the variable fluctuations recorded.

4.10.6 Instruments and recorders should have a response time and chart speed commensurate with the quantities being observed and recorded.

PROCEDURES

4.11 General

4.11.1 For taking the measurements specified in this section, the speed/load governing system shall be in service, and pressure regulating systems associated with the turbine shall be inoperative or out of service as con-

sistent with equipment protection in case of an emergency.

4.12 Determination of Adjustable Speed Functions

4.12.1 The purpose of these tests is to determine control system performance with respect to the following control features, as provided:

- (a) Speed/load changer minimum speed holding level.
- (b) Other speed holding levels.
- (c) Acceleration control.
- (d) Speed/load changer low speed limit.
- (e) Speed/load changer high speed limit.
- (f) Synchronizing speed range.
- (g) Maximum speed at rated power.

4.12.2 Equipment required:

Means for:

- (a) Direct reading and recording of speed (Par. 4.05).
- (b) Indication of speed/load changer governing system reference (Par. 4.06).
- (c) Indication of the position of governor-controlled valve(s) servomotor(s), (Par. 4.06).

4.12.3 Test conditions:

- (a) Unit generator main circuit breaker open, run up from rest, with hold and acceleration provisions operable, if provided.
- (b) Unit at rated speed, generator main circuit breaker open, and no load.

4.12.4 Determination of Speed/Load Changer Minimum Speed Holding Level

4.12.4.1 The purpose of this test is to determine the lowest steady-state speed level attainable under speed/load governor control with the speed/load changer set at the minimum speed holding level.

4.12.4.2 Test conditions are those specified under Par. 4.12.3(a). The following procedure applies:

- (a) If adjustable, preset turbine manufacturer's recommended acceleration rate.
- (b) Follow turbine manufacturer's operating instructions with respect to turning gear operation, rotor prewarming and general roll off procedures.

4.12.4.3 Record:

- (a) Speed of the turbine from roll-off to the point at which the turbine is at steady-state speed under control of the speed/load governing system.
- (b) Recorder range setting.
- (c) Speed reference set point.
- (d) Acceleration rate set point.
- (e) Inlet steam temperature and pressure.
- (f) Condenser pressure.

SPEED AND LOAD GOVERNING SYSTEMS FOR STEAM TURBINE-GENERATOR UNITS

(g) Speed/load changer governing system reference (if required).

4.12.4.4 For evaluation and computation of results, refer to Par. 5.12.4.

4.12.5 Determination of Other Speed Holding Levels

4.12.5.1 Speed holding levels are those speeds preselected by the turbine manufacturer where the turbine is to be held for warming turbine parts for finite time periods. These speed holding levels are outside of the critical speed zones of the turbine-generator unit.

4.12.5.2 This test applies when the speed holding levels are under control of the speed/load governor within or below synchronizing speed range.

4.12.5.3 This test normally follows the completion of the minimum speed holding level test in Par. 4.12.4.

4.12.5.4 This test will be conducted between various speed holding levels with preset acceleration rates. The combinations of speed holding level changes and acceleration rates to be tested will be agreed upon by the parties to the tests before the tests, in accordance with Par. 3.02. If desired, deceleration rates may also be checked.

4.12.5.5 The following procedure applies:

- (a) Preset acceleration or deceleration rate.
- (b) Preset new speed holding level and initiate speed change.

4.12.5.6 Record:

- (a) Speed of turbine from one speed holding level to another.
- (b) Recorder range setting.
- (c) Speed reference set point.
- (d) Acceleration rate set point.
- (e) Inlet temperature and pressure.
- (f) Condenser pressure.
- (g) Speed/load changer governing system reference (if required).

4.12.5.7 For evaluation and computation of results, refer to Par. 5.12.5.

4.12.6 Determination of Acceleration Control

4.12.6.1 Acceleration is the rate of change of rotational speed. When used in general, it applies to increasing and decreasing speed functions. When used specifically, acceleration is increasing and deceleration is decreasing speed. Deceleration is not necessarily under governor control and may be checked to provide operational information.

4.12.6.2 The performance of the speed/load governing system in controlling acceleration rates is tested in conjunction with:

- Par. 4.12.4—Minimum Speed Holding Levels
- Par. 4.12.5—Other Speed Holding Levels

4.12.6.3 This section does not cover nonsteady-state acceleration devices which are used for overspeed protection of the unit.

4.12.7 Determination of Speed/Load Changer Low Speed Limit

4.12.7.1 The low speed limit is the specified lower limit of the synchronizing speed range. This setting may be a manufacturer's recommended input rather than a physical limit or "stop." Test conditions are those under Par. 4.12.3(b).

4.12.7.2 The following procedure applies:

- (a) Set speed/load changer at low speed limit setting.
- (b) Record turbine steady-state speed and speed/load changer governing system reference. No computations are required.

4.12.8 Determination of Speed/Load Changer High Speed Limit

4.12.8.1 The high speed limit is the specified upper limit of the synchronizing range. This setting may be a manufacturer's recommended input rather than a physical limit or "stop." Test conditions are those specified under Par. 4.12.3(b).

4.12.8.2 The following procedure applies:

- (a) Set speed/load changer at high speed limit setting.
- (b) Record turbine steady-state speed and speed/load changer governing system reference. No computations are required.

4.12.9 Determination of Synchronizing Speed Range

4.12.9.1 The low and high speed limits determined by tests described in Pars. 4.12.7 and 4.12.8 are used to establish synchronizing speed range.

4.12.9.2 Not all speed/load governing systems have a synchronizing range defined by high and low speed limits. In these situations, synchronizing speed range is a preselected speed zone within which the unit may be synchronized with the system.

4.12.10 Determination of Maximum Speed at Rated Power

4.12.10.1 This section applies to a speed/load governing system with a high speed limit and the ability for

ASME PERFORMANCE TEST CODES

throttle valves to be operated independently of the speed/load governing system.

- 4.12.10.2 Test conditions are those specified under Par. 4.12.3(b). The following procedure applies:
- Set speed/load changer at high speed limit.
 - Reduce steam flow by closing the throttle/stop valve until the governor-controlled valves are at position corresponding to maximum rated power output at rated conditions.
 - Record governor-controlled valve position and speed as test results for (a) and (b) above.
 - No computations are required.

4.13 Determination of Steady-State Speed Regulation

4.13.1 The purpose of these tests is to determine the steady-state speed regulation.

4.13.2 Equipment required:

- X-Y recorder (preferred) or multiple channel strip recorders.
- Recorder for speed input.
- Recorder for valve position demand signal (displacement, voltage, pressure, etc.).
- Means for direct reading of speed.
- Recorder for unit load.

4.13.3 Test conditions:

- Unit at no load disconnected from the line at various speeds with governor-controlled valves controlling and unit on the line with various loads, or
- For automatic extraction and mixed pressure turbines, run the unit under various loads with zero extraction, including zero load.

4.13.4 Procedure:

- Operate the unit with generator main circuit breaker closed at steady-state rated speed and steady-state rated power output. Accurately establish the speed/load changer governing system reference.
- Operate the unit with generator main circuit breaker open at zero power output with governor-controlled valves controlling. When operating conditions become stabilized, preferably at rated steam conditions; the speed/load changer governing system reference should be set corresponding to the setting established in step (a), above.
- For automatic extraction or mixed-pressure turbines, run the unit under maximum permissible load without extractions. (Load to be agreed upon by parties to the tests).
- With the governor setting as in (c), above, op-

erate the unit at zero power output with zero extractions.

4.13.5 Record:

- The setting of the speed/load changer governing system reference in step (a) or (c) Par. 4.13.4.
- Initial steam conditions at no load in step (b) or (d) Par. 4.13.4.
- If not at rated steam conditions, record the valve position demand signal.
- Actual unit steady-state speed obtained in step (a) and (b) or (c) and (d) Par. 4.13.4.
- Actual maximum power output in step (c) Par. 4.13.4 if used.

4.13.6 Calculations are described in Par. 5.13.

4.14 Determination of Steady-State Incremental Speed Regulation

4.14.1 The purpose of these tests is to determine the steady-state incremental speed regulation.

4.14.1.1 There are two sets of operating conditions (Case I and Case II) that can be used for determining steady-state incremental speed regulation.

- Case I can be used where the turbine-generator can be run isolated and the load varied from zero to full load.
- Case II is used in all other instances, that is, the turbine-generator is loaded in parallel with one or more other units.

4.14.2 Equipment required:

- X-Y recorder (preferred) or multiple channel strip recorders.
- Recorder for speed input.
- Recorder for valve position demand signal (displacement, voltage, pressure, etc.).
- Recorder for unit load.
- Means for direct reading of speed.

4.14.3 Test conditions:

4.14.3.1 Case I:

- Unit operating isolated with various loads.

4.14.3.2 Case II:

- Unit at no load, generator main circuit breaker open at various speeds with governor-controlled valves controlling.
- Unit generator main circuit breaker closed with various loads.

4.14.3.3 In both cases, if load feedback signal is provided, it must be out of service.

SPEED AND LOAD GOVERNING SYSTEMS FOR STEAM TURBINE-GENERATOR UNITS

4.14.4 Procedure:

- (a) Determination of steady-state incremental speed regulation includes a graphical solution. This requires the preparation of curves.

4.14.4.1 Case I

With the unit running isolated under normal operating conditions and with the valve position limiter set out of range, place the speed governing system under control of the speed/load changer. Tests should be spaced to give at least six points in the range of power output resulting from the opening of each governor-controlled valve or valve set.

If steam generator limitations are such that the unit is unable to operate in the full range of power output while still maintaining rated conditions, then it would be acceptable to operate at less than rated conditions and apply a correction factor to the results.

4.14.4.2 Case II

This case requires preparation of two (2) curves.

(a) For Curve 1:

With the unit in parallel with other units under normal operating conditions and with the speed/load changer at the high speed limit, place the governor-controlled valves under control of the valve position limiter. Tests should be spaced to give at least six points in the range of power output, resulting in the opening of each governor-controlled valve or valve set.

If steam generator limitations are such that the unit is unable to operate in the full range of power output while still maintaining rated conditions, then it would be acceptable to operate at less than rated conditions and apply a correction factor to the results.

(b) For Curve 2:

There are three methods available for obtaining Curve 2: Method A, Method B, and Method C.

Method A

This method employs the frequency change of the system to determine a curve of speed versus valve position demand signal to the governor-controlled valves.

The tests should be run while the unit is operating in parallel with other units under governor system control at five test values of power output at approximately 5, 25, 50, 75 and 100 percent rated power output. Values of power output which lie within the top 10 percent of the increment of power output resulting from the opening of any governor-controlled valve should be avoided.

Test runs should be of sufficient duration to give a well defined diagram on the X-Y recorder. The speed/load changer governing system reference must be kept at a constant setting during each run.

Method B

This method employs the change in unit speed off the line by decreasing the steam supply to the governor-controlled valves. This method cannot be used except on those turbines where throttle and/or stop valves can be controlled independently of the governor. The unit should first be operated with the generator main circuit breaker closed at various loads. The setting of the speed/load changer governing system reference should be accurately determined for 25, 50, 75, and 100 percent of valve position demand signal to the governor-controlled valves.

The unit should then be operated with the generator main circuit breaker open with rated steam conditions. The speed/load changer governor system reference should be set to rated speed with zero power output. The steam supply should then be slowly decreased until the governor-controlled valves are fully open. This may be accomplished by closing the main stop valves. Reclose governor-controlled valves before re-establishing steam supply. The steam supply should then be re-established until rated conditions are reached.

The speed/load changer governing system reference should then be set at each of the four positions previously determined and the same procedure repeated for each position.

Method C

This method can be used only when the relation between the speed/load changer governing system reference and valve position demand signal is nearly linear. If the results of Method C (Par.

5.14.4.2(d)) indicate a difference between the actual curve and its tangent as illustrated in Fig. 5-10 of more than 0.5 percent speed at any speed/load changer governing system reference setting then Method A or Method B must be used.

The curve produced by this method can also be used to determine steady-state speed regulation.

Operate the unit with the generator main circuit breaker closed in parallel with other units. With steady-state speed, accurately record the setting of the speed/load changer governing system reference for 25, 50, 75 and 100 percent rated power output.

ASME PERFORMANCE TEST CODES

The unit generator main circuit breaker should then be opened, the unit run at zero load with rated main steam conditions and with the speed/load changer governing system reference set at each of the four positions determined in previous paragraph and the same procedure repeated for each position.

4.14.5 Record:**4.14.5.1 Case I:**

- (a) Power output
- (b) Speed
- (c) Initial steam pressure and temperature
- (d) Condenser pressure
- (e) Valve position demand signal

4.14.5.2 Case II:**(a) Curve 1 Governor-Controlled Valve Incremental Regulation**

(1)(a) *Preferred Method*—Using an X-Y recorder, the power output should be plotted on one axis and the valve position demand signal to the governor-controlled valves on the other axis.

(1)(b) *Alternate Method*—The reading of power output and valve position demand signal may be read and recorded on data log sheets.

(2) Main steam pressure and temperature, re-heat steam temperature and condenser vacuum at each load point.

(b) Curve 2 Speed/Load Governor Incremental Regulation**Method A**

An X-Y plotter should be used with unit speed on one axis and valve position demand signal to the governor-controlled valves on the other axis. Otherwise these values can be recorded on a strip chart recorder.

Method B

An X-Y plotter should be used with unit speed on one axis and valve position demand signal to the governor-controlled valves on the other axis. Otherwise these values can be recorded on a strip chart recorder.

Method C

The unit speed should be recorded corresponding to each of the speed/load changer governing system reference settings.

- (c) If rated main steam conditions are not obtainable, actual conditions should be recorded and

the valve position demand signal to the governor-controlled valves should be measured and recorded.

4.14.6 Calculations are described in Par. 5.14.**4.15 Determination of Dead Band**

4.15.1 The purpose of these tests is to determine dead band.

4.15.2 Equipment required:**(a) Method A**

Multiple channel strip recorder or X-Y recorder calibrated to simultaneously record speed and position of governor-controlled valves, means for direct reading of load.

(b) Method B

Multiple channel strip recorder or X-Y recorder, calibrated to simultaneously read speed and speed/load changer governing system reference for calibration; then governor-controlled valve position simultaneously with speed/load changer governing system reference, means for direct reading of load.

4.15.3 Test conditions:**(a) Method A**

Unit at rated speed, generator main circuit breaker closed, and carrying load.

(b) Method B

Unit at rated speed, generator main circuit breaker open, with governor-controlled valves controlling.

4.15.4 Procedure:**(a) Method A**

This method should be used when normal load variations will produce frequency changes of sufficient magnitude for the purpose of this test.

Simultaneously record speed and position of the governor-controlled valve(s). Readings should be taken at three loads: near no load, half load, and full load (and/or other load points that may be agreed upon by the parties to the tests).

(b) Method B

This method should be used when normal frequency variations are not of sufficient magnitude to permit determination of dead band.

- (1) With the unit running at 99 percent of rated speed (generator main circuit breaker open) record the change in speed versus the change in speed/load changer governing system ref-

SPEED AND LOAD GOVERNING SYSTEMS FOR STEAM TURBINE-GENERATOR UNITS

erence while both increasing and decreasing speed between 99 and 101 percent of rated speed. This step need not be repeated following each specified load point in step (2), below.

- (2) With the unit at rated speed, and at a previously agreed upon load, record the change in position of the governor-controlled valve(s) while changing the speed/load changer governing system reference, both in the increase and decrease direction. Speed/load changer governing system reference should not change at a rate faster than 2 percent rated speed per minute.

4.15.5 Record:

(a) Method A

- (1) Speed
- (2) Position of governor-controlled valve(s)
- (3) Load

(b) Method B

- (1) Setting of speed/load changer governing system reference
- (2) Position of governor-controlled valve(s)
- (3) Speed or frequency
- (4) Load

4.15.6 Calculations are described in Par. 5.15.

4.16 Determination of Steady-State Governing Speed Band

4.16.1 The purpose of this test is to determine the magnitude of steady-state fluctuations at rated speed. The test may be run in two ways: Method A is run with the generator main circuit breaker open operating at rated speed under governor control. Under this method, the value obtained is related only to one control valve setting. Method B is run with the machine isolated and carrying load. Under this method, varying values may be obtained at various loads, depending on the control valve system characteristics. If Method B is used the parties to the test must agree beforehand at what load(s) the test(s) are to be run.

Every effort should be made to eliminate or minimize fluctuations due to external disturbance.

4.16.2 Equipment required:

- (a) Strip chart recorder(s)
- (b) Recorder for speed
- (c) Recorder for unit load

4.16.3 Test conditions:

(a) Method A

- (1) Unit generator main circuit breaker open, zero power output, at rated speed under governor control, generator excited with normal field current.
- (2) Recorder connected to record speed.

(b) Method B

- (1) Unit isolated, carrying load as agreed upon by the parties to the tests, under governor control, generator excited with normal field current, manual voltage control.
- (2) Recorders connected to record speed and load.

4.16.4 Procedure:

- (a) At specified operating point obtain strip chart record of speed and other variables.
- (b) Obtain the best possible evaluation of fluctuations or cycling that can be attributed to the speed governing system only, discounting other sources.
- (c) Repeat the test, with the governor-controlled valves under the control of a valve position limiting device at the position corresponding to zero power output (Method A) or load point of the test (Method B).

4.16.5 Record:

- (a) Speed and load.
- (b) Recorder calibration so that chart can be read directly.

4.16.6 Calculations are described in Par. 5.16.

4.17 Determination of Steady-State Governing Load Band

4.17.1 The purpose of this test is to determine the magnitude of steady-state load fluctuations while the machine is running under governor control.

4.17.2 Equipment required:

- (a) Recorder for load
- (b) Recorder for speed

4.17.3 Test conditions:

4.17.3.1 Since the magnitude and frequency of fluctuations may vary dependent upon specific load and operating conditions, the load and operating conditions shall be agreed upon by the parties to the tests prior to the tests. Values of load which lie within the top 10 percent of the increment of load resulting from the opening of any governor-controlled valve should be avoided.

4.17.3.2 Unit operating with load, in parallel with other units, normal operating conditions, generator on manual voltage control.

ASME PERFORMANCE TEST CODES

4.17.4 Procedure:

- (a) With unit on governor control, simultaneously record unit power output and speed over a suitable period of time without changing the speed/load changer governing system reference.
- (b) With the governor-controlled valves under the control of a valve position limiting device and unit load essentially that of step (a), above, simultaneously record unit power output and speed over a suitable period of time.
- (c) Repeat steps (a) and (b) for each load at which the test is desired.

4.17.5 Record:

- (a) Unit load
- (b) Speed

4.17.6 Calculations are described in Par. 5.17.

4.18 Determination of Response and Settling Time

4.18.1 The purpose of this test is to determine the response of the speed/load governing system to a sudden change in load or speed/load changer governing system reference signal. The operating conditions, load point and amount and rate of load change must be agreed upon by the parties to the test.

4.18.2 Equipment required:

- (a) Multiple channel strip chart recorder for governor-controlled valve position, speed/load changer governing system reference signal and load change input signal.
- (b) Recorder for unit speed.
- (c) Recorder for unit load.

4.18.3 Test conditions:

- (a) Unit at rated speed, and loaded as agreed upon.
- (b) Recorder connected to record speed, load, governor-controlled valve position, speed/load changer governing system reference signal, and load change input signal changes.

4.18.4 Procedure:

- (a) Operate the recorder(s) to obtain an adequate record of steady-state conditions.
- (b) Apply the agreed-upon load change. The magnitude of the change should be larger than dead band and at a rate not to exceed control velocity saturation.
- (c) Run the recorder(s) until steady-state conditions are re-established.

4.18.5 Record for each test:

- (a) Initial and final steady-state load and speed.
- (b) Transient values of load change input signal, load and speed.

- (c) Governor-controlled valve position and speed/load reference signal.

4.18.6 Calculations are described in Par. 5.18.

4.19 Determination of Overspeed

4.19.1 The purpose of this test is to determine the response of the speed/load governing system on sudden and complete loss of full load and to establish the corresponding maximum speed rise.

4.19.1.1 Prior to conducting this test, agreement shall be reached between the manufacturer, supplier and user as to the specific conditions and methods of test and the determination of the results.

4.19.2 Equipment required:

- (a) Recorder for speed.
- (b) Recorder for position of all turbine inlet valves.
- (c) Recorder for load.
- (d) Provision for recording time of generator main circuit breaker opening in relation to (a), (b), and (c) above.

4.19.3 Test conditions:

- (a) Unit at rated speed, generator main circuit breaker closed and loaded as agreed upon, under speed/load governing system control; valve position limiter set at full open, turbine exhaust pressure at design conditions. If exhaust pressure design conditions are not attainable, prevailing conditions are acceptable, but must be corrected in calculating overspeed, Pars. 5.19.2 and 5.19.3.

4.19.4 Procedure:

4.19.4.1 Prior to the test, the entire turbine-generator control system should be checked to assure that it is in proper adjustment and in good working order. The testing of the emergency overspeed trip should be made in accordance with PTC 20.2 before proceeding with this test. Specific tests should be made for proper operation of all turbine-generator back-up auxiliary systems, such as back-up lubricating oil pumps, auxiliary back-up electric power supply, turbine steam inlet valves, and other functions as described in the manufacturer's instruction book.

4.19.4.2 When the governing control system includes an overspeed control function, a preliminary test should be conducted at a load point just above the load at which this overspeed control functions.

4.19.4.3

- (a) After preparations have been completed for this test, it is advisable first to open the gen-

SPEED AND LOAD GOVERNING SYSTEMS FOR STEAM TURBINE-GENERATOR UNITS

erator main circuit breaker suddenly at approximately one-quarter full load to ascertain satisfactory functioning of equipment.

- (b) Observe and record the speed rise.
- (c) Check that all control systems and equipment function properly.
- (d) If the preliminary test is satisfactory, the full load rejection test may be run.
- (e) With unit carrying full load, operating conditions normal, open the generator main circuit breaker.

4.19.5 Record:

- (a) Speed.
- (b) Steam inlet valve positions.
- (c) Load.
- (d) Generator main circuit breaker position.
- (e) Overspeed control function output.
- (f) Turbine exhaust steam pressure and temperature prior to test.
- (g) Extraction check and stop valve positions.

4.19.6 Calculations are described in Par. 5.19.

4.20 Determination of Speed/Load Changer Governing System Reference Reducing Time

4.20.1 The purpose of this test is to determine the time

required to reduce the speed/load changer governing system reference from rated power output signal to zero power output signal by operating the speed/load changer continuously at its maximum rate of change.

4.20.2 Equipment required:

- (a) Recorder calibrated for speed/load changer governing system reference.

4.20.3 Test conditions:

- (a) Unit disconnected from the line.

4.20.4 Procedure:

- (a) Determine the values of the speed/load changer governing system reference corresponding to rated power output (P_r), (Par. 4.13.4(a)) and zero power output (P_0), (Par. 4.13.4(b)).
- (b) Record the change in the speed/load changer governing system reference from the rated power output value to the zero power output value, while the speed/load changer is operated at its maximum rate of change.

4.20.5 Record:

- (a) Time elapsed from rated power value to zero power value of speed/load changer governing system reference.

ASME PERFORMANCE TEST CODES

SECTION 5, COMPUTATION OF RESULTS

5.0 General

5.01 The tests performed as described in Section 4 are evaluated as described in the following paragraphs.

5.02 Paragraph numbers for the computations of a particular test correspond with the numbers of the description of that test in Section 4.

5.1 Evaluation of Results

5.12 Adjustable Speed Functions

5.12.4 Minimum speed holding level:

(a) Typical recorder chart

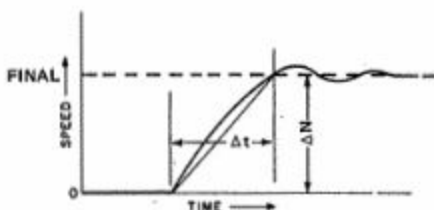

FIG. 5-1

(b) Evaluation

- (1) Draw a line at the steady-state value and read the minimum speed holding level from the chart.
- (2) Draw a straight line from the zero intercept to a point where the recorded speed line intercepts the steady-state value line at the first point in time.
- (3) Compute average acceleration

$$a = \frac{\Delta N}{\Delta t}$$

5.12.5 Other speed holding levels:

(a) Typical recorder chart, speed increasing

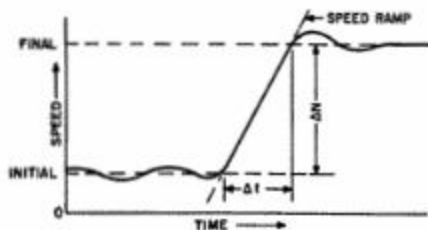

FIG. 5-2

(b) Evaluation

- (1) Draw a line at the steady-state value of initial speed and steady-state value of final speed and read off chart.
- (2) Draw a line which is representative of the speed ramp on the chart.
- (3) Compute average acceleration.

$$a = \frac{\Delta N}{\Delta t}$$

5.13 Steady-State Speed Regulation

5.13.1 The steady-state speed regulation is determined by substituting the data from Par. 4.13 in the appropriate formula below. Also note that if other than rated steam conditions exist during the test, N_0 and N_r must be calculated.

5.13.12 For automatic extraction or mixed-pressure turbines:

$$R_s = \frac{N_0 - N_m}{N_r} \times \frac{P_r}{P_m} \times 100 \text{ (percent)}$$

5.13.13 All other turbines:

$$R_s = \left(\frac{N_0}{N_r} - 1 \right) \times 100 \text{ (percent)}$$

(Note: This applies when $N_r = N$.)

5.14 Steady-State Incremental Speed Regulation

5.14.4 There are two sets of operating conditions (Case I and Case II) that can be used for determining steady-state incremental speed regulation (refer to Par. 4.14).

5.14.4.1 Case I. Plot percent speed versus percent power output (see Fig. 5-3 for example). The steady-state incremental speed regulation at a specific power output is the slope of the curve at the specific power output.

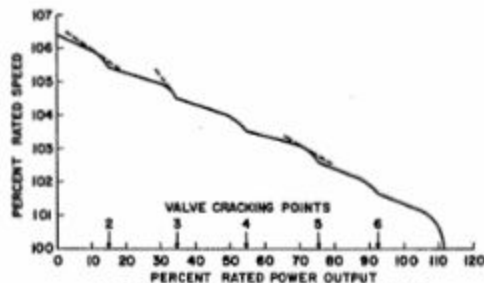

FIG. 5-3 CASE I - LINEAR GOVERNOR

SPEED AND LOAD GOVERNING SYSTEMS FOR STEAM TURBINE-GENERATOR UNITS

Plot a curve of steady-state incremental speed regulation versus percent power output (see Fig. 5-4 for example).

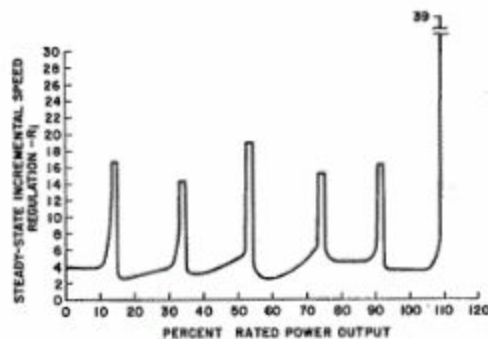

FIG. 5-4 CASE I - LINEAR GOVERNOR

(N_r) at the intersection of the center line and the rated speed (N_r) ordinate. (see Fig. 5-6 for example).

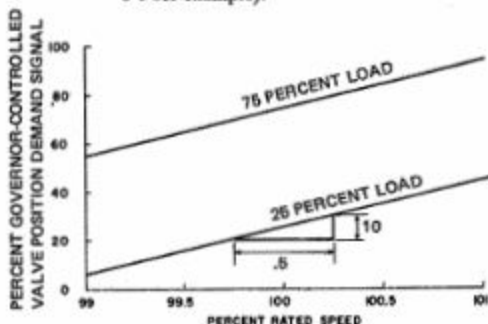

FIG. 5-6 CASE II - CURVE 2 - METHOD A

5.14.4.2 Case II:

- (a) Curve 1 (see Fig. 5-5 for example). To determine Curve 1 the values of power output obtained under Par. 4.14.4.2(a) should be corrected to normal conditions using appropriate correction data (see PTC 6). Convert these corrected values to percent rated power output, P_r . Plot the percent valve position demand signal against percent rated power output. The governor-controlled valve incremental factor R_v is the slope of the curve at a specific valve position demand signal.

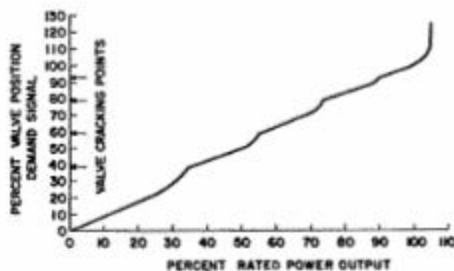

FIG. 5-5 CASE II - CURVE 1 - NONLINEAR GOVERNOR

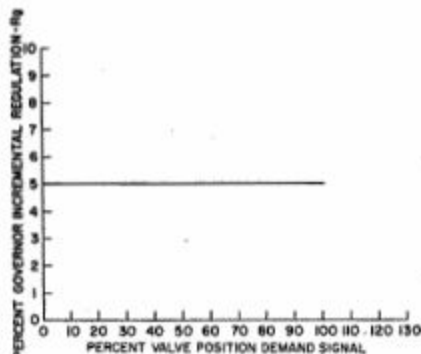

FIG. 5-7 CASE II - CURVE 2 - METHOD A

- (b) Curve 2—Method A. The following computations determine Curve 2 for Method A (Par. 4.14.4.2(b)).
- (1) Draw a center line through the diagram produced on each chart of the X-Y instrument and determine the value of the valve position demand signal corresponding to rated speed

- (2) For each chart, select two (2) points on the center line drawn through the diagram. Determine the percent speed and the corresponding percent valve position demand signal for each point. Determine the governor incremental speed regulation (R_g) from the following formula:

$$R_g = \frac{\text{Change in percent speed}}{\text{Corresponding change in percent valve position demand signal}} \times 100 \text{ (percent)}$$

- (3) Plot the values of regulation (R_g) obtained from step (2), above, against corresponding values of percent governor-controlled valve position demand signal determined in step (1), above. A line drawn through these points is Curve 2 (see Fig. 5-7 for example).

ASME PERFORMANCE TEST CODES

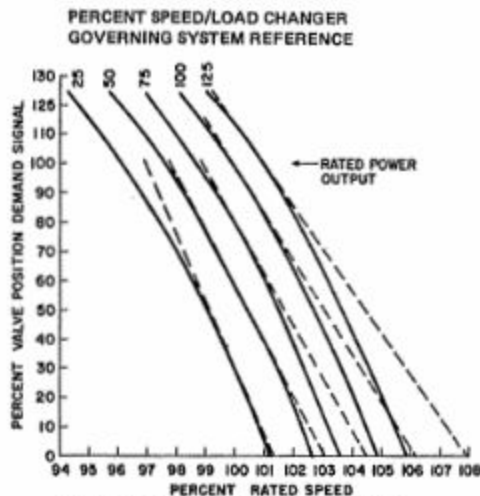

FIG. 5-8 CASE II - CURVE 2 - METHOD B

(c) Curve 2—Method B. The following computations determine Curve 2 for Method B. (Par. 4.14.4.2(b)).

- (1) The speed data obtained in Par. 4.14.4.2(b) should be converted to percent of rated speed. For the speed/load changer governing system reference corresponding to each one of the load points, plot a curve of valve position demand signal in percent of total signal corresponding to a change in power output from P_0 to P_r versus speed (percent of rated speed, N_r). (see Figure 5-8 for example).
- (2) For each speed versus valve position demand signal line corresponding to a specific speed/load changer governing system reference, draw a tangent at the point where the line crosses the rated speed (N_r) ordinate.
- (3) Extend each tangent so that the end points correspond to zero power output (P_0) and rated power output (P_r). The difference in the speeds at the end points of each tangent is the governor incremental speed regulation (R_g) corresponding to the valve position demand signal at the point of tangency.
- (4) Plot the values of regulation (R_g) obtained in step (3), above, against corresponding values of percent valve position demand signal determined in step (3), above. A line drawn through these points is Curve 2 (see Fig. 5-9 for example).

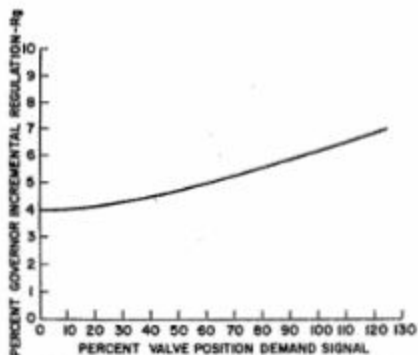

FIG. 5-9 CASE II - CURVE 2 - METHOD B

(d) Curve 2—Method C

- (1) Convert the value of speed to percent of rated speed for each speed/load changer governing system reference corresponding to the 25, 50, 75 and 100 percent rated power output points as determined in Par. 4.14.4.2 (b). Plot the valve position demand signal corresponding to each speed/load changer governing system reference as a function of percent rated speed.
- (2) Establish a tangent at the point where the graph crosses the rated speed (N_r) line at P_0 . Extend the tangent to rated power output (P_r). Determine the difference in speed between P_0 and P_r on the tangent. If the difference between the actual curve and its tangent, as illustrated in Fig. 5-10, is one-half percent or less at any speed/load changer governing system reference, then the governor incremental speed regulation

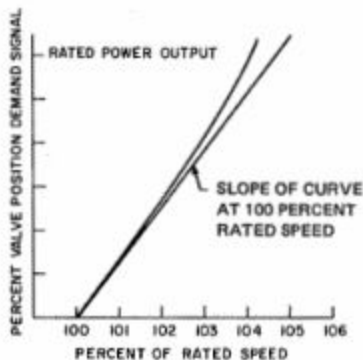

FIG. 5-10 CASE II - CURVE 2 - METHOD C

SPEED AND LOAD GOVERNING SYSTEMS FOR STEAM TURBINE-GENERATOR UNITS

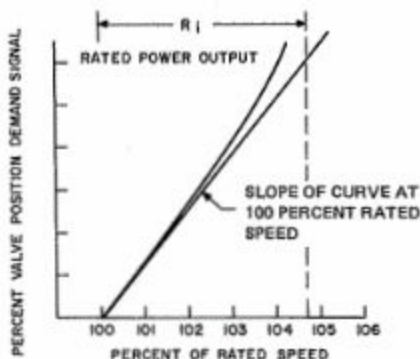

FIG. 5-11 CASE II - CURVE 2

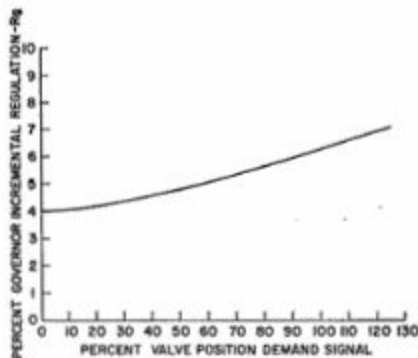

FIG. 6-13 CASE II - CURVE 2

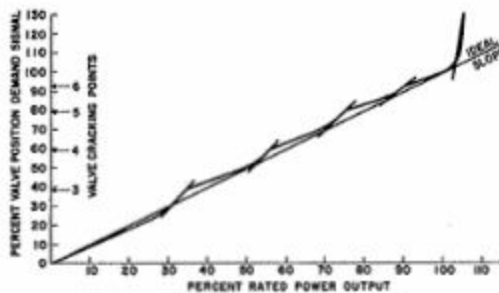

FIG. 5-12 CASE II - CURVE 1

(R_g) can be assumed to be constant and its value is the percent speed difference between P_0 and P_r on the tangent.

- (c) The steady-state incremental speed regulation would have the values shown on Curve 2 (see Fig. 5-11) if a straight line relationship held between valve position demand signal and power output. Since this is seldom true, it is necessary to modify Curve 2 using Curve 1 as follows:
- (1) At any assumed point on Curve 1, the deviation of the valve position demand signal versus power output curve from the ideal straight line relationship can be expressed mathematically by the governor-controlled valve incremental factor (R_v). To determine R_v enter Curve 1 for the desired percent power output. Determine the corresponding valve position demand signal and R_v , as illustrated in Fig. 5-12. R_v is the slope of

the tangent to the valve position demand signal curve at the desired percent power output (see Fig. 7-15 for numerical example).

- (2) Using the valve position demand signal determined in step (1), above, enter Curve 2 and obtain the corresponding value of governor incremental speed regulation, R_g , as illustrated in Fig. 5-13.
- (3) To compute percent steady-state incremental regulation, R_i , for each desired percent power output, multiply the corresponding values of R_v and R_g as obtained in steps (1) and (2), above. The selection of percent power output points on Curve 1 should be such as to reflect change in slope (R_v). If the slope is changing rapidly, the percent power points should be close together; if not, the points may be further apart. Tabulate percent power, R_g , R_v , and R_i . If desired these data may be plotted, as shown in the example in Fig. 5-14.
- (4) On a multi-valve unit, the governor-controlled valve incremental factor, R_v , used to determine the average value of the incremental regulation for the last 10 percent of power output resulting from the opening of any governor-controlled valves is obtained from the slope of the line drawn through the end points of this last 10 percent.

5.15 Dead Band

5.15.1 The purpose of these calculations is to determine dead band from the data recorded in Par. 4.15.

5.15.2 There are two methods of calculating dead band: Method A and Method B.

ASME PERFORMANCE TEST CODES

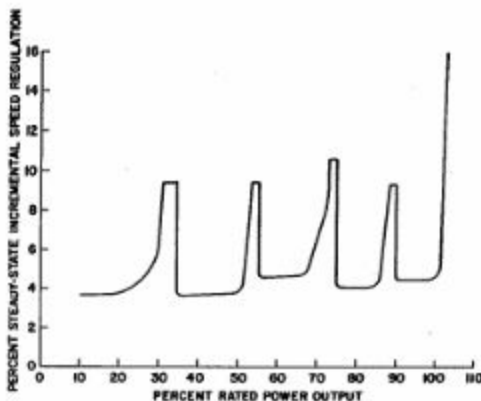

FIG. 5-14

(a) Method A

From the recorded data obtained under Par. 4.15.4(a), determine the change in speed for which there was no corresponding change in the position of the governor-controlled valve(s), (ΔN). Choose only those portions of the records where the speed is changing at a fairly constant and slow rate. The percent dead band will then be:

$$N_d = \frac{\Delta N}{N_r} \times 100 \text{ (percent)}$$

(b) Method B

From the recorded data obtained under Par. 4.15.4(b) establish a speed/load changer governing system reference calibration in convenient units.

The linearity of the speed/load changer governing system reference should be verified and the calibration constants determined for both the increase (C_i) and decrease (C_d) direction.

From the recorded data obtained under Par. 4.15.4(b) determine the change in the speed/load changer governing system reference for which there was no corresponding change in the governor-controlled valve(s) position for both increase and decrease (δN) speed setting directions. Choose only those portions of the records where the speed/load changer governing system reference was changed at a fairly constant and slow rate. The percent dead band will then be:

in the increase direction

$$N_d = \frac{C_i \times \delta N}{N_r} \times 100 \text{ (percent)}$$

in the decrease direction

$$N_d = \frac{C_d \times \delta N}{N_r} \times 100 \text{ (percent)}$$

Choose the larger of the two calculated values as the determined dead band (N_d).

5.16 Steady-State Governing Speed Band

5.16.1 The purpose of this calculation is to determine the steady-state governing speed band from the data recorded in Par. 4.16.

5.16.2 There are two (2) methods of testing for steady-state governing speed band (Par. 4.16.1). Calculation for each method is identical.

5.16.2.1 Deduct the peak-to-peak amplitude of the oscillations in speed found under Par. 4.16.4(c) from the peak-to-peak amplitude found under Par. 4.16.4(a). Convert the largest difference to percent rated speed.

$$\Delta N_B = \frac{\Delta N}{N_r} \times 100 \text{ (percent)}$$

5.17 Steady-State Governing Load Band

5.17.1 The purpose of this calculation is to determine the steady-state governing load band from the data recorded in Par. 4.17.

5.17.2 There are two methods of calculating steady-state governing load band: Method A and Method B.

(a) Method A

If the system frequency is constant, deduct the peak-to-peak amplitudes of power change found under Par. 4.17.4(b) from the peak-to-peak amplitudes found under Par. 4.17.4(a) at agreed-to load points. Convert the largest difference to percent of rated power.

(b) Method B

If the system frequency is varying with power changes, as found under Par. 4.17.4(a), consider phase relation of speed to governor-controlled valve motions and incremental speed regulation for the test load. The amplitudes of the power oscillations in excess of that accounted for by the corrective governor action via incremental speed regulation are attributable to governor load band. The steady-state governing-load band is therefore:

$$\Delta P_B = \delta P - \frac{\delta N}{R_f} \times 100 \text{ (percent)}$$

where: δP = Overall power swing expressed in percent of rated power output (P_r).

δN = Speed swing in percent of rated speed (N_r).

SPEED AND LOAD GOVERNING SYSTEMS FOR STEAM TURBINE-GENERATOR UNITS

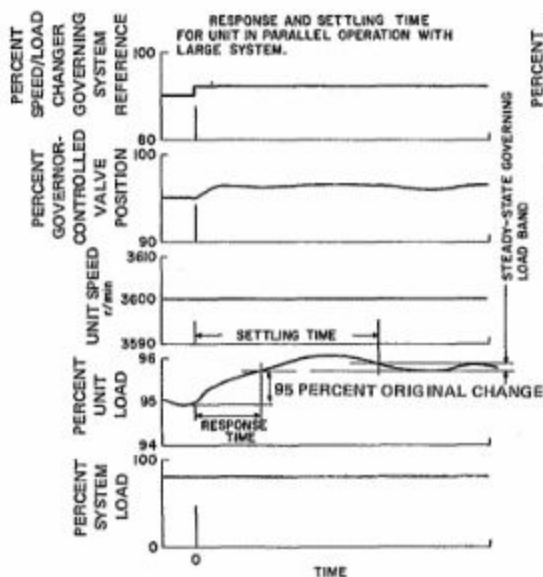

FIG. 5-15

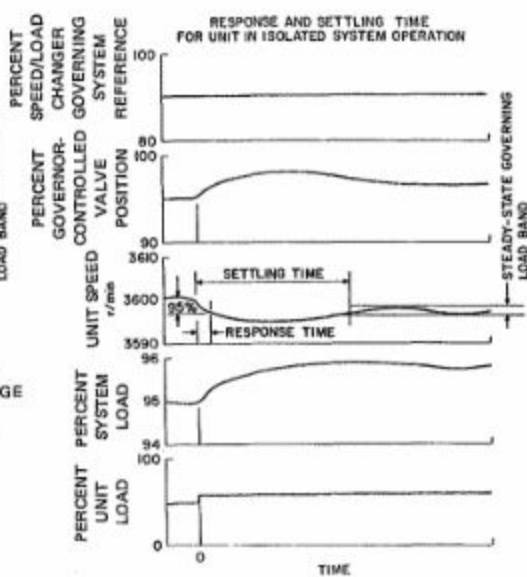

FIG. 5-16

5.18 Response and Settling Time

5.18.1 The purpose of this calculation is to determine the response and settling time from the data recorded in Par. 4.18.

5.18.2 The determination of response and settling time is made utilizing a graphical method using the charts produced in Par. 4.18. See the examples illustrated in Figs. 5-15 and 5-16.

5.19 Overspeed

5.19.1 The purpose of this calculation is to determine overspeed from the data recorded in Par. 4.19.

5.19.2 The percent overspeed is obtained by substituting the data from Par. 4.19 in the following formula:

$$\Delta N_L = \frac{N_{\max} - N_r}{N_r} \times 100 \text{ (percent)}$$

where N_{\max} = maximum speed attained after sudden and complete loss of power output.

5.19.3 If turbine exhaust conditions prior to test were not at design, correction to design conditions must be made (Ref. PTC 6).

5.20 Speed/Load Changer Governing System Reference Reducing Time

5.20.1 Governing system reference reducing time is determined directly from the recorded data obtained in Par. 4.20.

ASME PERFORMANCE TEST CODES

SECTION 6, REPORT OF RESULTS

6.0 General

6.0.1 The Report of Tests shall be prepared for the purpose of formally recording observed data and computed results. It shall contain sufficient supporting information to prove that all objectives of any tests conducted in accordance with this Code have been attained.

6.0.2 Only items required to satisfy the stipulated objectives need be recorded and reported.

6.0.3 The complete Report of Tests may contain, in addition to the tabulated test results, authenticated copies of the original log sheets and charts. Instrument readings shall be recorded as observed. Corrections and corrected values shall be entered separately in the test record.

6.1 Test Report Form

6.1.1 Tests shall be reported in accordance with the applicable portions of the form presented herewith and shall include the following parts in the order given:

- (a) Objects
- (b) Results
- (c) Conclusions
- (d) Authorization and Agreement
- (e) Description of Equipment
- (f) Methods of Tests
- (g) Summary of Measurements
- (h) Methods of Calculation
- (i) Application of Correction Factors
- (j) Allowances
- (k) Test Results
- (l) Presentation of Test Results
- (m) Discussion
- (n) Appendix

6.1.2 *Objects of Tests.* This part shall include an explicit statement of the objects of the tests covered in the report, as set forth in Par. 3.02.1.

6.1.3 *Results.* This part shall include a brief summary of the results obtained.

6.1.4 *Conclusions.* This part shall include conclusions concerning the results of the tests and any recommendations or supplementary comments.

6.1.5 *Authorization and Agreement.* This part shall include authorization for the tests, their objects, contractual obligations and guarantees, stipulated agreements, by whom the tests are directed, and the representative parties to the tests, as set forth in Par. 3.02.2.

6.1.6 *Description of Equipment.* This part shall include a description of the equipment tested and any other auxiliary apparatus, the operation of which may have influenced the test results.

6.1.7 *Methods of Tests.* This part shall include the methods of tests, giving the arrangement of testing equipment, instruments used and their locations, operating conditions, and a complete description of any methods of measurement used that are not prescribed by this Code.

6.1.8 *Summary of Measurements.* This part shall include a general log of the tests, recording the ambient conditions, the operating conditions of the turbine-generator unit, adjustments of the governor, and other system parameters.

6.1.9 *Methods of Calculation.* This part shall include a description of the methods of calculation from observed data and agreements as to precision and accuracy.

6.1.10 *Application of Correction Factors.* This part shall include a description as to how correction factors are to be applied because of deviations, if any, of test conditions from those specified.

6.1.11 *Allowances.* This part shall include the specified or agreed allowances for possible errors, including the methods of application. It is suggested that PTC 6 Report-1969, "Guidance for Evaluation of Measurement Uncertainty in Performance Tests of Steam Turbines," be used as a guide.

6.1.12 The test results shall be stated under the following headings:

6.1.12.1 Test Results computed on the basis of the test operating conditions, instrument calibrations only having been applied.

6.1.12.2 Test Results corrected to specified conditions if test operating conditions have deviated from those specified.

6.1.12.3 Statement that foregoing results, if limits of error have been agreed upon, are believed correct within a stated plus or minus percentage error or points on a percentage scale if the results are reported upon a percentage basis.

6.1.13 *Presentation of Test Results.* This section shall include tabular and graphical presentations of the test results.

6.1.14 *Discussion.* This section shall include a discussion of the tests, their results and conclusions.

ASME PTC*20.1 77 ■ 0759670 0052873 7 ■

SPEED AND LOAD GOVERNING SYSTEMS FOR STEAM TURBINE-GENERATOR UNITS

6.1.15 Appendix. This section shall include Appendices and illustrations to clarify the descriptions of equipment and the methods and circumstances for the tests, chronological log of events during tests, descriptions of methods of calibration of instruments, calibration reports, outline of details of calculations including a sample set of com-

putations, descriptions and statements as to special testing apparatus, results of preliminary inspections and trials, and any supporting information required to make the report a complete, self-contained document of the entire undertaking.

ASME PERFORMANCE TEST CODES

SECTION 7, APPENDIX

7.01 This appendix is included to provide information supplemental to that in Sections 1 through 6 as an aid to the user of this Code.

7.01.1 The following information is included in Section 7.

- (a) Numerical examples of calculations in Section 5 (Par. 7.10).
- (b) Illustrative diagrams, including description of MH and EH governing systems (Par. 7.20).
- (c) Instrumentation diagrams (Par. 7.30).
- (d) Indirect test methods (Par. 7.40).
- (e) Step/ramp transform (Par. 7.50).

7.10 Numerical Examples of Calculations in Section 5

7.10.1 Paragraph numbers showing the numerical examples for calculations in Section 5 correspond with the paragraph numbers of that calculation described in Section 5.

7.14 Sample Calculation of Steady-State Incremental Speed Regulation

7.14.1 Steady-state incremental speed regulation is defined in Par. 2.03.4. It can be considered as made up of two components:

- (a) Governor incremental speed regulation defined in Par. 2.03.15.
- (b) Governor-controlled valve incremental factor defined in Par. 2.03.2.

All of these values may be necessary to isolate the causes of unexplained instabilities which may occur in a system. The importance of testing for incremental regulation is principally in resolving governing system problems. The governor incremental regulation would include nonlinearities in the control system bounded from the speed feedback signal to the valve position demand signal. The governor-controlled valve incremental factor would include nonlinearities from the valve position demand signal to the actual load. The two components considered together establish the steady-state incremental speed regulation which covers the overall system from speed feedback to the power generated.

7.14.4.1 Case I—Isolated Unit. With the turbine-generator main circuit breaker closed but isolated from other generating units vary the load from zero to maximum power output and record speed and power output from which percent of rated speed and percent of rated power output are calculated, as illustrated in Table 7-1.

From Table 7-1 percent rated speed versus percent rated power output is plotted, as shown in Fig. 7-2.

After plotting the curve determine the slope as illustrated.

Table 7-3 contains the steady-state incremental speed regulation values for various load points while Fig. 7-4 is the plot of steady-state incremental speed regulation versus percent rated power output.

Note that this example applies to a specific governor.

7.14.4.2 Case II— This case requires preparation of two (2) curves.

(a) *For Curve 1*

With the unit in parallel with other units under normal operating conditions, vary the load from zero to maximum power output and record valve position demand signal and power output. From this, the percent valve position demand signal (100 percent valve position demand signal equals 100 percent rated power output) and percent rated power output are calculated, as illustrated in Table 7-5.

From Table 7-5 plot Curve 1 which is percent valve position demand signal versus percent rated power output, as illustrated in Fig. 7.6.

(b) *Case II—Curve 2—Method A.* From the X-Y plot in Fig. 7-7 determine the governor incremental regulation (R_g) as illustrated, and then plot versus percent valve position demand signal, as illustrated in Fig. 7-8.

(c) *Case II—Curve 2—Method B.* With the unit generator main circuit breaker open and the speed/load changer governing system reference set at each of the required points, valve position demand signal and speed are recorded, as illustrated in Table 7-9. From the recorded data, percent valve position demand signal and percent rated speed are calculated.

From the values in Table 7-9 percent valve position demand signal versus percent rated speed is plotted, as illustrated in Fig. 7-10; and then governor incremental regulation R_g is computed and plotted versus percent valve position demand signal, as illustrated in Fig. 7-11.

(d) *Case II—Curve 2—Method C.* With the turbine-generator main circuit breaker closed and paralleled with other generating units vary the load from zero to maximum power output and record valve position demand signal and speed/load changer governing system reference corre-

ASME PTC*20.1 77 ■ 0759670 0052875 0 ■

SPEED AND LOAD GOVERNING SYSTEMS FOR STEAM TURBINE-GENERATOR UNITS

TABLE 7-1 CASE I

Rated Power Output = 30 MW

Rated Speed = 3,000 r/min

Speed r/min	Power Output MW	Percent Rated Speed* (Speed ÷ 3000)	Percent Rated Power Output* (Power Output ÷ 30)
3000	33.5	100.00	111.7
3021	33.0	100.70	110.0
3030	32.0	101.00	106.7
3036	31.0	101.20	103.3
3040	30.0	101.33	100.0
3046	28.5	101.53	95.0
3050	27.6	101.67	92.0
3055	27.0	101.83	90.0
3061	26.2	102.03	87.3
3065	25.5	102.17	85.0
3072	24.0	102.40	80.0
3075	23.2	102.50	77.3
3080	22.5	102.67	75.0
3084	22.2	102.80	74.0
3085	22.0	102.83	73.3
3091	21.0	103.03	70.0
3095	20.0	103.17	66.7
3099	18.8	103.30	62.7
3101	18.0	103.37	60.0
3103	17.0	103.43	56.7
3105	16.5	103.50	55.0
3110	16.0	103.67	53.3
3117	15.0	103.90	50.0
3123	13.8	104.10	46.0
3130	12.0	104.33	40.0
3134	10.5	104.47	35.0
3141	10.0	104.70	33.3
3148	9.0	104.93	30.0
3153	7.5	105.10	25.0
3158	6.0	105.27	20.0
3160	5.0	105.33	16.7
3162	4.5	105.40	15.0
3168	4.2	105.60	14.0
3173	3.6	105.77	12.0
3177	3.0	105.90	10.0
3192	0	106.40	0.0

*Percent rated speed = $\frac{r/min}{3000} \times 100$

Percent rated power output = $\frac{MW}{30} \times 100$

ASME PERFORMANCE TEST CODES

TABLE 7-3 CASE I

NOTE:
THE SLOPE USED TO DETERMINE THE INCREMENTAL REGULATION FOR THE LAST 10 PERCENT OF POWER OUTPUT RESULTING FROM THE OPENING OF ANY GOVERNOR-CONTROLLED VALVE ON A MULTI-VALVE UNIT IS OBTAINED FROM THE SLOPE OF THE LINE DRAWN THROUGH THE END POINTS OF THIS LAST 10 PERCENT

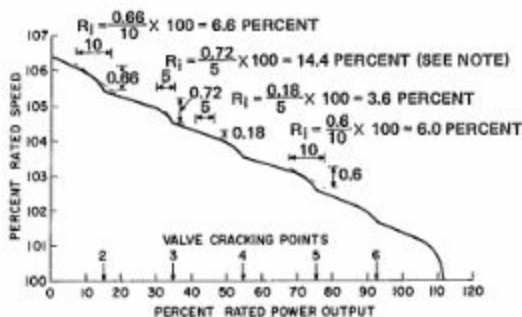

FIG. 7-2 CASE I

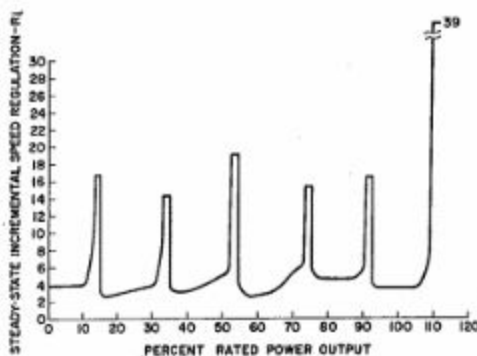

FIG. 7-4 CASE I

Percent Rated Power Output	Steady-State Incremental Speed Regulation (Slope from Fig. 7-2)
5.0	3.85
10.0	3.90
12.0	6.60
13.0	9.90
13.5	16.75
15.0	16.75
17.5	2.65
20.0	3.00
25.0	3.40
27.5	3.75
30.0	3.90
32.0	6.65
32.8	14.40
34.8	14.40
37.5	3.35
42.5	3.60
50.0	5.10
51.5	5.20
52.5	19.00
54.5	19.00
57.5	2.55
62.5	2.95
67.5	4.10
70.0	5.25
72.5	6.05
73.4	15.25
75.5	15.25
77.5	4.60
82.5	4.60
87.5	4.60
90.0	6.00
90.8	16.40
92.5	16.40
95.0	3.60
97.5	3.60
100.0	3.60
102.5	3.60
105.0	3.60
107.5	5.25
109.0	11.20
109.6	39.00
111.5	39.00

SPEED AND LOAD GOVERNING SYSTEMS FOR STEAM TURBINE-GENERATOR UNITS

TABLE 7-5 CASE II

Rated Power Output = 220 MW

Valve Position Demand Signal				
Valve Position Demand Signal Gross Inches*	Power Output MW	Net Inches* (Gross Inches - 0.60)	Percent (Net Inches* + 5.00)	Percent Rated Power Output (Power Output ÷ 220)
0.60	0.0	0.00	0.0	0.00
1.10	25.3	0.50	10.0	11.50
1.35	37.4	0.75	15.0	17.00
1.60	49.5	1.00	20.0	22.50
1.85	60.0	1.25	25.0	27.27
2.10	67.7	1.50	30.0	30.77
2.35	72.6	1.75	35.0	33.00
2.60	80.3	2.00	40.0	36.50
3.10	110.0	2.50	50.0	50.00
3.35	117.7	2.75	55.0	53.50
3.60	124.3	3.00	60.0	56.50
3.85	143.0	3.25	65.0	65.00
4.00	145.2	3.40	68.0	66.00
4.10	150.7	3.50	70.0	68.50
4.35	159.5	3.75	75.0	72.50
4.60	165.0	4.00	80.0	75.00
4.85	181.5	4.25	85.0	82.50
4.97	189.0	4.37	87.4	85.91
5.10	194.5	4.50	90.0	88.41
5.22	198.0	4.62	92.4	90.00
5.40	208.0	4.80	96.0	94.55
5.50	213.5	4.90	98.0	97.05
5.60	220.0	5.00	100.0	100.00
5.72	223.5	5.12	102.4	101.59
5.85	226.5	5.25	105.0	102.95
6.10	228.8	5.50	110.0	104.00
6.85	230.3	6.25	125.0	104.68

Note: An adjustment is made to the valve position demand signal for the amount of signal required to maintain synchronous speed. Also, note that 5.00 in. (127 mm) is the valve position demand signal corresponding to rated power output.

$$\text{Percent valve position demand signal} = \frac{\text{in.}}{5.0} \times 100$$

or

$$\frac{\text{mm}}{127} \times 100$$

$$\text{Percent rated power output} = \frac{\text{MW}}{220} \times 100$$

*1 in. = 25.4 mm

ASME PERFORMANCE TEST CODES

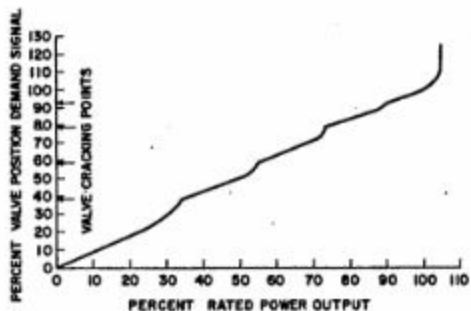

FIG. 7-6 CASE II - CURVE 1

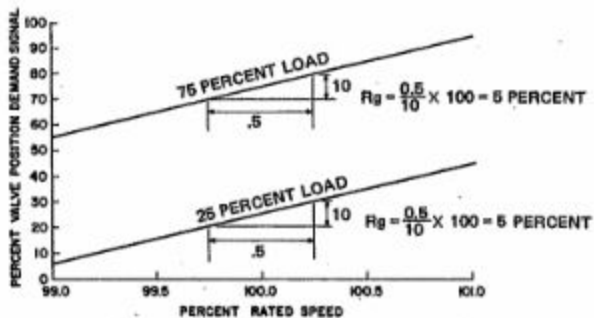

FIG. 7-7 CASE II - CURVE 2 - METHOD A

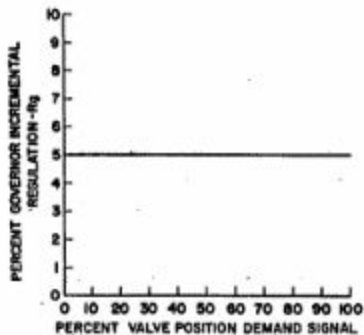

FIG. 7-8 CASE II - CURVE 2 - METHOD A

SPEED AND LOAD GOVERNING SYSTEMS FOR STEAM TURBINE-GENERATOR UNITS

TABLE 7-9 CASE II - CURVE 2 - METHOD B

Valve Position Demand Signal Inches (mm)	Speed/Load Changer Governing System References			
	25 percent	50 percent	75 percent	100 percent
	Speed r/min	Speed r/min	Speed r/min	Speed r/min
7.5 (190)	3395	3445	3488	3533
6.0 (152)	3463	3514	3555	3600
4.5 (114)	3519	3569	3609	3650
3.0 (76)	3566	3616	3654	3697
1.5 (38)	3607	3660	3694	3739
0.0	3643	3692	3728	3775
	Speed r/min	Speed r/min	Speed r/min	Speed r/min
	3564	3636	3683	3733
	3773	3812		

Percent* (Inches ÷ 6.0) (mm ÷ 152)	Percent* Rated Speed			
	Percent* Rated Speed	Percent* Rated Speed	Percent* Rated Speed	Percent* Rated Speed
125	94.3	95.7	96.9	98.1
100	96.2	97.6	98.8	100.0
75	97.8	99.1	100.3	101.4
50	99.1	100.4	101.5	102.7
25	100.2	101.7	102.6	103.9
0	101.2	102.6	103.6	104.9
	Percent* Rated Speed	Percent* Rated Speed	Percent* Rated Speed	Percent* Rated Speed
	99.0	101.0	102.3	103.7
	104.8	105.9		

Note: Percent rated speed = $\frac{r/\text{min}}{3600} \times 100$

Percent valve position demand signal = $\frac{\text{in.}}{6.0} \times 100$ or $\frac{\text{mm}}{152} \times 100$

ASME PERFORMANCE TEST CODES

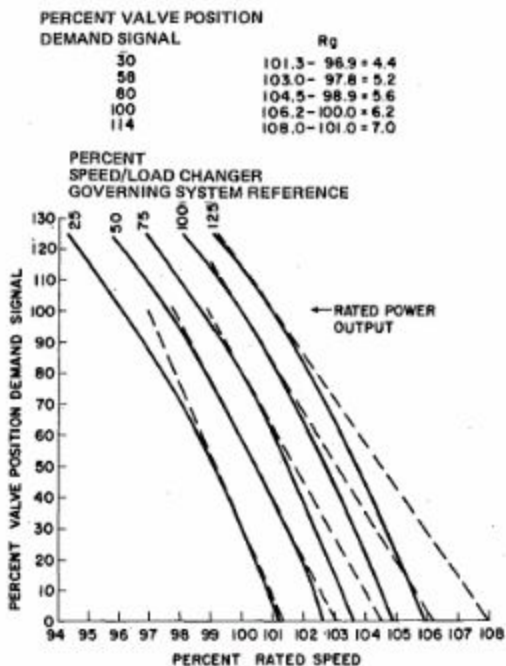

FIG. 7-10 CASE II - CURVE 2 - METHOD B

responding to 25, 50, 75 and 100 percent rated power output, from which percent valve position demand signal and percent speed/load changer governing system reference are calculated, as illustrated on Table 7-12.

With the unit generator main circuit breaker open and the speed/load changer governing system reference set at each of the speed/load changer governing system reference settings corresponding to 25, 50, 75 and 100 percent rated power output, as determined from Table 7-12 (above), determine

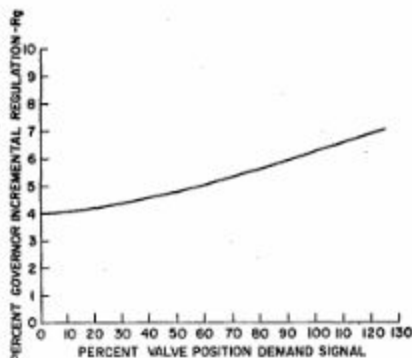

FIG. 7-11 CASE II - CURVE 2 - METHOD B

speed. Calculate percent rated speed for each setting, as shown in Table 7-13.

From the values in Table 7-12 and Table 7-13, percent valve position demand signal versus percent rated speed is plotted, as illustrated in Fig. 7-14; and then steady-state incremental speed regulation R_i is computed directly as illustrated.

- (e) Calculating steady-state incremental speed regulation from the curves:

- (1) Governor-controlled valve incremental factor - R_v : Using Curve 1 (Fig. 7-6) determine the ideal slope and the slope factor for various percent rated power outputs, as illustrated in Fig. 7-15 and tabulated in Table 7-16. Then compute the governor-controlled valve incremental factor R_v , as demonstrated in Table 7-16.
- (2) Steady-state incremental speed regulation - R_i : Under Case II, to compute steady-state incremental speed regulation Curve 1 (governor-controlled valve incremental factor R_v) is combined with Curve 2 (governor incremental

TABLE 7-12 CASE II - CURVE 2 - METHOD C

Percent Rated Power Output	Percent Speed/Load Changer Reference	Valve Position Demand Signal Inches (mm)	Percent Valve Position Demand Signal
100	100	6.0 (152.4)	100
75	80	4.8 (121.9)	80
50	50	3.0 (76.2)	50
25	22	1.3 (33.6)	22
0	0	0.0 (0.0)	0

ASME PTC*20.1 77 ■ 0759670 0052881 b ■

SPEED AND LOAD GOVERNING SYSTEMS FOR STEAM TURBINE-GENERATOR UNITS

TABLE 7-13 CASE II - CURVE 2 - METHOD C

Percent Speed/Load Changer Reference	Speed r/min	Percent Rated Speed
100	3747	104.1
80	3722	103.4
50	3679	102.2
22	3635	101.0
0	3600	100.0

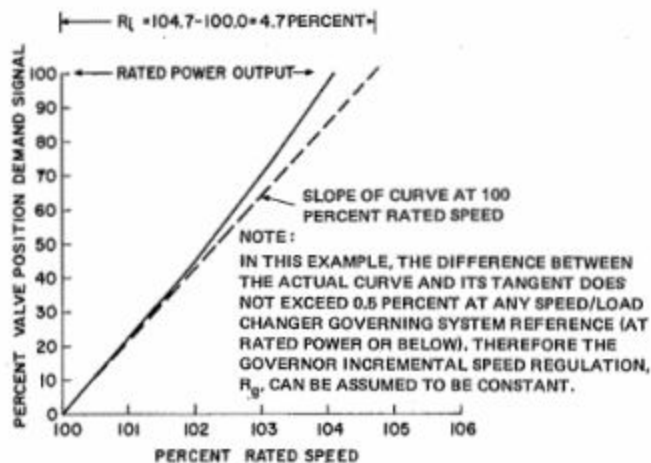

FIG. 7-14 CASE II - CURVE 2 - METHOD C

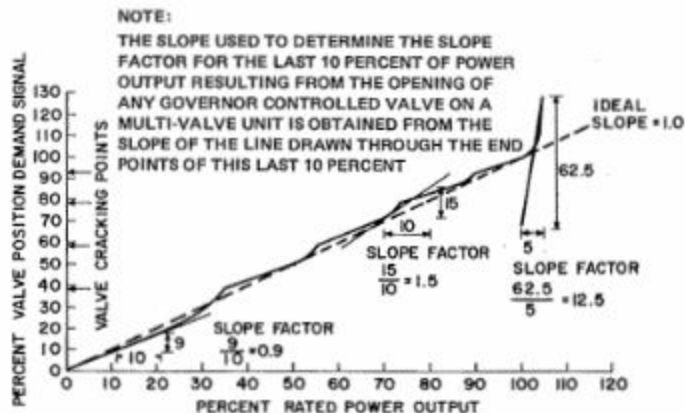

FIG. 7-15 CASE II

ASME PERFORMANCE TEST CODES

TABLE 7-16

Percent Rated Power Output (from Fig. 7-15)	Percent Valve Position Demand Signal (from Fig. 7-15)	Slope Factor (from Fig. 7-15)	Ideal Slope (from Fig. 7-15)	Governor-Controlled Valve Incremental Factor - R_v (Slope Factor \div Ideal Slope = R_v)
10.0	8.8	0.90	1.00	0.90
15.0	13.0	0.90	1.00	0.90
20.0	17.5	0.90	1.00	0.90
25.0	22.5	1.05	1.00	1.05
27.5	25.5	1.30	1.00	1.30
30.0	28.5	1.60	1.00	1.60
31.0	30.5	2.10*	1.00	2.10
34.5	37.5	2.10*	1.00	2.10
37.5	40.5	0.80	1.00	0.80
45.0	46.5	0.80	1.00	0.80
50.0	50.0	0.80	1.00	0.80
52.5	52.5	1.30	1.00	1.30
53.6	55.0	1.90*	1.00	1.90
55.7	59.5	1.90*	1.00	1.90
57.5	61.0	0.90	1.00	0.90
60.0	63.0	0.90	1.00	0.90
65.0	67.0	0.90	1.00	0.90
68.0	69.5	0.90	1.00	0.90
70.0	71.5	1.20	1.00	1.20
72.5	75.5	1.50	1.00	1.50
72.9	76.3	1.90*	1.00	1.90
73.8	79.0	1.90*	1.00	1.90
77.5	81.5	0.70	1.00	0.70
85.0	86.5	0.70	1.00	0.70
87.5	88.5	1.20	1.00	1.20
88.5	90.0	1.50*	1.00	1.50
90.0	92.5	1.50*	1.00	1.50
95.0	96.0	0.70	1.00	0.70
100.0	100.0	0.70	1.00	0.70
102.5	103.0	2.20	1.00	2.20
103.2	106.0	12.50*	1.00	12.50
104.7	125.0	12.50*	1.00	12.50

*These values lie within the range of the last 10 percent of power output of each governor-controlled valve. This is illustrated in Fig. 7-15 for the last valve to open.

ASME PTC*20.1 77 ■ 0759670 0052883 T ■

SPEED AND LOAD GOVERNING SYSTEMS FOR STEAM TURBINE-GENERATOR UNITS

TABLE 7-17 CASE II

Percent Valve Position Demand Signal	Governor-Controlled Valve Incremental Factor $-R_v$ (from Table 7-16)	Governor Incremental Regulation $-R_g$ (from Fig. 7-8)	Steady-State Incremental Speed Regulation ($R_i = R_v \times R_g$)
8.8	0.90	5.00	4.50
13.0	0.90	5.00	4.50
17.5	0.90	5.00	4.50
22.5	1.05	5.00	5.25
25.5	1.30	5.00	6.25
28.5	1.60	5.00	8.00
30.5	2.10	5.00	10.50
37.5	2.10	5.00	10.50
40.5	0.80	5.00	4.00
46.5	0.80	5.00	4.00
50.0	0.80	5.00	4.00
52.5	1.30	5.00	6.50
55.0	1.90	5.00	9.50
59.5	1.90	5.00	9.50
61.0	0.90	5.00	4.50
63.0	0.90	5.00	4.50
67.0	0.90	5.00	4.50
69.5	0.90	5.00	4.50
71.5	1.20	5.00	6.00
75.5	1.50	5.00	7.50
76.3	1.90	5.00	9.50
79.0	1.90	5.00	9.50
81.5	0.70	5.00	3.50
86.5	0.70	5.00	3.50
88.5	1.20	5.00	6.00
90.0	1.50	5.00	7.50
92.5	1.50	5.00	7.50
96.0	0.70	5.00	3.50
100.0	0.70	5.00	3.50
103.0	2.20	5.00	11.00
106.0	12.50	5.00	62.50
125.0	12.50	5.00	62.50

speed regulation R_g). For purposes of illustration Curve 2 Method A is used and for specific valve position demand signals R_g and R_v are tabulated in Table 7-17 and the steady-state incremental speed regulation R_i is computed. Figure 7-18 is the plot of steady-state incremental speed regulation versus percent rated power output.

7.15 Sample Calculation of Dead Band

7.15.1 The purpose of these sample calculations is to give a specific example of the determination of dead band with the data recorded under Par. 4.15 using the method of calculation described in Par. 5.15.

7.15.2 (a) Method A

From chart shown in Fig. 7-19 the ΔN is

ASME PERFORMANCE TEST CODES

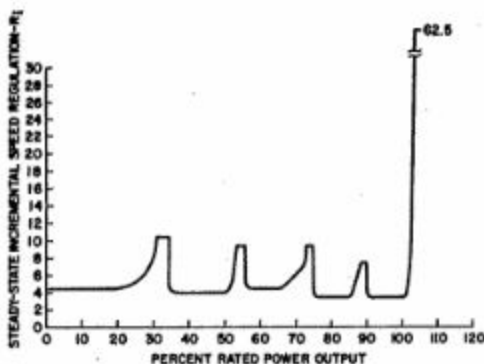

FIG. 7-18 CASE II

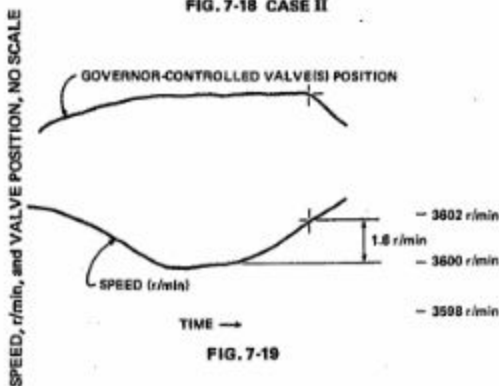

FIG. 7-19

established as 1.8 r/min while the rated speed (N_r) is 3600 r/min.

$$N_d = \frac{1.8}{3600} \times 100 = 0.05 \text{ percent}$$

(b) Method B

The speed/load changer governing system reference calibration (C_i) is 0.2 r/min/division (Fig. 7-20).

The change in speed/load changer governing system reference required to record a change in the governor-controlled valve(s) position (δN_i) is 9.0 divisions (Fig. 7-21).

The rated speed (N_r) is 3600 r/min.

$$N_d = \frac{C_i \times \delta N_i}{N_r} \times 100$$

Example:

$$N_d = \frac{0.2 \times 9.0}{3600} \times 100 = 0.05 \text{ percent}$$

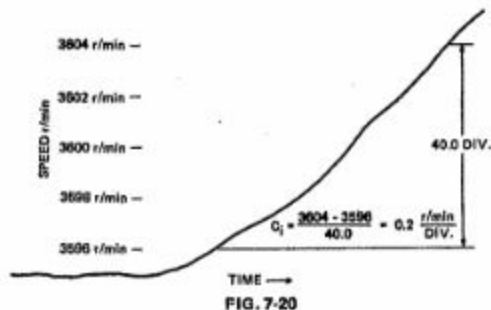

FIG. 7-20

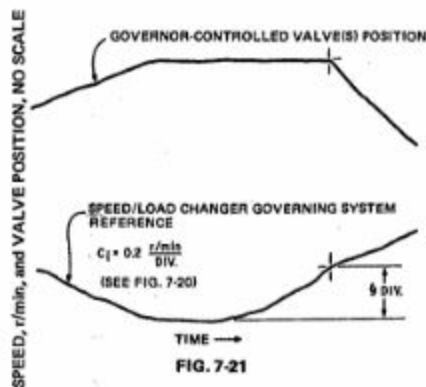

FIG. 7-21

7.16 Sample Calculation of Steady-State Governing Speed Band

7.16.1 The purpose of these sample calculations is to give a specific example of the determination of steady-state governing speed band with the data recorded under Par. 4.16 using the methods of calculation described in Par. 5.16.

7.16.2 (a) Method A

From the charts shown in Fig. 7-22 the peak-to-peak amplitudes of the speed oscillations found under Par. 4.16.4(a) and Par. 4.16.4(c), respectively, are 3.8 and 2.0 r/min while the rated speed (N_r) is 3600 r/min.

$$\Delta N_B = \frac{3.8 - 2.0}{3600} \times 100 = 0.05 \text{ percent}$$

(b) Method B

From the chart shown in Fig. 7-23 the peak-to-peak amplitudes of speed oscillations found

SPEED AND LOAD GOVERNING SYSTEMS FOR STEAM TURBINE-GENERATOR UNITS

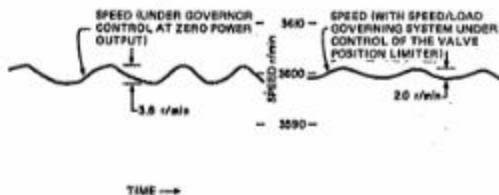

FIG. 7-22

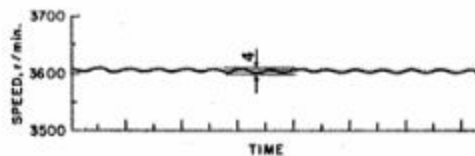

FIG. 7-25

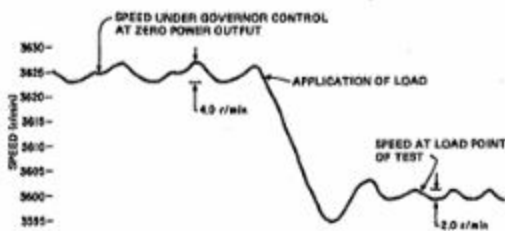

FIG. 7-23

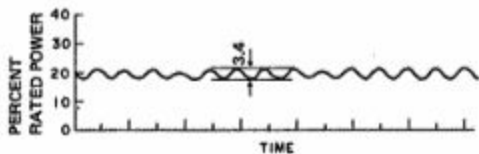

FIG. 7-26

4.17 using the method of calculation described in Par. 5.17.

7.17.2 (a) Method A

From the chart shown in Fig. 7-24 the peak-to-peak amplitude of the load oscillations found under Par. 4.17.4(a) and Par. 4.17.4(b), respectively, are 350 and 150 kW while the rated power output is 100,000 kW.

$$\Delta P_B = \frac{350 - 150}{100,000} \times 100 = 0.20 \text{ percent}$$

(b) Method B

- (1) From Fig. 7-25, valve limited, speed variation is 4.0 r/min.
- (2) From Fig. 7-18 incremental speed regulation at test power point of 19.3 percent is 4.5 percent.
- (3) From Fig. 7-26 test point power variation is 3.4 percent.

$$\Delta P_B = 3.4 - \left(\frac{4.0 \times 100}{3600} \times 100 \right) = 0.93 \text{ percent}$$

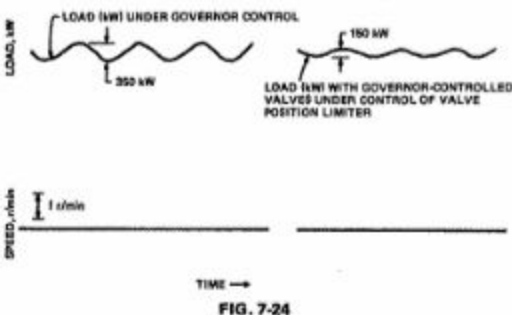

FIG. 7-24

under Par. 4.16.4(a) and Par. 4.16.4(c), respectively, are 4.0 and 2.0 r/min while the rated speed (N_r) is 3600 r/min.

$$\Delta N_B = \frac{4.0 - 2.0}{3600} \times 100 = 0.055 \text{ percent}$$

7.17 Sample Calculation of Steady-State Governing Load Band

7.17.1 The purpose of these sample calculations is to give a specific example of the determination of steady-state governing load band with the data recorded under Par.

7.20 Illustrative Diagrams, Including Descriptions of MH and EH Governing Systems

7.21 Typical Governor Systems

7.21.1 In a typical mechanical-hydraulic governor, the functions necessary to provide control of the steam flow to the turbine are performed by mechanical and/or hydraulic devices. Input/output signals are expressed in terms of lever/rod/valve positions and hydraulic pressures. A typical electro-hydraulic governor combines

ASME PERFORMANCE TEST CODES.

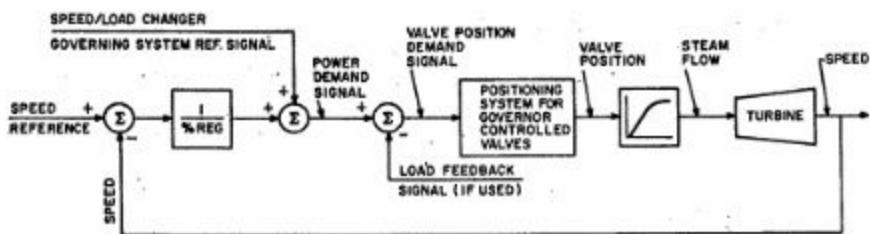

FIG. 7-27 TYPICAL ELECTRO-HYDRAULIC (EH) SYSTEM

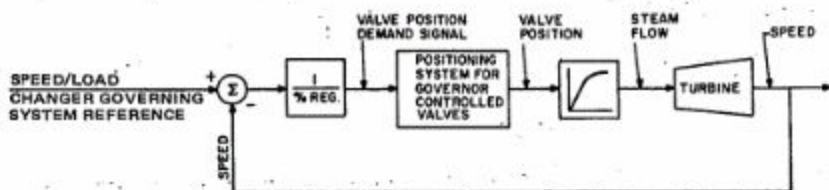

FIG. 7-28 TYPICAL MECHANICAL-HYDRAULIC (MH) SYSTEM

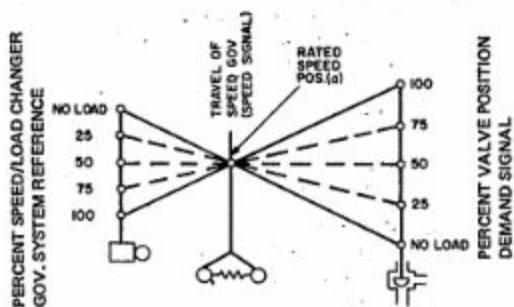

FIG. 7-29

electrical devices and circuits with mechanical and hydraulic devices to provide the desired control. Input/output signals can be expressed in terms of voltages or current flows in addition to mechanical positions/hydraulic pressures. The electrical components may use analog or digital signals.

7.22.1 Figure 7-29 illustrates schematically a speed/load governing system in which speed is not changed with power output. It can be seen in the mechanical-hydraulic system that the lever system pivots about the speed governor position (speed signal) (a) and there are corresponding positions of the speed/load changer governing system reference and the valve position demand signal as long as the speed is constant. In this illustration, speed is shown at rated speed, N_r . In addition, the speed error

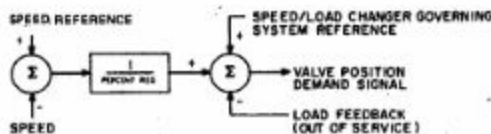

FIG. 7-30

remains constant, and the speed/load changer governing system reference is varied from 0 to 100 percent to obtain full range of the valve position demand signal.

This figure illustrates the procedure specified in Par. 4.14.4.2(b), Method C. The valve position demand signals marked 25, 50, 75 and 100 percent are determined for the correspondingly marked positions of the speed/load changer governing system reference.

Figure 7-30 illustrates the same rationale of Fig. 7-29 for an electro-hydraulic system in that at constant speed there will be a corresponding value of valve position demand signal for each value of speed/load changer governing system reference.

Figure 7-31 also illustrates the procedure specified in Par. 4.14.4.2(b), Method C. At no load, the speed/load changer governing system reference setting (25, 50, 75 and 100 percent); in Fig. 7-29 are set in and the corresponding turbine speeds (signals) are determined.

The same information can be obtained in an electro-hydraulic system by varying the setting of the speed/load changer governing system reference from no load to 100 percent with the generator main circuit breaker open,

SPEED AND LOAD GOVERNING SYSTEMS FOR STEAM TURBINE-GENERATOR UNITS

and noting the speed at values of the speed/load changer governing system reference corresponding to loads of 25, 50, 75 and 100 percent.

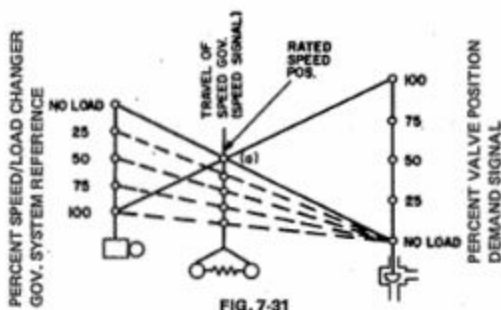

FIG. 7-31

7.22.2 Figure 7-32 illustrates the procedure specified in Par. 4.14.4.2(b), Method B. With the speed/load changer governing system reference set at a point corresponding

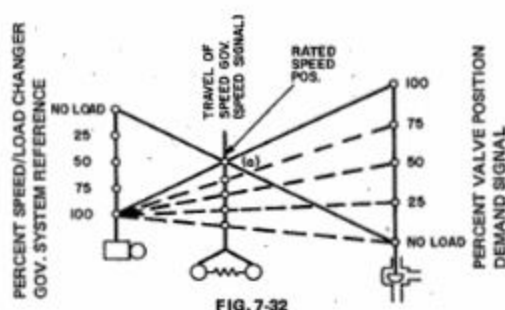

FIG. 7-32

TABLE 7-33 RECOMMENDED TEST MEASUREMENT

NOTE:

REFER TO PAR 4.10.4 FOR PLANT OPERATING CONDITIONS TO BE RECORDED FOR ALL TESTS.

	SPEED RECORDER 0-115 PERCENT	SPEED RECORDER 85-115 PERCENT	SPEED RECORDER (99-101 PERCENT)	UNIT POWER RECORDER	SYSTEM OR TEST LOAD POWER RECORDER	SPEED / LOAD CHANGER GOV. REFERENCE RECORDER	GOVERNOR-CONTROLLED VALVE POSITION RECORDER	VALVE POSITION DEMAND SIGNAL RECORDER	ACCELERATION RATE SETTING	HIGH SPEED LIMIT SETTING	LOW SPEED LIMIT SETTING	THROTTLE/STOP VALVE POSITION INDICATORS	VALVE POSITION SETTLING INDICATOR	ALL VALVE RECOMMENDED BY THE MANUFACTURER TURBINE RECORDERS	GENERATOR BREAKER STATUS-RECORDER
MINIMUM SPEED HOLDING LEVEL 4.12.4	X					X			X						
OTHER SPEED HOLDING LEVELS 4.12.5	X					X			X						
SPEED/LOAD CHANGER LOW SPEED LIMIT 4.12.7		X				X					X				
SPEED/LOAD CHANGER HIGH SPEED LIMIT 4.12.8		X				X				X					
MAXIMUM SPEED AT RATED POWER 4.12.10		X				X	X			X		X			
STEADY-STATE SPEED REGULATION 4.13	X	X	X	X		X		X							
STEADY-STATE INCRE- MENTAL SPEED REG. 4.14		X	X	X		X		X					X		
DEAD BAND 4.15			X	X		X	X								
STEADY-STATE GOVERNING SPEED BAND 4.16			X	X									X		
STEADY-STATE GOVERNING LOAD BAND 4.17			X	X									X		
RESPONSE AND SETTLING TIME 4.18			X	X	X	X	X								
OVERSPEED 4.19	X			X			X							X	X
GOVERNING SYSTEM REFERENCE REDUCING TIME 4.20						X									

ASME PERFORMANCE TEST CODES

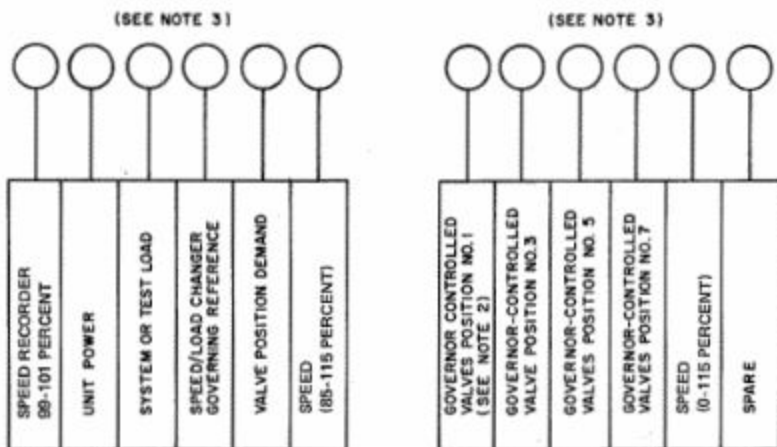

NOTES

1. EACH RECORDER TO BE PROVIDED WITH AN EVENT MARKER OPERATED BY THE STATUS OF THE GENERATOR BREAKERS.
2. ASSUMES 8 VALVE MACHINE WITH VALVES OPERATED IN PAIRS.
3. CIRCLES REPRESENT TRANSMITTERS, RANGING AMPLIFIER AND SIGNAL CONDITIONING REQUIRED FOR EACH RECORDER INPUT.

FIG. 7-34 TYPICAL INSTRUMENTATION DIAGRAM

to 100 percent power output, steam is admitted in a manner to control turbine speed independently of the governor-controlled valves. The turbine speeds are then determined for valve position demand signals corresponding to 25, 50, 75 and 100 percent load. This is repeated for each speed/load changer governing system reference corresponding to 75, 50 and 25 percent load. It is obvious that these speeds will correspond to those determined, as illustrated in Par. 7.22.1.

7.30 Instrumentation Diagrams

7.30.1 Table 7-33, "Recommended Test Measurements," lists the test measurements required when performing a test. The measurements listed in the table are used in determining or calculating test results. Refer to Par. 4.10.4 for plant operating conditions to be recorded for all tests.

7.30.2 Figure 7-34, "Typical Instrumentation Diagram," is a suggested arrangement of the test equipment and sensors required to perform the tests listed in Table 7-33 above. Test equipment should include sensors, signal conditioning devices and recorders. Each recorder channel shall be capable of zero and span adjustment. Strip chart recorders should include a marking pen operated from an external contact closure.

7.40 Indirect Test Methods

7.41 Performance Testing Philosophy. The ASME Performance Test Codes specify procedures for determination of actual equipment performance and confirmation of performance guarantees. For these purposes complete and direct testing of the specified equipment is required. While partial and indirect tests cannot replace those described in the Code, such tests do play an important role in preparation for Code tests. This is particularly true of control system equipment where calibrations and tuning adjustments are a significant factor in establishing the quality of the equipment's performance. Hence, this section is included to give some general guidance in the use of indirect test methods.

7.42 Types of Indirect Tests. Two basic types of indirect testing can be used: partial and simulation.

7.42.1 Partial Tests. Partial tests can be run where tests are limited in scope, magnitude, or equipment operating conditions. Verification of proper equipment operation by running several preliminary tests selected from the Code is an example of scope-limited partial tests. Load rejection from part load prior to a test of load rejection from full load is an example of a magnitude-limited partial test. Obtaining equipment performance at a

SPEED AND LOAD GOVERNING SYSTEMS FOR STEAM TURBINE-GENERATOR UNITS

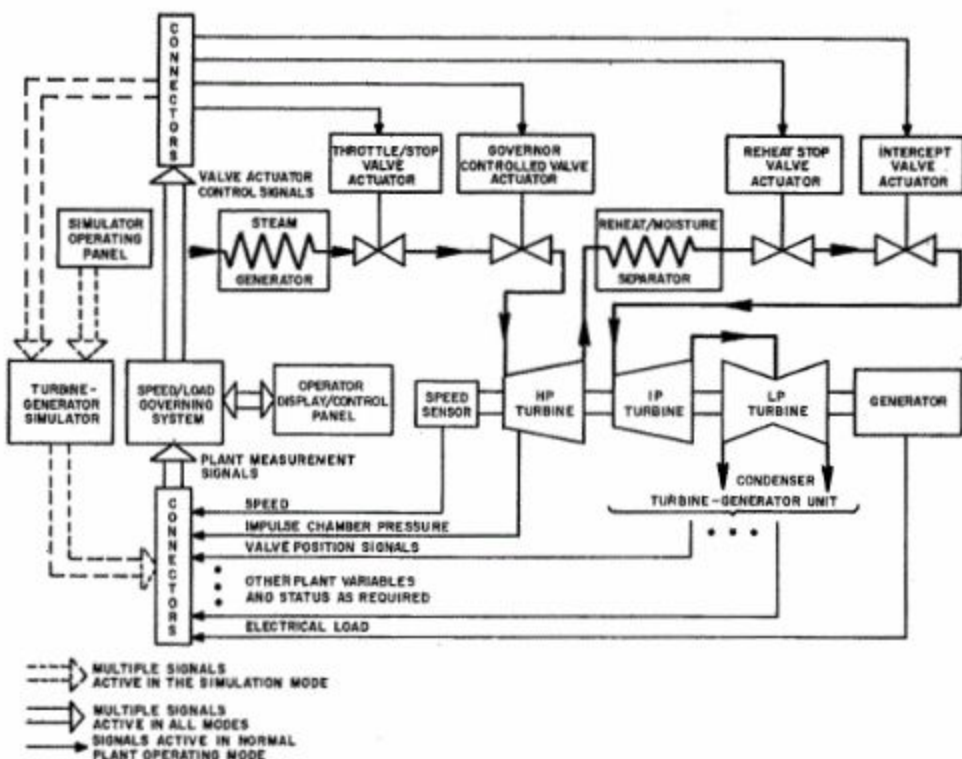

FIG. 7-35 TYPICAL SIMULATION TEST BLOCK DIAGRAM

single operating condition is an example of operating condition limited testing. Plans for partial testing should be accompanied by a rationale and method of extrapolating the measured results to the probable results when the complete set of tests is run.

7.42.2 Simulation Testing. A wide range of simulation tests is possible depending on the equipment replaced by simulation and the level of equipment characteristics represented in the simulation. Important data on speed/load governing system performance can be obtained by testing the actual control mechanism against a simulation of the turbines, including all associated valves and steam supplies. These tests can be performed in the factory prior to shipment or in the field after installation of the system. This form of simulation is valuable for pre-operation equipment debugging, line-up, calibrating and tuning. The simulator used for this function is also a valuable tool for periodic equipment maintenance.

7.42.2.1 Simulator Application. Simulators are approximations of real equipment. Thus, accuracy criteria and bases for measurement of simulator quality are required to judge its adequacy. Typically, actual open-loop response data of the simulated or similar equipment form the bases for accuracy comparisons. All input and output variables of interest from interconnected equipment must be provided by the simulation. In the case of a speed governing control system, a turbine-generator speed and a means for controlling steam flow to the turbine are minimum requirements. More sophisticated governors will require means for closing valve position, speed, load, and pressure control loops. Simulators for performing these functions are commercially available. A typical simulator test block diagram is shown in Fig. 7.35.

7.43 Expected Results. Simulation, in the context of the ASME Performance Test Codes, must be viewed

ASME PTC*20.1 ?? ■ 0759670 0052890 7 ■

ASME PERFORMANCE TEST CODES

as an intermediate step to final confirmation of equipment performance. Thus, simulation is a tool for preliminary equipment checkout, set-up, line-up, maintenance, problem diagnosis, and personnel training. It is expected that judicious use of preliminary indirect testing will result in: (1) verification that the equipment and instrumentation are operating correctly, (2) preliminary equipment calibrations and tuning for optimum performance, and (3) expeditious and accurate testing.

7.50 Step-to-Ramp Transform. In some cases a step response test cannot be performed due to operating limitations and/or equipment design. A ramp response test can then be substituted and response criteria must be agreed upon by the parties concerned. The results from the ramp response can be converted into an equivalent step response.

PERFORMANCE TEST CODES

While providing for exhaustive tests, these Codes are so drawn that selected parts may be used for tests of limited scope.

A specially designed binder for holding these pamphlets is available.

A complete list of ASME publications will be furnished upon request.

PERFORMANCE TEST CODES NOW AVAILABLE

PTC 4.3 — Air Heaters	(1968)
PTC 23 — Atmospheric Water Cooling Equipment	(1958)
PTC 8.2 — Centrifugal Pumps	(1965)
PTC 4.2 — Coal Pulverizers	(1969)
PTC 10 — Compressor and Exhausters	(1965)
PTC 2 — Definitions and Values	(1971)
PTC 9 — Displacement Compressors, Vacuum Pumps and Blowers	(1970)
PTC 7.1 — Displacement Pumps	(1962)
PTC 12.3 — Deserators	(1958)
PTC 27 — Determining Dust Concentration in a Gas Stream	(1957)
PTC 28 — Determining the Properties of Fine Particulate Matter	(1965)
PTC 3.1 — Diesel and Burner Fuels	(1958)
PTC 21 — Dust Separating Apparatus	(1941)
PTC 24 — Ejectors	(1976)
PTC 14 — Evaporating Apparatus	(1970)
PTC 12.1 — Feedwater Heaters	(1955)
PTC 16 — Gas Producers and Continuous Gas Generators	(1958)
PTC 22 — Gas Turbine Power Plants	(1966)
PTC 3.3 — Gaseous Fuels	(1969)
PTC 1 — General Instructions	(1970)
PTC 18 — Hydraulic Prime Movers	(1949)
PTC 31 — Ion Exchange Equipment	(1973)
PTC 32.1 — Nuclear Steam Supply Systems	(1969)
PTC 20.2 — Overspeed Trip Systems for Steam Turbine-Generator Units	(1965)
PTC 20.3 — Pressure Control Systems Used on Steam Turbine-Generator Units	(1970)
PTC 17 — Reciprocating Internal-Combustion Engines	(1973)
PTC 7 — Reciprocating Steam-Driven Displacement Pumps	(1949)
PTC 5 — Reciprocating Steam Engines	(1949)
PTC 25.3 — Safety and Relief Valves	(1976)
PTC 3.2 — Solid Fuels	(1954)
PTC 20.1 — Speed and Load Governing Systems for Steam Turbine-Generator Units	(1977)
PTC 29 — Speed-Governing Systems for Hydraulic Turbine-Generator Units	(1965)
PTC 26 — Speed-Governing Systems for Internal Combustion Engine-Generator Units	(1962)
PTC 12.2 — Steam Condensing Apparatus	(1955)
PTC 4.1 — Steam-Generating Units	(1964)
PTC 6 — Steam Turbines	(1976)
PTC 6A — Appendix A to Test Code for Steam Turbines	(1964)
PTC 6 Report — Guidance for Evaluation of Measurement Uncertainty in Performance Tests of Steam Turbines	(1969)
PTC 6S Report — Simplified Procedures for Routine Performance Tests of Steam Turbines	(1970)

C 00019