

Description

The PTC000X-01 modular Jack has been specifically designed for implementation of fast Ethernet NIC Application . These modular consist of the isolation transformer. Common mode choke, termination resistors and high voltage capacitor termination to the shield. With high voltage isolation, optimized rise time, wide bandwidth and stable inductance, the transformer integrated the module provide excellent performance as an analog interface. Common mode choke have been designed to significantly reduce common mode noise level which may contribute EMI emission. PTC000X-01 modular jack provide the system designer the opportunity of reducing pcb space.

Feature

- ◆ Designed for network interface card application.
- ◆ Designed to meet IEEE802.3u requirement.
- ◆ Available in all turn ratios used by LAN IC manufactures.
- ◆ Primary center taps available for additional EMI reduction.
- ◆ Simplest magnetic component to place and route on PCB.
- ◆ Contains termination resistors , magnetic and connector.
- ◆ Conserves PCB space.

Specifications

Parameter	Condition	Min.	Max	unit
Inductance,	*note1	350		μH
Insertion loss	@1-100MHz		1.0	dB
Return loss	@1-30MHz	16		dB
	@30-60MHz *note2			dB
	@60-80MHz	10		dB
Cross talk	@1-60MHz	40		dB
	@60-100MHz	38		dB
CMRR(TX/RX)	@1-60MHz	45/40		dB
	@60-100MHz	40/35		dB
Voltage isolation		1500		vrms
Operating temp.		0	70	°C

Turn Ratio

Part No.:	TX	RX
PTC0001-01	1CT : 1CT	1CT : 1CT
PTC0002-01	1.414CT : 1CT	1CT : 1CT
PTC0003-01	2CT : 1CT	1CT : 1CT
PTC0004-01	1.25CT : 1CT	1CT : 1CT
PTC0006-01	1CT : 1.414CT	1CT : 1CT
PTC0007-01	1CT : 1.25CT	1CT : 1CT
PTC0008-01	1CT : 2CT	1CT : 1CT

Note 1 : measured at 8mAdc over operating temperature 0-70°C

Note 2: Greater than (16-20 log(f/30 MHz)) dB

Schematic

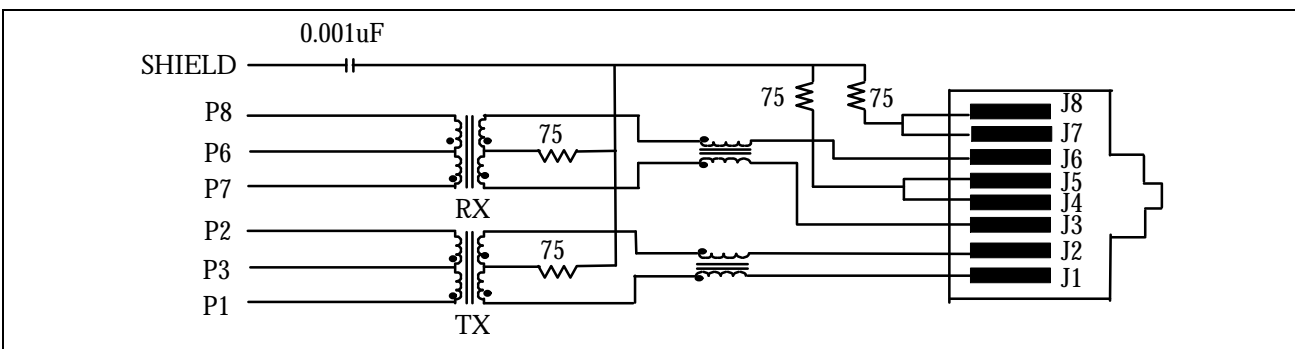

Test Requirements and Procedures

No	Item	Requirement	Test or Inspection Method
1	Examination of product.	Meet requirements of product drawing	Visual, dimensional and functional per applicable inspection plan.
2	Solderability	Max. 5% de-wetting, inspection with 10 times magnification.	Inspect surface of soldering legs visually, after soldering samples mounted on a printed circuit board. Solderbath: 235°C Duration: 2 seconds. Ref: IEC 68-2-20, Ta method 1.
3	Resistance to soldering heat.	No functional damage.	Inspect Jack visually after soldering samples on a printed circuit board. Solderbath: 260°C Duration: 5 seconds. Ref. IEC 68-2-20, test Tb method 1A.
4	Contact resistance	contact resistance 10 milliohms max per initial contact resistance (ΔR 30 milliohms max. For Tool-LESS)	Subject mated Plug and Jack to 20mV open circuit at 10 mA maximum. See fig. 3. Ref: IEC 512-2, test 2a.
5	Dielectric withstanding voltage.	1500 Vac RMS dielectric withstanding voltage.	Subject adjacent contacts of mated plug and jack to the specified voltage . Ref: IEC 512-2, test 4a. method B.
6	Insulation Resistance.	500 Megohms minimum.	Subject adjacent contacts of mated plug and jack to the specified voltage: 500Vdc . Ref. IEC 512-2, test 3a. method B.

Test Requirements and Procedures

NO	ITEM	Requirement	Test or inspection Method
7	Printed circuit board retention	Module Jack should not dislodge from p.c.b	Apply load of 20 LBS to modular Jack which is mounted on a printed circuit board of 1.6mm thickness, at a rate of 25mm per minute.
8	Plug retention in Jack.	Plug shall not dislodge from Jack and shall maintain electrical continuity.	Apply axial Load of 20 LBS to modular plug which is mated to a modular Jack at a rate of 25mm per minute.
9	Vibration.	No discontinuities and show no evidence of physical damage.	Subject Modular Jack and Modular Plug to sinusoidal vibration along each of 3 mutually perpendicular axes. 10 Cycles at a Level of 50m/s ² from 10-500Hz at a rate of 1 octave/minute. (Duration approx. 3 x 2 hours) Ref: IEC 68-2-6, test Fc.
10	Durability.	Contact resistance ,plug Retention and pcb retention shall meet each specified requirement	Mate and unmate Plug and Jack For 500 cycles total at a maximum rate of 500 cycles/hour. Ref: IEC 512-5, test 9a.
11	Insertion force	Insertion force should not exceed 5 pounds	Measure force necessary to mate Plug and Jack at a rate of 25mm per minute Ref:IEC512-7, test 13b.
12	Thermal shock.	Contact resistance, Insulation resistance shall meet each specified requirement .	Subject mated Plug and Jack to 25 cycles between -40°C and 70°C. The duration at the extreme temperature shall be 30 minutes. Ref: IEC 58-2-14, test N.
13	Temperature-humidity cycling.	Contact resistance, Insulation resistance shall meet each specified requirement .	Subject mated plug and Jack to 10 temperature – humidity cycles between 25°C and 55°C at 95% RH. Ref.: IEC 68-2-30, test Db.

Test Setup : Insertion Loss Measurement

The insertion loss of a device connected into a given Transmission system is defined as the ration of power (before and after insertion) delivered to the output network beyond the point of insertion at a given frequency.

Fig1 illustrate the test circuit configuration for insertion loss measurement. To perform the insertion loss test ,thru calibration must be done prior the measuring while the network Analyzer being selected in S21 mode.

A matching balun must be used to convert the 50ohms of output impedance of test instrument into the primary input impedance of the device under test.

Without this matching balun, impedance mismatch between the test instrument and the device causes measurement error.

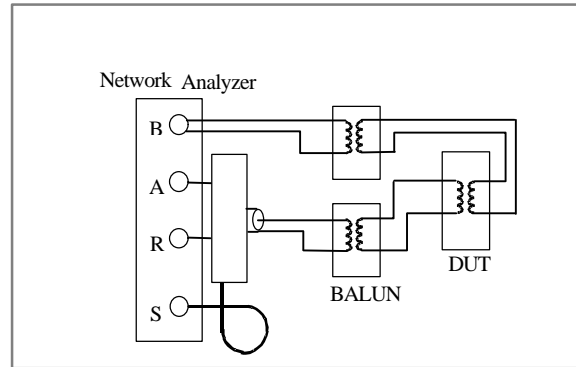

Fig1

Return loss measurement

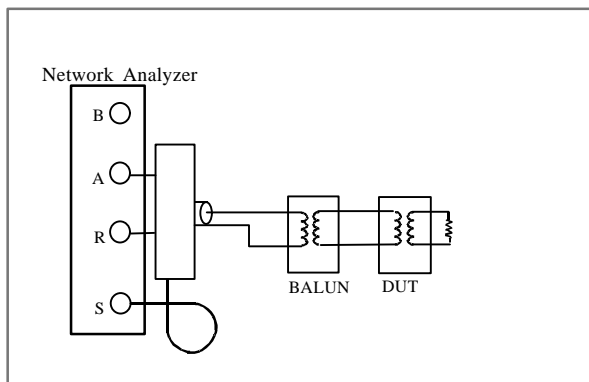

Fig2

Return loss measure the amount of energy that is lost due to Reflection.

Reflected energy occur because of impedance mismatching these energy will reduce the overall system efficiency and emanate nuisance noise.

Fig2 illustrate the test configuration for return loss measurement

To perform the return loss test ,open ,short, load calibration must be done prior to measuring while the network analyzer being selected in S11 mode.

Two matching baluns with appropriate output impedance must be used to match the impedance of the transformer under test as shown in the figure 2.

Cross talk measurement

Cross Talk can be measured with setup shown in Fig 3 by applying signal of identical information to the transmitter channel and detecting the coupling signal level at receive channel.

Through calibration before measurement should be done.

Both of transmitter and receiver channel should be terminated with proper load while measuring.

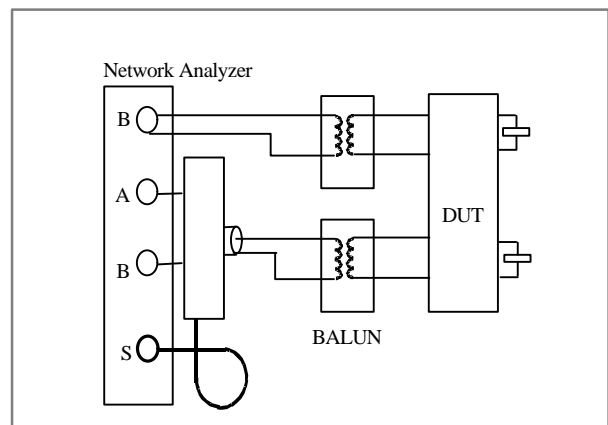
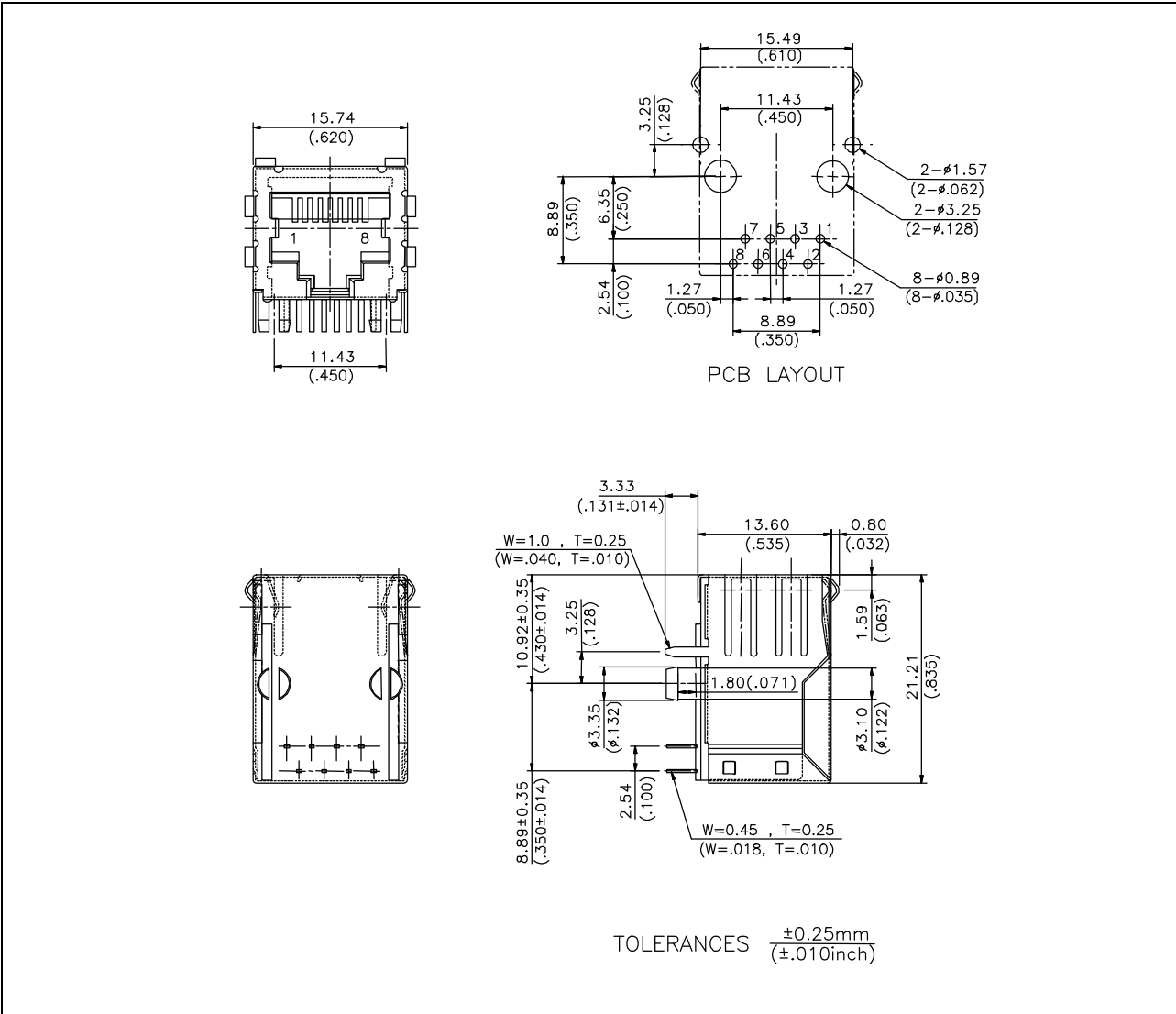

Fig3

Dimension:



- ◆ Shield 0.25mm Thickness C5191 with Nickel Plated
- ◆ Housing.....Standard Material PBT , Glass Filled Polyester UL94V-0
Standard Color Black
- ◆ Contact Pin.....Plastic : NyLon-46 Glass Filled , UL94V-0 , Standard Color Black
Pin : Phosphor Bronze Wire t0.35*w0.45
Plating : Phosphor Bronze Gold Plating Over Nickel