

PTF180901

GSM/EDGE RF Power FET

The PTF180901

One of our new line of GSM/EDGE/CDMA2000 devices, the PTF180901 is optimized for the DCS and PCS bands. This device operates at 47% efficiency with 13.5 dB of gain and produces 115 W, P_{-1dB} . This high-gain high-efficiency device is ideal to power your amplifier design. A laterally diffused single-ended GOLDMOS[®] FET, it incorporates full gold metallization and integrated ESD protection to ensure excellent lifetime and reliability.

Features

- Optimized for bandwidths 1805 MHz – 1880 MHz and 1930 MHz – 1990 MHz
- Improved ruggedness
- Broadband internal matching
- Full gold metallization
- Integrated ESD protection: Human Body Model, Class 1 (minimum)
- Excellent thermal stability
- Low HCl drift
- Capable of handling 10:1 VSWR @ 28 V, 90 W (CW) output power

Performance

- Typical EDGE performance
 - Average output power = 35 W
 - Gain = 14.5 dB
 - Efficiency = 32%
 - EVM = 1.7% AVG
 - ACPR @ 400 KHz = -60 dBc
 - ACPR @ 600 KHz = -74 dBc
- Typical two-tone performance
 - Output power = 90 W PEP
 - Gain = 15 dB
 - Efficiency = 36%
 - IM₃ = -30 dBc
 - 1 MHz tone spacing

Type List

Type	Output Power	Gain	Supply Voltage	Package Type	Package
PTF180901E	90 W	15 dB	28 V	Thermally enhanced	30248
PTF180901F	90 W	15 dB	28 V	Thermally enhanced, earless	31248

www.infineon.com/wireless

Wireless Communication



Never stop thinking.

Performance Characteristics

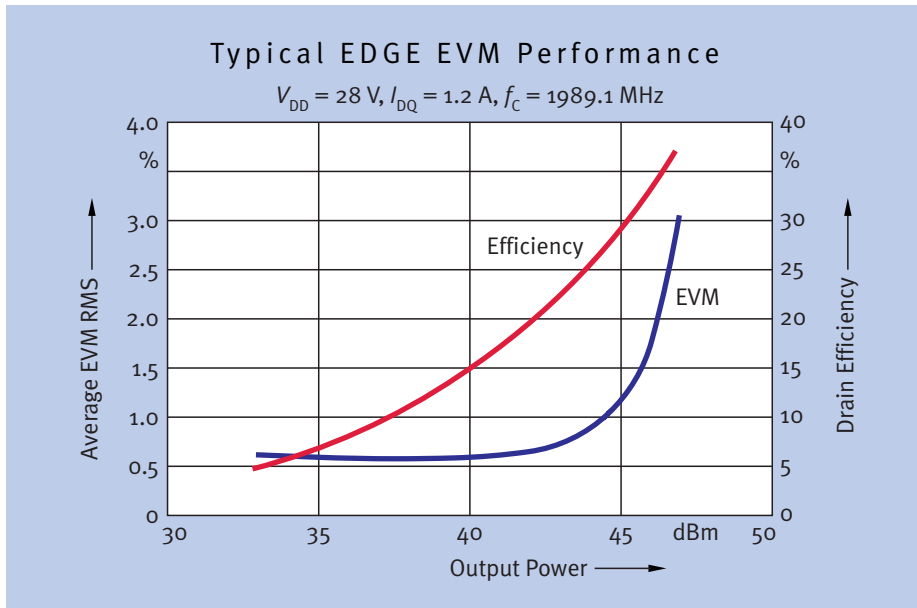

Two-Tone Measurements

$V_{DD} = 28\text{ V}, I_{DQ} = 1.2\text{ A}, P_{OUT} = 90\text{ W PEP}, f_c = 1930\text{ MHz}, \text{ Tone Spacing} = 100\text{ kHz}$

Characteristic	Symbol	Min.	Typ.	Max.	Units
Gain	G_{ps}	14	15	-	dB
Drain Efficiency	η_D	30	36	-	%
Intermodulation Distortion	IMD	-	-30	-28	dBc

Application Example

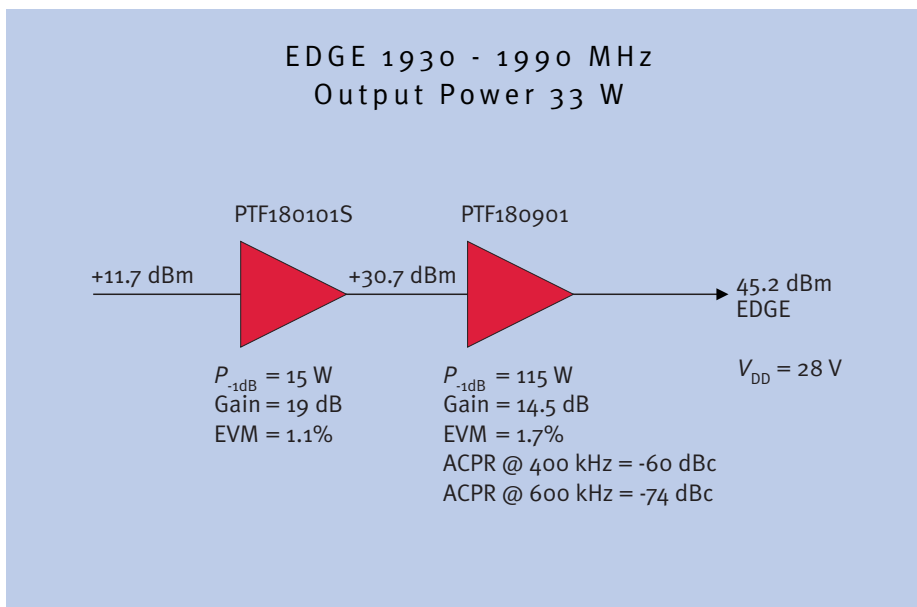

How to reach us:
<http://www.infineon.com>

Published by
Infineon Technologies AG,
 St.-Martin-Strasse 53,
 D-81669 München

© Infineon Technologies AG 2004.
 All Rights Reserved.

Template: pb_tmplt.fm/4/2004-01-01

Attention please!

The information herein is given to describe certain components and shall not be considered as a guarantee of characteristics. Terms of delivery and rights to technical change reserved.

We hereby disclaim any and all warranties, including but not limited to warranties of non-infringement, regarding circuits, descriptions and charts stated herein.

Information

For further information on technology, delivery terms and conditions and prices please contact your nearest Infineon Technologies Office.

Warnings

Due to technical requirements components may contain dangerous substances. For information on the types in question please contact your nearest Infineon Technologies Office.

Infineon Technologies Components may only be used in life-support devices or systems with the express written approval of Infineon Technologies, if a failure of such components can reasonably be expected to cause the failure of that life-support device or system, or to affect the safety or effectiveness of that device or system. Life support devices or systems are intended to be implanted in the human body, or to support and/or maintain and sustain and/or protect human life. If they fail, it is reasonable to assume that the health of the user or other persons may be endangered.