

## Thermally-Enhanced High Power RF LDMOS FETs 240 W, 1930 – 1990 MHz

### Description

The PTFB192503EL and PTFB192503FL are 240-watt LDMOS FETs intended for use in multi-standard cellular power amplifier applications in the 1930 to 1990 MHz frequency band. Features include input and output matching, high gain, wide signal bandwidth and reduced memory effects for improved DPD correctability. Manufactured with Infineon's advanced LDMOS process, these devices provide excellent thermal performance and superior reliability.

PTFB192503EL  
Package H-33288-6



PTFB192503FL  
Package H-34288-4/2

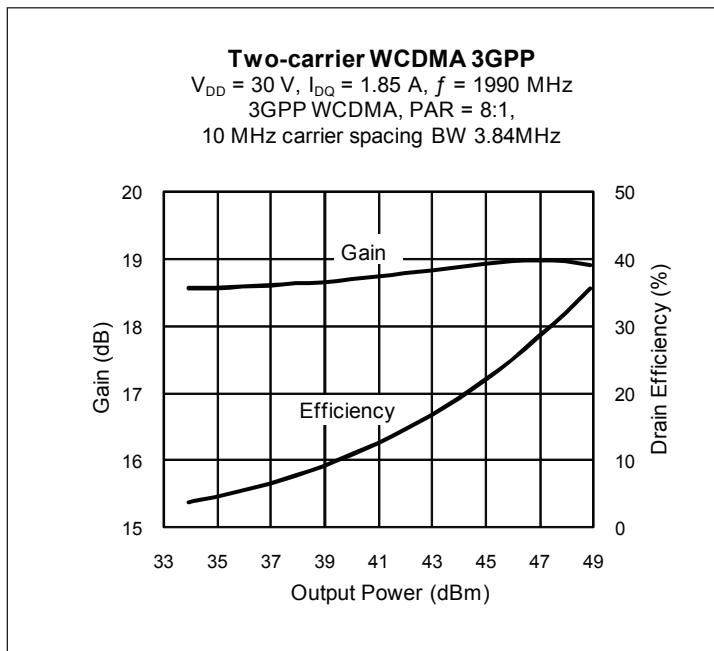

### Features

- Broadband internal input and output matching
- Enhanced for use in DPD error correction systems
- Typical two-carrier WCDMA performance, 30 V, 1990 MHz
  - Average output power = 50 W
  - Linear gain = 19 dB
  - Drain efficiency = 28 %
  - Intermodulation distortion = -35 dBc
- Typical CW performance, 1990 MHz, 30 V
  - Output power at  $P_{1dB}$  = 240 W
  - Efficiency = 55%
- Increased negative gate-source voltage range for improved performance in Doherty peaking amplifiers
- Integrated ESD protection. Human Body Model, Class 2 (minimum)
- Capable of handling 10:1 VSWR @ 30 V, 240 W (CW) output power
- Pb-free, RoHS-compliant

### RF Characteristics

**Two-carrier WCDMA Measurements** (not subject to production test—verified by design/characterization in Infineon test fixture)

$V_{DD} = 30\text{ V}$ ,  $I_{DQ} = 1.9\text{ A}$ ,  $P_{OUT} = 50\text{ W}$  average,  $f_1 = 1980\text{ MHz}$ ,  $f_2 = 1990\text{ MHz}$ , 3GPP signal, channel bandwidth = 3.84 MHz, peak/average = 8:1 dB @ 0.01% CCDF

Characteristic	Symbol	Min	Typ	Max	Unit
Gain	$G_{ps}$	—	19	—	dB
Drain Efficiency	$\eta_D$	—	28	—	%
Intermodulation Distortion	IMD	—	-35	—	dBc

All published data at  $T_{CASE} = 25^\circ\text{C}$  unless otherwise indicated

**ESD:** Electrostatic discharge sensitive device—observe handling precautions!

## RF Characteristics (cont.)

### Two-tone Measurements (tested in Infineon test fixture)

$V_{DD} = 30\text{ V}$ ,  $I_{DQ} = 1.9\text{ A}$ ,  $P_{OUT} = 220\text{ W PEP}$ ,  $f = 1990\text{ MHz}$ , tone spacing = 1 MHz

Characteristic	Symbol	Min	Typ	Max	Unit
Gain	$G_{ps}$	17	18	—	dB
Drain Efficiency	$\eta_D$	40	41.5	—	%
Intermodulation Distortion	IMD	—	-29	-27	dBc

## DC Characteristics

Characteristic	Conditions	Symbol	Min	Typ	Max	Unit
Drain-Source Breakdown Voltage	$V_{GS} = 0\text{ V}$ , $I_{DS} = 10\text{ mA}$	$V_{(BR)DSS}$	65	—	—	V
Drain Leakage Current	$V_{DS} = 28\text{ V}$ , $V_{GS} = 0\text{ V}$	$I_{DSS}$	—	—	1.0	$\mu\text{A}$
Drain Leakage Current	$V_{DS} = 63\text{ V}$ , $V_{GS} = 0\text{ V}$	$I_{DSS}$	—	—	10.0	$\mu\text{A}$
On-State Resistance	$V_{GS} = 10\text{ V}$ , $V_{DS} = 0.1\text{ V}$	$R_{DS(on)}$	—	0.03	—	$\Omega$
Operating Gate Voltage	$V_{DS} = 30\text{ V}$ , $I_{DQ} = 1.9\text{ A}$	$V_{GS}$	2.3	2.8	3.3	V
Gate Leakage Current	$V_{GS} = 10\text{ V}$ , $V_{DS} = 0\text{ V}$	$I_{GSS}$	—	—	1.0	$\mu\text{A}$

## Maximum Ratings

Parameter	Symbol	Value	Unit
Drain-Source Voltage	$V_{DSS}$	65	V
Gate-Source Voltage	$V_{GS}$	-6 to +10	V
Junction Temperature	$T_J$	200	$^{\circ}\text{C}$
Storage Temperature Range	$T_{STG}$	-40 to +150	$^{\circ}\text{C}$
Thermal Resistance ( $T_{CASE} = 70^{\circ}\text{C}$ , 200 W CW)	$R_{\theta JC}$	0.262	$^{\circ}\text{C/W}$

## Ordering Information

Type and Version	Order Code	Package Description	Shipping
PTFB192503EL V1 R0	PTFB192503ELV1R0XTMA1	H-33288-6, bolt-down	Tape & Reel, 50pcs
PTFB192503EL V1 R250	PTFB192503ELV1R250XTMA1	H-33288-6, bolt-down	Tape & Reel, 250pcs
PTFB192503FL V2 R0	PTFB192503FLV2R0XTMA1	H-34288-4/2, earless	Tape & Reel, 50pcs
PTFB192503FL V2 R250	PTFB192503FLV2R250XTMA1	H-34288-4/2, earless	Tape & Reel, 250pcs

**Typical Performance** (data taken in a production test fixture)

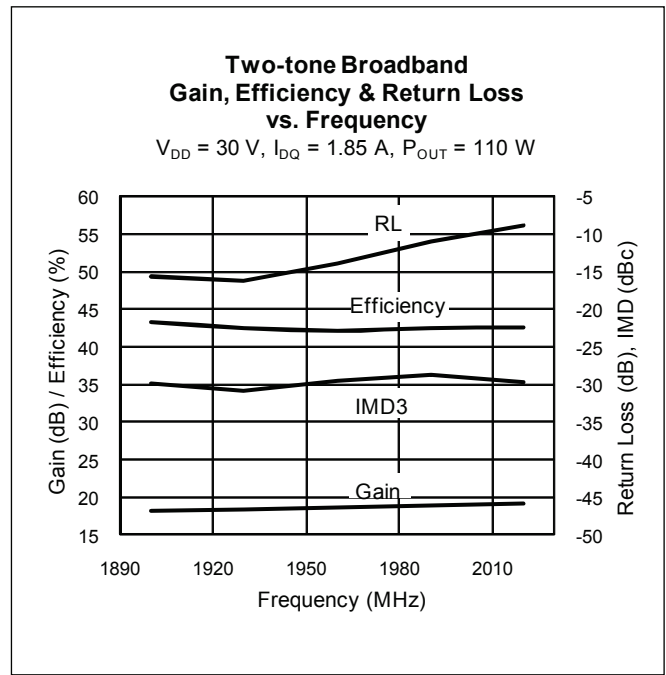
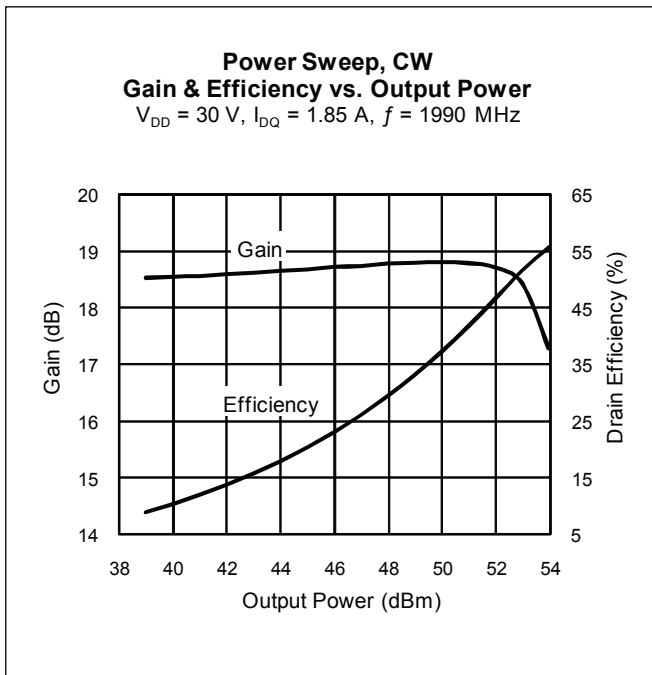
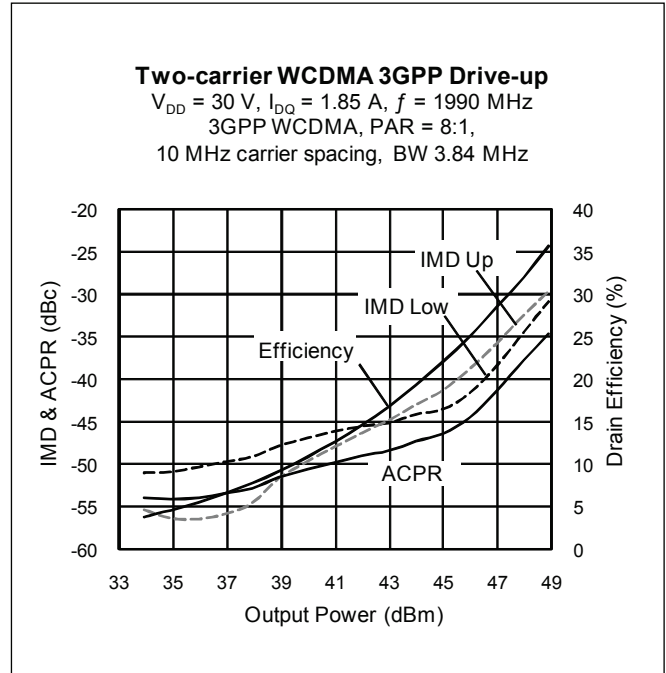
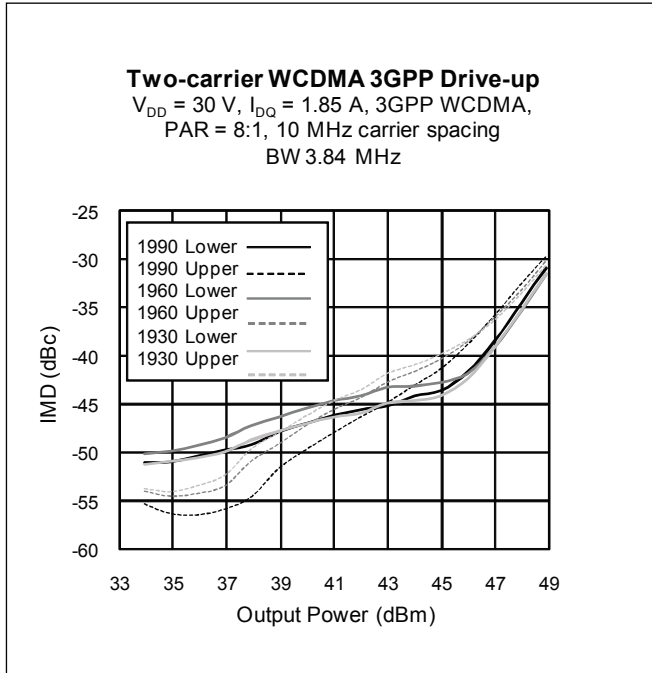

Typical Performance (cont.)

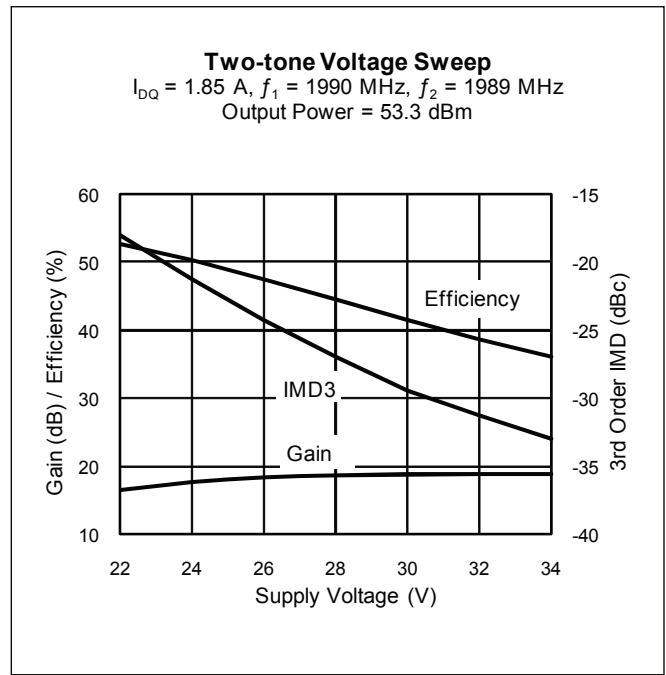
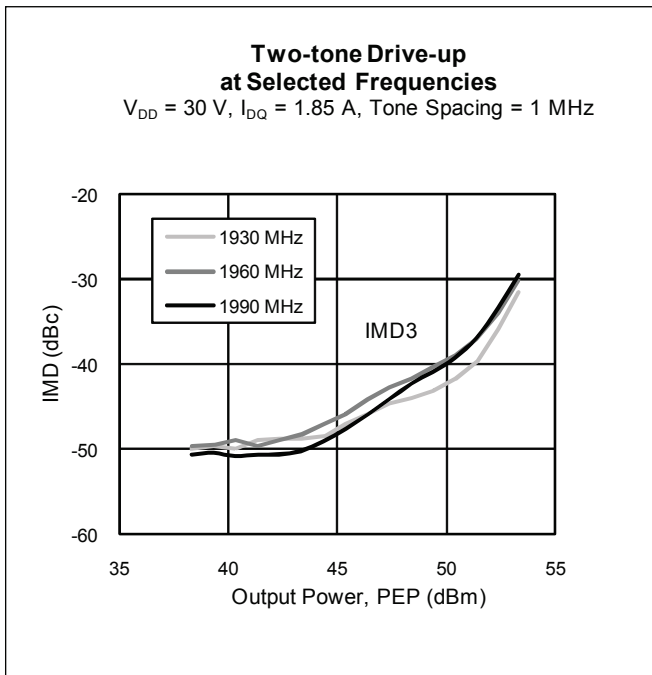
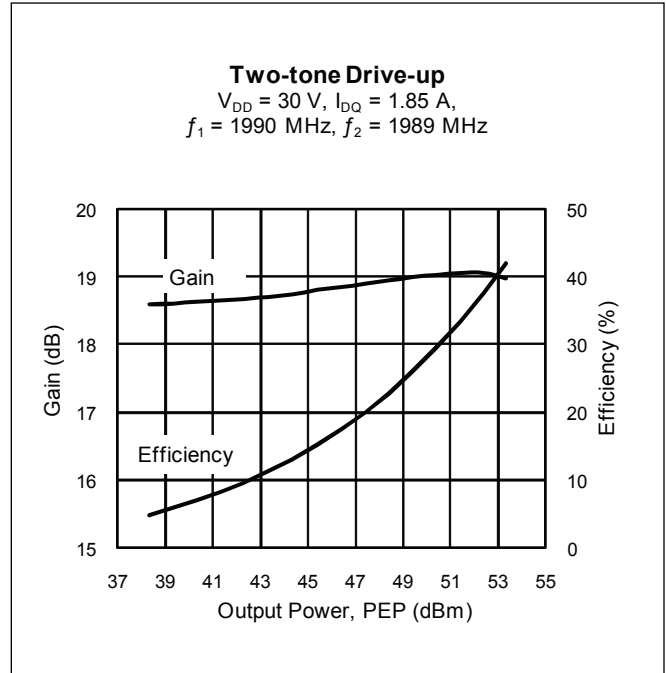
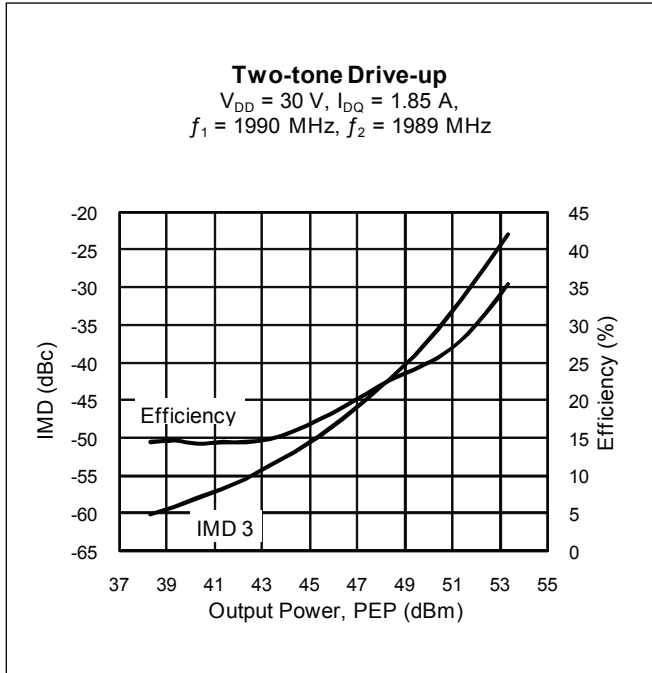

Typical Performance (cont.)

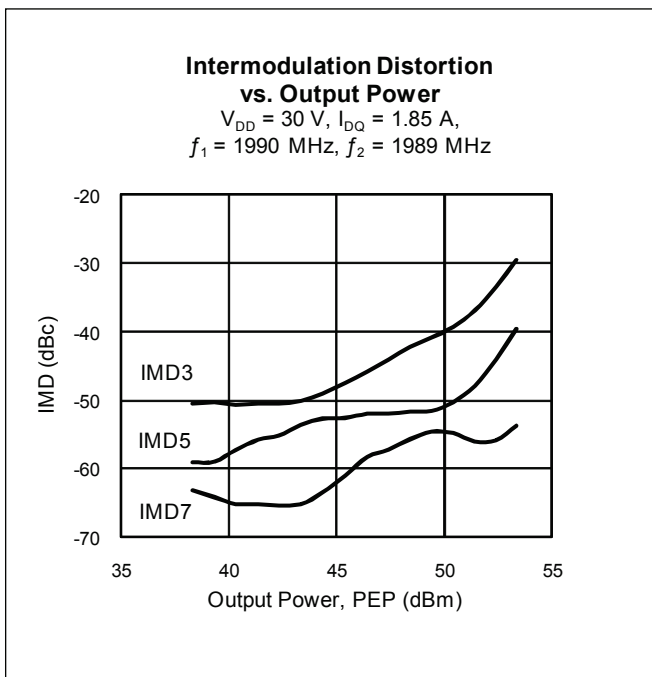
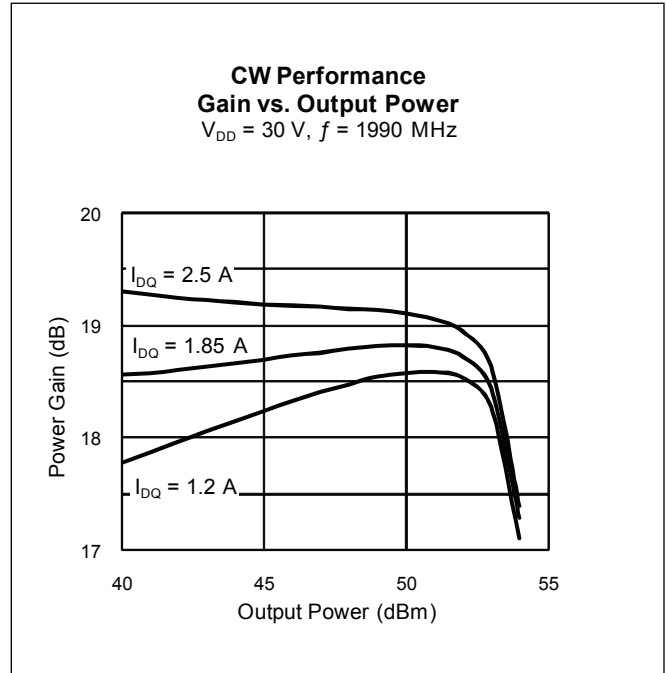
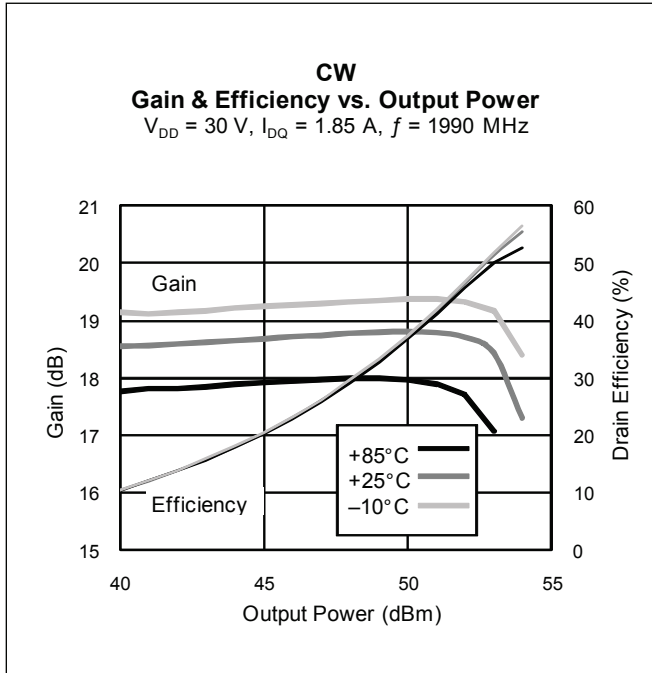

### Broadband Circuit Impedance

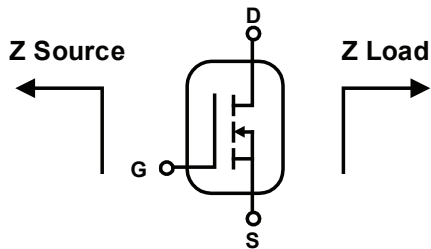

Frequency MHz	Z Source $\Omega$		Z Load $\Omega$	
	R	jX	R	jX
1900	2.63	-3.92	1.36	-4.49
1930	2.56	-3.67	1.33	-4.35
1960	2.48	-3.44	1.31	-4.21
1990	2.42	-3.21	1.28	-4.07
2020	2.35	-2.98	1.26	-3.93

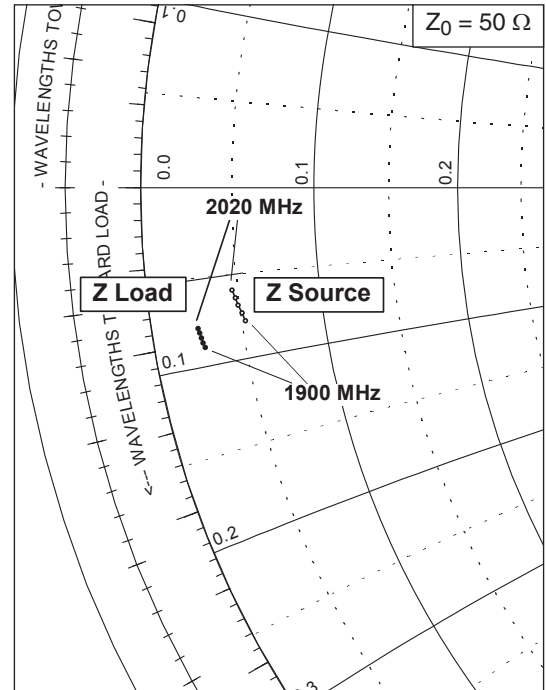

See next page for reference circuit information

### Reference Circuit

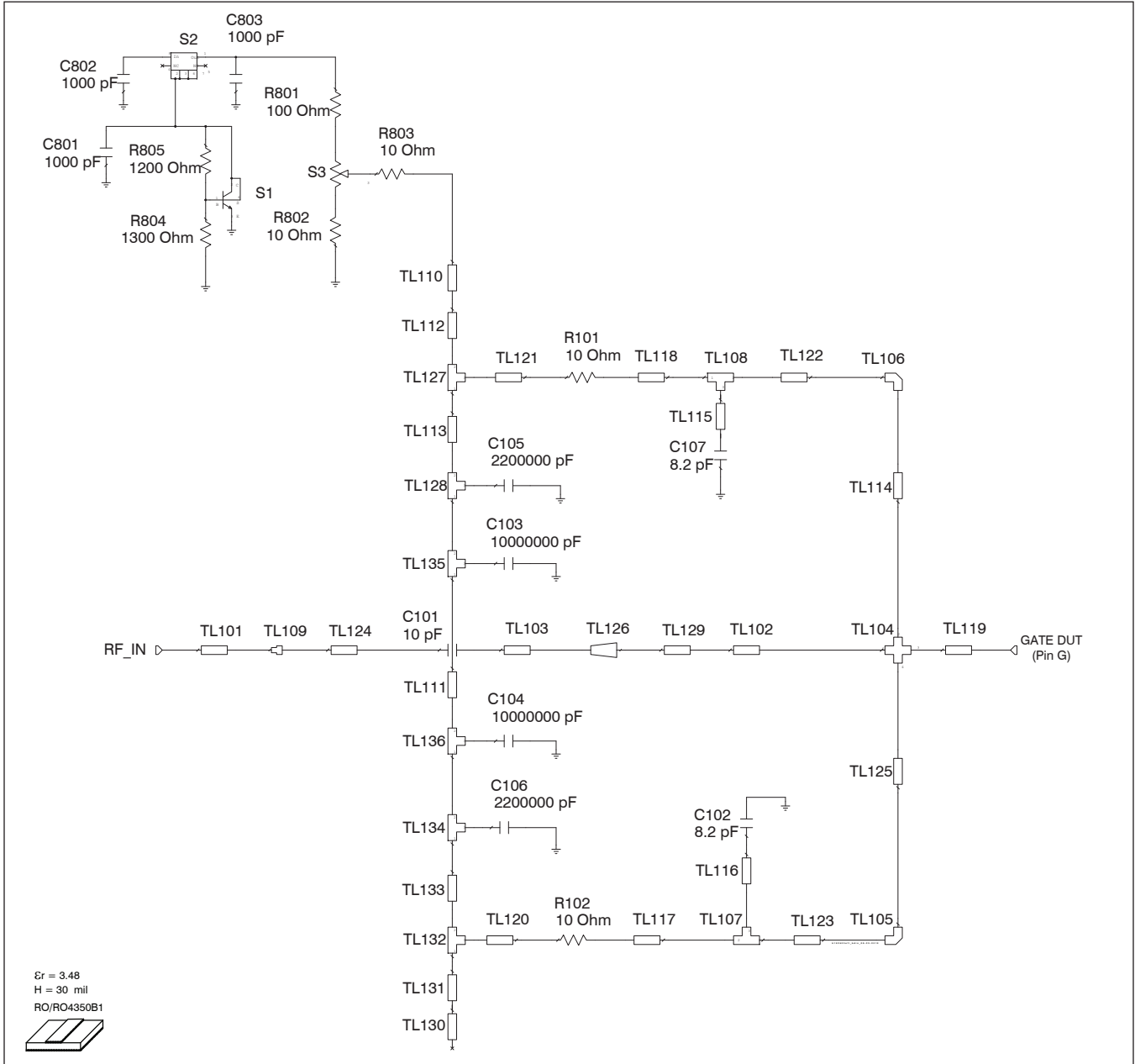

Reference circuit input schematic for  $f = 1990 \text{ MHz}$

Reference Circuit (cont.)

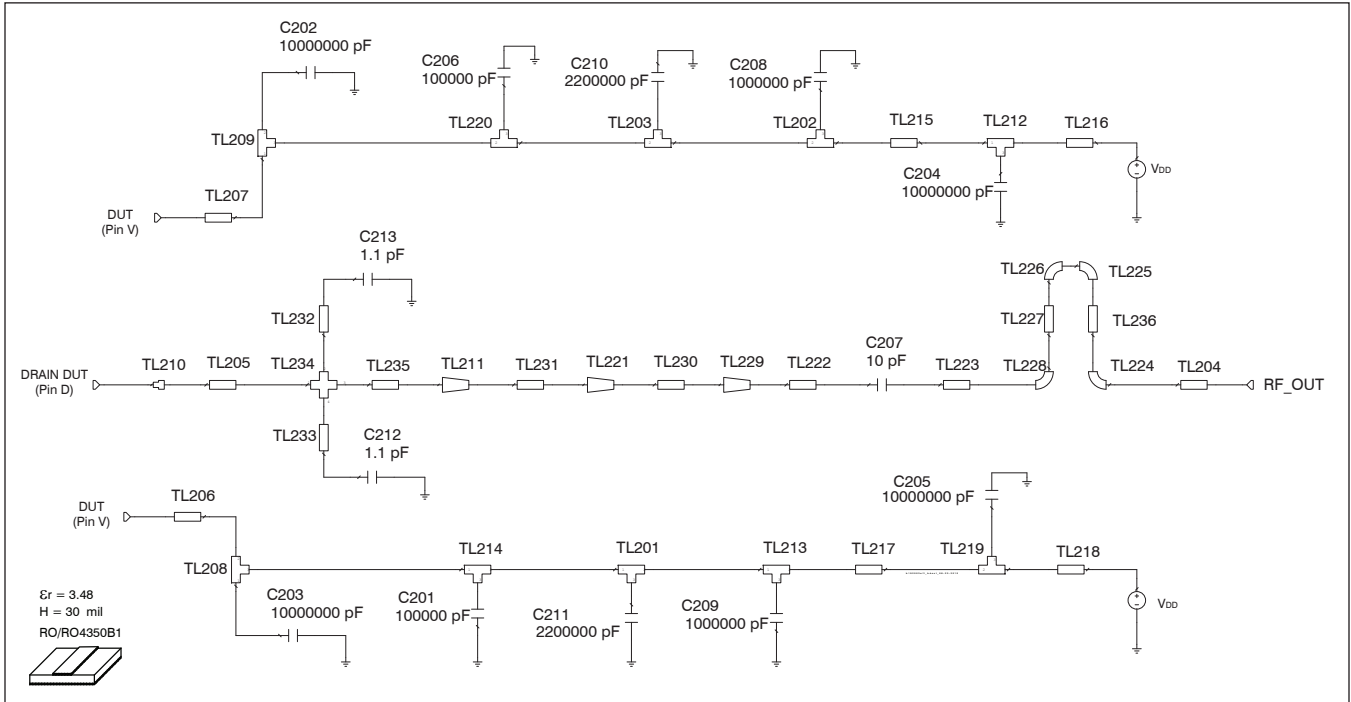

Reference circuit output schematic for  $f = 1990$  MHz

See next page for more reference circuit information



## Reference Circuit (cont.)

Description	
DUT	PTFB192503EL or PTFB192503FL
PCB	0.76 mm [.030"] thick, $\epsilon_r = 3.48$ , Rogers 4350, 1 oz. copper

### Electrical Characteristics at 1990 MHz

Transmission Line	Electrical Characteristics	Dimensions: mm	Dimensions: mils
<b>Input</b>			
TL224	$0.000 \lambda$ , 144.35 $\Omega$	W1 = 0.025, W2 = 0.025, W3 = 0.025	W1 = 1, W2 = 1, W3 = 1
TL101	$0.037 \lambda$ , 51.58 $\Omega$	W = 1.651, L = 3.358	W = 65, L = 132
TL102	$0.053 \lambda$ , 9.67 $\Omega$	W = 13.970, L = 4.470	W = 550, L = 176
TL103	$0.033 \lambda$ , 51.58 $\Omega$	W = 1.651, L = 3.018	W = 65, L = 119
TL104		W1 = 13.970, W2 = 0.762, W3 = 13.970, W4 = 0.762	W1 = 550, W2 = 30, W3 = 550, W4 = 30
TL105, TL106		W = 0.762	W = 30
TL107, TL108	$0.011 \lambda$ , 78.27 $\Omega$	W1 = 0.762, W2 = 0.762, W3 = 1.016	W1 = 30, W2 = 30, W3 = 40
TL109		W1 = 1.651, W2 = 2.032	W1 = 65, W2 = 80
TL110, TL130	$0.015 \lambda$ , 38.82 $\Omega$	W = 2.540, L = 1.321	W = 100, L = 52
TL111	$0.071 \lambda$ , 92.53 $\Omega$	W = 0.508, L = 6.756	W = 20, L = 266
TL112	$0.016 \lambda$ , 68.02 $\Omega$	W = 1.016, L = 1.524	W = 40, L = 60
TL113, TL133	$0.024 \lambda$ , 78.27 $\Omega$	W = 0.762, L = 2.286	W = 30, L = 90
TL114, TL125	$0.023 \lambda$ , 78.27 $\Omega$	W = 0.762, L = 2.159	W = 30, L = 85
TL115, TL116	$0.001 \lambda$ , 68.02 $\Omega$	W = 1.016, L = 0.127	W = 40, L = 5
TL117, TL118	$0.014 \lambda$ , 78.27 $\Omega$	W = 0.762, L = 1.270	W = 30, L = 50
TL119	$0.024 \lambda$ , 9.67 $\Omega$	W = 13.970, L = 1.981	W = 550, L = 78
TL120, TL121	$0.007 \lambda$ , 68.02 $\Omega$	W = 1.016, L = 0.686	W = 40, L = 27
TL122, TL123	$0.125 \lambda$ , 78.27 $\Omega$	W = 0.762, L = 11.684	W = 30, L = 460
TL124	$0.008 \lambda$ , 45.17 $\Omega$	W = 2.032, L = 0.762	W = 80, L = 30
TL126 (taper)	$0.030 \lambda$ , 9.67 $\Omega$ / 51.58 $\Omega$	W1 = 13.970, W2 = 1.651, L = 2.515	W1 = 550, W2 = 65, L = 99
TL127, TL132	$0.011 \lambda$ , 68.02 $\Omega$	W1 = 1.016, W2 = 1.016, W3 = 1.016	W1 = 40, W2 = 40, W3 = 40
TL128	$0.022 \lambda$ , 78.27 $\Omega$	W1 = 0.762, W2 = 0.762, W3 = 2.032	W1 = 30, W2 = 30, W3 = 80
TL129	$0.077 \lambda$ , 9.67 $\Omega$	W = 13.970, L = 6.502	W = 550, L = 256
TL131	$0.016 \lambda$ , 68.02 $\Omega$	W = 1.016, L = 1.524	W = 40, L = 60
TL134	$0.022 \lambda$ , 78.27 $\Omega$	W1 = 0.762, W2 = 0.762, W3 = 2.032	W1 = 30, W2 = 30, W3 = 80
TL135, TL136	$0.016 \lambda$ , 92.53 $\Omega$	W1 = 0.508, W2 = 0.508, W3 = 1.524	W1 = 20, W2 = 20, W3 = 60

table continued on page 10

## Reference Circuit (cont.)

### Electrical Characteristics at 1990 MHz

Transmission Line	Electrical Characteristics	Dimensions: mm	Dimensions: mils
<b>Output</b>			
TL201, TL202, TL203, TL213	0.026 $\lambda$ , 34.08 $\Omega$	W1 = 3.048, W2 = 3.048, W3 = 2.286	W1 = 120, W2 = 120, W3 = 90
TL204	0.012 $\lambda$ , 51.58 $\Omega$	W = 1.651, L = 1.118	W = 65, L = 44
TL205	0.084 $\lambda$ , 6.86 $\Omega$	W = 20.320, L = 6.985	W = 800, L = 275
TL206	0.029 $\lambda$ , 23.60 $\Omega$	W = 4.928, L = 2.540	W = 194, L = 100
TL207	0.029 $\lambda$ , 23.79 $\Omega$	W = 4.877, L = 2.540	W = 192, L = 100
TL208, TL209, TL212	0.034 $\lambda$ , 34.08 $\Omega$	W1 = 3.048, W2 = 3.048, W3 = 3.048	W1 = 120, W2 = 120, W3 = 120
TL210		W1 = 12.700, W2 = 17.780	W1 = 500, W2 = 700
TL211 (taper)	0.019 $\lambda$ , 6.86 $\Omega$ / 8.37 $\Omega$	W1 = 20.320, W2 = 16.383, L = 1.575	W1 = 800, W2 = 645, L = 62
TL214, TL220	0.009 $\lambda$ , 34.08 $\Omega$	W1 = 3.048, W2 = 3.048, W3 = 0.762	W1 = 120, W2 = 120, W3 = 30
TL215, TL217	0.118 $\lambda$ , 34.08 $\Omega$	W = 3.048, L = 10.516	W = 120, L = 414
TL216	0.019 $\lambda$ , 34.08 $\Omega$	W = 3.048, L = 1.702	W = 120, L = 67
TL218	0.025 $\lambda$ , 34.08 $\Omega$	W = 3.048, L = 2.210	W = 120, L = 87
TL219	0.034 $\lambda$ , 34.08 $\Omega$	W1 = 3.048, W2 = 3.048, W3 = 3.048	W1 = 120, W2 = 120, W3 = 120
TL221 (taper)	0.041 $\lambda$ , 8.37 $\Omega$ / 19.45 $\Omega$	W1 = 16.383, W2 = 6.248, L = 3.429	W1 = 645, W2 = 246, L = 135
TL222	0.007 $\lambda$ , 51.58 $\Omega$	W = 1.651, L = 0.635	W = 65, L = 25
TL223	0.011 $\lambda$ , 45.17 $\Omega$	W = 2.032, L = 1.016	W = 80, L = 40
TL224, TL225, TL226, TL228		W = 0.002, ANG = 90, R = 0.002	W = 2, ANG = 3543307, R = 70
TL227	0.014 $\lambda$ , 51.58 $\Omega$	W = 1.651, L = 1.270	W = 65, L = 50
TL229 (taper)	0.019 $\lambda$ , 19.45 $\Omega$ / 51.58 $\Omega$	W1 = 6.248, W2 = 1.651, L = 1.651	W1 = 246, W2 = 65, L = 65
TL230	0.000 $\lambda$ , 19.45 $\Omega$	W = 6.248, L = 0.025	W = 246, L = 1
TL231	0.000 $\lambda$ , 8.37 $\Omega$	W = 16.383, L = 0.025	W = 645, L = 1
TL232, TL233	0.000 $\lambda$ , 146.88 $\Omega$	W = 0.025, L = 0.025	W = 1, L = 1
TL234		W1 = 20.320, W2 = 0.025, W3 = 20.320, W4 = 0.025	W1 = 800, W2 = 1, W3 = 800, W4 = 1
TL235	0.005 $\lambda$ , 6.86 $\Omega$	W = 20.320, L = 0.406	W = 800, L = 16
TL236	0.014 $\lambda$ , 51.58 $\Omega$	W = 1.651, L = 1.270	W = 65, L = 50

Reference Circuit (cont.)

Circuit Assembly Information

Test Fixture Part No. LTN/PTFB192503EF

Find Gerber files for this test fixture on the Infineon Web site at <http://www.infineon.com/rfpower>

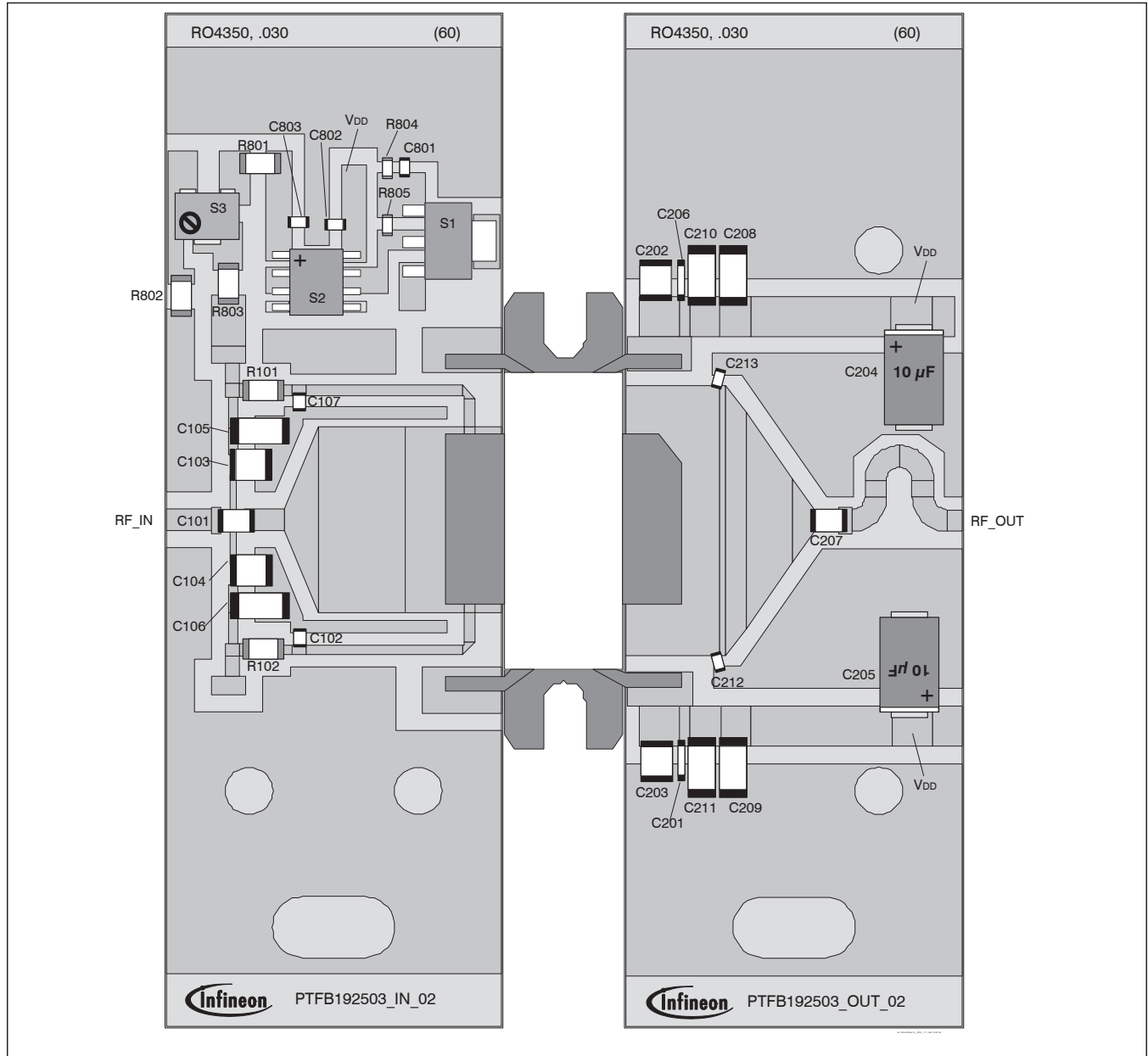

Reference circuit assembly diagram (not to scale)

### Reference Circuit (cont.)

Component	Description	Suggested Manufacturer	P/N
<b>Input</b>			
C101	Chip capacitor, 10 pF	ATC	ATC100B100FW500XB
C102, C107	Chip capacitor, 8.2 pF	ATC	ATC100A8R2BW150XB
C103, C104	Capacitor, 10 $\mu$ F	Digi-Key	587-1818-2-ND
C105, C106	Chip capacitor, 2.2 $\mu$ F	Digi-Key	445-1447-2-ND
C801, C802, C803	Capacitor, 1000 pF	Digi-Key	PCC1772CT-ND
R101, R102, R802, R803	Resistor, 10 $\Omega$	Digi-Key	P10ECT-ND
R801	Resistor, 100 $\Omega$	Digi-Key	P100ECT-ND
R804	Resistor, 1300 $\Omega$	Digi-Key	P1.3KGCT-ND
R805	Resistor, 1200 $\Omega$	Digi-Key	P1.2KGCT-ND
S1	Transistor	Digi-Key	BCP5616TA-ND
S2	Voltage Regulator	Digi-Key	LM78L05ACM-ND
S3	Potentiometer, 2k $\Omega$	Digi-Key	3224W-202ECT-ND
<b>Output</b>			
C201, C206	Chip capacitor, 0.1 $\mu$ F	Digi-Key	399-1267-2-ND
C202, C203	Chip capacitor, 10 $\mu$ F	Digi-Key	587-1818-2-ND
C204, C205	Capacitor, 10 $\mu$ F	Digi-Key	281M5002106K
C207	Capacitor, 10 pF	ATC	ATC100B100FW500XB
C208, C209	Chip capacitor, 1 $\mu$ F	Digi-Key	445-1411-2-ND
C210, C211	Chip capacitor, 2.2 $\mu$ F	Digi-Key	445-1447-2-ND
C212, C213	Chip capacitor, 1.1 pF	ATC	ATC100A1R1BW150XB

## Package Outline Specifications

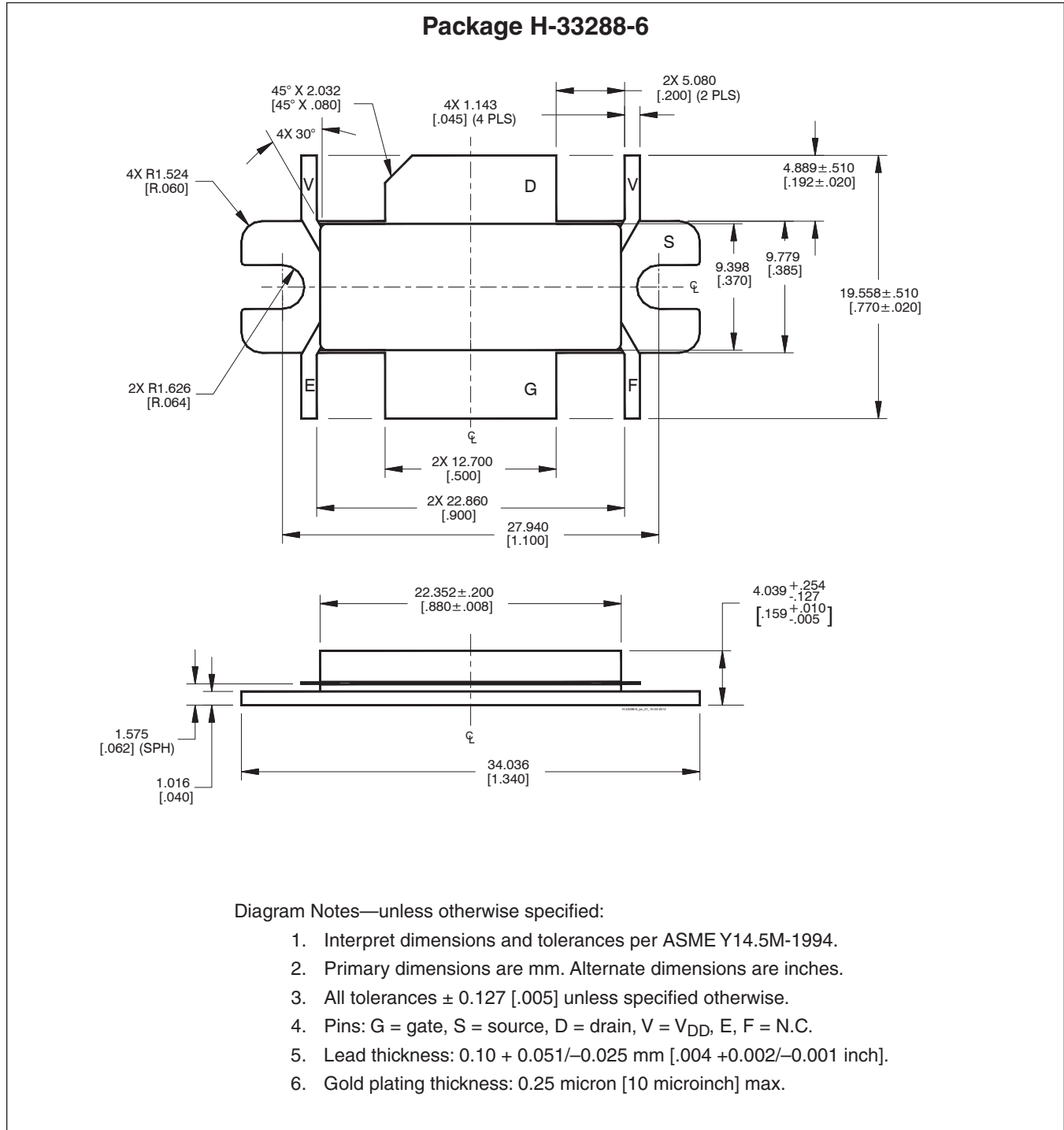

Package Outline Specifications (cont.)

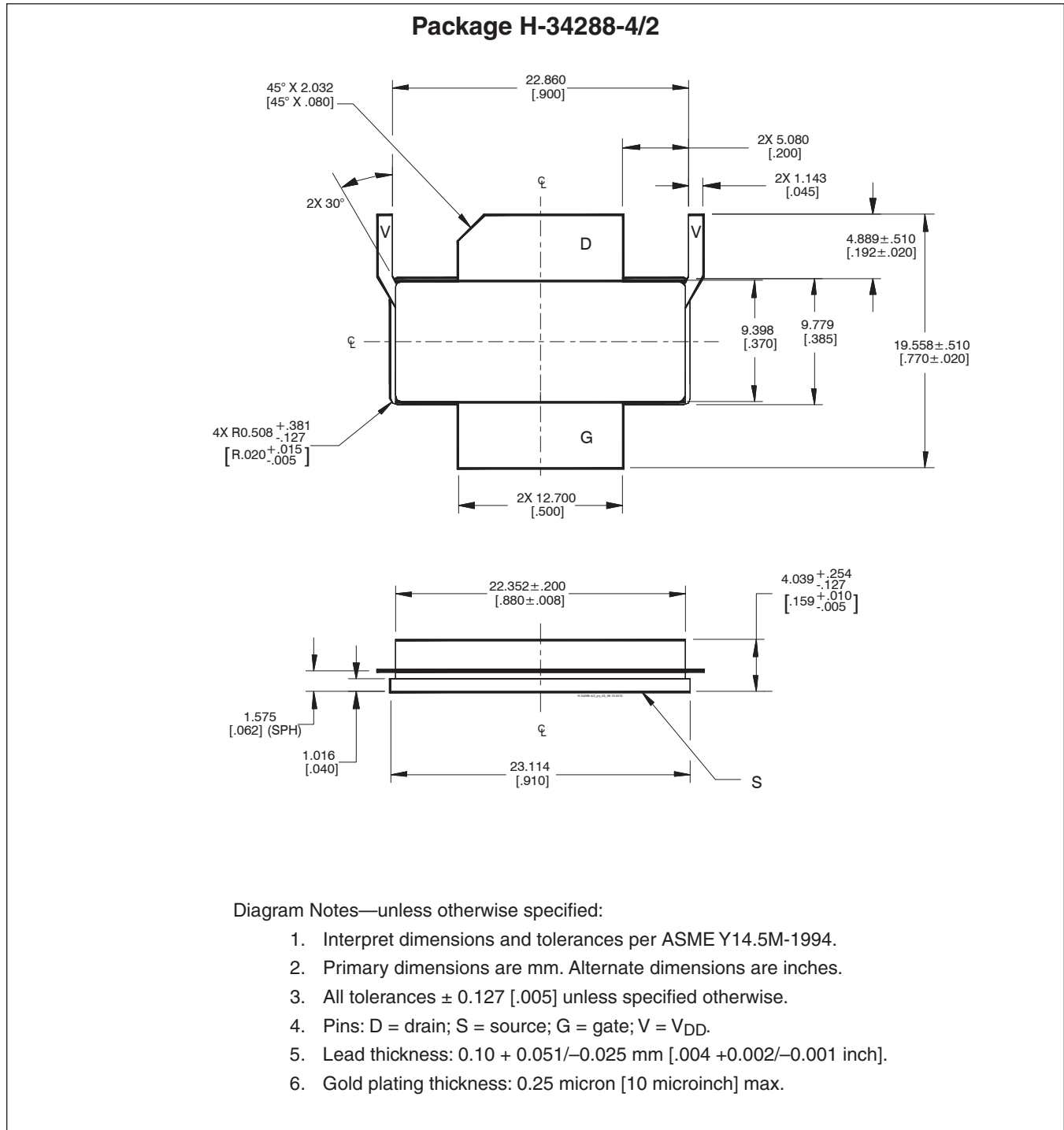

Find the latest and most complete information about products and packaging at the Infineon Internet page  
<http://www.infineon.com/rfpower>

<b>Revision History:</b>	2016-06-13	Data Sheet
Previous Version:	2010-11-09, Data Sheet	
Page	Subjects (major changes since last revision)	
2	Updated ordering code to R0	

### We Listen to Your Comments

Any information within this document that you feel is wrong, unclear or missing at all?  
Your feedback will help us to continuously improve the quality of this document.  
Please send your proposal (including a reference to this document) to:

[highpowerRF@infineon.com](mailto:highpowerRF@infineon.com)

To request other information, contact us at:  
+1 877 465 3667 (1-877-GO-LDMOS) USA  
or +1 408 776 0600 International

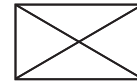

**Edition 2016-06-13**

**Published by**  
**Infineon Technologies AG**  
**81726 Munich, Germany**

**© 2009 Infineon Technologies AG**  
**All Rights Reserved.**

### Legal Disclaimer

The information given in this document shall in no event be regarded as a guarantee of conditions or characteristics. With respect to any examples or hints given herein, any typical values stated herein and/or any information regarding the application of the device, Infineon Technologies hereby disclaims any and all warranties and liabilities of any kind, including without limitation, warranties of non-infringement of intellectual property rights of any third party.

### Information

For further information on technology, delivery terms and conditions and prices, please contact the nearest Infineon Technologies Office ([www.infineon.com/rfpower](http://www.infineon.com/rfpower)).

### Warnings

Due to technical requirements, components may contain dangerous substances. For information on the types in question, please contact the nearest Infineon Technologies Office.

Infineon Technologies components may be used in life-support devices or systems only with the express written approval of Infineon Technologies, if a failure of such components can reasonably be expected to cause the failure of that life-support device or system or to affect the safety or effectiveness of that device or system. Life support devices or systems are intended to be implanted in the human body or to support and/or maintain and sustain and/or protect human life. If they fail, it is reasonable to assume that the health of the user or other persons may be endangered.