

## Thermally-Enhanced High Power RF LDMOS FET 12 W, 50 V, 390 – 450 MHz

### Description

The PTVA030121EA is an LDMOS FET characterized for use in power amplifier applications in the 390 MHz to 450 MHz frequency band. Features include high gain and a thermally-enhanced package. Manufactured with Infineon's advanced LDMOS process, this device provides excellent thermal performance and superior reliability.

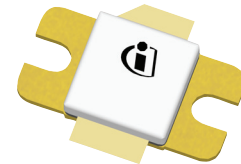

PTVA030121EA  
Package H-36265-2

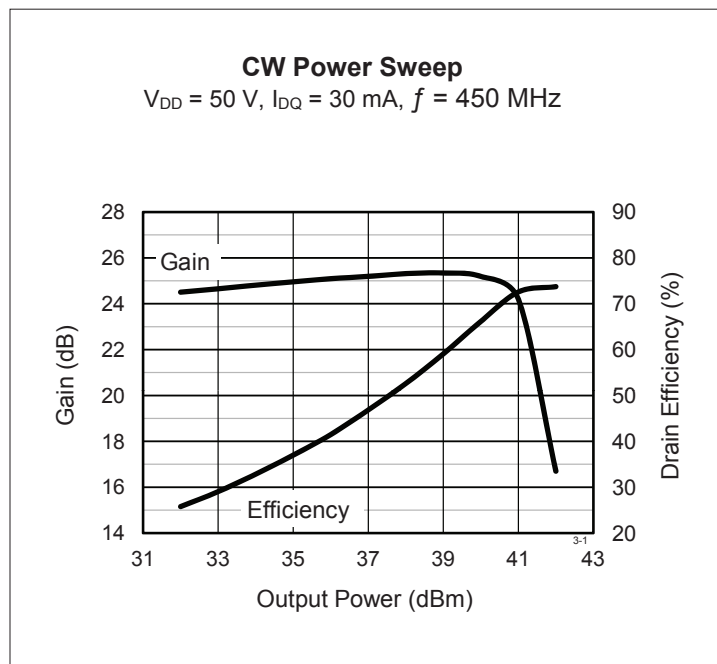

### Features

- Unmatched input and output
- Integrated ESD protection
- Human Body Model Class 1C (per ANSI/ESDA/JEDEC JS-001)
- High gain, low thermal resistance
- Excellent ruggedness
- Capable of withstanding a 13:1 load mismatch at 50 V, 12 W, CW conditions
- Pb-free and RoHS compliant

### RF Characteristics

#### CW Measurements

$V_{DD} = 50\text{ V}$ ,  $I_{DQ} = 50\text{ mA}$ ,  $P_{OUT} = 12\text{ W}$ ,  $f = 450\text{ MHz}$

Characteristic	Symbol	Min	Typ	Max	Unit
Gain	Gps	23	25	—	dB
Drain Efficiency	$\eta_D$	66	69	—	%

All published data at  $T_{CASE} = 25^\circ\text{C}$  unless otherwise indicated

ESD: Electrostatic discharge sensitive device—observe handling precautions!

## DC Characteristics

Characteristic	Conditions	Symbol	Min	Typ	Max	Unit
Drain-Source Breakdown Voltage	$V_{GS} = 0\text{ V}$ , $I_{DS} = 1\text{ mA}$	$V_{(BR)DSS}$	105	—	—	V
Drain Leakage Current	$V_{DS} = 50\text{ V}$ , $V_{GS} = 0\text{ V}$	$I_{DSS}$	—	—	1.0	$\mu\text{A}$
	$V_{DS} = 105\text{ V}$ , $V_{GS} = 0\text{ V}$	$I_{DSS}$	—	—	10.0	$\mu\text{A}$
On-State Resistance	$V_{GS} = 10\text{ V}$ , $V_{DS} = 0.1\text{ V}$	$R_{DS(on)}$	—	2.8	—	$\Omega$
Operating Gate Voltage	$V_{DS} = 50\text{ V}$ , $I_{DQ} = 50\text{ mA}$	$V_{GS}$	—	3.6	—	V
Gate Leakage Current	$V_{GS} = 10\text{ V}$ , $V_{DS} = 0\text{ V}$	$I_{GSS}$	—	—	1.0	$\mu\text{A}$

## Maximum Ratings

Parameter	Symbol	Value	Unit
Drain-Source Voltage	$V_{DSS}$	105	V
Gate-Source Voltage	$V_{GS}$	-6 to +12	V
Junction Temperature	$T_J$	200	$^{\circ}\text{C}$
Storage Temperature Range	$T_{STG}$	-65 to +150	$^{\circ}\text{C}$
Thermal Resistance ( $T_{CASE} 70^{\circ}\text{C}$ , 12 W CW)	$R_{\theta JC}$	6.5	$^{\circ}\text{C/W}$

## Ordering Information

Type and Version	Order Code	Package and Description	Shipping
PTVA030121EA V1 R0	PTVA030121EAV1R0XTMA1	H-36265-2, bolt-down	Tape & Reel, 50pcs
PTVA030121EA V1 R250	PTVA030121EAV1R250XTMA1	H-36265-2, bolt-down	Tape & Reel, 250pcs

**Typical Performance** (data taken in a production test circuit)

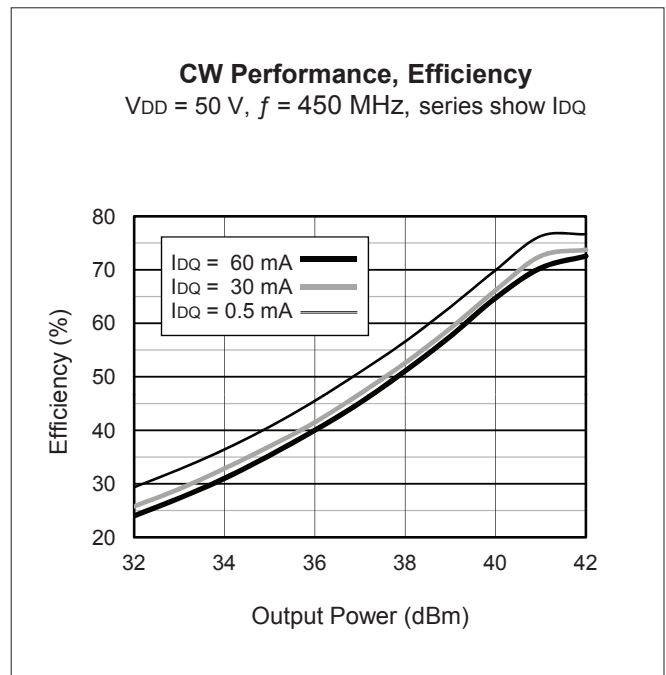
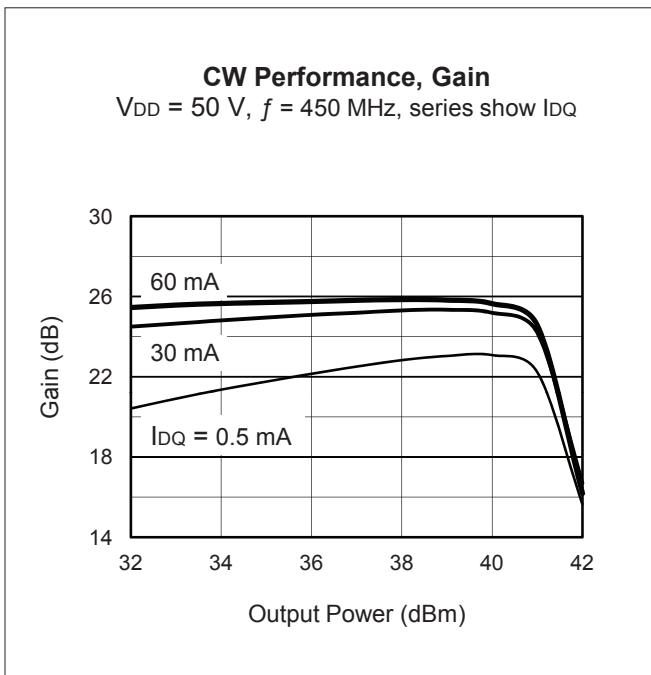
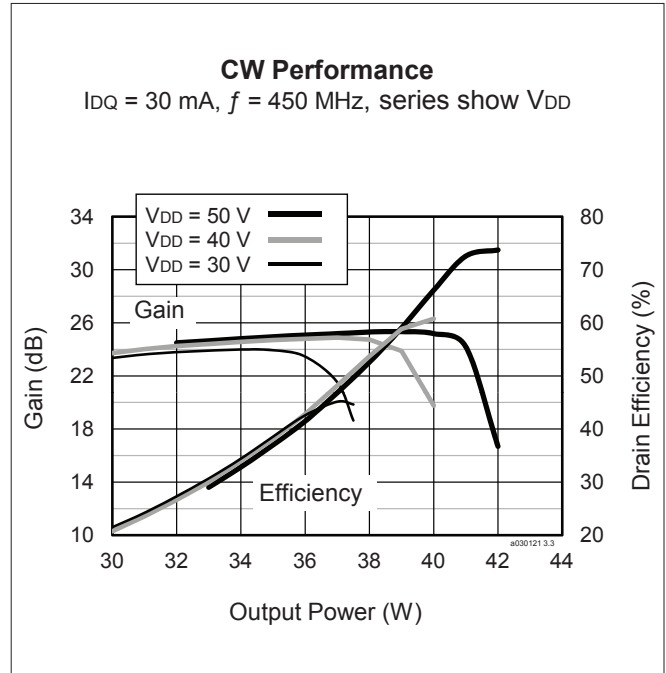
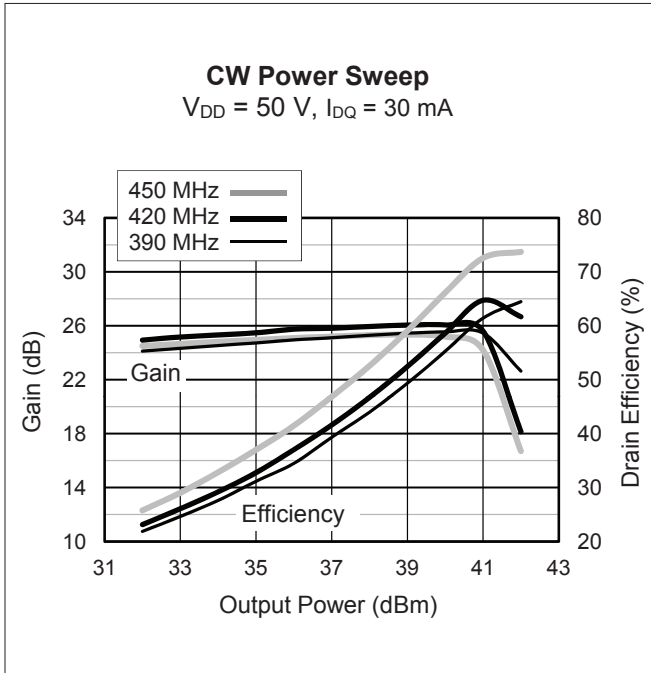

### Broadband Circuit Impedance

Frequency MHz	Z Source $\Omega$		Z Load $\Omega$	
	R	jX	R	jX
390	22.20	34.88	4.26	15.04
405	21.95	34.74	4.46	15.82
420	21.39	34.99	4.66	16.62
435	20.61	35.80	4.88	17.42
450	19.77	37.03	5.11	18.23

### Reference Circuit

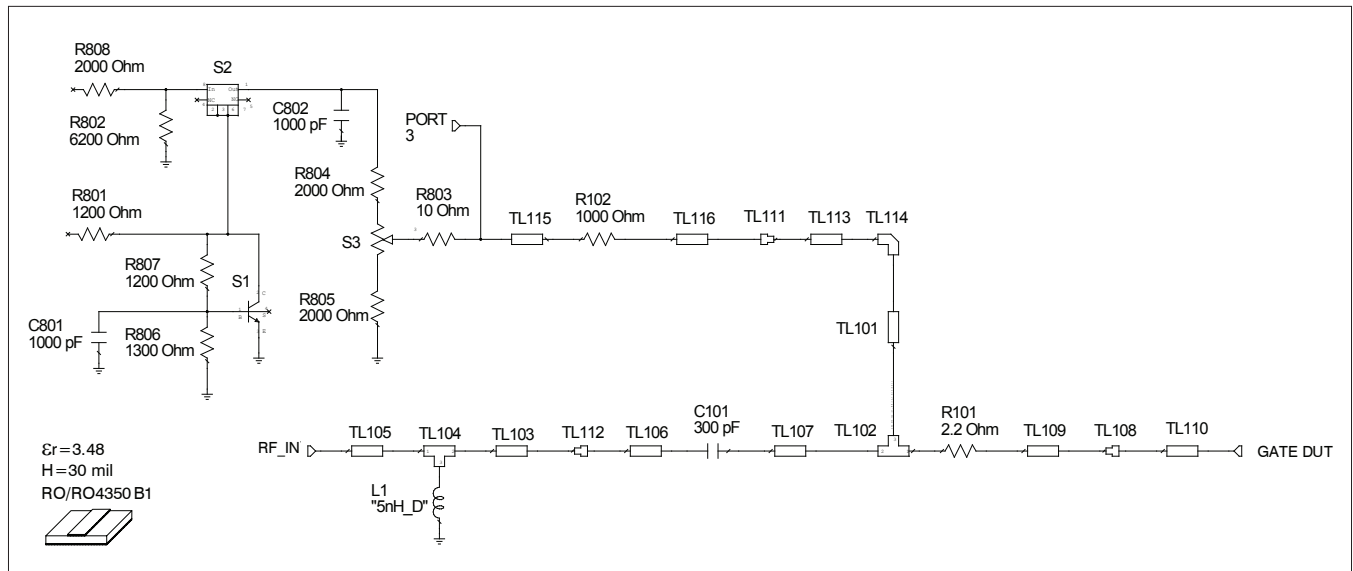

Reference circuit input schematic for  $f = 450$  MHz

Reference Circuit (cont.)

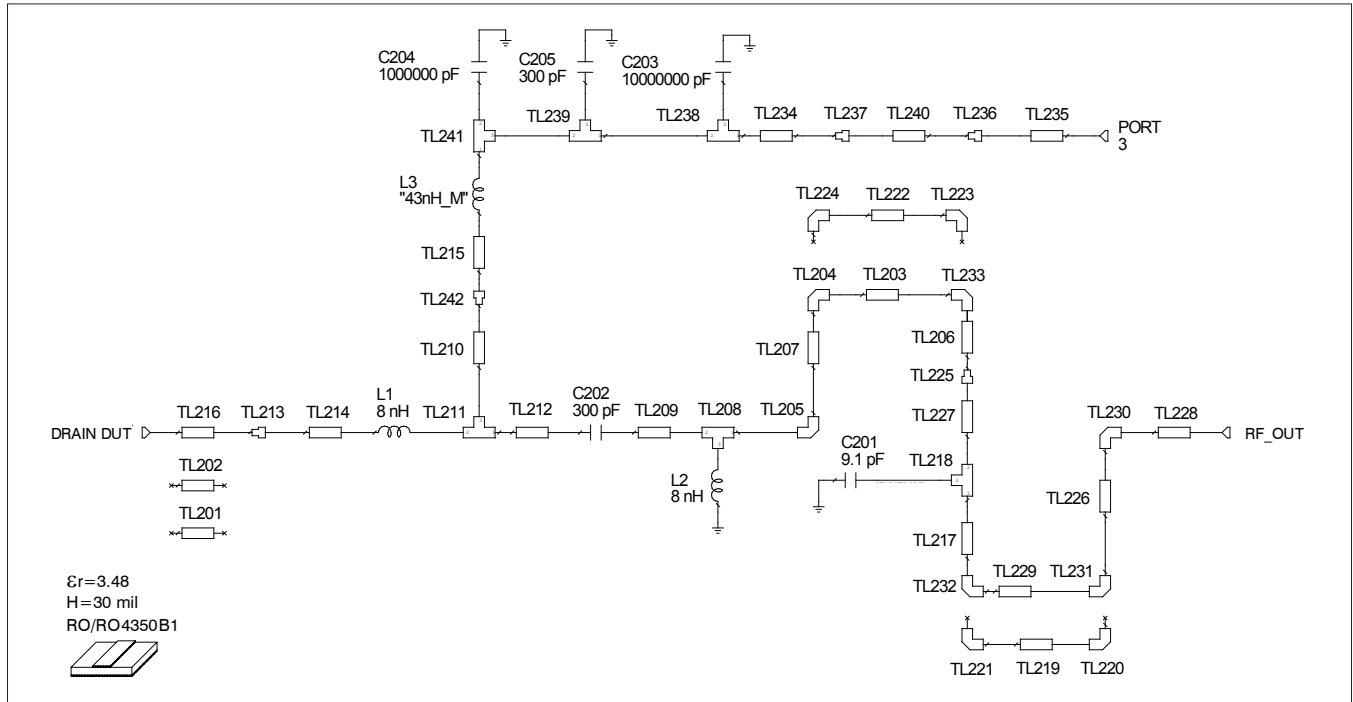

Reference circuit output schematic for  $f = 450 \text{ MHz}$

Reference Circuit Assembly

DUT	PTFA030121EA
Test Fixture Part No.	LTN/PTFA030121EA
PCB	Rogers RO4350, 0.508 mm [0.020"] thick, 1 oz. copper, $\epsilon_r = 3.48$
Find Gerber files for this test fixture on the Infineon Web site at <a href="http://www.infineon.com/rfpower">http://www.infineon.com/rfpower</a>	

Electrical Characteristics at 450 MHz

Transmission Line	Electrical Characteristics	Dimensions: mm	Dimensions: mils
<b>Input</b>			
TL101	0.009 $\lambda$ , 92.76 $\Omega$	W = 0.51, L = 3.81	W = 20, L = 150
TL102	0.001 $\lambda$ , 45.29 $\Omega$	W1 = 2.03, W2 = 2.03, W3 = 0.51	W1 = 80, W2 = 80, W3 = 20
TL103	0.001 $\lambda$ , 52.21 $\Omega$	W = 1.63, L = 0.43	W = 64, L = 17
TL105	0.025 $\lambda$ , 52.21 $\Omega$	W = 1.63, L = 10.13	W = 64, L = 39
TL106, TL109	0.003 $\lambda$ , 45.29 $\Omega$	W = 2.03, L = 1.27	W = 80, L = 50
TL107	0.002 $\lambda$ , 45.29 $\Omega$	W = 2.03, L = 0.76	W = 80, L = 30
TL110	0.013 $\lambda$ , 16.51 $\Omega$	W = 7.62, L = 5.08	W = 300, L = 200
TL113	0.002 $\lambda$ , 92.76 $\Omega$	W = 0.51, L = 1.02	W = 20, L = 40
TL115	0.013 $\lambda$ , 54.31 $\Omega$	W = 1.52, L = 5.08	W = 60, L = 200
TL116	0.003 $\lambda$ , 54.31 $\Omega$	W = 1.52, L = 1.02	W = 60, L = 40

table continued next page

**Reference Circuit** (cont.)

**Electrical Characteristics at 450 MHz**

Transmission Line	Electrical Characteristics	Dimensions: mm	Dimensions: mils
<b>Output</b>			
TL201, TL202	0.005 $\lambda$ , 45.29 $\Omega$	W = 2.03, L = 2.04	W = 80, L = 81
TL203	0.006 $\lambda$ , 38.92 $\Omega$	W = 2.54, L = 2.54	W = 100, L = 100
TL206, TL207	0.029 $\lambda$ , 38.92 $\Omega$	W = 2.54, L = 11.43	W = 100, L = 450
TL209	0.009 $\lambda$ , 38.92 $\Omega$	W = 2.54, L = 3.56	W = 100, L = 140
TL210	0.018 $\lambda$ , 78.46 $\Omega$	W = 0.76, L = 7.62	W = 30, L = 300
TL211	0.002 $\lambda$ , 25.11 $\Omega$	W1 = 4.57, W2 = 4.57, W3 = 0.76	W1 = 180, W2 = 180, W3 = 30
TL212	0.003 $\lambda$ , 25.11 $\Omega$	W = 4.57, L = 1.27	W = 180, L = 50
TL214	0.004 $\lambda$ , 25.11 $\Omega$	W = 4.57, L = 1.52	W = 180, L = 60
TL215	0.010 $\lambda$ , 23.09 $\Omega$	W = 5.08, L = 3.81	W = 200, L = 150
TL216	0.013 $\lambda$ , 16.51 $\Omega$	W = 7.62, L = 5.08	W = 300, L = 200
TL217	0.018 $\lambda$ , 52.21 $\Omega$	W = 1.63, L = 7.29	W = 64, L = 287
TL219	0.006 $\lambda$ , 52.21 $\Omega$	W = 1.63, L = 2.41	W = 64, L = 95
TL222	0.006 $\lambda$ , 38.92 $\Omega$	W = 2.54, L = 2.54	W = 100, L = 100
TL226	0.018 $\lambda$ , 52.21 $\Omega$	W = 1.63, L = 7.34	W = 64, L = 289
TL227	0.002 $\lambda$ , 52.21 $\Omega$	W = 1.63, L = 0.84	W = 64, L = 33
TL228	0.006 $\lambda$ , 52.21 $\Omega$	W = 1.63, L = 2.30	W = 64, L = 91
TL229	0.006 $\lambda$ , 52.21 $\Omega$	W = 1.63, L = 2.41	W = 64, L = 95
TL234	0.005 $\lambda$ , 27.14 $\Omega$	W = 4.14, L = 2.12	W = 163, L = 84
TL235	0.014 $\lambda$ , 34.38 $\Omega$	W = 3.02, L = 5.51	W = 119, L = 2 17
TL240	0.026 $\lambda$ , 61.53 $\Omega$	W = 1.23, L = 10.63	W = 48, L = 419
TL241	0.010 $\lambda$ , 38.92 $\Omega$	W1 = 2.54, W2 2.54, W3 = 4.14	W1 = 100, W2 = 100, W3 = 163

Reference Circuit (cont.)

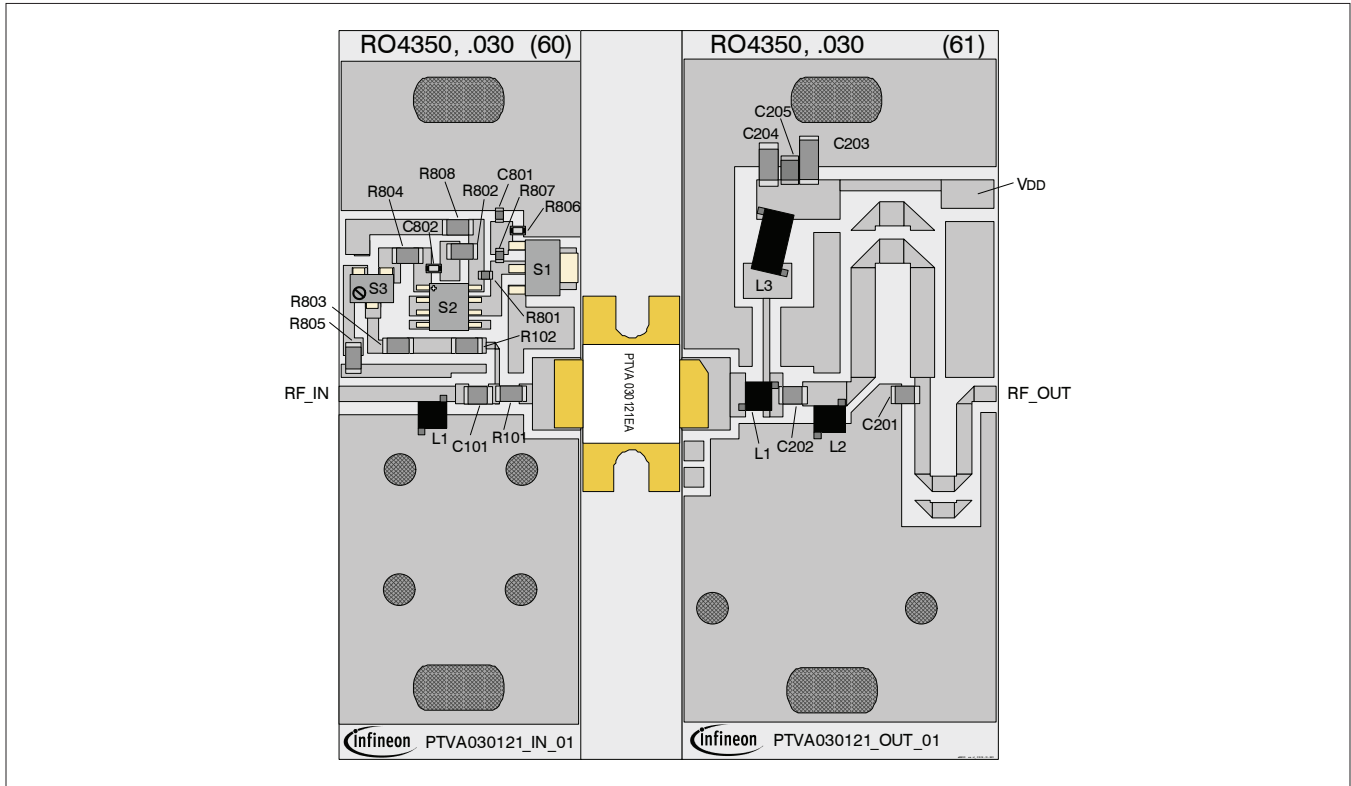

Reference circuit assembly diagram (not to scale)

Component ID	Description	Suggested Supplier	P/N
<b>Input</b>			
C101	Chip capacitor, 300 pF	ATC	ATC100B301JW200XB
C801, C802	Capacitor, 1000 pF	Panasonic Electronic Components	ECJ-1VB1H102K
L1	Inductor, 5 nH	Coilcraft	A02TGLB
R101	Resistor, 2.2 $\Omega$	Panasonic Electronic Components	ERJ-8GEYJ2R2V
R102	Resistor, 1000 $\Omega$	Panasonic Electronic Components	ERJ-8GEYJ102V
R801, R807	Resistor, 1200 $\Omega$	Panasonic Electronic Components	ERJ-3GEYJ122V
R802	Resistor, 6200 $\Omega$	Panasonic Electronic Components	ERJ-8GEYJ622V
R803	Resistor, 10 $\Omega$	Panasonic Electronic Components	ERJ-8GEYJ100V
R804, R805, R808	Resistor, 2000 $\Omega$	Panasonic Electronic Components	ERJ-8GEYJ202V
R806	Resistor, 1300 $\Omega$	Panasonic Electronic Components	ERJ-3GEYJ132V
S1	Transistor	Infineon Technologies	BCP56
S2	Voltage regulator	Fairchild Semiconductor	LM7805CT
S3	Potentiometer, 2K $\Omega$	Bourns Inc.	3224W-1-202E

table continued next page

**Reference Circuit** (cont.)

Component ID	Description	Suggested Supplier	P/N
<b>Output</b>			
C201	Chip capacitor, 9.1 pF	ATC	ATC100B9R1BW500XB
C202	Chip capacitor, 300 pF	ATC	ATC100B301JW200XB
C203	Chip capacitor, 10 $\mu$ F	TDK Corporation	C5750X7S2A106M230KB
C204	Capacitor, 1 $\mu$ F	TDK Corporation	C4532X7R2A105K230KA
C205	Chip capacitor, 300 pF	ATC	ATC100B301JW200XB
L1, L2	Inductor, 8 nH	Coilcraft	A03TGLB
L3	Inductor, 43 nH	Coilcraft	B10TGLB

**See next page for package mechanical specifications**



## Package Outline Specifications

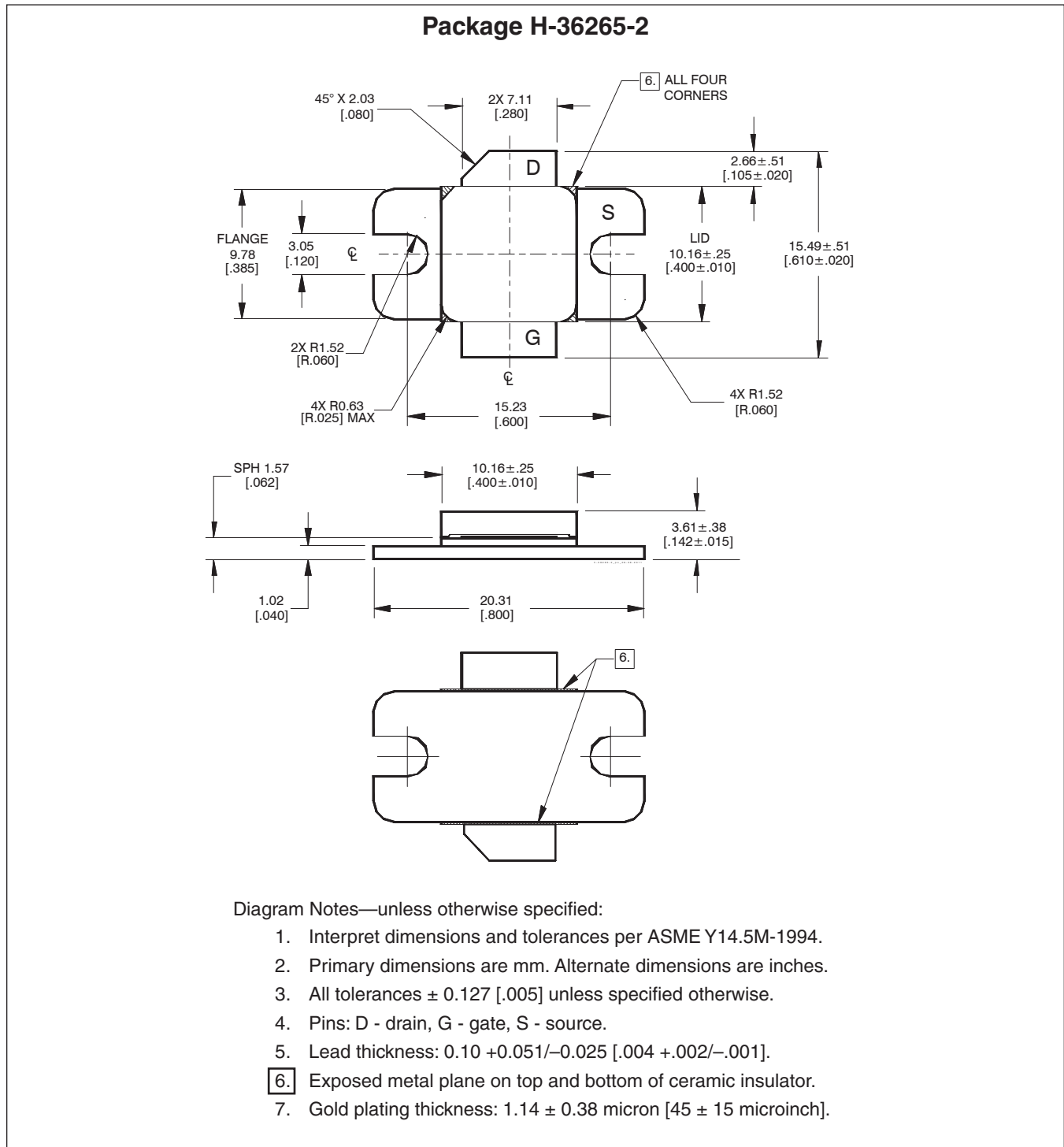

Find the latest and most complete information about products and packaging at the Infineon Internet page [highpowerRF@infineon.com](mailto:highpowerRF@infineon.com)

Revision History: 2016-04-19

Data Sheet

Previous Version: 2013-07-02, Data Sheet

Page	Subjects (major changes since last revision)
1, 2	Added ESD rating, updated ordering information

**We Listen to Your Comments**

Any information within this document that you feel is wrong, unclear or missing at all? Your feedback will help us to continuously improve the quality of this document. Please send your proposal (including a reference to this document) to:

[highpowerRF@infineon.com](mailto:highpowerRF@infineon.com)

To request other information, contact us at:  
+1 877 465 3667 (1-877-GO-LDMOS) USA  
or +1 408 776 0600 International

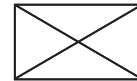

**Edition 2016-04-19**

**Published by  
Infineon Technologies AG  
85579 Neubiberg, Germany**

**© 2010 Infineon Technologies AG  
All Rights Reserved.**

**Legal Disclaimer**

The information given in this document shall in no event be regarded as a guarantee of conditions or characteristics. With respect to any examples or hints given herein, any typical values stated herein and/or any information regarding the application of the device, Infineon Technologies hereby disclaims any and all warranties and liabilities of any kind, including without limitation, warranties of non-infringement of intellectual property rights of any third party.

**Information**

For further information on technology, delivery terms and conditions and prices, please contact the nearest Infineon Technologies Office ([www.infineon.com/rfpower](http://www.infineon.com/rfpower)).

**Warnings**

Due to technical requirements, components may contain dangerous substances. For information on the types in question, please contact the nearest Infineon Technologies Office.

Infineon Technologies components may be used in life-support devices or systems only with the express written approval of Infineon Technologies, if a failure of such components can reasonably be expected to cause the failure of that life-support device or system or to affect the safety or effectiveness of that device or system. Life support devices or systems are intended to be implanted in the human body or to support and/or maintain and sustain and/or protect human life. If they fail, it is reasonable to assume that the health of the user or other persons may be endangered.