

PU SERIES

1W UNREGULATED

DANUBE

FEATURES

- SINGLE IN LINE PACKAGE
- 1W UNREGULATED OUTPUT POWER
- 100% BURN IN
- HIGH EFFICIENCY
- INTERNAL SMD TECHNOLOGY
- NO HEATSINK REQUIRED
- UL 94V-0 PACKAGE MATERIAL
- CUSTOM SOLUTIONS AVAILABLE
- RoHS COMPLIANT
- 3 YEARS WARRANTY



OUTPUT SPECIFICATIONS

Voltage Set-point Accuracy	+/-2% max
Temperature Coefficient	+/-0.05%/°C
Ripple & Noise(20MHz BW)	100mVp-p max
Line Regulation ¹	+/-1.2% max
Load Regulation ²	+/-8% max
Minimum Load	20% of Full Load
Short Circuit Protection	Momentary

INPUT SPECIFICATIONS

Input Voltage Range	+/-10% max
Input Filter	Capacitor Typ
Input Reflected Ripple Current	50mA _{p-p} max
Protection	Fuse Recommended

GENERAL SPECIFICATIONS

Efficiency	70%-83%
Isolation Voltage ³	
Single/Dual	1500-3000 VDC min
Twin	In to Out 1000 VDC min
	Out to Out 500 VDC min
Isolation Resistance	10 ⁹ ohms min
Isolation Capacitance	80pF max
Switching Frequency	100KHz min
MTBF ⁴	>2,000,000 Hours
Weight	2.1g Typ
Case Material	Non-Conductive Plastic
Case Size	19.6mm*6.1mm*10.2mm
	19.6mm*7.1mm*10.2mm
Conducted Emissions	EN55022 Class A
Radiated Emissions	EN55022 Class A

ENVIRONMENTAL SPECIFICATIONS

Operating Temperature	-40°C to +71°C
Storage Temperature	-55°C to +125°C
Humidity	95% max
Cooling	Free-Air Convection

ALL SPECIFICATIONS TYPICAL AT NOMINAL LINE, FULL LOAD AND 25°C UNLESS OTHERWISE NOTED.

¹ Line Regulation is for a 1.0% change in input Voltage.

² Load Regulation is for output load current change from 20% to 100%.

³ 1500VDC for 10 seconds, 3000VDC for 3 seconds.

⁴ MIL-HDBK-217F @25 °C , Ground Benign.

● **SELECTION GUIDE(1)**
1W 1500VDC ISOLATION

MODEL NUMBER	INPUT VOLTAGE (VDC)	OUTPUT VOLTAGE (VDC)	OUTPUT CURRENT (mA)	INPUT ⁵ CURRENT(mA)		EFF (%) ⁶	ISOLATION (VDC)	PACKAGE
				FULL LOAD	NO LOAD			
				PUS-0503.3(A or B)	5			
PUS-0505(A or B or E)	5	5	200	283	35	71	1500	A or B or E
PUS-0509(A or B or E)	5	9	111	257	34	78	1500	A or B or E
PUS-0512(A or B or E)	5	12	84	253	33	79	1500	A or B or E
PUS-0515(A or B or E)	5	15	67	253	34	79	1500	A or B or E
PUD-0505(A or B)	5	+/-5	+/-100	278	35	72	1500	A or B
PUD-0509(A or B)	5	+/-9	+/-56	260	34	77	1500	A or B
PUD-0512(A or B)	5	+/-12	+/-42	253	33	79	1500	A or B
PUD-0515(A or B)	5	+/-15	+/-34	260	34	77	1500	A or B
PUS-0909(A or B)	9	9	111	148	24	75	1500	A or B
PUS-1203.3(A or B)	12	3.3	300	112	14	74	1500	A or B
PUS-1205(A or B or E)	12	5	200	112	15	74	1500	A or B or E
PUS-1209(A or B or E)	12	9	111	107	14	78	1500	A or B or E
PUS-1212(A or B or E)	12	12	84	102	14	82	1500	A or B or E
PUS-1215(A or B or E)	12	15	67	102	14	82	1500	A or B or E
PUD-1205(A or B)	12	+/-5	+/-100	112	15	74	1500	A or B
PUD-1212(A or B)	12	+/-12	+/-42	105	14	79	1500	A or B
PUD-1215(A or B)	12	+/-15	+/-34	101	15	83	1500	A or B
PUS-2403.3C	24	3.3	300	57	9	73	1500	C
PUS-2405C	24	5	200	57	9	73	1500	C
PUS-2409C	24	9	111	56	9	75	1500	C
PUS-2412C	24	12	84	54	9	77	1500	C
PUS-2415C	24	15	67	52	10	80	1500	C
PUS-2424C	24	24	42	54	9	77	1500	C
PUD-2405C	24	+/-5	+/-100	57	10	73	1500	C
PUD-2412C	24	+/-12	+/-42	54	10	77	1500	C
PUD-2415C	24	+/-15	+/-34	52	9	80	1500	C

Note: Other input to output voltages may be available. Please contact factory.

ORDERING INFORMATION:

FOR EXAMPLE: PUS-****A(SINGLE OUTPUT A PACKAGE)

PUD-****A(DUAL OUTPUT A PACKAGE)

PUS-****B(SINGLE OUTPUT B PACKAGE)

PUD-****B(DUAL OUTPUT B PACKAGE)

⁵ NOMINAL INPUT VOLTAGE.

⁶ NOMINAL INPUT VOLTAGE, FULL LOAD.

● **SELECTION GUIDE(2)**
1W 1500VDC ISOLATION

MODEL NUMBER	INPUT VOLTAGE (VDC)	OUTPUT VOLTAGE (VDC)	OUTPUT CURRENT (mA)	INPUT ⁷		EFF (%) ⁸	ISOLATION (VDC)	PACKAGE
				CURRENT(mA)				
				FULL LOAD	NO LOAD			
PUS-0503.3AY	5	3.3	300	274	34	73	1500	AY
PUS-0505AY	5	5	200	283	34	71	1500	AY
PUS-0509AY	5	9	111	257	35	78	1500	AY
PUS-0512AY	5	12	84	253	34	79	1500	AY
PUS-0515AY	5	15	67	253	35	79	1500	AY
PUD-0505AY	5	+/-5	+/-100	278	35	72	1500	AY
PUD-0512AY	5	+/-12	+/-42	253	33	79	1500	AY
PUD-0515AY	5	+/-15	+/-34	260	34	77	1500	AY
PUS-0909AY	9	9	111	148	24	75	1500	AY
PUS-1203.3AY	12	3.3	300	112	14	74	1500	AY
PUS-1205AY	12	5	200	112	14	74	1500	AY
PUS-1209AY	12	9	111	107	15	78	1500	AY
PUS-1212AY	12	12	84	102	13	82	1500	AY
PUS-1215AY	12	15	67	102	14	82	1500	AY
PUD-1205AY	12	+/-5	+/-100	112	15	74	1500	AY
PUD-1212AY	12	+/-12	+/-42	105	14	79	1500	AY
PUD-1215AY	12	+/-15	+/-34	101	14	83	1500	AY
PUS-2403.3CY	24	3.3	300	57	10	73	1500	CY
PUS-2405CY	24	5	200	57	10	73	1500	CY
PUS-2409CY	24	9	111	56	9	75	1500	CY
PUS-2412CY	24	12	84	54	10	77	1500	CY
PUS-2415CY	24	15	67	52	9	80	1500	CY
PUS-2424CY	24	24	42	54	9	77	1500	CY
PUD-2405CY	24	+/-5	+/-100	57	10	73	1500	CY
PUD-2412CY	24	+/-12	+/-42	54	9	77	1500	CY
PUD-2415CY	24	+/-15	+/-34	52	9	80	1500	CY

Note: Other input to output voltages may be available. Please contact factory.

ORDERING INFORMATION:

FOR EXAMPLE: PUS-**AY(SINGLE OUTPUT AY PACKAGE)**

PUD-**AY(DUAL OUTPUT AY PACKAGE)**

PUS-**CY(SINGLE OUTPUT CY PACKAGE)**

PUD-**CY(DUAL OUTPUT CY PACKAGE)**

⁷ NOMINAL INPUT VOLTAGE.

⁸ NOMINAL INPUT VOLTAGE, FULL LOAD.

● **SELECTION GUIDE(3)**
1W DUAL SEPARATE OUTPUT

MODEL NUMBER	INPUT VOLTAGE (VDC)	OUTPUT VOLTAGE (VDC)		OUTPUT CURRENT (mA)		INPUT ⁹ CURRENT(mA)		EFF (%) ¹⁰	ISOLATION (VDC)	PACKAGE
		OUT1	OUT2	OUT1	OUT2	FULL LOAD	NO LOAD			
PUD-050503.3	5	+5	+3.3	+100	+152	286	34	70	1500	F
PUD-050505	5	+5	+5	+100	+100	255	34	78	1500	F
PUD-050509	5	+5	+9	+100	+56	251	33	80	1500	F
PUD-050512	5	+5	+12	+100	+42	250	35	80	1500	F
PUD-050515	5	+5	+15	+100	+34	250	35	80	1500	F
PUD-120505	12	+5	+5	+100	+100	119	15	70	1500	F
PUD-120509	12	+5	+9	+100	+56	104	14	80	1500	F
PUD-120512	12	+5	+12	+100	+42	102	14	82	1500	F
PUD-120515	12	+5	+15	+100	+34	104	14	80	1500	F
PUD-2403.303.3	24	+3.3	+3.3	+152	+152	60	11	70	1500	F
PUD-240505	24	+5	+5	+100	+100	60	11	70	1500	F
PUD-241212	24	+12	+12	+41	+41	52	10	80	1500	F

Note: Other input to output voltages may be available. Please contact factory.

ORDERING INFORMATION:

FOR EXAMPLE: PUD-*** (TWIN OUTPUT F PACKAGE)**

⁹ NOMINAL INPUT VOLTAGE.

¹⁰ NOMINAL INPUT VOLTAGE, FULL LOAD.

● **SELECTION GUIDE(4)**
1W 3000VDC ISOLATION

MODEL NUMBER	INPUT VOLTAGE (VDC)	OUTPUT VOLTAGE (VDC)	OUTPUT CURRENT (mA)	INPUT ¹¹		EFF (%) ¹²	ISOLATION (VDC)	PACKAGE
				CURRENT(mA)				
				FULL LOAD	NO LOAD			
PUS-03.305-3K	3.3	5	200	378	35	80	3000	D
PUS-0503.3-3K	5	3.3	300	274	35	73	3000	B
PUS-0505-3K	5	5	200	283	34	71	3000	B
PUS-0509-3K	5	9	111	257	34	78	3000	B
PUS-0512-3K	5	12	84	255	34	78	3000	B
PUS-0515-3K	5	15	67	253	35	79	3000	B
PUD-0505-3K	5	+/-5	+/-100	274	35	73	3000	B
PUD-0512-3K	5	+/-12	+/-42	253	35	79	3000	B
PUD-0515-3K	5	+/-15	+/-34	253	34	79	3000	B
PUS-1203.3-3K	12	3.3	300	112	14	74	3000	B
PUS-1205-3K	12	5	200	112	14	74	3000	B
PUS-1209-3K	12	9	111	107	15	78	3000	B
PUS-1212-3K	12	12	84	102	13	82	3000	B
PUS-1215-3K	12	15	67	103	14	81	3000	B
PUD-1205-3K	12	+/-5	+/-100	112	14	74	3000	B
PUD-1212-3K	12	+/-12	+/-42	101	15	83	3000	B
PUD-1215-3K	12	+/-15	+/-34	101	14	83	3000	B
PUS-2403.3-3K	24	3.3	300	57	10	73	3000	D
PUS-2405-3K	24	5	200	57	10	73	3000	D
PUS-2409-3K	24	9	111	56	10	75	3000	D
PUS-2412-3K	24	12	84	54	10	77	3000	D
PUS-2415-3K	24	15	67	52	9	80	3000	D
PUD-2405-3K	24	+/-5	+/-100	57	10	73	3000	D
PUD-2412-3K	24	+/-12	+/-42	54	9	77	3000	D
PUD-2415-3K	24	+/-15	+/-34	52	10	80	3000	D

Note: Other input to output voltages may be available. Please contact factory.

ORDERING INFORMATION:

FOR EXAMPLE: PUS-**-3K(SINGLE OUTPUT 3000V ISOLATION)**

PUD-**-3K(DUAL OUTPUT 3000V ISOLATION)**

¹¹ NOMINAL INPUT VOLTAGE.

¹² NOMINAL INPUT VOLTAGE, FULL LOAD.

MECHANICAL DIMENSIONS & RECOMMENDED FOOTPRINT DETAILS

PACKAGE "A"

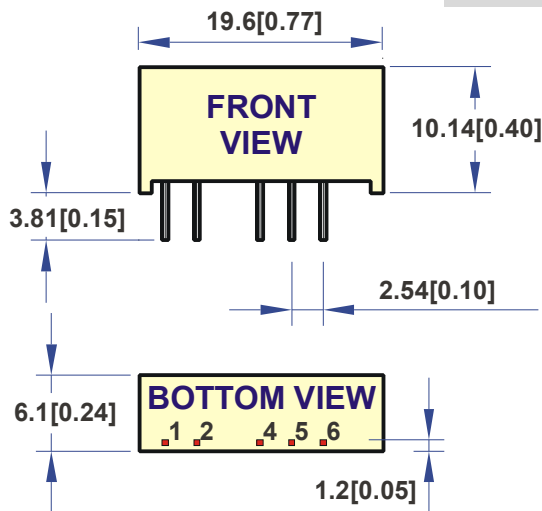

PIN	SINGLE	DUAL
1	+Vin	+Vin
2	-Vin	-Vin
4	-Vout	-Vout
5	NP	COMMON
6	+Vout	+Vout

NOTE : All Dimensions In mm(Inches)

1. Pin Size is 0.50x0.30mm[0.02x0.01"]

2. Pin is Tolerance .XX= ±0.05mm

3. Tolerance .X or .XX= ±0.5mm

All dimensions are in mm[inches]

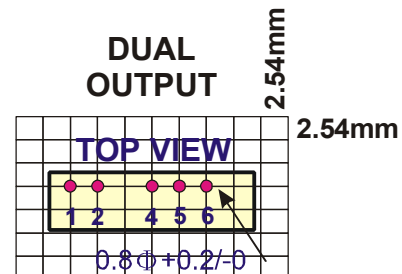
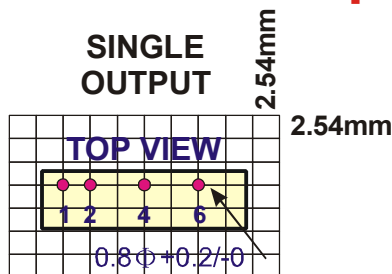

PACKAGE "B"

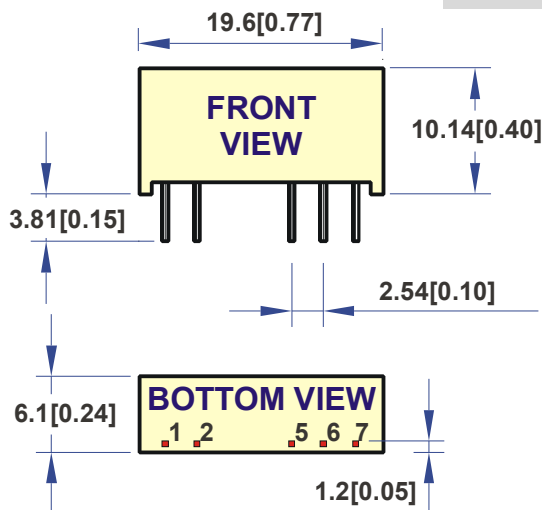

PIN	SINGLE	DUAL
1	+Vin	+Vin
2	-Vin	-Vin
5	-Vout	-Vout
6	NP	COMMON
7	+Vout	+Vout

NOTE : All Dimensions In mm(Inches)

1. Pin Size is 0.50x0.30mm[0.02x0.01"]

2. Pin is Tolerance .XX= ±0.05mm

3. Tolerance .X or .XX= ±0.5mm

All dimensions are in mm[inches]

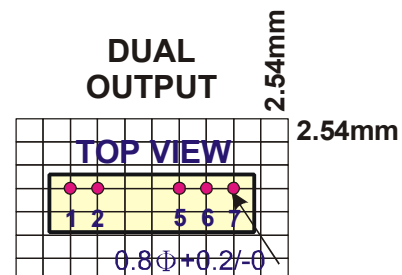
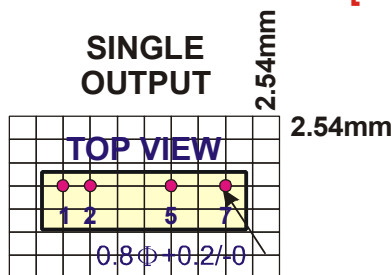

PACKAGE "C"

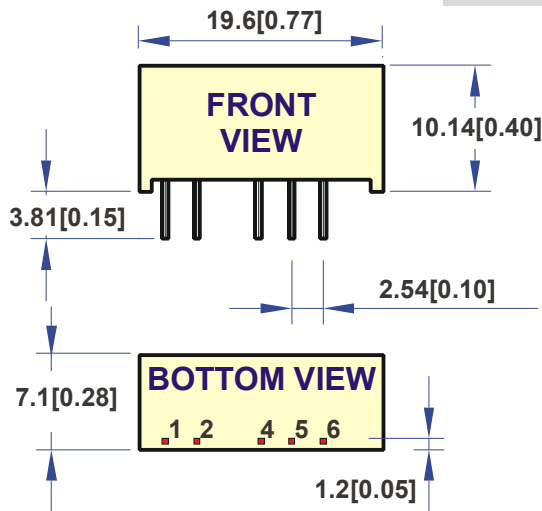

PIN	SINGLE	DUAL
1	+Vin	+Vin
2	-Vin	-Vin
4	-Vout	-Vout
5	NP	COMMON
6	+Vout	+Vout

NOTE : All Dimensions In mm(Inches)

1. Pin Size is 0.50x0.30mm[0.02x0.01"]
2. Pin is Tolerance .XX= ±0.05mm
3. Tolerance .X or .XX= ±0.5mm

All dimensions are in mm[inches]

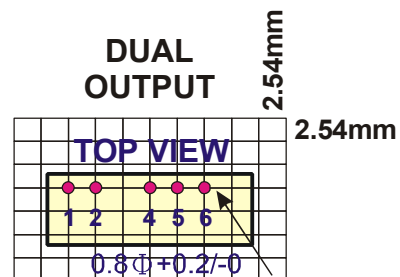
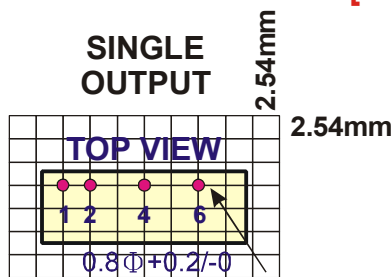

PACKAGE "D"

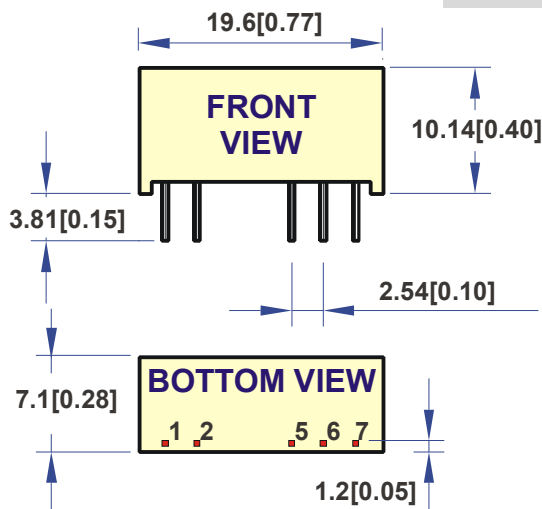

PIN	SINGLE	DUAL
1	+Vin	+Vin
2	-Vin	-Vin
5	-Vout	-Vout
6	NP	COMMON
7	+Vout	+Vout

NOTE : All Dimensions In mm(Inches)

1. Pin Size is 0.50x0.30mm[0.02x0.01"]
2. Pin is Tolerance .XX= ±0.05mm
3. Tolerance .X or .XX= ±0.5mm

All dimensions are in mm[inches]

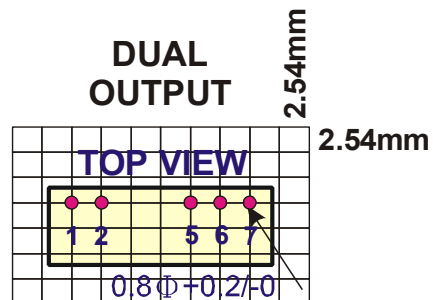
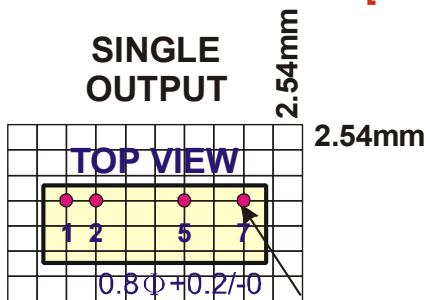

PACKAGE "E"

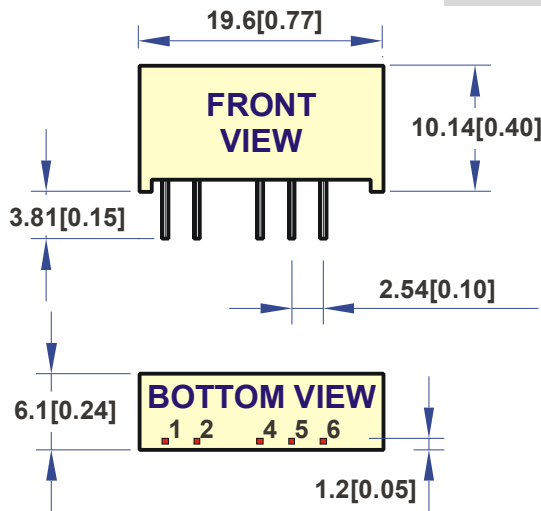

PIN	SINGLE
1	+Vin
2	-Vin
4	NP
5	-Vout
6	+Vout

NOTE : All Dimensions In mm(Inches)

1. Pin Size is 0.50x0.30mm[0.02x0.01"]
2. Pin is Tolerance .XX= ±0.05mm
3. Tolerance .X or .XX= ±0.5mm

All dimensions are in mm[inches]

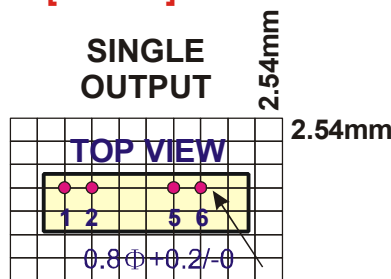

PACKAGE "F"

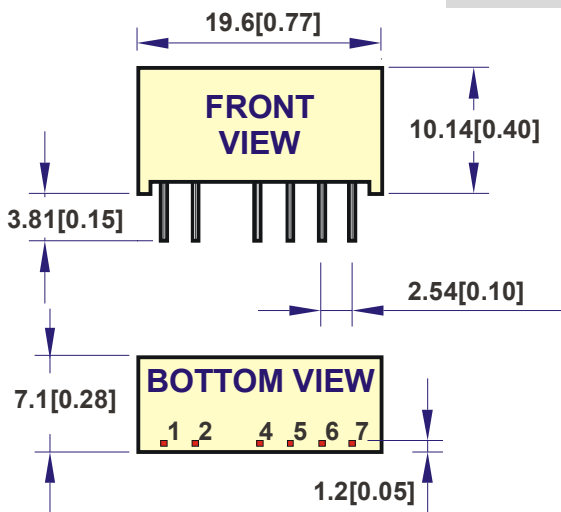

PIN	TWIN
1	+Vin
2	-Vin
4	+5V / Vout 1
5	- 5V / Vout 1
6	+ Vout 2
7	- Vout 2

NOTE : All Dimensions In mm(Inches)

1. Pin Size is 0.50x0.30mm[0.02x0.01"]
2. Pin is Tolerance .XX= ±0.05mm
3. Tolerance .X or .XX= ±0.5mm

All dimensions are in mm[inches]

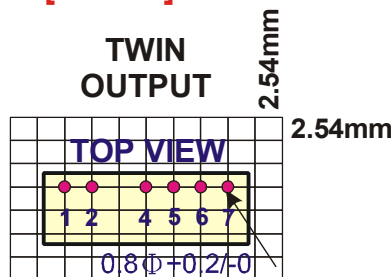

PACKAGE "AY"

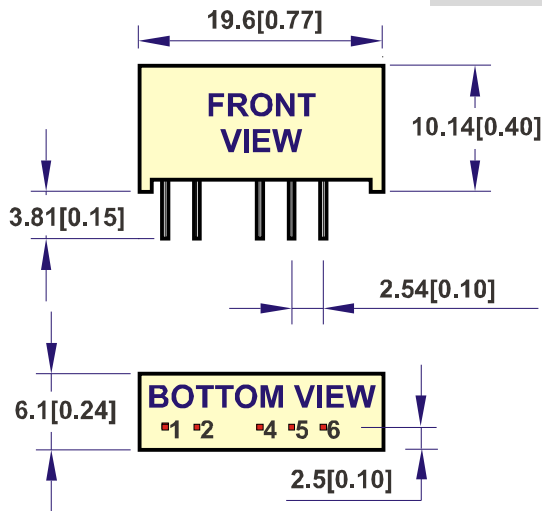

PIN	SINGLE	DUAL
1	+Vin	+Vin
2	-Vin	-Vin
4	-Vout	-Vout
5	NP	COMMON
6	+Vout	+Vout

NOTE : All Dimensions In mm(Inches)

1. Pin Size is 0.50x0.30mm[0.02x0.01"]
2. Pin is Tolerance .XX= ±0.05mm
3. Tolerance .X or .XX= ±0.5mm

All dimensions are in mm[inches]

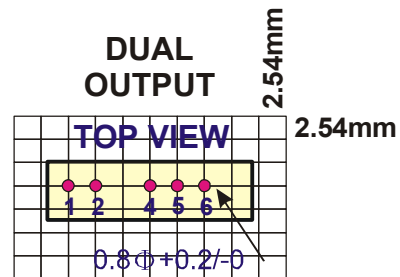
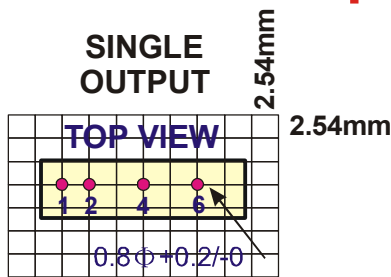

PACKAGE "CY"

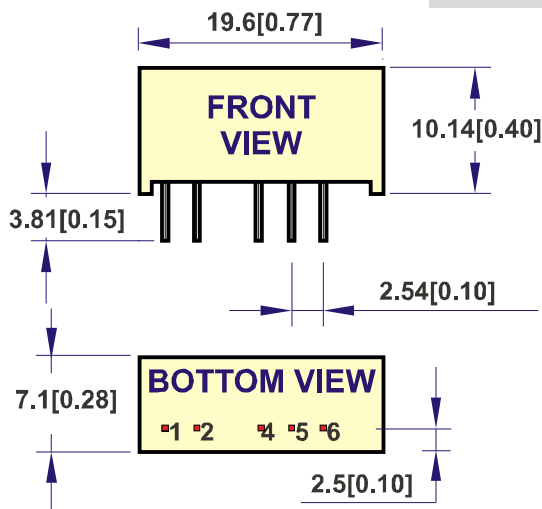

PIN	SINGLE	DUAL
1	+Vin	+Vin
2	-Vin	-Vin
4	-Vout	-Vout
5	NP	COMMON
6	+Vout	+Vout

NOTE : All Dimensions In mm(Inches)

1. Pin Size is 0.50x0.30mm[0.02x0.01"]
2. Pin is Tolerance .XX= ±0.05mm
3. Tolerance .X or .XX= ±0.5mm

All dimensions are in mm[inches]

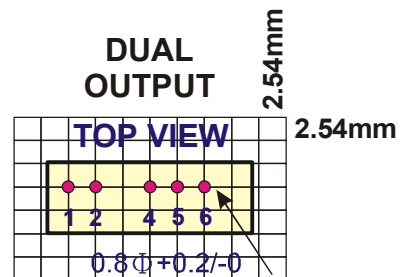
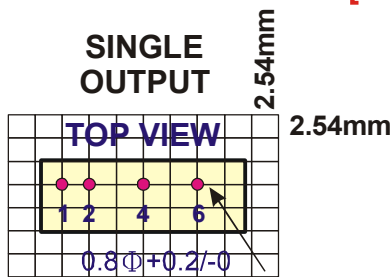

● SIMPLIFIED SCHEMATIC

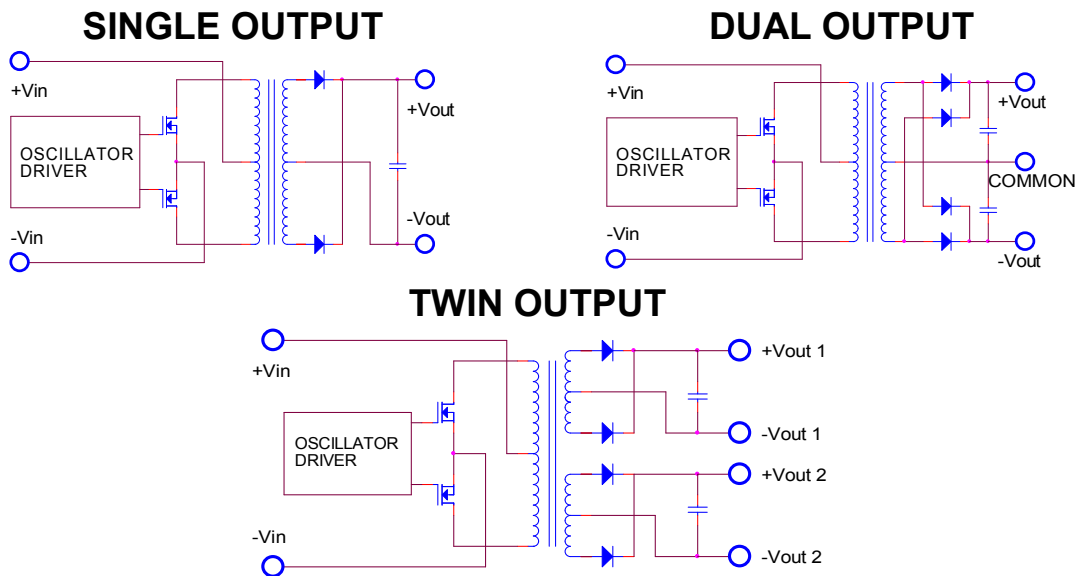

● TYPICAL APPLICATIONS

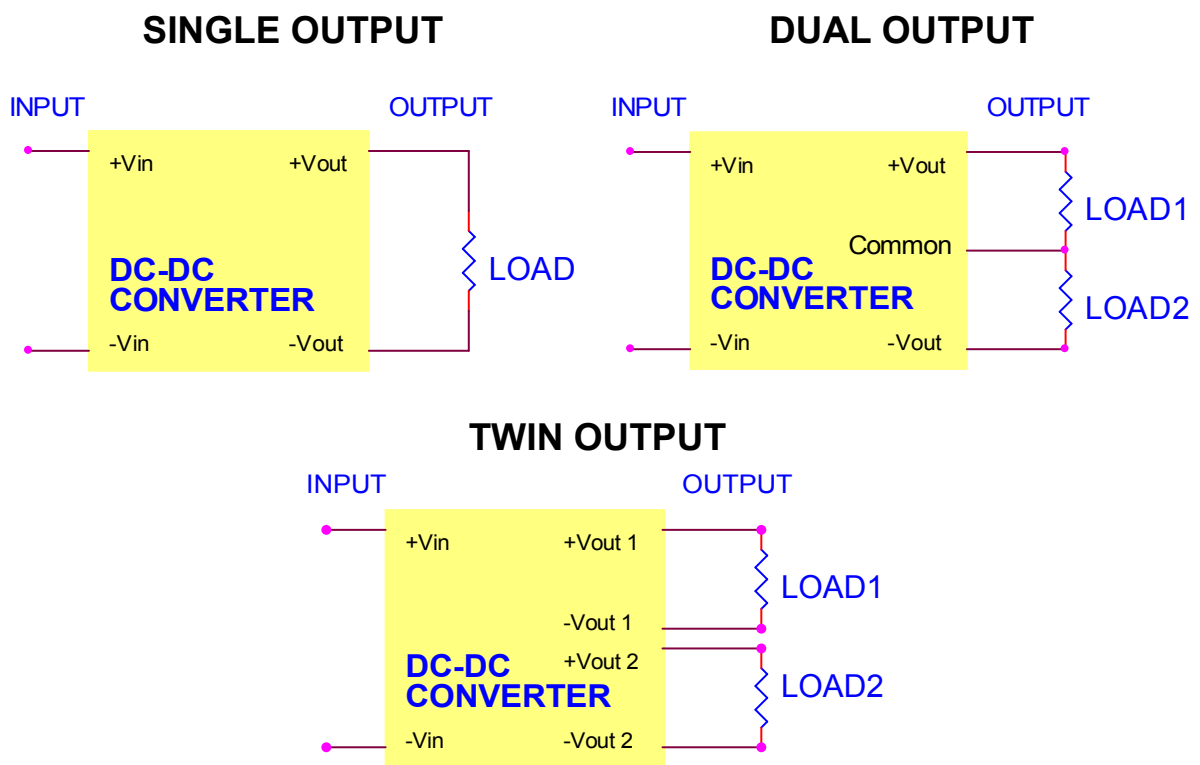

● TYPICAL PERFORMANCE CURVES

Specifications typical at TA=25°C, nominal input voltage, rated output current unless otherwise specified.

VOUT VS LOAD(3.3Vout Models)

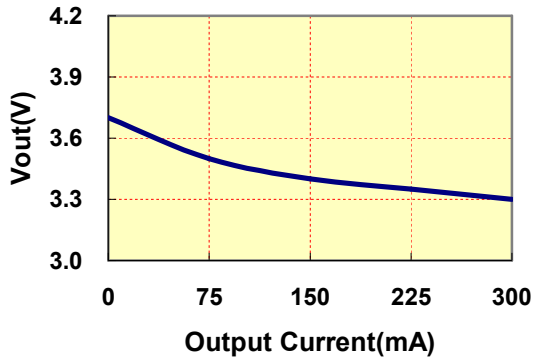

VOUT VS LOAD(5Vout Models)

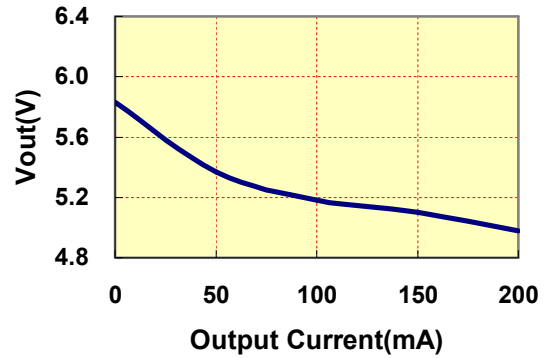

VOUT VS LOAD(+/-5Vout Models)

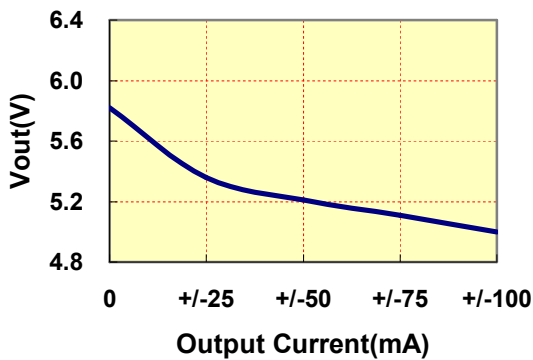

VOUT VS LOAD(9Vout Models)

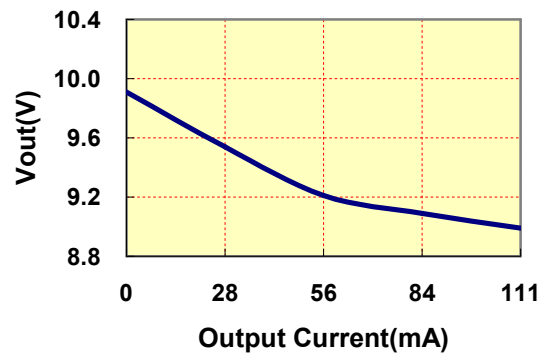

VOUT VS LOAD(12Vout Models)

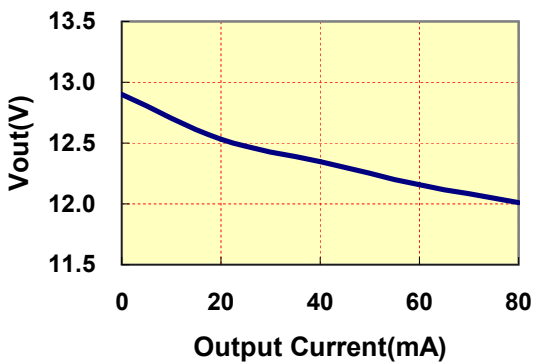

VOUT VS LOAD(+/- 12Vout Models)

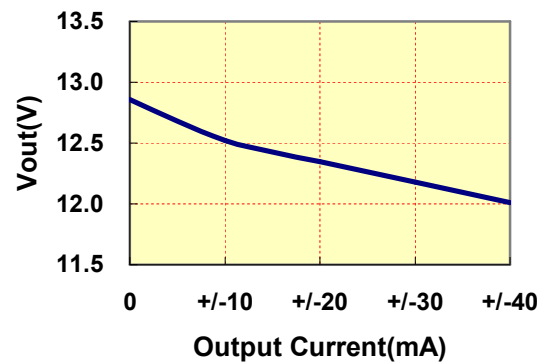

VOUT VS LOAD(15Vout Models)

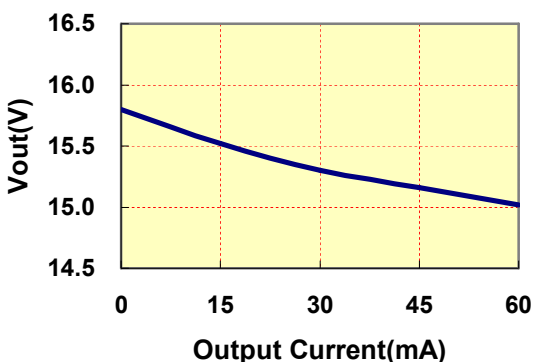

VOUT VS LOAD(+/- 15Vout Models)

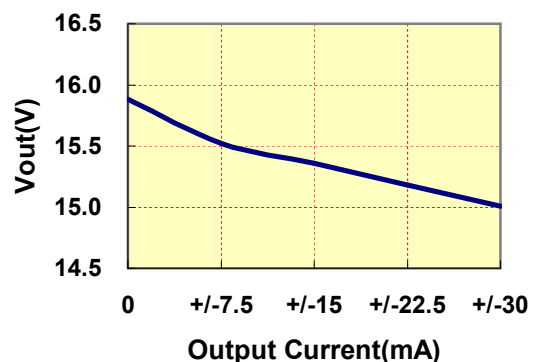

DERATING CURVE

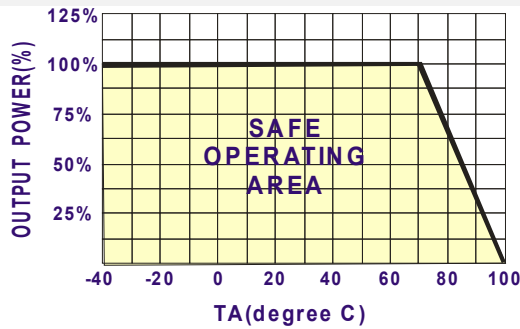

EFFICIENCY VS LOAD

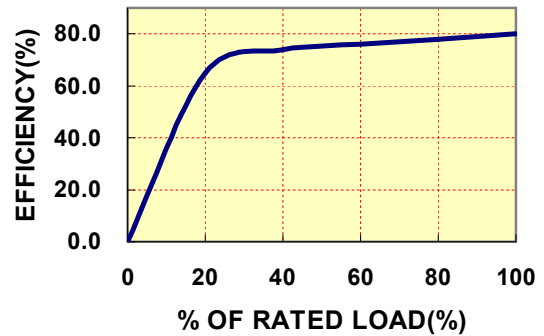

● INPUT FUSE SELECTION GUIDE

4.5-5.5V INPUT VOLTAGE(VDC)	10.8-13.2V INPUT VOLTAGE(VDC)	21.6-26.4V INPUT VOLTAGE(VDC)
800mA Slow-Blow Type	300mA Slow-Blow Type	150mA Slow-Blow Type

Note: Certain applications may require the installation of external fuse in front of the input.

PU SERIES APPLICATION NOTES:

EXTERNAL CAPACITANCE REQUIREMENTS:

Output filtering is required for operation. A minimum of 10uF is needed. Output capacitance may be increased for additional filtering, not to exceed 220uF.

To meet the reflected ripple requirements of the converter, an input impedance of less than 0.5ohm from DC to 250KHz is required.

We Can Offer EMC-Filter According To EN55011/22 Class B.

Negative Outputs:

A negative output voltage may be obtained by connecting the +OUT to circuit ground and connecting -OUT as the negative output.

FOR MORE INFORMATION CALL:

Danube Enterprise Co., Ltd.

Tel: 886-7-3755165

Fax: 886-7-3755330

E-mail: danube@ms10.hinet.net

Home Page

<http://www.danube.com.tw>
