

PWR-SMP210

PWM Power Supply IC

85-265 VAC Input

Isolated, Regulated DC Output



Product Highlights

Integrated Power Switch and CMOS Controller

- Output power up to 10 W from rectified 220 VAC input, 5 W from rectified universal (85 to 265 VAC) input
- Integrated solution minimizes overall size
- External transformer provides isolation and selectable output voltages

High-voltage, Low-capacitance MOSFET Output

- Designed for 120/220 V off-line applications
- Can also be used with DC inputs from 36 V to 400 V
- Low capacitance allows for high frequency operation

High-speed Voltage-mode PWM Controller

- Internal pre-regulator self-powers the IC on start-up
- High PWM frequency reduces component size
- Minimum external parts required

Built-In Self-protection Circuits

- Cycle-by-cycle Current Limit
- Input undervoltage lockout
- Thermal shutdown

Description

The PWR-SMP210, intended for 220 V or universal off-line isolated power supply applications, combines a high voltage power MOSFET switch with a switchmode power system controller in a monolithic integrated circuit. Few external components are required to implement a low-cost, isolated, off-line power supply. High frequency operation reduces total power supply size.

The power MOSFET switch features include high voltage, low $R_{DS(ON)}$, low capacitance, and low gate threshold voltage. The combination of lower capacitance and lower gate threshold voltage results in a tenfold reduction in gate drive power. Lower capacitances also facilitate higher frequency operation.

The controller section of the PWR-SMP210 contains all the blocks required to drive and control the power stage: off-line pre-regulator, oscillator, bandgap reference, error amplifier, gate driver, and circuit protection. This voltage-mode Pulse Width Modulation control circuit is optimized for flyback topologies, but may be used with other topologies as well.

The PWR-SMP210 is available in a 16-pin plastic batwing DIP or 20-pin batwing SOIC package.

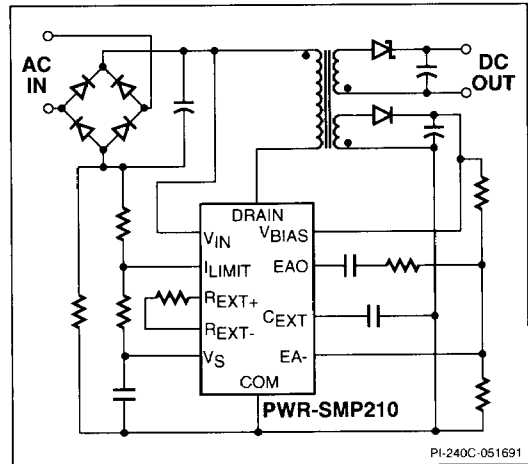

Figure 1. Typical Application

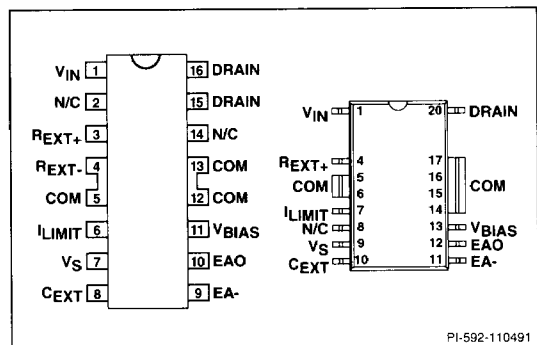

Figure 2. Pin Configuration

ORDERING INFORMATION

PART NUMBER	PACKAGE	TEMP RANGE
PWR-SMP210BNC	16-pin PWR PDIP	0 to 70°C
PWR-SMP210BNI	16-pin PWR PDIP	-40 to 85°C
PWR-SMP210SRI	20-pin PWR SOIC	-40 to 85°C



Pin Functional Description

(Pin Number in Parenthesis is for SOIC Version)

Pin 1(1):

High voltage V_{IN} for connection to the high voltage pre-regulator used to self-power the device during start-up.

Pin 2:

N/C for creepage distance.

Pin 3(4):

A resistor placed between R_{EXT+} and R_{EXT-} sets the internal bias currents.

Pin 4(5, 6):

R_{EXT-} is the return for the reference current. Do not connect to ground plane.

Pin 5, 12, 13(14, 15, 16, 17):

COM connections. Ground or reference point for the circuit.

Pin 6(7):

I_{LIMIT} is used with an external resistor divider provide protection of the output MOSFET from excessive current.

Pin 7(9):

Connection for a bypass capacitor for the internally generated V_s supply.

Pin 8(10):

C_{EXT} is used to set the oscillator frequency. Adding external capacitance lowers the PWM frequency.

Pin 9(11):

EA- is the error amplifier inverting input for connection to the external feedback and compensation networks.

Pin 10(12):

EAO is the error amplifier output for connection to the external compensation network.

Pin 11(13):

V_{BIAS} is the feedback voltage used to self-power the device once the supply is operating.

Pin 14:

N/C for creepage distance.

Pin 15, 16(20):

Open DRAIN of the output MOSFET. Both pins must be externally connected.

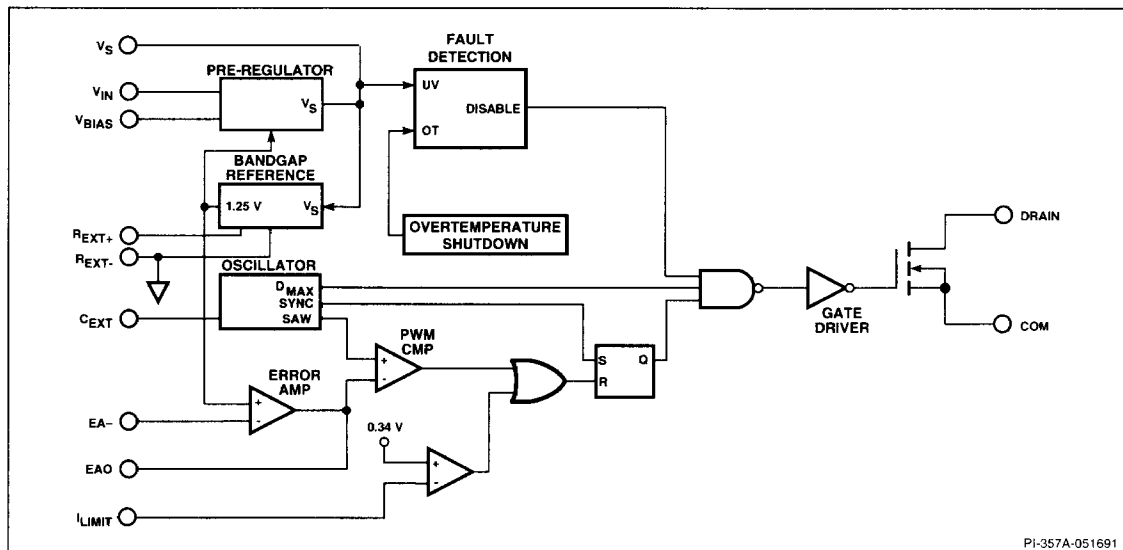

PI-357A-051691

Figure 3. Functional Block Diagram of the PWR-SMP210.



PWR-SMP210 Functional Description

Pre-regulator and On-board Voltages

The pre-regulator provides the bias current required by the controller and driver circuitry. The pre-regulator consists of a high voltage MOSFET, a gate bias current source, and an error amplifier. The error amplifier regulates V_S to approximately 5.6 volts by controlling the gate of the MOSFET.

The pre-regulator MOSFET dissipates significant amounts of power when supplying bias current. This dissipation is eliminated when the feedback winding and filter drives the V_{BIAS} pin above 8.25 volts. The pre-regulator is then cut off and internal bias current is supplied by the feedback circuit connected to V_{BIAS} .

V_S is the supply voltage for the controller and driver circuitry. An external bypass capacitor connected to V_S is required for filtering and reducing noise. The value of V_S also determines when the internal undervoltage lockout is enabled. Undervoltage lockout is maintained whenever V_S is less than 5 V.

Band Gap Reference

V_{REF} is the 1.25 V reference voltage generated by the temperature compensated bandgap reference and buffer. This voltage is used for setting thresholds for the error amplifier, over temperature circuit, and current limit circuit.

Oscillator

The oscillator is completely self-contained. An internal capacitor is alternately charged and discharged by switched constant current sources. The oscillator frequency can be lowered by adding additional capacitance at the C_{EXT} pin.

The voltage switch points are determined by hysteresis built into a comparator. The period of the waveform is determined by values of the current sources which set the rising and falling slopes of the sawtooth waveform. Maximum duty cycle is equal to the ratio of the charge time to the period. Clock and blanking signals are synthesized from the comparator output for use by the modulator.

Error Amplifier

The error amplifier consists of a high performance operational amplifier with the non-inverting input connected to the internal bandgap reference voltage. The output of the error amplifier directly controls the duty cycle of the power switch.

The error amplifier output pin EAO is buffered so that external loads will not affect its output. The buffer has an offset voltage of around 2 V, and an output impedance of around 1.5 k Ω .

Pulse Width Modulator

The pulse width modulator implements a voltage-mode control loop, and generates the digital driver signal which controls the power switch. The duty cycle of the driver signal will change as a function of input voltage and load. Increasing the duty cycle causes the power supply output voltage to go up. Conversely, decreasing the duty cycle causes the output voltage to go down. The pulse width modulator compares the control voltage (error amplifier output) with the sawtooth voltage generated by the oscillator to produce the required duty cycle.

Current Limit Protection

The I_{LIMIT} signal latches off the power switch when the voltage on this pin drops below its threshold. The DRAIN current is sensed by an external resistor. A voltage divider between the V_S voltage and the current sense resistor biases the I_{LIMIT} signal more positive than its threshold voltage. When current is flowing in the current sense resistor, the voltage on the I_{LIMIT} pin will decrease. If the voltage on the I_{LIMIT} pin is below the threshold for longer than the delay time, the power switch will be latched off until the beginning of the next clock cycle.

Overtemperature Protection

Temperature protection is provided by a precision analog circuit that turns the power switch off when the junction gets too hot (typically 135°C). The device will automatically reset and turn back on again when the junction has cooled past the hysteresis temperature level.

5 W Universal Off-line Power Supply with Feedback Winding Regulation

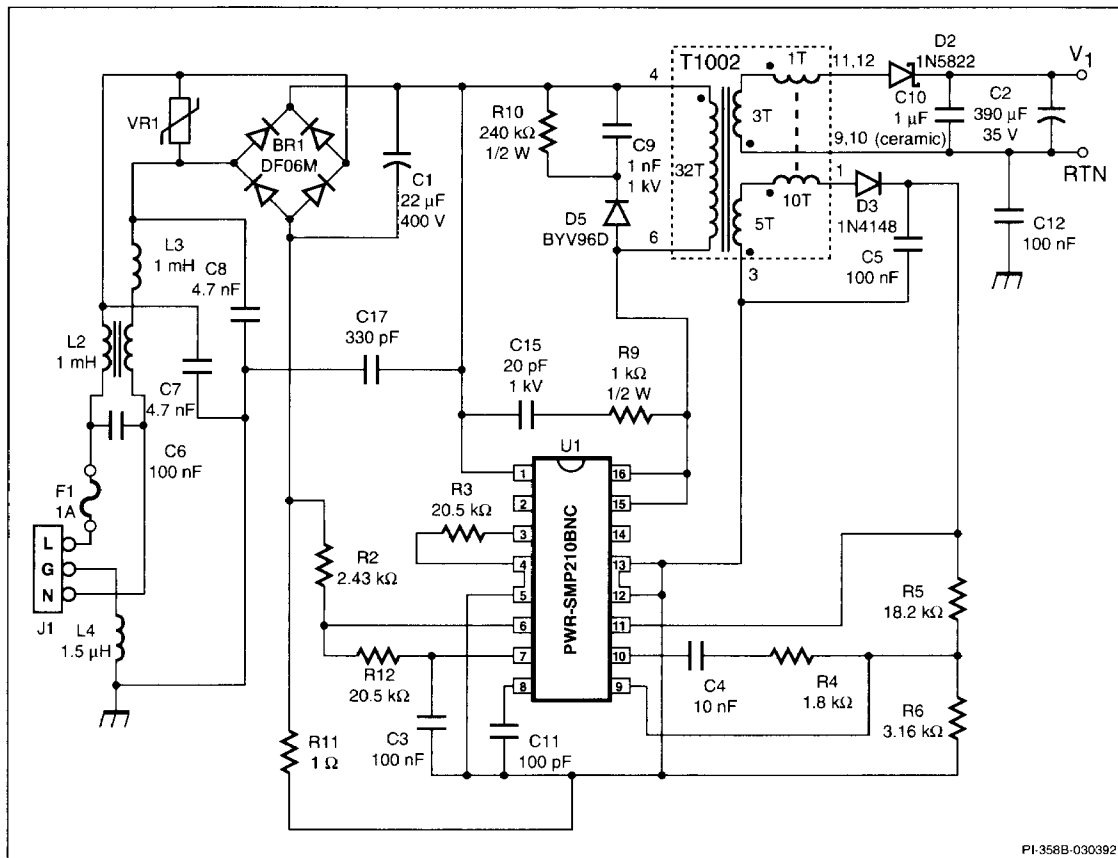

PI-358B-030392

Figure 4. Schematic Diagram of a 5 V, 5 W Universal Input Power Supply Utilizing the PWR-SMP210. For Improved Regulation, use the Optical Feedback Circuit Shown in AN-8.

General Circuit Operation

The flyback power supply circuit shown in Figure 4, when operated with the T1002 standard transformer (see DA-3), will produce a 5 volt, 5 watt power supply that will operate from 85 to 265 V(rms) AC input voltage. The output voltage is selected by the turns ratio of the output winding to the feedback winding. The PWR-SMP210 has been designed for a feedback voltage (pin 11) of 8.5 volts. The effective turns ratio can be fine-tuned if necessary by the number of junctions in D3. Three elements affect the regulation of the output voltage; maintaining a constant feedback winding

voltage, tight coupling of the power transformer, and the use of a pulse transformer to cancel the leakage inductance voltage spike.

L2, L3, L4, C6, C7, C8, C12 and C17 form an EMI filter. BR1 and C1 convert the AC input voltage to rectified DC voltage and provide the cycle-to-cycle hold-up time. D5, C9, and R10 make up a voltage clamping circuit to limit the peak voltage on the drain of the switching transistor. C15 and R9 damps the leakage inductance ringing voltage. The damping network improves the regulation of the

output voltage. R5 and R6 set the feedback voltage to 8.5 volts. R4, R5, C2, C4, and T1 determine the control loop frequency response. R3 sets the current sources within the PWR-SMP210. C11 sets the frequency of operation. If no capacitor is connected to pin 8, the internal capacitor will set the frequency to approximately 850kHz. C3 and C5 are bypass capacitors. R2, R11, and R12 form the cycle-by-cycle current limit circuitry. These values provide maximum power output while maintaining short circuit protection.



General Circuit Operation (cont.)

To achieve full output power and reliable operation of the PWR-SMP210, both DRAIN connections on the batwing DIP package (pin 15 and 16) must be connected together at the printed circuit board. Pin 15 and 16 are not connected within the package.

This circuit uses a secondary winding to monitor and regulate the output voltage. This technique can provide regulation and stability of $\pm 5\%$. If tighter regulation is required for a given application, an optical feedback technique can be used. See AN-8 for further information on optical feedback.

The circuit shown in Figure 4 is the schematic diagram of the PWR-EVAL5 evaluation board. This completely

assembled and tested board can be ordered directly from Power Integrations, Inc. for evaluation of the PWR-SMP210. Complete supply specifications are included, as well as instructions on how to modify the board for other output voltages and oscillator frequencies.

The line and load regulation graphs shown below were measured on a PWR-EVAL5 board operated from a DC source. The switching frequency of the power supply was measured at 250 kHz.

The maximum output power curve shows the power output capability for the standard transformer T1002, and the performance with twice and half the normal number of primary turns. See

DA-3 for further information on ordering transformers for use with the PWR-SMP210.

The output power versus frequency curve was generated by characterization of the PWR-SMP210 at various frequencies. Several different power transformers, optimized for each frequency, were used to generate the maximum power at each point. The curves illustrate the trade-off between AC and DC power losses within the device. As AC losses rise with frequency, DC losses and output power must be reduced to maintain the same device maximum power dissipation.

Typical Performance Characteristics (Figure 4 Power Supply)

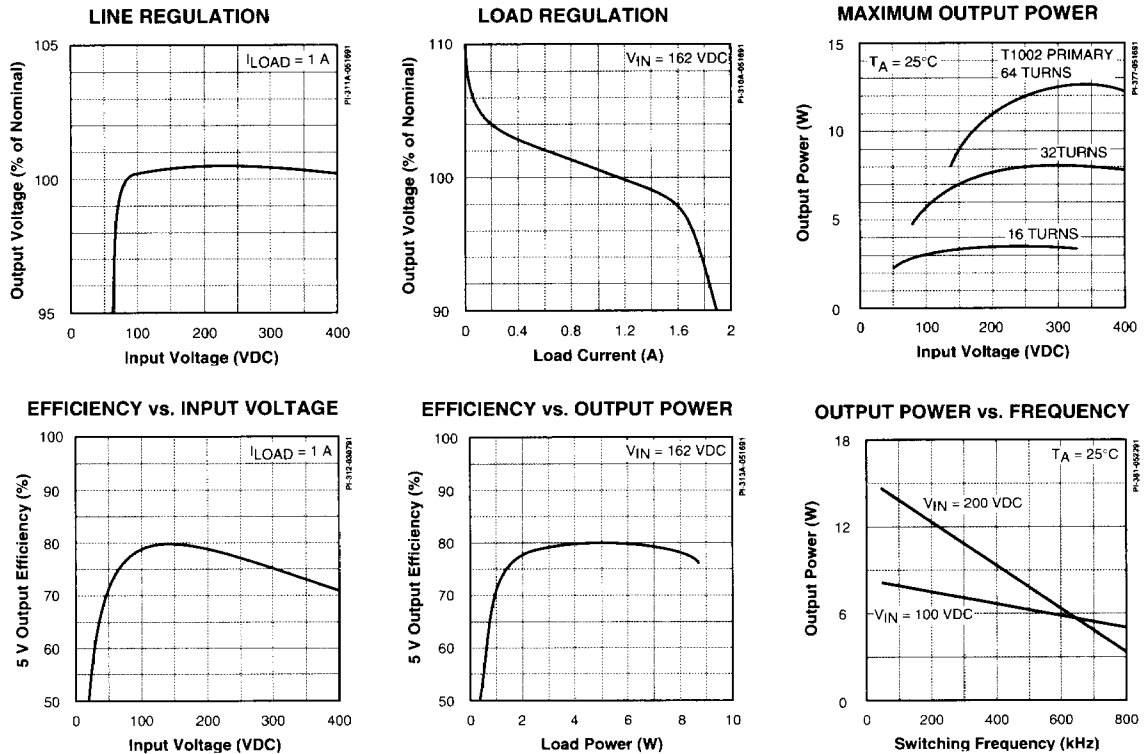

1



ABSOLUTE MAXIMUM RATINGS¹

Drain Voltage	800 V	Power Dissipation	
V _{IN} Voltage	500 V	SR Suffix (T _A = 25°C)	3.0 W
V _{BIAS} Voltage	11 V	(T _A = 70°C)	1.5 W
Drain Current	800 mA	Thermal Impedance (θ _{JA}) (BN Suffix)	43°C/W
Input Voltage ⁽²⁾	- 0.3 V to V _S + 0.3 V	(SR Suffix)	30°C/W
Storage Temperature	-65 to 125°C	Thermal Impedance (θ _{JC}) ⁽⁵⁾ (BN Suffix)	6°C/W
Ambient Temperature (C Suffix)	0 to 70°C	(SR Suffix)	6°C/W
(I Suffix)	-40 to 85°C		
Junction Temperature ⁽³⁾	150°C		
Lead Temperature ⁽⁴⁾	260°C		
Power Dissipation			
BN Suffix (T _A = 25°C)	2.1 W		
(T _A = 70°C)	1.05 W		

1. Unless noted, all voltages referenced to COM.
2. Does not apply to V_{IN} or DRAIN.
3. Normally limited by internal circuitry.
4. 1/16" from case for 5 seconds.
5. Measured at pin 12/13.

Specification	Symbol	Test Conditions, Unless Otherwise Specified: V _{IN} = 325 V, V _{BIAS} = 8.5 V, COM = 0 V R _{EXT} = 20.5 kΩ (T _A = Full Operating Range (see Note 1))	Test Limits			Units
			MIN	TYP	MAX	
OSCILLATOR						
Output Frequency	f _{OSC}	C _{EXT} = Open	650	750	850	kHz
PULSE WIDTH MODULATOR						
Duty Cycle Range	DC	C _{EXT} = Open	0-35	0-40		%
		f _{OSC} = 200 kHz	0-48	0-50		
CIRCUIT PROTECTION						
Current Limit Voltage Range		See Note 2	0		1	V
Current Limit Threshold			0.31	0.34	0.37	V
Current Limit Delay Time	t _{d(off)}	See Figure 5		250	500	ns
Thermal Shutdown Temperature			115	135		°C
Thermal Shutdown Hysteresis				45		°C



Specification	Symbol	Test Conditions, Unless Otherwise Specified: $V_{IN} = 325\text{ V}$, $V_{BIAS} = 8.5\text{ V}$, $COM = 0\text{ V}$ $R_{EXT} = 20.5\text{ k}\Omega$ ($T_A =$ Full Operating Range (see Note 1))		Test Limits			Units
				MIN	TYP	MAX	
ERROR AMPLIFIER							
Reference Voltage	V_{REF}		1.21	1.25	1.29		V
Reference Voltage Temperature Drift	ΔV_{REF}			50			ppm/°C
Gain-Bandwidth Product				500			kHz
DC Gain	A_{VOL}		60	80			dB
Output Impedance	Z_{OUT}			1.5			k Ω
OUTPUT							
ON-State Resistance	$R_{DS(ON)}$	$I_D = 100\text{ mA}$	$T_J = 25^\circ\text{C}$		20	35	Ω
			$T_J = 115^\circ\text{C}$		32	42	
ON-State Current	$I_{D(ON)}$	$V_{DS} = 10\text{ V}$	200	380			mA
OFF-State Current	I_{DSS}	$V_{DRAIN} = 640\text{ V}$, $T_A = 115^\circ\text{C}$		10	50		μA
Breakdown Voltage	BV_{DSS}	$I_{DRAIN} = 100\text{ }\mu\text{A}$, $T_A = 25^\circ\text{C}$	800	900			V
Output Capacitance	C_{OSS}	$V_{DRAIN} = 25\text{ V}$, $f = 1\text{ MHz}$		70			pF
Output Stored Energy	E_{OSS}	$V_{DRAIN} = 400\text{ V}$		1000			nJ
Rise Time	t_r	See Figure 5		70	150		ns
Fall Time	t_f	See Figure 5		70	150		ns
SUPPLY							
Pre-regulator Voltage	V_{IN}		36		500		V

1



Specification	Symbol	Test Conditions, Unless Otherwise Specified: $V_{IN} = 325\text{ V}$, $V_{BIAS} = 8.5\text{ V}$, $COM = 0\text{ V}$ $R_{EXT} = 20.5\text{ k}\Omega$ ($T_A = \text{Full Operating Range (see Note 1)}$)		Test Limits			Units
				MIN	TYP	MAX	
SUPPLY (cont.)							
Pre-regulator Cutoff Voltage	$V_{BIAS(CO)}$			6.5		8.25	V
Off-line Supply Current	I_{IN}	V_{BIAS} not connected, $C_{EXT} = \text{Open}$	C Suffix		3	4.5	mA
			I Suffix		3	5.0	
		$V_{BIAS} > 8.25\text{ V}$				0.1	
V_{BIAS} Supply Voltage	V_{BIAS}	V_{BIAS} externally supplied via feedback		8.25		9.0	V
V_{BIAS} Supply Current	I_{BIAS}	V_{BIAS} externally supplied via feedback	C Suffix		3	4.5	mA
			I Suffix		3	5.0	
V_S Source Voltage	V_S			5.1		6.0	V
V_S Source Current	I_S					400	μA

NOTES:

- Those specifications having only one limit number apply over the entire temperature range for both C Suffix (0 to 70°C), and I Suffix (-40 to 85°C) versions. Those specifications with a split limit showing each temperature range separately are as marked.
- Applying $>3.5\text{ V}$ to the I_{LIMIT} pin activates an internal test circuit that turns on the output switch continuously. Destruction of the part can occur if the output of the PWR-SMP210 is connected to a high voltage power source when the test circuit is activated.



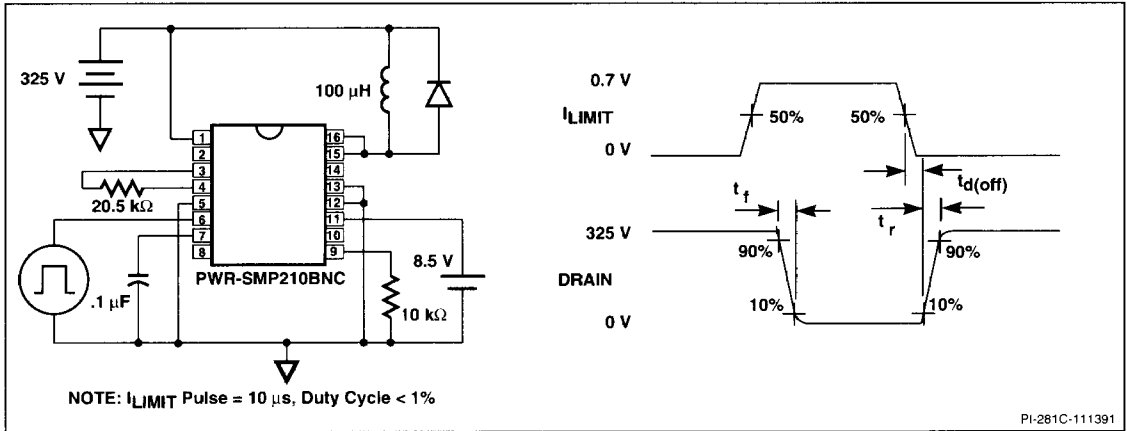
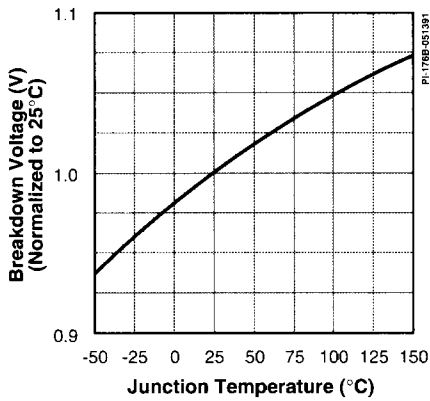
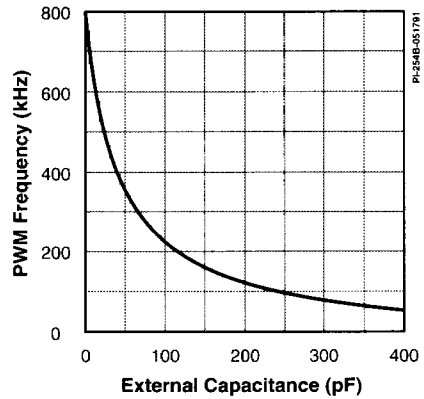

Figure 5. Switching Time Test Circuit.

BREAKDOWN vs. TEMPERATURE



f_{PWM} vs. EXTERNAL CAPACITANCE



C_{oss} vs. DRAIN VOLTAGE

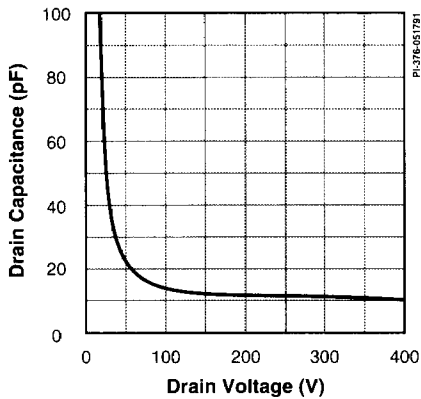

DRAIN CHARGE vs. DRAIN VOLTAGE

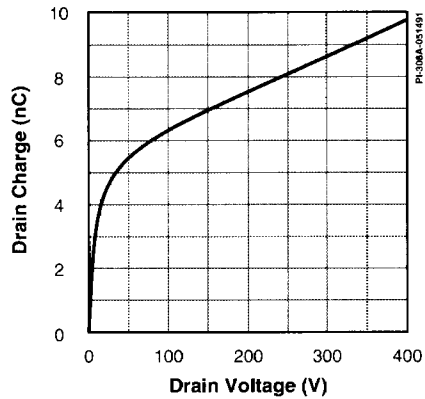

1



DRAIN CAPACITANCE ENERGY

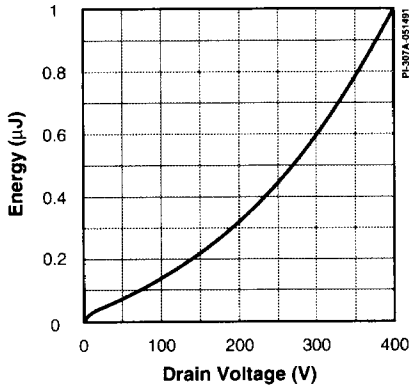

TRANSFER CHARACTERISTICS

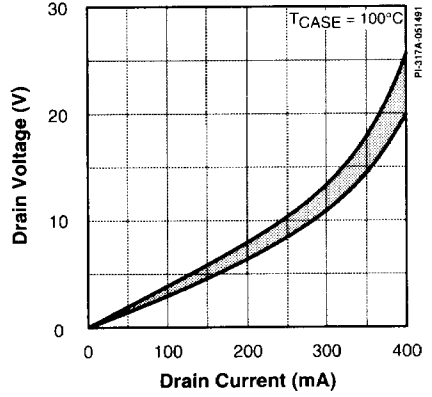

PACKAGE POWER DERATING

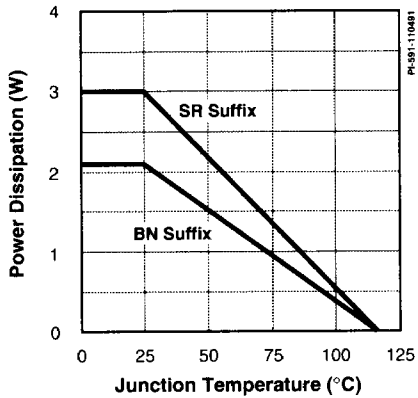

TRANSIENT THERMAL IMPEDANCE

