



PY25Q512HB-Automotive

Low Power, 512M-bit

Serial Multi I/O Flash Memory Datasheet

Performance Highlight

- ◆ *Supply Range from 2.7 to 3.6V for Read, Erase and Program*
- ◆ *Low Power consumption for Read, Erase and Program*
- ◆ *X1, X2 and X4 Multi I/O, QPI, DTR Support*
- ◆ *High reliability with 100K cycling and 20 Year-retention*



1 Overview

General

- **Single 2.7 to 3.6V supply**
- **Serial Peripheral Interface (SPI) Compatible: Mode 0 and Mode 3**
- **Single, Dual, Quad SPI, QPI, DTR**
 - Standard SPI: SCLK, CS#, SI, SO, WP#, HOLD#
 - Dual SPI: SCLK, CS#, IO0, IO1, WP#, HOLD#
 - Quad SPI: SCLK, CS#, IO0, IO1, IO2, IO3
 - QPI: SCLK, CS#, IO0, IO1, IO2, IO3
 - DTR: Double Transfer Rate Read
- **Flexible Architecture for Code and Data Storage**
 - Uniform 256-byte Page Program
 - Uniform 4K-byte Sector Erase
 - Uniform 32K/64K-byte Block Erase
 - Full Chip Erase
- **Hardware Controlled Locking of Protected Sectors by WP# Pin**
- **One Time Programmable (OTP) Security Register**
 - 3*1024-Byte Security Registers with OTP Lock
- **128-bit Unique ID for each device**
- **Fast Program and Erase Speed Typical**
 - 0.25ms Page program time
 - 30ms 4K-byte sector erase time
 - 0.10/0.15s 32K/64K-byte block erase time
 - 64s Full chip erase time
- **JEDEC Standard Manufacturer and Device ID Read Methodology**
- **Ultra-Low Power Consumption Typical**
 - 2uA Deep Power Down current
 - 50uA Standby current
 - 12mA Active Read current at 80MHz 4IO
 - 12mA Active Program or Erase current
- **High Reliability**
 - 100,000 Program / Erase Cycles
 - 20-year Data Retention
- **Industry Standard Green Package Options**
 - 8-Pad WSON (8x6x0.75mm)
 - 16-Lead SOP (300mil)
 - 24-Ball TFBGA(6x8mm)
- **It is compliant with the Automotive standard AEC-Q100 Grade 1**
- **AEC-Q100 qualified**

Note: 1. More than 10,000 Erase/Program cycles tested in compliance with AEC-Q100 (refer to Reliability Report).

2. Data retention time will reduce significantly after extensive Program/Erase cycling at high temperature.



2 Description

The PY25Q512HB-Auto is a serial interface Flash memory device designed for use in a wide variety of high-volume consumer-based applications in which program code is shadowed from Flash memory into embedded or external RAM for execution. The flexible erase architecture of the device, with its page erase granularity it is ideal for data storage as well, eliminating the need for additional data storage devices.

The erase block sizes of the device have been optimized to meet the needs of today's code and data storage applications. By optimizing the size of the erase blocks, the memory space can be used much more efficiently. Because certain code modules and data storage segments must reside by themselves in their own erase regions, the wasted and unused memory space that occurs with large sectored and large block erase Flash memory devices can be greatly reduced. This increased memory space efficiency allows additional code routines and data storage segments to be added while still maintaining the same overall device density.

The device also contains an additional 3*1024-byte security registers with OTP lock (One-Time Programmable), can be used for purposes such as unique device serialization, system-level Electronic Serial Number (ESN) storage, locked key storage, etc.

Specifically designed for use in many different systems, the device supports read, program, and erase operations with a supply voltage range of 2.7V to 3.6V. No separate voltage is required for programming and erasing.

3 Pin Definition

3.1 Pin Configurations WSON8 (8x6mm)

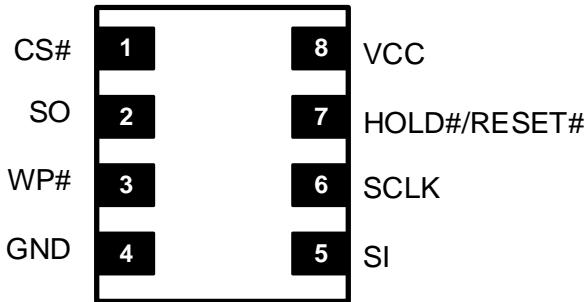

8-Pad WSON (8x6mm)

3-1 Pin Descriptions WSON8 (8x6mm)

No.	Symbol	Extension	Remarks
1	CS#		Chip select
2	SO	SIO1	Serial data output for 1 x I/O Serial data input and output for 4 x I/O read mode
3	WP#	SIO2	Write protection active low Serial data input and output for 4 x I/O read mode With weak pull up
4	GND	-	Ground of the device
5	SI	SIO0	Serial data input for 1x I/O Serial data input and output for 4 x I/O read mode
6	SCLK	-	Serial interface clock input
7	HOLD#/RESET#	SIO3	Hardware Reset Pin Active low or to pause the device without deselecting the device Serial data input and output for 4 x I/O read mode With weak pull up
8	VCC	-	Power supply of the device

Notes:

1. SIO0 and SIO1 are used for Standard and Dual SPI instructions
2. SIO0 – SIO3 are used for Quad SPI instructions, WP#& HOLD# (or RESET#) functions are only available for Standard/Dual SPI.

3.2 Pin Configurations SOP16 (300mil)

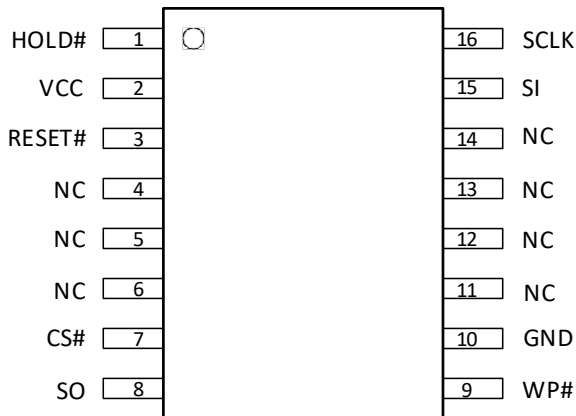

16-Pin SOP (300mil)

3-2 Pin Descriptions SOP16 (300mil)

No.	Symbol	Extension	Remarks
1	HOLD#	SIO3	To pause the device without deselecting the device Serial data input and output for 4 x I/O read mode
2	VCC	-	Power supply of the device
3	RESET#	-	Hardware Reset Pin Active low
4	NC	-	No Connect
5	NC	-	No Connect
6	NC	-	No Connect
7	CS#		Chip select
8	SO	SIO1	Serial data output for 1 x I/O Serial data input and output for 4 x I/O read mode
9	WP#	SIO2	Write protection active low Serial data input and output for 4 x I/O read mode
10	GND	-	Ground of the device
11	NC	-	No Connect
12	NC	-	No Connect
13	NC	-	No Connect
14	NC	-	No Connect
15	SI	SIO0	Serial data input for 1x I/O Serial data input and output for 4 x I/O read mode
16	SCLK	-	Serial interface clock input

Notes:

1. SIO0 and SIO1 are used for Standard and Dual SPI instructions
2. SIO0 – SIO3 are used for Quad SPI instructions, WP## HOLD# (or RESET#) functions are only available for Standard/Dual SPI.
3. The RESET# pin on SOP-16 package is a dedicated hardware reset pin regardless of device settings. ***This pin can't be floating.***

3.3 Pin Configurations 24-Ball TFBGA

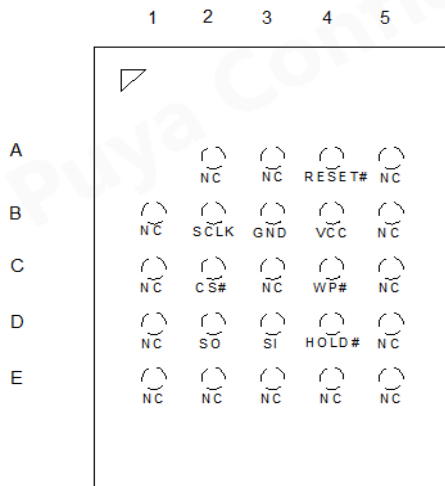

24-Ball TFBGA (6x8mm)

3-3 Pin Descriptions 24-Ball TFBGA

NO	Symbol	Extension	Remarks
A4	RESET#		Hardware Reset Pin Active Low
B2	SCLK		Serial interface clock input
B3	GND		Ground of the device
B4	VCC		Power supply of the device
C2	CS#		Chip select
C4	WP#	SIO2	Write protection active low Serial data input and output for 4 x I/O read mode
D2	SO	SIO1	Serial data output for 1 x I/O Serial data input and output for 4 x I/O read mode
D3	SI	SIO0	Serial data input for 1x I/O Serial data input and output for 4 x I/O read mode
D4	HOLD#	SIO3	To pause the device without deselecting the device Serial data input and output for 4 x I/O read mode



4 Block Diagram

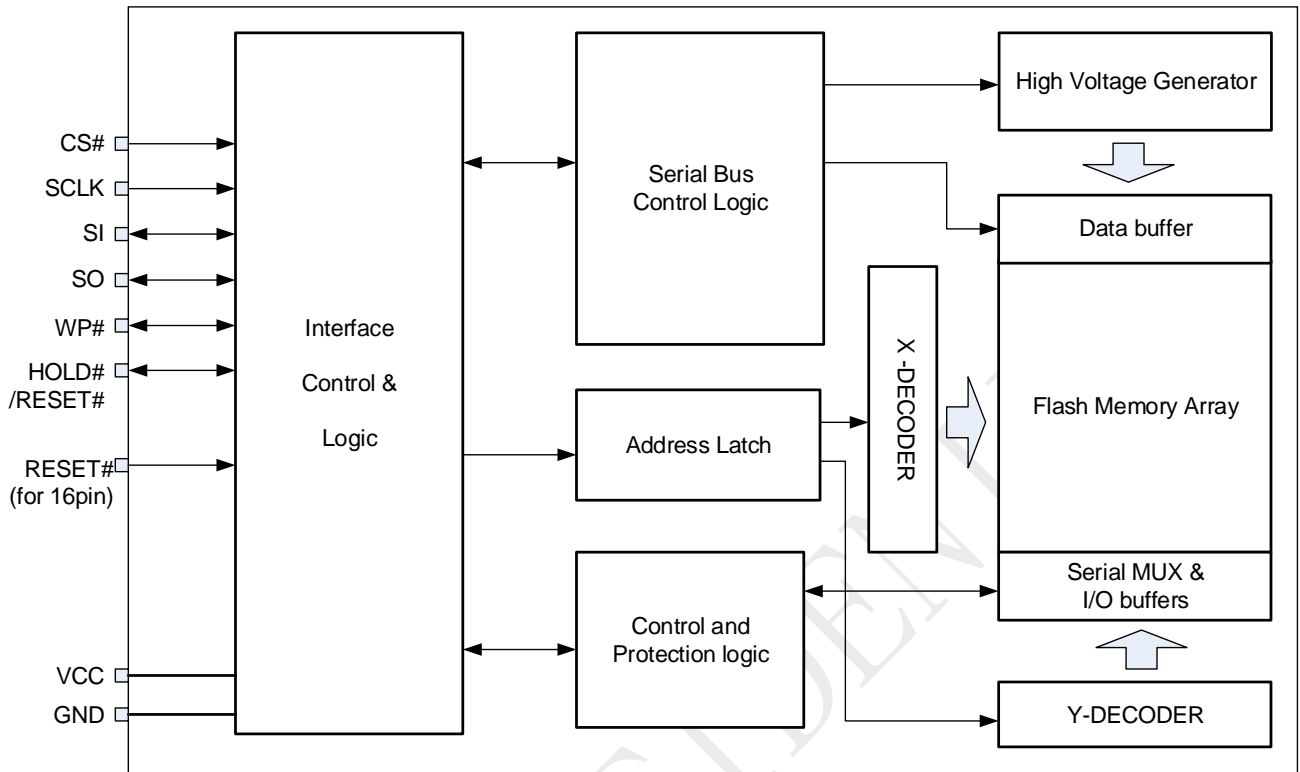



5 Electrical Specifications

5.1 Absolute Maximum Ratings

- Storage Temperature-65°C to +150°C
- Maximum Operation Voltage..... 4.1V
- Voltage on Any Pin with respect to Ground.....-0.6V to VCC+0.5V
- DC Output Current5.0 mA

NOTICE: Stresses above those listed under “Absolute Maximum Ratings” may cause permanent damage to the device. This is a stress rating only and functional operation of the device at those or any other conditions above those indicated in the operational listings of this specification is not implied. Exposure to maximum rating conditions for extended periods may affect device reliability.

Table 5-1 Pin Capacitance [1]

Symbol	Parameter	Max	Units	Test Condition
C _{OUT}	Output Capacitance	16	pF	V _{OUT} =GND
C _{IN}	Input Capacitance	12	pF	V _{IN} =GND

Note:

1. Test Conditions: T_A= 25°C, F = 1MHz, V_{CC} = 3.0V.

Figure 5-1 Input Test Waveforms and Measurement Level

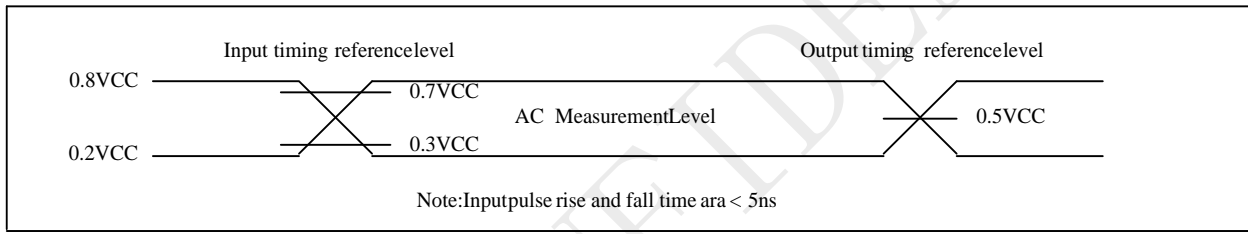



5.2 DC Characteristics

Table 5-2-1 Operation Conditions

Symbol	Parameter	Min	Max	Units
VCC	Supply voltage	2.7	3.6	V
Ta	Ambient operating temperature (Grade H)	-40	105	°C
Ta	Ambient operating temperature (Grade A)	-40	125	°C

Table 5-2-2 DC parameters ⁽¹⁾ (Device Grade H)

Symbol	Parameter	Conditions	2.7V~3.6V			Units
			Min	Typ ⁽²⁾	Max	
I _{DPD}	Deep power down current	CS#=Vcc, all other inputs at 0V or Vcc		2	30	uA
I _{SB}	Standby current	CS#, HOLD#, WP#=VIH all inputs at CMOS levels		50	120	uA
I _{CC1}	Read current (STR) (1, 2, 4 IO)	f=80MHz; IOU=0mA		12	20	mA
		f=104MHz; IOU=0mA		15	24	mA
		f=133MHz; IOU=0mA		19	31	mA
I _{CC2}	Read current (DTR) (1, 2, 4 IO)	f=50MHz; IOU=0mA		12	22	mA
		f=80MHz; IOU=0mA		18	30	mA
I _{CC3}	Program current	CS#=Vcc		12	20	mA
I _{CC4}	SE/BE32/BE64 and CE(60H) current	CS#=Vcc		12	20	mA
I _{CC5}	CE(C7H) current	CS#=Vcc		24	40	mA
I _{LI}	Input load current	All inputs at CMOS level			1.0	uA
I _{LO}	Output leakage	All inputs at CMOS level			1.0	uA
V _{IL}	Input low voltage		-0.5		0.3Vcc	V
V _{IH}	Input high voltage		0.7Vcc		Vcc+0.3	V
V _{OL}	Output low voltage	IOL=100uA			0.2	V
V _{OH}	Output high voltage	IOH=-100uA	Vcc-0.2			V

Table 5-2-3 DC parameters ⁽¹⁾ (Device Grade A)

Symbol	Parameter	Conditions	2.7V~3.6V			Units
			Min	Typ ⁽²⁾	Max	
I _{DPD}	Deep power down current	CS#=V _{cc} , all other inputs at 0V or V _{cc}		2	50	uA
I _{SB}	Standby current	CS#, HOLD#, WP#=VIH all inputs at CMOS levels		50	170	uA
I _{CC1}	Read current (STR) (1, 2, 4 IO)	f=80MHz; IO _{UT} =0mA		12	20	mA
		f=104MHz; IO _{UT} =0mA		15	24	mA
		f=133MHz; IO _{UT} =0mA		19	31	mA
I _{CC2}	Read current (DTR) (1, 2, 4 IO)	f=50MHz; IO _{UT} =0mA		12	22	mA
		f=80MHz; IO _{UT} =0mA		18	30	mA
I _{CC3}	Program current	CS#=V _{cc}		12	20	mA
I _{CC4}	SE/BE32/BE64 and CE(60H) current	CS#=V _{cc}		12	20	mA
I _{CC5}	CE(C7H) current	CS#=V _{cc}		24	40	mA
I _{LI}	Input load current	All inputs at CMOS level			1.0	uA
I _{LO}	Output leakage	All inputs at CMOS level			1.0	uA
V _{IL}	Input low voltage		-0.5		0.3V _{cc}	V
V _{IH}	Input high voltage		0.7V _{cc}		V _{cc} +0.3	V
V _{OL}	Output low voltage	I _{OL} =100uA			0.2	V
V _{OH}	Output high voltage	I _{OH} =-100uA	V _{cc} -0.2			V

Note

1. The value guaranteed by design or characterization, not 100% tested in production.
2. Typical value at 25°C, V_{CC}=3.0V.

Figure 5-2 Maximum Overshoot Waveform

Maximum Negative Overshoot Waveform

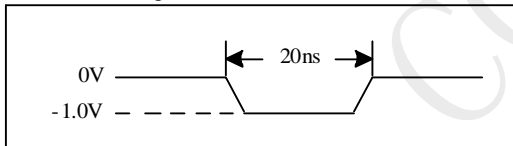

Maximum Positive Overshoot Waveform

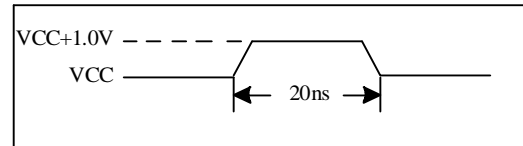

During DC conditions, input or I/O signals should remain equal to or between V_{SS} and V_{CC}. During voltage transitions, inputs or I/Os may negative overshoot to -1.0V or positive overshoot to V_{CC} + 1.0 V, for periods up to 20 ns.



5.3 AC Characteristics

Table 5-3-1 AC parameters ⁽¹⁾ (Device Grade H & A)

Symbol	Alt.	Parameter	2.7V~3.6V			Units
			Min	Typ ⁽²⁾	Max	
fSCLK	fC	Clock Frequency for all instructions except for special marking			133	MHz
fRSCLK	fR	Clock Frequency for READ instructions			80	MHz
fDSCLK	fD	Clock Frequency for DTR instructions			100	MHz
tCH(3)	tCLH	Clock High Time, 45% x (1/fSCLK)	3.3			ns
tCL(3)	tCLL	Clock Low Time, 45% x (1/fSCLK)	3.3			ns
tCLCH(7)		Clock Rise Time (peak to peak)	0.1			v/ns
tCHCL(7)		Clock Fall Time (peak to peak)	0.1			v/ns
tSLCH	tCSS	CS# Active Setup Time (relative to SCLK)	5			ns
tCHSL		CS# Not Active Hold Time (relative to SCLK)	5			ns
tDVCH	tDSU	Data In Setup Time	1.5			ns
tCHDX	tDH	Data In Hold Time	2.5			ns
tCHSH		CS# Active Hold Time (relative to SCLK)	5			ns
tSHCH		CS# Not Active Setup Time (relative to SCLK)	5			ns
tSHSL		CS# Deselect Time from Read to next Read	20			ns
		CS# Deselect Time from Write, Erase, Program to Read Status Register	30			ns
tSHQZ	tDIS	Output Disable Time			6	ns
tCLQV	tV	Clock Low to Output Valid Loading 30pF			7	ns
		Clock Low to Output Valid Loading 15pF			6	ns
tCLQX	tHO	Output Hold Time	1			ns
tCSH		CS# High Time for reset signaling protocol	500			ns
tCSL		CS# Low Time for reset signaling protocol	500			ns
tSHDX		Data hold time to CS# for reset signaling protocol	5			ns
tDVSH		Data setup time to CS# for reset signaling protocol	5			ns
tHLCH		HOLD# Active Setup Time (relative to SCLK)	5			ns
tCHHH		HOLD# Active Hold Time (relative to SCLK)	5			ns
tHHCH		HOLD# Not Active Setup Time (relative to SCLK)	5			ns
tCHHL		HOLD# Not Active Hold Time (relative to SCLK)	5			ns
tHHQX	tLZ	HOLD# to Output Low-Z			6	ns
tHLQZ	tHZ	HOLD# to Output High-Z			6	ns
tWHS(4)		Write Protect Setup Time	20			ns
tSHWL(4)		Write Protect Hold Time	100			ns
tDP		CS# High to Deep Power-down Mode			3	us
tRES1		CS# High to Standby Mode Without Electronic Signature Read			20	us
tRES2		CS# High to Standby Mode with Electronic Signature Read			20	us
tW		Write Status Register Cycle Time		2	12	ms
tReady		Reset recovery time (For operations except erase/WRSR/WRSR1/WRCR)			30	us
		Reset recovery time (for WRSR/WRSR1/WRCR operation)		2 ⁽⁵⁾	12	ms
		Reset recovery time (for erase operation)		5 ⁽⁵⁾	12	ms

Notes:

1. The value guaranteed by design or characterization, not 100% tested in production.
2. Typical value at 25°C, VCC=3.0V.
3. tCH + tCL must be greater than or equal to 1/ Frequency.
4. Only applicable as a constraint for a WRSR instruction.
5. Suggest to add checking SR WIP Bit to make sure Reset flow finished.



Table 5-3-2 SPI Read Command Performance Comparison (MHz, Device Grade H & A)

Read command	Dummy Cycles (VCC=2.7V~3.6V)			
	4	6	8	10
FREAD	-	-	133	-
DREAD	-	-	133	-
2READ	104(default)	-	133	-
QREAD	-	-	133	-
4READ	-	104(default)	-	133
DTR_FREAD	-	100	-	-
DTR_2READ	-	80(default)	100	-
DTR_4READ	-	-	80(default)	100

Table 5-3-3 QPI Read Command Performance Comparison (MHz, Device Grade H & A)

Read command	Dummy Cycles (VCC=2.7V~3.6V)			
	4	6	8	10
FREAD	80	104	120	133(default)
4READ	80	104	120	133(default)
BURST READ	80	104	120	133(default)
DTR_FREAD	-	-	80(default)	100
DTR_4READ	-	-	80(default)	100
DTR_BURST READ	-	-	80(default)	100

5.4 AC Characteristics for Program and Erase

Table 5-4 AC parameters for program and erase ⁽¹⁾ (Device Grade H & A)

Symbol	Parameter	2.7V~3.6V			Units
		Min	Typ ⁽²⁾	Max	
T _{ESL(5)}	Erase Suspend Latency			30 ⁽⁶⁾	us
T _{PSL(5)}	Program Suspend Latency			20	us
T _{PRS(3)}	Latency between Program Resume and next Suspend	1			us
T _{ERS(4)}	Latency between Erase Resume and next Suspend	1			us
t _{PP}	Byte program time		40	100	us
t _{PP}	Page program time (up to 256 bytes)		0.25	2.4	ms
t _{SE}	Sector erase time		30	240	ms
t _{BE1}	Block erase time for 32K bytes		0.10	0.8	s
t _{BE2}	Block erase time for 64K bytes		0.15	1.2	s
t _{CE}	Chip erase (C7H) time		64	160	s
	Chip erase (60H) time		128	240	s

Note

- The value guaranteed by design or characterization, not 100% tested in production.
- Typical value at 3.0V 25°C.
- Program operation may be interrupted as often as system request. The minimum timing of t_{PRS} must be observed before issuing the next program suspend command. However, in order for a Program operation to make progress, t_{PRS} ≥ 100us must be included in resume-to-suspend loop(s). Not 100% tested.
- Erase operation may be interrupted as often as system request. The minimum timing of t_{ERS} must be observed before issuing the next erase suspend command. However, in order for an Erase operation to make progress, t_{ERS} ≥ 100us must be included in resume-to-suspend loop(s). Notes. Not 100% tested.
- Latency time is required to complete Erase/Program Suspend operation.
- T_{ESL} should be waited, but cannot check by WIP.

Figure 5-4 Serial Input Timing

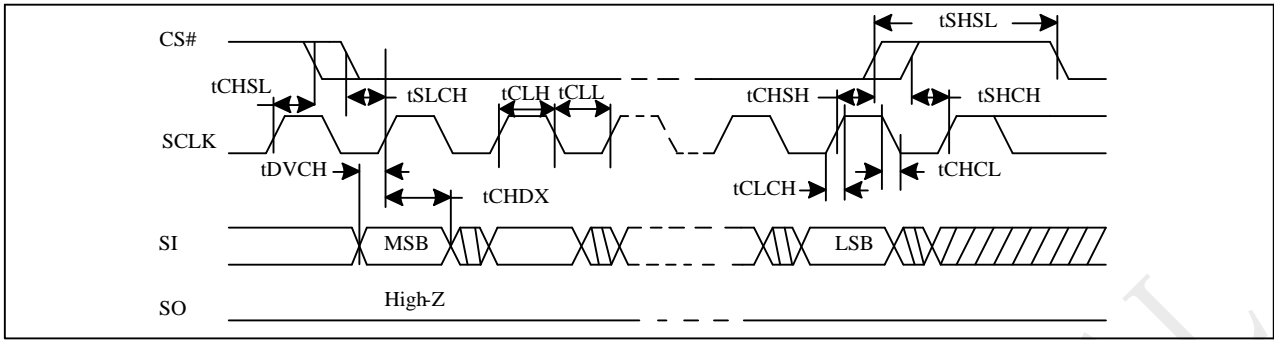

Figure 5-5 Output Timing

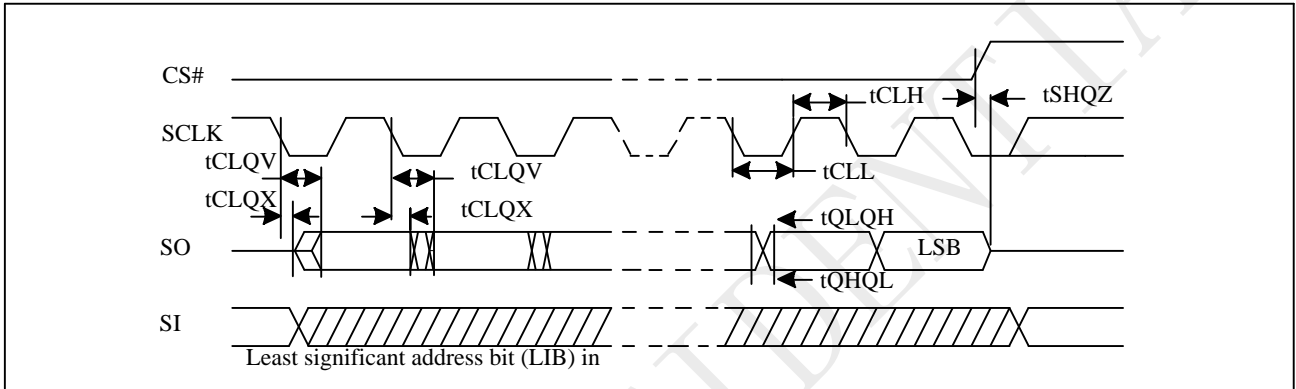

Figure 5-6 Hold Timing

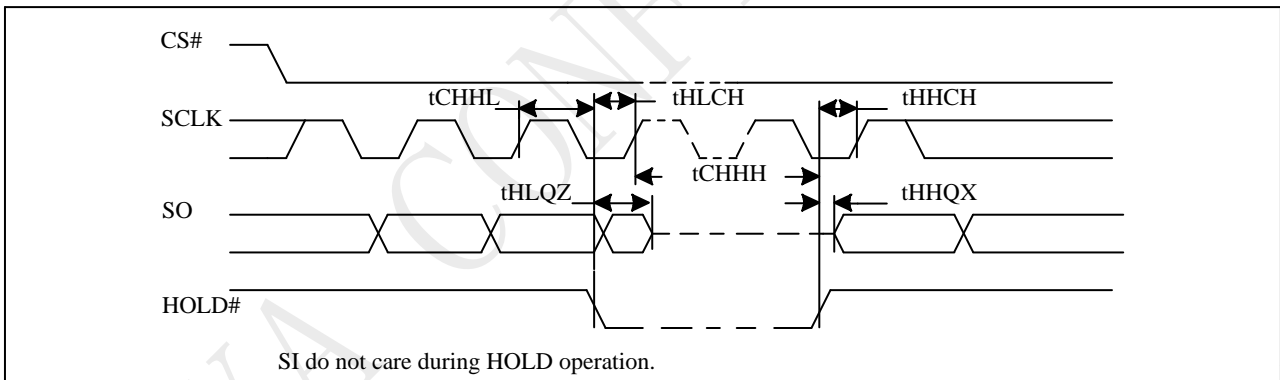
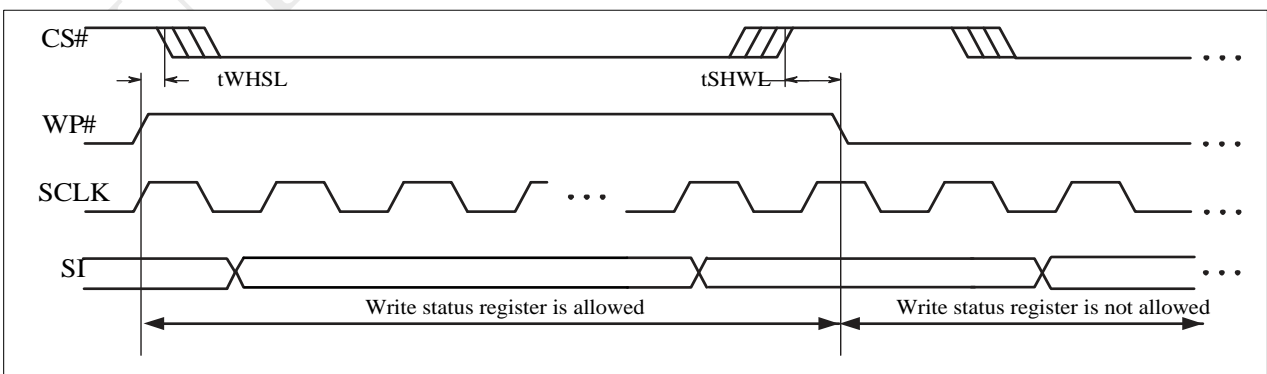

Figure 5-7 WP Timing



5.5 Operation Conditions

At Device Power-Up and Power-Down

AC timing illustrated in "Figure AC Timing at Device Power-Up" and "Figure Power-Down Sequence" are for the supply voltages and the control signals at device power-up and power-down. If the timing in the figures is ignored, the device will not operate correctly.

During power-up and power-down, CS# needs to follow the voltage applied on VCC to keep the device not to be selected. The CS# can be driven low when VCC reach $V_{cc(min)}$ and wait a period of t_{VSL} .

Figure 5-8 AC Timing at Device Power-Up

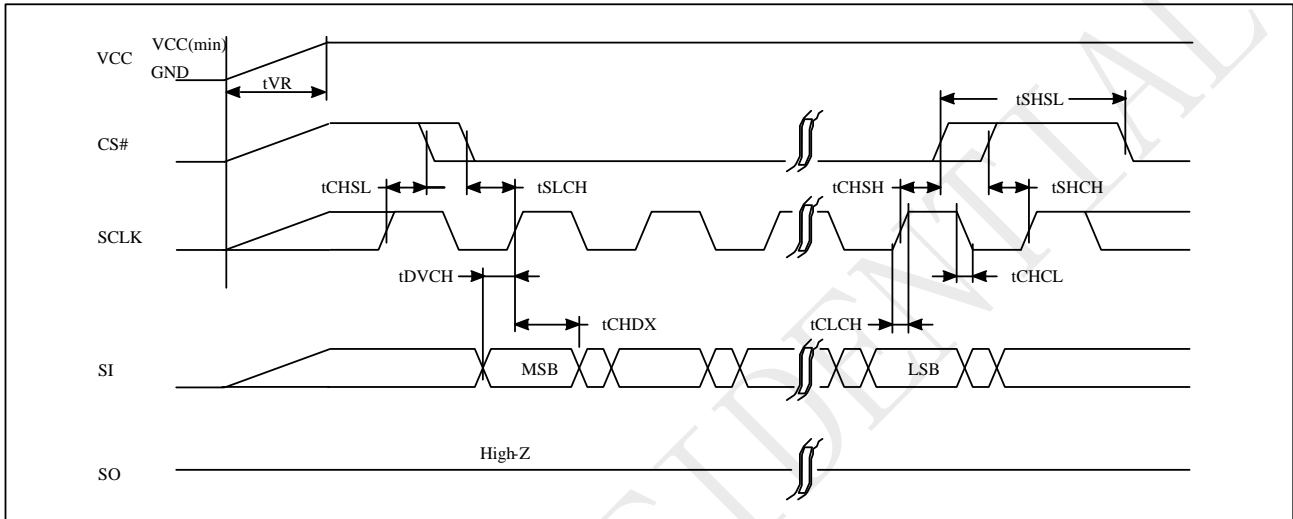
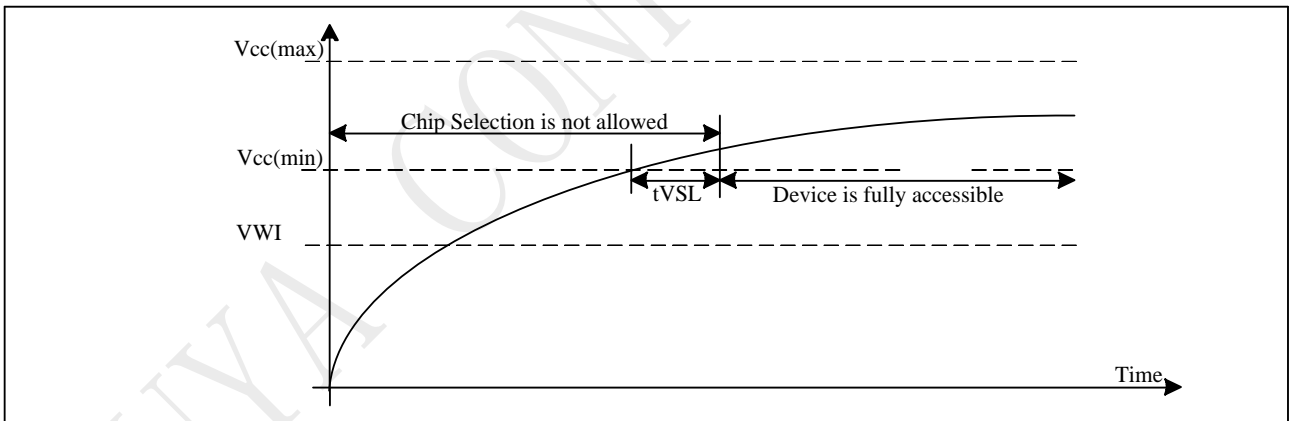

Figure 5-9 Power-up Timing



Power Up/Down and Voltage Drop

For Power-down to Power-up operation, the VCC of flash device must below VPWD for at least tPWD timing. Please check the table below for more detail.

Figure 5-10 Power down-up Timing

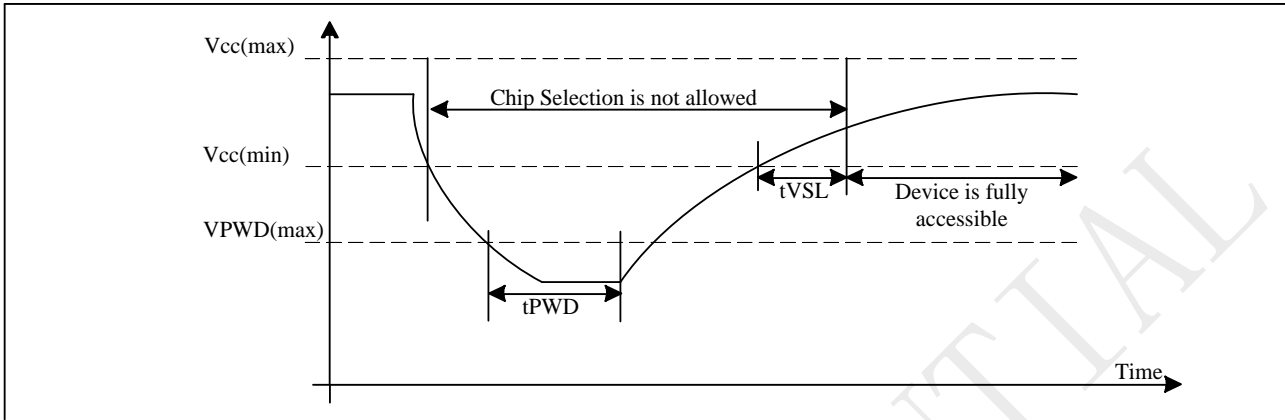

Symbol	Parameter	Min	Max	Units
VPWD	VCC voltage needed to below VPWD for ensuring initialization will occur		1.5	V
tPWD	The minimum duration for ensuring initialization will occur	300		us
tVSL	VCC(min.) to device operation	2.5		ms
tVR	VCC Rise Time	1	500,000	us/V
VWI	Write Inhibit Voltage	1.7	2.1	V

Note: if power down in erase operation, there are over erase risk. So need erase the same region again after next power up.

Initial Delivery State

The device is delivered with the memory array erased: all bits are set to 1 (each byte contains FFh). The Status Register contains 00h (all Status Register bits are 0).



6 Data Protection

During power transition, there may be some false system level signals which result in inadvertent erasure or programming. The device is designed to protect itself from these accidental write cycles.

The state machine will be reset as standby mode automatically during power up. In addition, the control register architecture of the device constrains that the memory contents can only be changed after specific command sequences have completed successfully.

In the following, there are several features to protect the system from the accidental write cycles during VCC power-up and power-down or from system noise.

- Power-on reset: to avoid sudden power switch by system power supply transition, the power-on reset may protect the Flash.
- Valid command length checking: The command length will be checked whether it is at byte base and completed on byte boundary.
- Write Enable (WREN) command: WREN command is required to set the Write Enable Latch bit (WEL) before issuing other commands to change data.
- Software Protection Mode: The Block Protect (BP4, BP3, BP2, BP1, and BP0) bits define the section of the memory array that can be read but not change.
- Hardware Protection Mode: WP# going low to protected the BP0~BP4bits and SRP0~1bits
- Deep Power-Down Mode: By entering deep power down mode, the flash device is under protected from writing all commands except the Release form Deep Power-Down Mode command.

Protected Area Sizes

Table 6-1. PY25Q512HB-Auto Protected Area Sizes (WPS=0, CMP=0)

Status Register					Memory content			
BP4	BP3	BP2	BP1	BP0	Blocks	Addresses	Density	Portion
X	0	0	0	0	NONE	NONE	NONE	NONE
0	0	0	0	1	1023	03FF0000h - 03FFFFFFh	64KB	Upper 1/1024
0	0	0	1	0	1022 thru 1023	03FE0000h - 03FFFFFFh	128KB	Upper 1/512
0	0	0	1	1	1020 thru 1023	03FC0000h - 03FFFFFFh	256KB	Upper 1/256
0	0	1	0	0	1016 thru 1023	03F80000h - 03FFFFFFh	512KB	Upper 1/128
0	0	1	0	1	1008 thru 1023	03F00000h - 03FFFFFFh	1MB	Upper 1/64
0	0	1	1	0	992 thru 1023	03E00000h - 03FFFFFFh	2MB	Upper 1/32
0	0	1	1	1	960 thru 1023	03C00000h - 03FFFFFFh	4MB	Upper 1/16
0	1	0	0	0	896 thru 1023	03800000h - 03FFFFFFh	8MB	Upper 1/8
0	1	0	0	1	768 thru 1023	03000000h - 03FFFFFFh	16MB	Upper 1/4
0	1	0	1	0	512 thru 1023	02000000h - 03FFFFFFh	32MB	Upper 1/2
1	0	0	0	1	0	00000000h - 0000FFFFh	64KB	Lower 1/1024
1	0	0	1	0	0 thru 1	00000000h - 0001FFFFh	128KB	Lower 1/512
1	0	0	1	1	0 thru 3	00000000h - 0003FFFFh	256KB	Lower 1/256
1	0	1	0	0	0 thru 7	00000000h - 0007FFFFh	512KB	Lower 1/128
1	0	1	0	1	0 thru 15	00000000h - 000FFFFh	1MB	Lower 1/64
1	0	1	1	0	0 thru 31	00000000h - 001FFFFh	2MB	Lower 1/32
1	0	1	1	1	0 thru 63	00000000h - 003FFFFh	4MB	Lower 1/16
1	1	0	0	0	0 thru 127	00000000h - 007FFFFh	8MB	Lower 1/8
1	1	0	0	1	0 thru 255	00000000h - 00FFFFFFh	16MB	Lower 1/4
1	1	0	1	0	0 thru 511	00000000h - 01FFFFFFh	32MB	Lower 1/2
X	1	0	1	1	0 thru 1024	00000000h - 03FFFFFFh	64MB	ALL
X	1	1	X	X	0 thru 1024	00000000h - 03FFFFFFh	64MB	ALL

**Table 6-2. PY25Q512HB-Auto Protected Area Sizes (WPS=0, CMP=1)**

Status Register					Memory content			
BP4	BP3	BP2	BP1	BP0	Blocks	Addresses	Density	Portion
X	0	0	0	0	ALL	00000000h - 03FFFFFFh	ALL	ALL
0	0	0	0	1	0 thru 1022	00000000h - 03FEFFFFh	65,472KB	Lower 1023/1024
0	0	0	1	0	0 thru 1021	00000000h - 03FDFFFFh	65,408KB	Lower 511/512
0	0	0	1	1	0 thru 1019	00000000h - 03FBFFFFh	65,280KB	Lower 255/256
0	0	1	0	0	0 thru 1015	00000000h - 03F7FFFFh	65,024KB	Lower 127/128
0	0	1	0	1	0 thru 1007	00000000h - 03EFFFFFh	63MB	Lower 63/64
0	0	1	1	0	0 thru 991	00000000h - 03DFFFFFh	62MB	Lower 31/32
0	0	1	1	1	0 thru 959	00000000h - 03BFFFFFh	60MB	Lower 15/16
0	1	0	0	0	0 thru 895	00000000h - 037FFFFFh	56MB	Lower 7/8
0	1	0	0	1	0 thru 767	00000000h - 02FFFFFFh	48MB	Lower 3/4
0	1	0	1	0	0 thru 511	00000000h - 01FFFFFFh	32MB	Lower 1/2
1	0	0	0	1	1 thru 1023	00010000h - 03FFFFFFh	65,472KB	Upper 1023/1024
1	0	0	1	0	2 thru 1023	00020000h - 03FFFFFFh	65,408KB	Upper 511/512
1	0	0	1	1	4 thru 1023	00040000h - 03FFFFFFh	65,280KB	Upper 255/256
1	0	1	0	0	8 thru 1023	00080000h - 03FFFFFFh	65,024KB	Upper 127/128
1	0	1	0	1	16 thru 1023	00100000h - 03FFFFFFh	63MB	Upper 63/64
1	0	1	1	0	32 thru 1023	00200000h - 03FFFFFFh	62MB	Upper 31/32
1	0	1	1	1	64 thru 1023	00400000h - 03FFFFFFh	60MB	Upper 15/16
1	1	0	0	0	128 thru 1023	00800000h - 03FFFFFFh	56MB	Upper 7/8
1	1	0	0	1	256 thru 1023	01000000h - 03FFFFFFh	48MB	Upper 3/4
1	1	0	1	0	512 thru 1023	02000000h - 03FFFFFFh	32MB	Upper 1/2
X	1	0	1	1	NONE	NONE	NONE	NONE
X	1	1	X	X	NONE	NONE	NONE	NONE

Note:

1. X=don't care
2. If any erase or program command specifies a memory that contains protected data portion, this command will be ignored.



Table 6-3. PY25Q512HB-Auto Individual Block Protection (WPS=1)

Block	Sector/Block	
Block 1023	Sector 15 (4KB)	←
	Sector 14 (4KB)	←
	-	
	-	
	Sector 1 (4KB)	←
Block 1022	Sector 0 (4KB)	←
	Block 1022 (64KB)	←
Block2 ~1021	-----	←
		←
Block 1	Block 1 (64KB)	←
Block 0	Sector 15 (4KB)	←
	Sector 14 (4KB)	←
	-	
	-	
	Sector 1 (4KB)	←
	Sector 0 (4KB)	←

**Individual Block Locks:
32 Sectors(Top/Bottom)
1022 Blocks**

Individual Block Lock:
36h+Address

Individual Block Unlock:
39h+Address

Read Block Lock:
3Ch+Address

Global Block Lock:
7Eh

Global Block Unlock:
98h

Notes:

1. Individual Block/Sector protection is only valid when WPS=1.
2. All individual block/sector lock bits are set to 1 by default after power up, all memory array is protected.
3. **Global Block Unlock instruction (98H)** must previously have been executed before Chip Erase instruction when WPS=1.



7 Memory Address Mapping

The memory array can be erased in three levels of granularity including a full chip erase. The size of the erase blocks is optimized for both code and data storage applications, allowing both code and data segments to reside in their own erase regions.

Each device has	Each block has	Each sector has	Each page has	
64M	64K/32K	4K	256	bytes
256K	256/128	16	-	pages
16K	16/8	-	-	sectors
1K/2K	-	-	-	blocks

PY25Q512HB-Auto Memory Organization

Block	Sector	Address range	
1023	16383	03FF_F000H	03FF_FFFFH

	16368	03FF_0000H	03FF_0FFFH
1022	16367	03FE_F000H	03FE_FFFFH

	16352	03FE_0000H	03FE_0FFFH
.....

.....

2	47	0002_F000H	0002_FFFFH

	32	0002_0000H	0002_0FFFH
1	31	0001_F000H	0001_FFFFH

	16	0001_0000H	0001_0FFFH
0	15	0000_F000H	0000_FFFFH

	0	0000_0000H	0000_0FFFH

8 Device Operation

Before a command is issued, status register should be checked to ensure device is ready for the intended operation.

When incorrect command is inputted to this LSI, this LSI becomes standby mode and keeps the standby mode until next CS# falling edge. In standby mode, SO pin of this LSI should be High-Z. When correct command is inputted to this LSI, this LSI becomes active mode and keeps the active mode until next CS# rising edge.

Input data is latched on the rising edge of Serial Clock (SCLK) and data shifts out on the falling edge of SCLK. The difference of serial peripheral interface mode 0 and mode 3 is shown as Figure 8-1.

For the following instructions: RDID, RDSR, RDSR1, RDSCUR, READ, FREAD, DREAD, 2READ, 4READ, QREAD, RDSFDP, RES, REMS, DREMS, QREMS, the shifted-in instruction sequence is followed by a data-out sequence. After any bit of data being shifted out, the CS# can be high. For the following instructions: WREN, WRDI, WRSR, PE, SE, BE32K, BE, CE, PP, QPP, DP, ERSCUR, PRSCUR, SUSPEND, RESUME, RSTEN, RST, the CS# must go high exactly at the byte boundary; otherwise, the instruction will be rejected and not executed.

During the progress of Write Status Register, Program, Erase operation, to access the memory array is neglected and not affect the current operation of Write Status Register, Program, Erase.

Figure 8-1 Serial Peripheral Interface Modes Supported

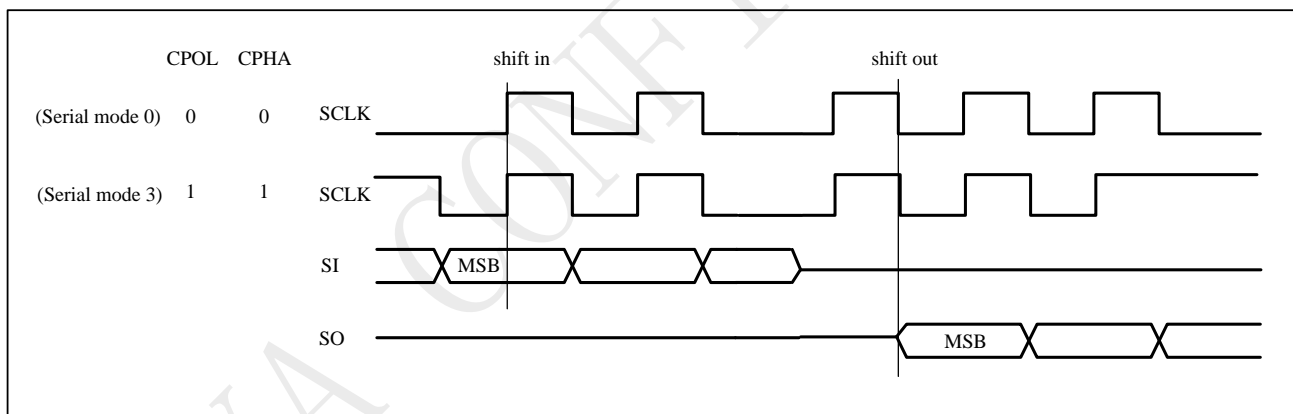

Note:

CPOL indicates clock polarity of serial master, CPOL=1 for SCLK high while idle, CPOL=0 for SCLK low while not transmitting. CPHA indicates clock phase. The combination of CPOL bit and CPHA bit decides which serial mode is supported.

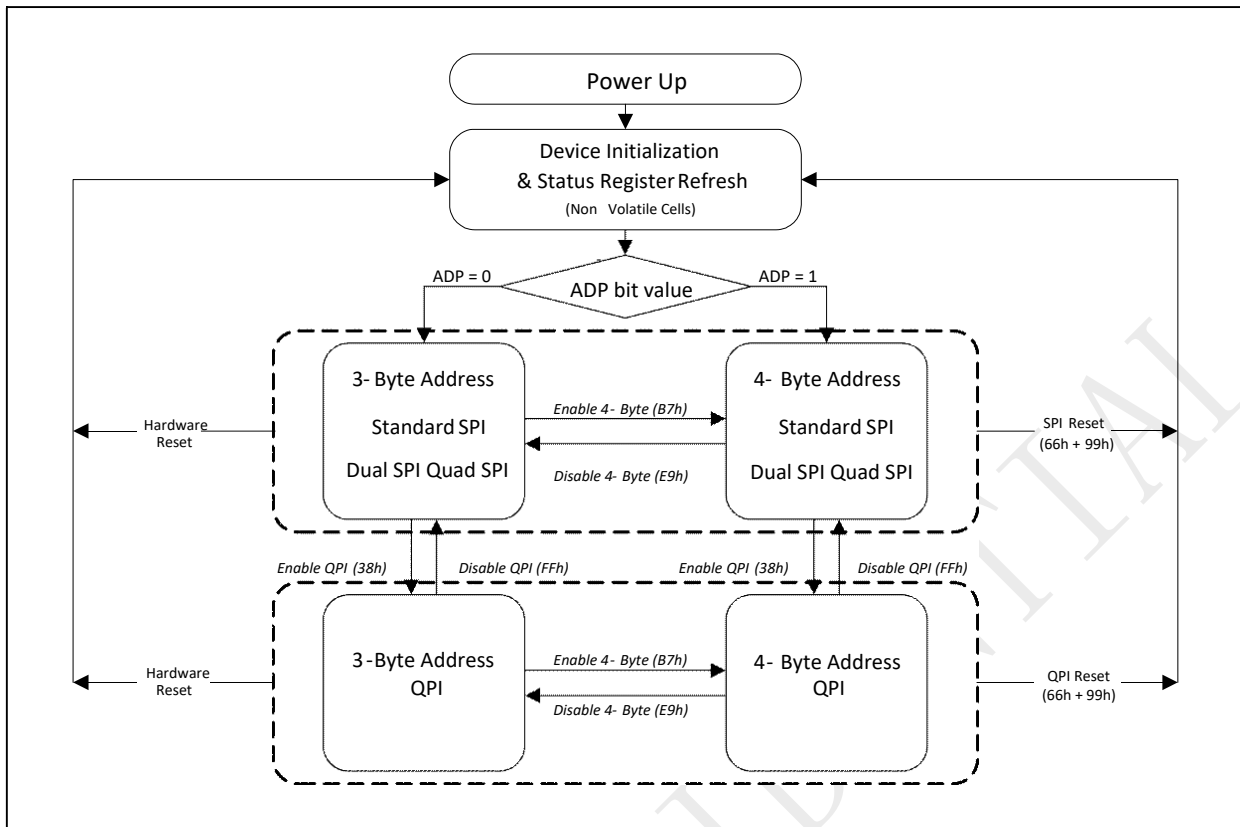

Standard SPI

The PY25Q512HB-Auto features a serial peripheral interface on 4 signals bus: Serial Clock (SCLK), Chip Select (CS#), Serial Data Input (SI) and Serial Data Output (SO). Both SPI bus mode 0 and 3 are supported. Input data is latched on the rising edge of SCLK and data shifts out on the falling edge of SCLK.

Dual SPI

The PY25Q512HB-Auto supports Dual SPI operation when using the “Dual Output Fast Read” and “Dual I/O Fast Read” (3BHand BBH) commands. These commands allow data to be transferred to or from the device at two times the rate of the standard SPI. When using the Dual SPI command the SI and SO pins become bidirectional I/O pins: IO0 and IO1.

Quad SPI

The PY25Q512HB-Auto supports Quad SPI operation when using the “Quad Output Fast Read”, “Quad I/O Fast Read” (6BH, EBH) commands. These commands allow data to be transferred to or from the device at four times the rate of the standard SPI. When using the Quad SPI command the SI and SO pins become bidirectional I/O pins: IO0 and IO1, and WP# and HOLD# pins become IO2 and IO3. Quad SPI commands require the non-volatile Quad Enable bit (QE) in Status Register to be set.

QPI

The PY25Q512HB-Auto supports Quad Peripheral Interface (QPI) operations only when the device is switched from Standard/Dual/Quad SPI mode to QPI mode using the “Enable the QPI (38H)” command. The QPI mode utilizes all four IO pins to input the command code. Standard/Dual/Quad SPI mode and QPI mode are exclusive. Only one mode can be active at any given times. “Enable the QPI (38H)” and “Disable the QPI (FFH)” commands are used to switch between these two modes. Upon power-up and after software reset using “Reset (99H)” command, the default state of the device is Standard/Dual/Quad SPI mode. The QPI mode requires the non-volatile Quad Enable bit (QE) in Status Register to be set.



SPI / QPI DTR Read Instructions

To effectively improve the read operation throughput without increasing the serial clock frequency, PY25Q512HB- Auto introduces multiple DTR (Double Transfer Rate) Read instructions that support Standard/Dual/Quad SPI and QPI modes. The byte-long instruction code is still latched into the device on the rising edge of the serial clock similar to all other SPI/QPI instructions. Once a DTR instruction code is accepted by the device, the address input and data output will be latched on both rising and falling edges of the serial clock.

3-Byte / 4-Byte Address Modes

The PY25Q512HB-Auto provides two Address Modes that can be used to specify any byte of data in the memory array. The 3-Byte Address Mode is backward compatible to older generations of serial flash memory that only support up to 128M-bit data. To address the 128M-bit or more data in 3-Byte Address Mode, Extended Address Register must be used in addition to the 3-Byte addresses.

4-Byte Address Mode is designed to support Serial Flash Memory devices from 256M-bit to 32G-bit. The extended Address Register is not necessary when the 4-Byte Address Mode is enabled.

Upon power up, the PY25Q512HB-Auto can operate in either 3-Byte Address Mode or 4-Byte Address Mode, depending on the Non-Volatile Status Register Bit ADP (S17) setting. If ADP=0, the device will operate in 3-Byte Address Mode; if ADP=1, the device will operate in 4-Byte Address Mode. The factory default value for ADP is 0.

To switch between the 3-Byte or 4-Byte Address Modes, “Enter 4-Byte Mode (B7h)” or “Exit 4-Byte Mode (E9h)” instructions must be used. The current address mode is indicated by the Status Register Bit ADS (S16).

PY25Q512HB-Auto also supports a set of basic SPI instructions which requires dedicated 4-Byte address regardless the device Address Mode setting.

Software Reset & Hardware RESET# pin

The PY25Q512HB-Auto can be reset to the initial power-on state by a software Reset sequence, either in SPI mode or QPI mode. This sequence must include two consecutive commands: Enable Reset (66h) & Reset (99h). If the command sequence is successfully accepted, the device will take approximately tReady to reset. No command will be accepted during the reset period.

The PY25Q512HB-Auto can also be configured to utilize a hardware RESET# pin. The HOLD/RST bit in the Configure Register is the configuration bit for HOLD# pin function or RESET# pin function. When HOLD/RST=0 (factory default), the pin acts as a HOLD# pin as described above; when HOLD/RST=1, the pin acts as a RESET# pin. Drive the RESET# pin low for a minimum period of ~1us (tRLRH) will reset the device to its initial power-on state. Any on-going Program/Erase operation will be interrupted and data corruption may happen. While RESET# is low, the device will not accept any command input.

If QE bit is set to 1, the HOLD or RESET function will be disabled, the pin will become one of the four data I/O pins.

Hardware RESET# pin has the highest priority among all the input signals. Drive RESET# low for a minimum period of ~1us (tRLRH) will interrupt any on-going external/internal operations, regardless the status of other SPI signals (/CS, CLK, IOs, WP# and/or HOLD#).

Note:

- 1.While a faster RESET# pulse (as short as a few hundred nanoseconds) will often reset the device, a 1us minimum is recommended to ensure reliable operation.
- 2.There is an internal pull-up resistor for the dedicated RESET# pin. If the reset function is not needed, this pin can be left floating in the system.

9 Hold Feature

HOLD# pin signal goes low to hold any serial communications with the device. The HOLD feature will not stop the operation of write status register, programming, or erasing in progress.

The operation of HOLD requires Chip Select (CS#) keeping low and starts on falling edge of HOLD# pin signal while Serial Clock (SCLK) signal is being low (if Serial Clock signal is not being low, HOLD operation will not start until Serial Clock signal being low). The HOLD condition ends on the rising edge of HOLD# pin signal while Serial Clock (SCLK) signal is being low (if Serial Clock signal is not being low, HOLD operation will not end until Serial Clock being low).

Figure 9-1 Hold Condition Operation

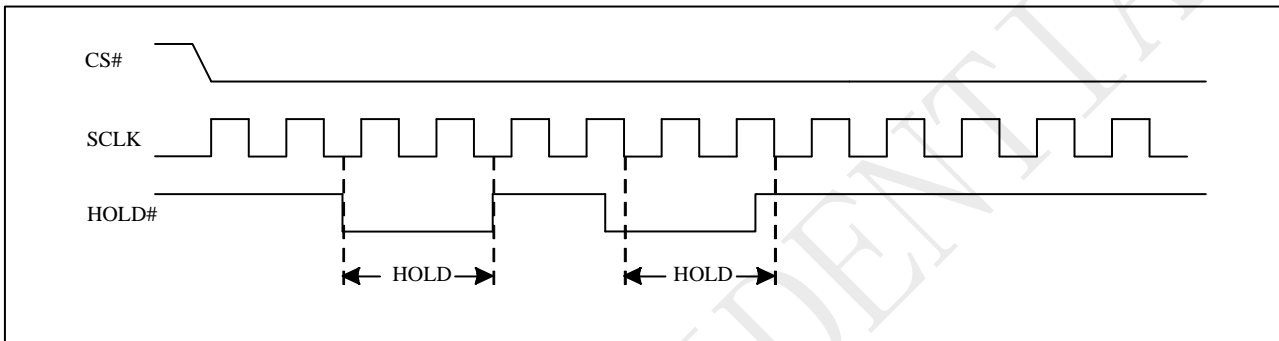

During the HOLD operation, the Serial Data Output (SO) is high impedance when HOLD# pin goes low and will keep high impedance until HOLD# pin goes high. The Serial Data Input (SI) is don't care if both Serial Clock (SCLK) and Hold# pin goes low and will keep the state until SCLK goes low and Hold# pin goes high. If Chip Select (CS#) drives high during HOLD operation, it will reset the internal logic of the device. To re-start communication with chip, the HOLD# must be at high and CS# must be at low.

Note: The HOLD feature is disabled during Quad I/O mode.



10 Commands

10.1 Commands listing

10.1.1 SPI Commands listing

Table 10-1 Command set (Standard/Dual/Quad SPI,3-Byte Address Mode)

Commands	Abbr.	Code	ADR Bytes	DMY Cycles	Data Bytes	Function description
Read						
Read Array (fast)	FREAD	0Bh	3	8	1+	n bytes read out until CS# goes high
Read Array (fast) 4byte address	FREAD4B	0Ch	4	8	1+	n bytes read out until CS# goes high
Read Array	READ	03h	3	0	1+	n bytes read out until CS# goes high
Read Array 4byte address	READ4B	13h	4	0	1+	n bytes read out until CS# goes high
Read Dual Output	DREAD	3Bh	3	8	1+	n bytes read out by Dual output
Read Dual Output 4 byte address	DREAD4B	3Ch	4	8	1+	n bytes read out by Dual output
Read 2IO	2READ	BBh	3	4(8)	1+	n bytes read out by 2IO
Read 2IO 4 byte address	2READ4B	BC	4	4(8)	1+	n bytes read out by 2IO
Read Quad Output	QREAD	6Bh	3	8	1+	n bytes read out by Quad output
Read Quad Output 4 byte address	QREAD4B	6Ch	4	8	1+	n bytes read out by Quad output
Read 4IO	4READ	EBh	3	6(10)	1+	n bytes read out by 4IO
Read 4IO 4 byte address	4READ4B	ECh	4	6(10)	1+	n bytes read out by 4IO
Program and Erase						
Sector Erase (4K)	SE	20h	3	0	0	erase selected sector
Sector Erase (4K) 4byte address	SE4B	21h	4	0	0	erase selected sector
Block Erase (32K)	BE32K	52h	3	0	0	erase selected 32K block
Block Erase (32K) 4 byte address	BE32K4B	5Ch	4	0	0	erase selected 32K block
Block Erase (64K)	BE	D8h	3	0	0	erase selected 64K block
Block Erase (64K) 4byte address	BE4B	DCh	4	0	0	erase selected 64K block
Chip Erase	CE	60h/C7h	0	0	0	erase whole chip
Page Program	PP	02h	3	0	1+	program selected page
Page Program 4byte address	PP4B	12h	4	0	1+	program selected page
Quad data-in page program	QPP	32h	3	0	1+	Quad data input to program selected page
Quad data-in page program 4byte address	QPP4B	34h	4	0	1+	Quad data input to program selected page
Quad-in page program	QIPP	C2h	3	0	1+	quad input to program selected page
Quad-in page program 4byte address	QIPP4B	3Eh	4	0	1+	quad input to program selected page
Program/Erase Suspend	PES	75h	0	0	0	suspend program/erase operation
Program/Erase Resume	PER	7Ah	0	0	0	continue program/erase operation
Protection						
Write Enable	WREN	06h	0	0	0	sets the write enable latch bit
Write Disable	WRDI	04h	0	0	0	resets the write enable latch bit
Volatile SR Write Enable	VWREN	50h	0	0	0	Write enable for volatile SR
Individual Block Lock	SBLK	36h	3	0	0	Individual block lock
Individual Block Unlock	SBULK	39h	3	0	0	Individual block unlock
Read Block Lock Status	RDBLOCK	3Dh	3	0	1	Read individual block lock register
Global Block Lock	GBLK	7Eh	0	0	0	Whole chip block protect
Global Block Unlock	GBULK	98h	0	0	0	Whole chip block unprotect
Security						
Erase Security Registers	ERSCUR	44h	3	0	0	Erase security registers
Program Security Registers	PRSCUR	42h	3	0	1+	Program security registers
Read Security Registers	RDSCUR	48h	3	8	1+	Read value of security register
Status Register						
Read Status Register1	RDSR	05h	0	0	1	read out status register1
Read Status Register2	RDSR2	35h	0	0	1	Read out status register2
Read Configure Register	RDCR	15h	0	0	1	Read out configure register
Write Status Register1	WRSR	01h	0	0	1-2	Write data to status registers1 and status registers2
Write Status Register2	WRSR2	31h	0	0	1	Write data to status registers2
Write Configure Register	WRCR	11h	0	0	1	Write data to configuration register



Commands	Abbr.	Code	ADR Bytes	DMY Cycles	Data Bytes	Function description
Read Extended Address Register	RDEAR	C8h	0	0	1	Read out extended address register
Write Extended Address Register	WREAR	C5h	0	0	1	Write data to extended address register
Other Commands						
Reset Enable	RSTEN	66h	0	0	0	Enable reset
Reset	RST	99h	0	0	0	Reset
Enable QPI	QPIEN	38h	0	0	0	Enable QPI mode
Enter 4-Byte Address	EN4B	B7h	0	0	0	Enter 4-Byte Address Mode
Exit 4-Byte Address	EX4B	E9h	0	0	0	Exit 4-Byte Address Mode
Read Manufacturer/device ID	RDID	9Fh	0	0	1 to 3	output JEDEC ID: 1-byte manufacturer ID & 2-byte device ID
Read Manufacture ID	REMS	90h	3		1+	Read manufacturer ID/device ID data
Dual Read Manufacture ID	DREMS	92h	3	4	1+	Dual output read manufacture/device ID
Quad Read Manufacture ID	QREMS	94h	3	6	1+	Quad output read manufacture/device ID
Deep Power-down	DP	B9h	0	0	0	enters deep power-down mode
Release Deep Power-down/Read Electronic ID	RDP/RES	ABh	3	0	1	Read electronic ID data
Set burst length	SBL	77h	3	0	1	Set burst length
Read SFDP	RDSFDP	5Ah	3	8	1+	Read SFDP parameter
Release read enhanced		FFh	0	0	0	Release from read enhanced
Read unique ID	RUID	4Bh	3	8	1+	Read unique ID

Table 10-2 Command set (Standard/Dual/Quad SPI,4-Byte Address Mode)

Commands	Abbr.	Code	ADR Bytes	DMY Cycles	Data Bytes	Function description
Read						
Read Array (fast)	FREAD	0Bh	4	8	1+	n bytes read out until CS# goes high
Read Array (fast) 4byte address	FREAD4B	0Ch	4	8	1+	n bytes read out until CS# goes high
Read Array	READ	03h	4	0	1+	n bytes read out until CS# goes high
Read Array 4byte address	READ4B	13h	4	0	1+	n bytes read out until CS# goes high
Read Dual Output	DREAD	3Bh	4	8	1+	n bytes read out by Dual output
Read Dual Output 4 byte address	DREAD4B	3Ch	4	8	1+	n bytes read out by Dual output
Read 2IO	2READ	BBh	4	4(8)	1+	n bytes read out by 2IO
Read 2IO 4 byte address	2READ4B	8Ch	4	4(8)	1+	n bytes read out by 2IO
Read Quad Output	QREAD	6Bh	4	8	1+	n bytes read out by Quad output
Read Quad Output 4 byte address	QREAD4B	6Ch	4	8	1+	n bytes read out by Quad output
Read 4IO	4READ	EBh	4	6(10)	1+	n bytes read out by 4IO
Read 4IO 4 byte address	4READ4B	ECh	4	6(10)	1+	n bytes read out by 4IO
Program and Erase						
Sector Erase (4K)	SE	20h	4	0	0	erase selected sector
Sector Erase (4K) 4byte address	SE4B	21h	4	0	0	erase selected sector
Block Erase (32K)	BE32K	52h	4	0	0	erase selected 32K block
Block Erase (32K) 4 byte address	BE32K4B	5Ch	4	0	0	erase selected 32K block
Block Erase (64K)	BE	D8h	4	0	0	erase selected 64K block
Block Erase (64K) 4byte address	BE4B	DCh	4	0	0	erase selected 64K block
Chip Erase	CE	60h/C7h	0	0	0	erase whole chip
Page Program	PP	02h	4	0	1+	program selected page
Page Program 4byte address	PP4B	12h	4	0	1+	program selected page
Quad data-in page program	QPP	32h	4	0	1+	quad input to program selected page
Quad data-in page program 4byte address	QPP4B	34h	4	0	1+	quad input to program selected page
Quad-in page program	QIPP	C2h	4	0	1+	quad input to program selected page
Quad-in page program 4byte address	QIPP4B	3Eh	4	0	1+	quad input to program selected page
Program/Erase Suspend	PES	75h	0	0	0	suspend program/erase operation
Program/Erase Resume	PER	7Ah	0	0	0	continue program/erase operation
Protection						
Write Enable	WREN	06h	0	0	0	sets the write enable latch bit
Write Disable	WRDI	04h	0	0	0	resets the write enable latch bit
Volatile SR Write Enable	VWREN	50h	0	0	0	Write enable for volatile SR
Individual Block Lock	SBLK	36h	4	0	0	Individual block lock
Individual Block Unlock	SBULK	39h	4	0	0	Individual block unlock
Read Block Lock Status	RDBLOCK	3Dh	4	0	1	Read individual block lock register
Global Block Lock	GBLK	7Eh	0	0	0	Whole chip block protect
Global Block Unlock	GBULK	98h	0	0	0	Whole chip block unprotect
Security						



Commands	Abbr.	Code	ADR Bytes	DMY Cycles	Data Bytes	Function description
Erase Security Registers	ERSCUR	44h	4	0	0	Erase security registers
Program Security Registers	PRSCUR	42h	4	0	1+	Program security registers
Read Security Registers	RDSCUR	48h	4	8	1+	Read value of security register
Status Register						
Read Status Register1	RDSR	05h	0	0	1	read out status register1
Read Status Register2	RDSR2	35h	0	0	1	Read out status register2
Read Configure Register	RDCR	15h	0	0	1	Read out configure register
Write Status Register1	WRSR	01h	0	0	1 ^{Note}	Write data to status registers1 and status registers2
Write Status Register2	WRSR2	31h	0	0	1	Write data to status registers2
Write Configure Register	WRRCR	11h	0	0	1	Write data to configuration register
Read Extended Address Register	RDEAR	C8h	0	0	1	Read out extended address register
Write Extended Address Register	WREAR	C5h	0	0	1	Write data to extended address register
Other Commands						
Reset Enable	RSTEN	66h	0	0	0	Enable reset
Reset	RST	99h	0	0	0	Reset
Enable QPI	QPIEN	38h	0	0	0	Enable QPI mode
Enter 4-Byte Address	EN4B	B7h	0	0	0	Enter 4-Byte Address Mode
Exit 4-Byte Address	EX4B	E9h	0	0	0	Exit 4-Byte Address Mode
Read Manufacturer/device ID	RDID	9Fh	0	0	1 to 3	output JEDEC ID: 1-byte manufacturer ID & 2-byte device ID
Read Manufacture ID	REMS	90h	3		1+	Read manufacturer ID/device ID data
Dual Read Manufacture ID	DREMS	92h	4	4	1+	Dual output read manufacture/device ID
Quad Read Manufacture ID	QREMS	94h	4	6	1+	Quad output read manufacture/device ID
Deep Power-down	DP	B9h	0	0	0	enters deep power-down mode
Release Deep Power-down/Read Electronic ID	RDP/RES	ABh	3	0	1	Read electronic ID data
Set burst length	SBL	77h	4	0	1	Set burst length
Read SFDP	RDSFDP	5Ah	3	8	1+	Read SFDP parameter
Release read enhanced		FFh	0	0	0	Release from read enhanced
Read unique ID	RUID	4Bh	4	8	1+	Read unique ID

Note: in 4Byte mode, 01H command only support to write status registers 1

10.1.2 QPI Commands listing

Table 10-3 Command set (QPI Instructions, 3-Byte Address Mode)

Commands	Abbr.	Code	ADR Bytes	DMY Bytes	Data Bytes	Function description
Read						
Fast read	FREAD	0Bh	3	10/4/6/8	1+	n bytes read out by 4IO
Read Word 4x I/O	4READ	EBh	3	10/4/6/8	1+	n bytes read out by 4IO
Read Word 4x I/O 4byte address	4READ4B	ECh	4	10/4/6/8	1+	n bytes read out by 4IO
Burst Read with Wrap		0Ch	3	10/4/6/8	1+	n bytes burst read with wrap by 4IO
Program and Erase						
Page Program	PP	02h	3	0	1+	program selected page
Page Program 4byte address	PP4B	12h	4	0	1+	program selected page
Sector Erase (4K bytes)	SE	20h	3	0	0	erase selected sector
Sector Erase 4byte address (4K bytes)	SE4B	21h	4	0	0	erase selected sector
Block Erase (32K bytes)	BE32K	52h	3	0	0	erase selected 32K block
Block Erase 4byte address (32K bytes)	BE32K4B	5Ch	4	0	0	erase selected 32K block
Block Erase (64K bytes)	BE	D8h	3	0	0	erase selected 64K block
Block Erase 4byte address (64K bytes)	BE4B	DCh	4	0	0	erase selected 64K block
Chip Erase	CE	60h/C7h	0	0	0	erase whole chip
Program/Erase Suspend	PES	75h	0	0	0	suspend program/erase operation
Program/Erase Resume	PER	7Ah	0	0	0	continue program/erase operation
Protection						
Write Enable	WREN	06h	0	0	0	sets the write enable latch bit
Volatile SR Write Enable	WRDI	50h	0	0	0	Write enable for volatile status register
Write Disable	VWREN	04h	0	0	0	resets the write enable latch bit
Individual Block Lock	SBLK	36h	3	0	0	Individual block lock
Individual Block Unlock	SBULK	39h	3	0	0	Individual block unlock
Read Block Lock Status	RDBLOCK	3Dh	3	0	1	Read individual block lock register



Commands	Abbr.	Code	ADR Bytes	DMY Bytes	Data Bytes	Function description
Global Block Lock	GBLK	7Eh	0	0	0	Whole chip block protect
Global Block Unlock	GBULK	98h	0	0	0	Whole chip block unprotect
Status Register						
Read Status Register1	RDSR	05h	0	0	1	read out status register1
Read Status Register2	RDSR2	35h	0	0	1	Read out status register2
Read Configure Register	RDCR	15h	0	0	1	Read out configure register
Write Status Register1	WRSR	01h	0	0	1-2	Write data to status registers1 and status registers2
Write Status Register2	WRSR2	31h	0	0	1	Write data to status registers2
Write Configure Register	WRCR	11h	0	0	1	Write data to configuration register
Read Extended Address Register	RDEAR	C8h			1	Read out extended address register
Write Extended Address Register	WREAR	C5h			1	Write data to extended address register
Other Commands						
Deep Power-down	DP	B9h	0	0	0	enters deep power-down mode
Release Deep Power-down/Read Electronic ID	RDP/RES	ABh	3	0	1	Read electronic ID data
Set Read Parameters		C0h	0	0	1	Set read dummy and wrap
Read Manufacture ID	REMS	90h	3	0	1+	Read manufacturer ID/device ID data
Read Manufacturer/device ID	RDID	9Fh	0	0	1 to 3	output JEDEC ID: 1-byte manufacturer ID & 2-byte device ID
Read SFDP	RDSFDP	5Ah	3	10/4/6/8	1+	Read SFDP parameter
Read unique ID	RDUID	4Bh	3	10/4/6/8	1+	Read SFDP parameter
Enter 4-Byte Address	EN4B	B7h	0	0	0	Enter 4-Byte Address Mode
Exit 4-Byte Address	EX4B	E9h	0	0	0	Exit 4-Byte Address Mode
Disable QPI	DISQPI	FFh	0	0	0	Release from read enhanced
Reset Enable	RSTEN	66h	0	0	0	Enable reset
Reset	RST	99h	0	0	0	Reset

Table 10-4 Command set (QPI Instructions, 4-Byte Address Mode)

Commands	Abbr.	Code	ADR Bytes	DMY Bytes	Data Bytes	Function description
Read						
Fast read	FREAD	0Bh	4	10/4/6/8	1+	n bytes read out until CS# goes high
Read Word 4x I/O	4READ	EBh	4	10/4/6/8	1+	n bytes read out by 4IO
Read Word 4x I/O 4byte address	4READ4B	ECh	4	10/4/6/8	1+	n bytes read out by 4IO
Burst Read with Wrap		0Ch	4	10/4/6/8	1+	n bytes burst read with wrap by 4IO
Program and Erase						
Page Program	PP	02h	4	0	1+	program selected page
Page Program 4byte address	PP4B	12h	4	0	1+	program selected page
Sector Erase (4K bytes)	SE	20h	4	0	0	erase selected sector
Sector Erase 4byte address (4K bytes)	SE4B	21h	4	0	0	erase selected sector
Block Erase (32K bytes)	BE32K	52h	4	0	0	erase selected 32K block
Block Erase 4byte address (32K bytes)	BE32K4B	5Ch	4	0	0	erase selected 32K block
Block Erase (64K bytes)	BE	D8h	4	0	0	erase selected 64K block
Block Erase 4byte address (64K bytes)	BE4B	DCh	4	0	0	erase selected 64K block
Chip Erase	CE	60h/C7h	0	0	0	erase whole chip
Program/Erase Suspend	PES	75h	0	0	0	suspend program/erase operation
Program/Erase Resume	PER	7Ah	0	0	0	continue program/erase operation
Protection						
Write Enable	WREN	06h	0	0	0	sets the write enable latch bit
Volatile SR Write Enable	WRDI	50h	0	0	0	Write enable for volatile status register
Write Disable	VWREN	04h	0	0	0	resets the write enable latch bit
Individual Block Lock	SBLK	36h	4	0	0	Individual block lock
Individual Block Unlock	SBULK	39h	4	0	0	Individual block unlock
Read Block Lock Status	RDBLOCK	3Dh	4	0	1	Read individual block lock register
Global Block Lock	GBLK	7Eh	0	0	0	Whole chip block protect
Global Block Unlock	GBULK	98h	0	0	0	Whole chip block unprotect
Status Register						
Read Status Register1	RDSR	05h	0	0	1	read out status register1
Read Status Register2	RDSR2	35h	0	0	1	Read out status register2
Read Configure Register	RDCR	15h	0	0	1	Read out configure register
Write Status Register1	WRSR	01h	0	0	1 ^{note}	Write data to status registers1 and status



Commands	Abbr.	Code	ADR Bytes	DMY Bytes	Data Bytes	Function description
						registers2
Write Status Register2	WRSR2	31h	0	0	1	Write data to status registers2
Write Configure Register	WRCR	11h	0	0	1	Write data to configuration register
Read Extended Address Register	RDEAR	C8h	0	0	1	Read out extended address register
Write Extended Address Register	WREAR	C5h	0	0	1	Write data to extended address register
Other Commands						
Deep Power-down	DP	B9h	0	0	0	enters deep power-down mode
Release Deep Power-down/Read Electronic ID	RDP/RES	ABh	3	0	1	Read electronic ID data
Set Read Parameters		C0h	0	0	1	Set read dummy and wrap
Read Manufacture ID	REMS	90h	3		1+	Read manufacturer ID/device ID data
Read Manufacturer/device ID	RDID	9Fh	0	0	1 to 3	output JEDEC ID: 1-byte manufacturer ID & 2-byte device ID
Read SFDP	RDSFDP	5Ah	3	10/4/6/8	1+	Read SFDP parameter
Read unique ID	RDUID	4Bh	3	10/4/6/8	1+	Read SFDP parameter
Enter 4-Byte Address	EN4B	B7h	0	0	0	Enter 4-Byte Address Mode
Exit 4-Byte Address	EX4B	E9h	0	0	0	Exit 4-Byte Address Mode
Disable QPI		FFh	0	0	0	Release from read enhanced
Reset Enable	RSTEN	66h	0	0	0	Enable reset
Reset	RST	99h	0	0	0	Reset

Note: in 4Byte mode, 01H command only support to write status registers1.

10.1.3 DTR Commands listing Table 10-5 Command set (DTR Instructions, 3-Byte Address Mode)

Commands	Abbr.	Code	ADR Bytes	DMY Cycles	Data Bytes	Function description
DTR Fast Read	DTRFRD	0Dh	3	6	1+	DTR n byte fast read out
DTR 2IO Read	2DTRD	BDh	3	6/8	1+	DTR n byte read out by 2IO
DTR 4IO Read	4DTRD	EDh	3	8/10	1+	DTR n byte read out by 4IO
DTR 4IO Read with 4-Byte Address	4DTRD4B	EEH	4	8/10	1+	DTR n byte read out by 4IO

Note: in SPI DTR mode, DC bit can be used to set dummy cycles in 2DTRD/4DTRD.

Table 10-6 Command set (DTR Instructions, 4-Byte Address Mode)

Commands	Abbr.	Code	ADR Bytes	DMY Cycles	Data Bytes	Function description
DTR Fast Read	DTRFRD	0Dh	4	6	1+	DTR n byte fast read out
DTR 2IO Read	2DTRD	BDh	4	6/8	1+	DTR n byte read out by 2IO
DTR 4IO Read	4DTRD	EDh	4	8/10	1+	DTR n byte read out by 4IO
DTR 4IO Read with 4-Byte Address	4DTRD4B	EEH	4	8/10	1+	DTR n byte read out by 4IO

Table 10-7 Command set (DTR QPI Instructions, 3-Byte Address Mode)

Commands	Abbr.	Code	ADR Bytes	DMY Cycles	Data Bytes	Function description
DTR Fast Read	DTRFRD	0Dh	3	8/10	1+	DTR n byte fast read out by 4IO
DTR 4IO Read	4DTRD	EDh	3	8/10	1+	DTR n byte fast read out by 4IO
DTR Burst Read with Wrap		0Eh	3	8/10	1+	DTR n bytes burst read with wrap by 4IO
DTR 4IO Read with 4-Byte Address	4DTRD4B	EEH	4	8/10	1+	DTR n byte read out by 4IO

Note: in QPI DTR mode, DC bit can be used to set dummy cycles to 10 cycles for all QPI DTR read command.

Table 10-8 Command set (DTR QPI Instructions, 4-Byte Address Mode)

Commands	Abbr.	Code	ADR Bytes	DMY Cycles	Data Bytes	Function description
DTR Fast Read	DTRFRD	0Dh	4	8/10	1+	DTR n byte fast read out
DTR 4IO Read	4DTRD	EDh	4	8/10	1+	DTR n byte fast read out
DTR Burst Read with Wrap		0Eh	4	8/10	1+	DTR n bytes burst read with wrap by 4IO
DTR 4IO Read with 4-Byte Address	4DTRD4B	EEH	4	8/10	1+	DTR n byte read out by 4IO

NOTE:

1. Dual Output data

IO0 = (D6, D4, D2, D0)

IO1 = (D7, D5, D3, D1)



2. Dual Input Address

IO0 = (A30, A28, A26, A24,) A22, A20, A18, A16, A14, A12, A10, A8, A6, A4, A2, A0, M6, M4, M2, M0

IO1 = (A31, A29, A27, A25,) A23, A21, A19, A17, A15, A13, A11, A9, A7, A5, A3, A1, M7, M5, M3, M1

3. Quad Output Data

IO0 = (D4, D0, ...)

IO1 = (D5, D1, ...)

IO2 = (D6, D2, ...)

IO3 = (D7, D3, ...)

4. Quad Input Address

IO0 = (A28, A24,) A20, A16, A12, A8, A4, A0, M4, M0

IO1 = (A29, A25,) A21, A17, A13, A9, A5, A1, M5, M1

IO2 = (A30, A26,) A22, A18, A14, A10, A6, A2, M6, M2

IO3 = (A31, A27,) A23, A19, A15, A11, A7, A3, M7, M3

5. Fast Read Quad I/O Data

IO0 = (x, x, x, x, D4, D0, ...)

IO1 = (x, x, x, x, D5, D1, ...)

IO2 = (x, x, x, x, D6, D2, ...)

IO3 = (x, x, x, x, D7, D3, ...)

6. QPI Command, Address, Data input/output format:

CLK #0 1 2 3 4 5 6 7 8 9 10 11

IO0= C4, C0, (A28, A24,) A20, A16, A12, A8, A4, A0, D4, D0, D4, D0,

IO1= C5, C1, (A29, A25,) A21, A17, A13, A9, A5, A1, D5, D1, D5, D1

IO2= C6, C2, (A30, A26,) A22, A18, A14, A10, A6, A2, D6, D2, D6, D2

IO3= C7, C3, (A31, A27,) A23, A19, A15, A11, A7, A3, D7, D3, D7, D3

7. Security Registers Address:

Security Register1: (A31-A24=00H), A23-A16=00H, A15-A10=000100, A9-A0= Byte Address;

Security Register2: (A31-A24=00H), A23-A16=00H, A15-A10=001000, A9-A0= Byte Address;

Security Register3: (A31-A24=00H), A23-A16=00H, A15-A10=001100, A9-A0= Byte Address;

10.2 Write Enable (WREN 06H)

The Write Enable (WREN) instruction is for setting Write Enable Latch (WEL) bit. For those instructions like PP/PP4B, QPP/QPP4B, QIPP/QIPP4B, SE/SE4B, BE32K/BE32K4B, BE/BE4B, CE, and WRSR, WRCR, ERSCUR, PRSCUR, WREAR which are intended to change the device content, should be set every time after the WREN instruction setting the WEL bit.

The sequence of issuing WREN instruction is: CS# goes low → sending WREN instruction code → CS# goes high.

Figure 10-2 Write Enable (WREN) Sequence (Command 06H)

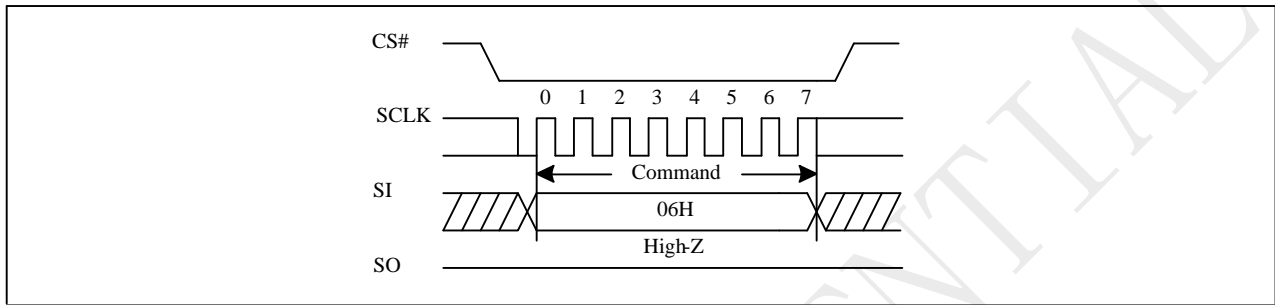
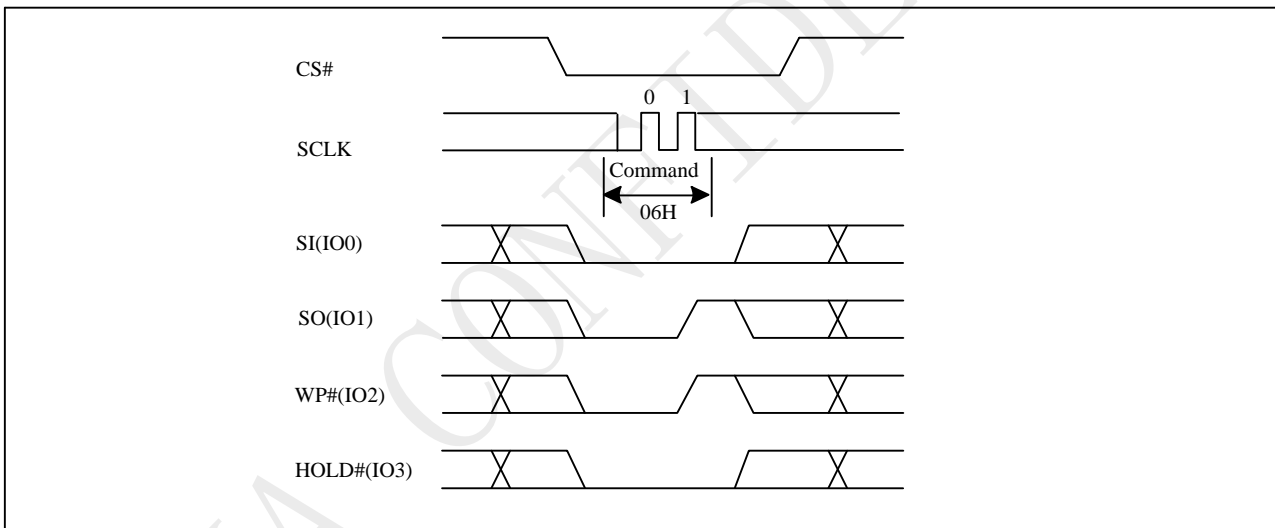

Figure 10-2a Write Enable (WREN) Sequence (QPI)



10.3 Write Disable (WRDI) (Command 04H)

The Write Disable (WRDI) instruction is for resetting Write Enable Latch (WEL) bit.

The sequence of issuing WRDI instruction is: CS# goes low → sending WRDI instruction code → CS# goes high.

The WEL bit is reset by following situations:

- Power-up
- Write Disable (WRDI) instruction completion
- Write Status Register (WRSR/WRCR) instruction completion
- Page Program (PP/PP4B) instruction completion
- Quad Page Program (QPP/QPP4B) instruction completion
- Quad-In Page Program (QIPP/QIPP4B) instruction completion
- Sector Erase (SE/SE4B) instruction completion
- Block Erase (BE32K/BE32K4B, BE/BE4B) instruction completion
- Chip Erase (CE) instruction completion
- SBLK/SBULK/GBLK/GBULK instruction completion
- Erase Security Register (ERSCUR) instruction completion
- Program Security Register (PRSCUR) instruction completion
- Reset (RST) instruction completion

Figure 10-3 Write Disable (WRDI) Sequence (Command 04)

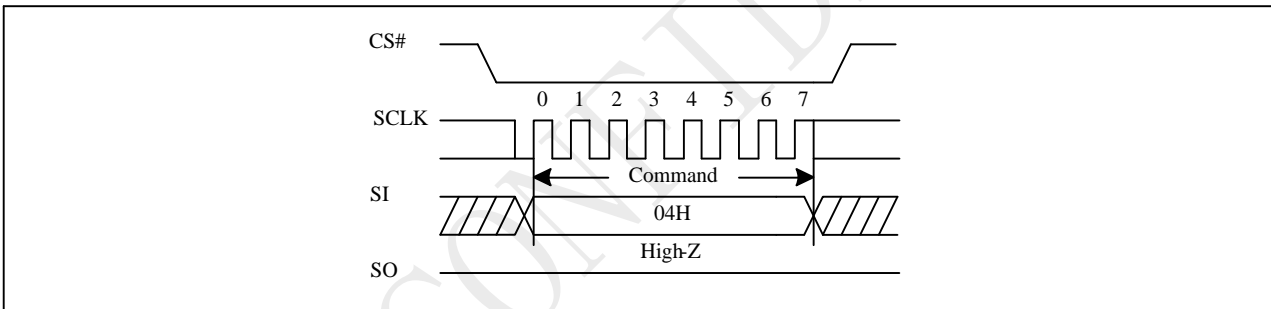
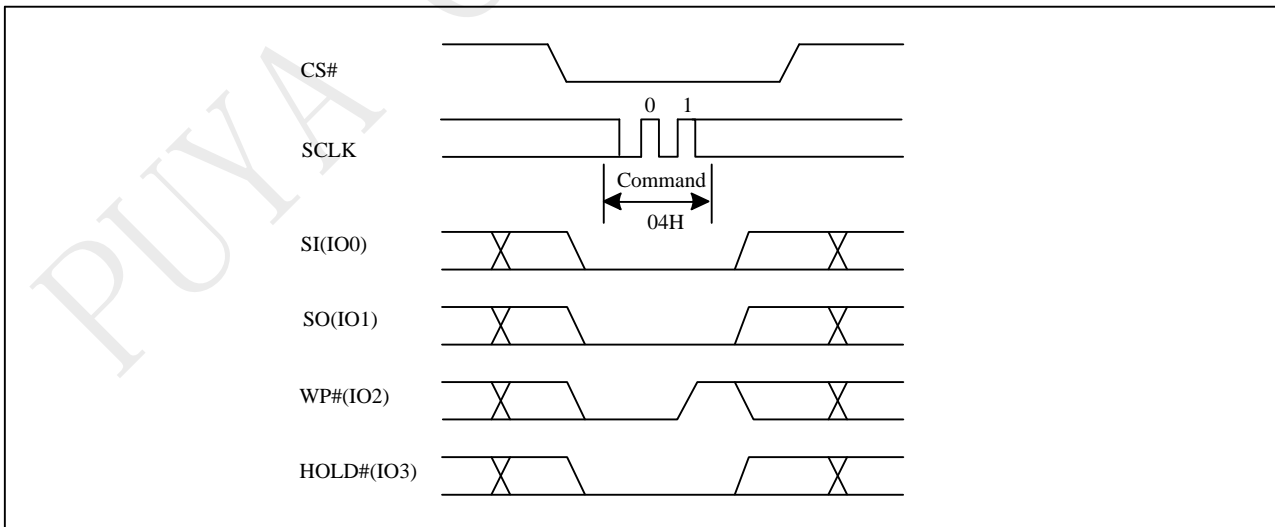

Figure 10-3a Write Disable (WRDI) Sequence (QPI)



10.4 Write Enable for Volatile Status Register (VWREN 50H)

The non-volatile Status Register bits can also be written to as volatile bits. This gives more flexibility to change the system configuration and memory protection schemes quickly without waiting for the typical non-volatile bit write cycles or affecting the endurance of the Status Register non-volatile bits. The Write Enable for Volatile Status Register command must be issued prior to a Write Status Register command. The Write Enable for Volatile Status Register command will not set the Write Enable Latch bit, it is only valid for the Write Status Register command to change the volatile Status Register bit values.

The sequence of issuing Write Enable for Volatile Status Register instruction is: CS# goes low → sending Write Enable for Volatile Status Register instruction code → CS# goes high.

Figure 10-4 Write Enable for Volatile Status Register Sequence (Command 50)

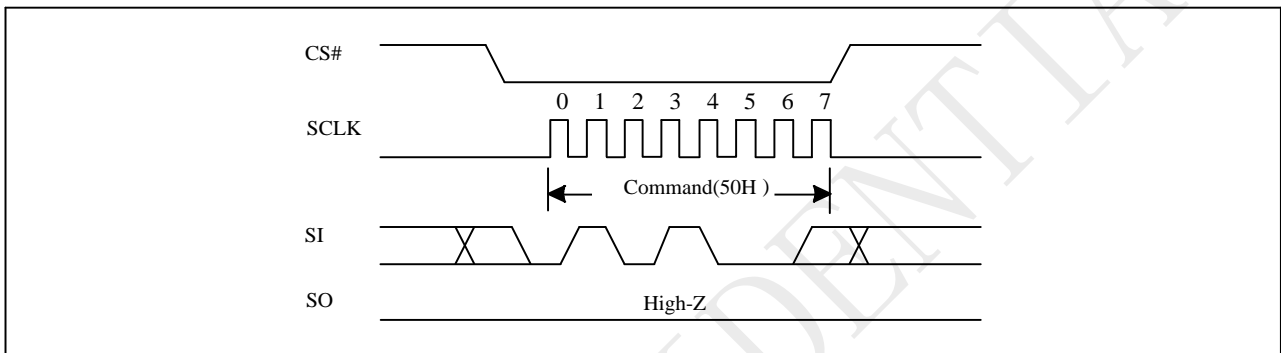
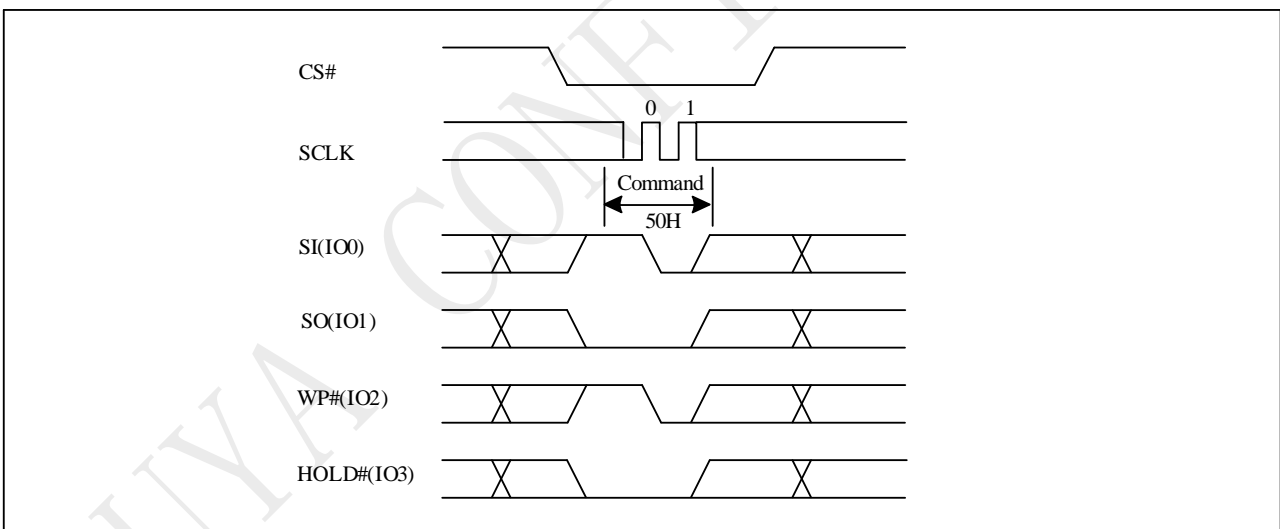

Figure 10-4a Write Enable for Volatile Status Register Sequence (QPI)



10.5 Read Status Register (RDSR 05H/35H)

The RDSR instruction is for reading Status Register Bits. The Read Status Register can be read at any time (even in program/erase/write status register condition). It is recommended to check the Write in Progress (WIP) bit before sending a new instruction when a program, erase, or write status register operation is in progress. For command code “05H”, the SO will output Status Register bits S7~S0. The command code “35H”, the SO will output Status Register bits S15~S8.

The sequence of issuing RDSR instruction is: CS# goes low→ sending RDSR instruction code→ Status Register data out on SO. The SIO[3:1] are "don't care".

Figure 10-5 Read Status Register (RDSR) Sequence (Command 05 or 35)

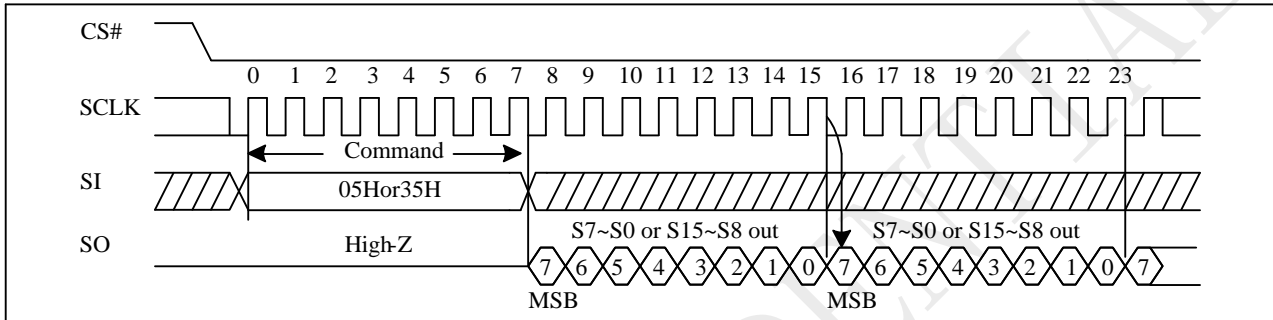
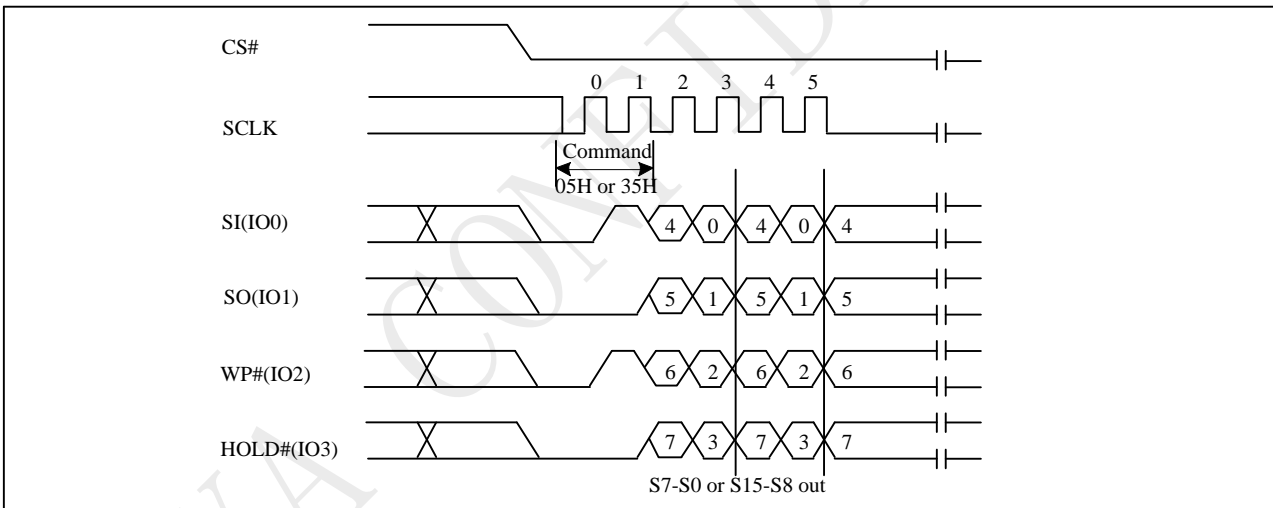

Figure 10-5a Read Status Register (RDSR) Sequence (QPI)



Status Register

BIT	S15	S14	S13	S12	S11	S10	S9	S8
Definition	SUS	CMP	LB3	LB2	LB1	EP_FAIL	QE	SRP1
Volatile	RO	N	OTP	OTP	OTP	RO	N	N
Default	0	0	0	0	0	0	0	0

BIT	S7	S6	S5	S4	S3	S2	S1	S0
Definition	SRP0	BP4	BP3	BP2	BP1	BP0	WEL	WIP
Volatile	N	N	N	N	N	N	V	RO
Default	0	0	0	0	0	0	0	0

Note:

1. RO=read only, N=non-volatile, V= volatile, OTP=one time program

The definition of the status register bits is as below:

**WIP bit.**

The Write in Progress (WIP) bit indicates whether the memory is busy in program/erase/write status register progress. When WIP bit sets to 1, means the device is busy in program/erase/write status register progress, when WIP bit sets 0, means the device is not in program/erase/write status register progress.

WEL bit.

The Write Enable Latch (WEL) bit indicates the status of the internal Write Enable Latch. When set to 1 the internal Write Enable Latch is set, when set to 0 the internal Write Enable Latch is reset and no Write Status Register, Program or Erase command is accepted.

BP4, BP3, BP2, BP1, BP0 bits.

The Block Protect (BP4, BP3, BP2, BP1, and BP0) bits are non-volatile. They define the size of the area to be software protected against Program and Erase commands. These bits are written with the Write Status Register (WRSR) command. When the Block Protect (BP4, BP3, BP2, BP1, BP0) bits are set to 1, the relevant memory area (as defined in Table "Protected Area Sizes").becomes protected against Page Program (PP), Page Erase (PE), Sector Erase (SE) and Block Erase (BE) commands. The Block Protect (BP4, BP3, BP2, BP1, and BP0) bits can be written provided that the Hardware Protected mode has not been set. The Chip Erase (CE) command is executed, only if the Block Protect (BP4, BP3, BP2, BP1 and BP0) are set to "None protected".

SRP1, SRP0 bits.

The Status Register Protect (SRP1 and SRP0) bits are non-volatile Read/Write bits in the status register. The SRP bits control the method of write protection: software protection, hardware protection, power supply lock-down or one time programmable protection

SRP1	SRP0	WP#	Status Register	Description
0	0	x	Software Protected	The Status Register can be written to after a Write Enable command, WEL=1.(Default)
0	1	0	Hardware Protected	WP#=0,the Status Register locked and cannot be written to.
0	1	1	Hardware Unprotected	WP#=1, the Status Register is unlocked and can be written to after a Write Enable command, WEL=1.
1	0	x	Power Supply Lock-Down(1)	Status Register is protected and cannot be written to again until the next Power-Down, Power-Up cycle.
1	1	x	One Time Program(2)	Status Register is permanently protected and cannot be written to.

NOTE:

1. When SRP1, SRP0= (1, 0), a Power-Down, Power-Up cycle will change SRP1, SRP0 to (0, 0) state.
2. This feature is available on special order. Please contact PUYA for details.

QE bit.

The Quad Enable (QE) bit is a non-volatile Read/Write bit in the Status Register that allows Quad operation. When the QE bit is set to 0 (Default) the WP# pin and HOLD# pin are enable. When the QE pin is set to 1, the Quad IO2 and IO3 pins are enabled. (The QE bit should never be set to 1 during standard SPI or Dual SPI operation if the WP# or HOLD# pins are tied directly to the power supply or ground)

EP_FAIL bit.

The Erase/Program Fail bit is a read only bit which shows the status of the last Program/Erase (PP, QPP, QIPP, SE, BE32K, BE, CE and ERSCUR, PRSCUR) operation. The bit will be set to "1" if the program/erase operation failed or interrupted by reset or the program/erase region was protected. It will be automatically cleared to "0" if the next program/erase operation succeeds. Please note that it will not interrupt or stop any operation in the flash memory.

LB3, LB2, LB1, bits.

The LB3, LB2, LB1, bits are non-volatile One Time Program (OTP) bits in Status Register (S13-S11) that provide the write protect control and status to the Security Registers. The default state of LB3-LB1 are 0, the security registers are unlocked. The LB3-LB1 bits can be set to 1 individually using the Write Register instruction. The LB3-LB1 bits are One Time Programmable, once its set to 1, the Security Registers will become read-only permanently.

CMP bit

The CMP bit is a non-volatile Read/Write bit in the Status Register (S14). It is used in conjunction the BP4-BP0 bits to provide more flexibility for the array protection. Please see the table "Protected Area Size" for details. The default setting is CMP=0.

SUS bit

The SUS bit is read only bit in the status register (S15) that is set to 1 after executing a Suspend (75H) command in Program/Erase progress. The SUS bit is cleared to 0 by Program/Erase Resume (7AH) command and a power-down power-up cycle, soft reset, hard reset.

10.6 Read Configure Register (RDCR 15H)

The RDCR instruction is for reading Configure Register Bits. The Read Configure Register can be read at any time (even in program/erase/write status register condition). It is recommended to check the Write in Progress (WIP) bit before sending a new instruction when a program, erase, or write status register operation is in progress.

The sequence of issuing RDCR instruction is: CS# goes low → sending RDCR instruction code → Configure Register data out on SO. The SIO[3:1] are "don't care" in SPI mode.

Figure 10-6 Read Status Register (RDCR) Sequence (Command 15)

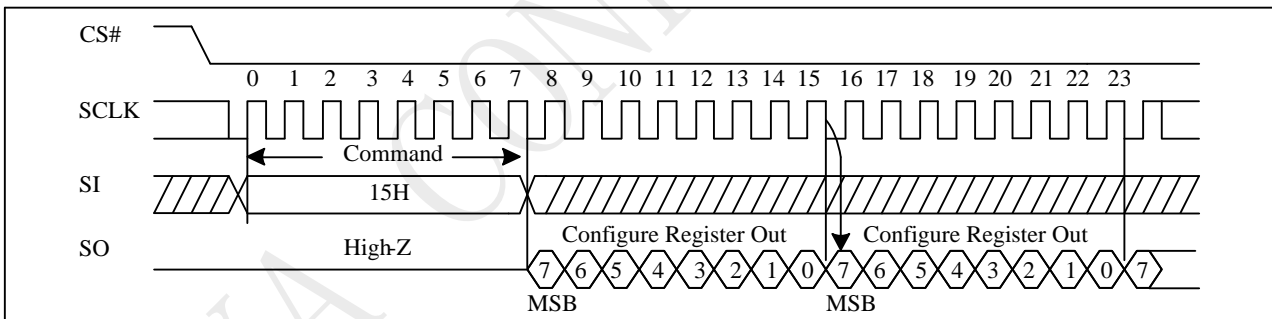
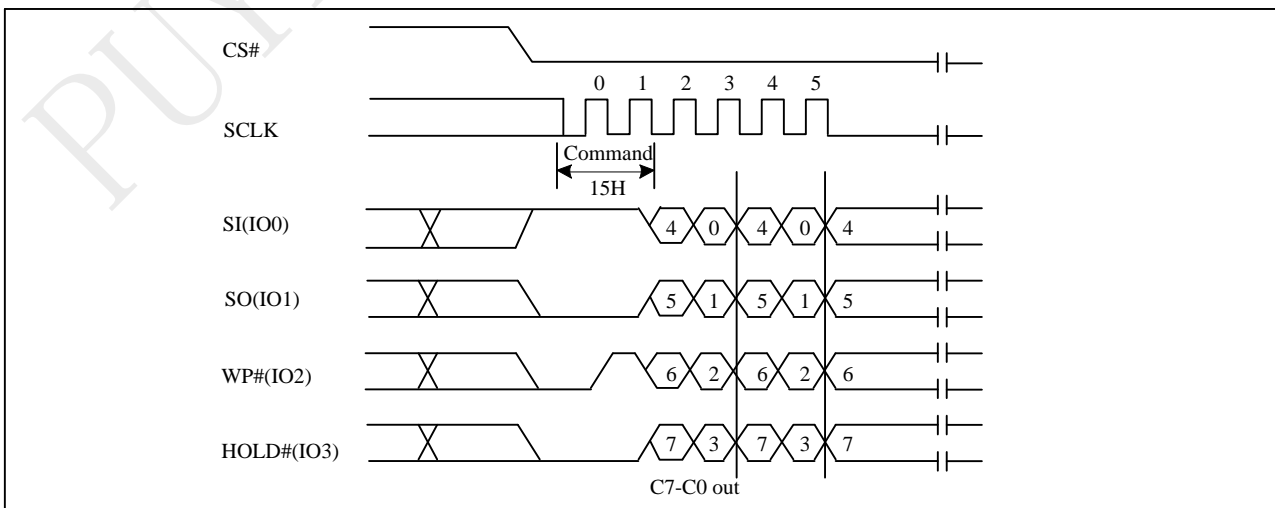

Figure 10-6a Read Status Register (RDCR) Sequence (QPI)



**Configure Register**

BIT	Bit7	Bit6	Bit5	Bit4	Bit3	Bit2	Bit1	Bit0
Definition	HOLD/RST	DRV1	DRV0	DLP	DC	WPS	ADP	ADS
Type	N	N	N	V	V	N	N	RO
Default	0	0	0	0	0	0	0	0

Note: RO=read only, N=non-volatile, V= volatile

HOLD/RST bit.

The HOLD/RST bit is a non-volatile Read/Write bit which is used to determine whether /HOLD or /RESET function should be implemented on the hardware pin for 8-pin packages. When HOLD/RST=0 (factory default), the pin acts as /HOLD; when HOLD/RST=1, the pin acts as /RESET. However, /HOLD or /RESET functions are only available when QE=0. If QE is set to 1, the /HOLD and /RESET functions are disabled, the pin acts as a dedicated data I/O pin.

DRV1 & DRV0 bit.

The DRV1 & DRV0 bits are non-volatile Read/Write bits which are used to determine the output driver strength for the Read operations.

DRV1, DRV0	Drive Strength
0,0(default)	100%
0,1	67%
1,0	133%
1,1	167%

DLP bit.

The DLP bit is Data Learning Pattern Enable bit, which is volatile writable by 11H command. For DTR Read commands, a pre-defined "Data Learning Pattern" can be used by the flash memory controller to determine the flash data output timing on I/O pins. When DLP=1, in dummy cycles, the flash will output "00110100" Data Learning Pattern sequence on each of the I/O pins. During this period, controller can fine tune the data latching timing for each I/O pins to achieve optimum system performance. DLP=0(default) will disable the Data Learning Pattern output.

DC bit

The Dummy Cycle (DC) bit is a volatile bit. The Dummy Cycle (DC) bit can be used to configure the number of dummy clocks for "SPI 2 X IO Read (BBH/BCH)" command, "SPI 4X I/O Read (EBH/ECH)" command, "DTR 2IO read(BDH)", "DTR 4IO read(EDH/EEH)", and "DTR Burst Read with Wrap(0EH)".

Table Dummy Cycle Table

Mode	Command	DC bit	Number of dummy cycles
SPI mode	BBH/BCH	0(default)	4
		1	8
	EBH/ECH	0(default)	6
		1	10
	BDH	0(default)	6
		1	8
	EDH/EEH	0(default)	8
		1	10
QPI mode	0DH/EDH/EEH/0EH	0(default)	8
		1	10

WPS bit.

The WPS bit is a non-volatile Read/Write bit which is used to select which Write Protect scheme should be used. When WPS=0(default), the device will use the combination of CMP, BP[4:0] bits to protect a specific area of the memory array. When WPS=1, the device will utilize the Individual Block Locks to protect any



individual sector or blocks. The default value for all Individual Block Lock bits is 1 upon device power on or after reset.

ADP bit.

The ADP bit is a non-volatile Read/Write bit that determines the initial address mode when the device is powered on or reset. This bit is only used during the power on or device reset initialization period, and it is only writable by the non-volatile Write Status sequence (06h + 11h). When ADP=0 (factory default), the device will power up into 3-Byte Address Mode, the Extended Address Register must be used to access memory regions beyond 128Mb. When ADP=1, the device will power up into 4-Byte Address Mode directly.

ADS bit.

The Current Address Mode bit is a read only bit that indicates which address mode the device is currently operating in. When ADS=0, the device is in the 3-Byte Address Mode, when ADS=1, the device is in the 4-Byte Address Mode.

10.7 Write Status Register (WRSR 01H/31H)

The Write Status Register (WRSR) command allows new values to be written to the Status Register. Before it can be accepted, a Write Enable (WREN) command must previously have been executed. After the Write Enable (WREN) command has been decoded and executed, the device sets the Write Enable Latch (WEL).

The Write Status Register (WRSR) command has no effect on S15, S10, S1 and S0 of the Status Register. CS# must be driven high after the eighth or sixteen bit of the data byte has been latched in. If not, the Write Status Register (WRSR) command is not executed. If CS# is driven high after eighth bit of the data byte, the S15~S8 bits will keep the previous value. As soon as CS# is driven high, the self-timed Write Status Register cycle (whose duration is tW) is initiated. While the Write Status Register cycle is in progress, the Status Register may still be read to check the value of the Write In Progress (WIP) bit. The Write In Progress (WIP) bit is 1 during the self-timed Write Status Register cycle, and is 0 when it is completed. When the cycle is completed, the Write Enable Latch (WEL) is reset.

The Write Status Register (WRSR) command allows the user to change the values of the Block Protect (BP4, BP3, BP2, BP1, and BP0) bits, to define the size of the area that is to be treated as read-only, as defined in Table1. The Write Status Register (WRSR) command also allows the user to set or reset the Status Register Protect (SRP1 and SRP0) bits in accordance with the Write Protect (WP#) signal. The Status Register Protect (SRP1 and SRP0) bits and Write Protect (WP#) signal allow the device to be put in the Hardware Protected Mode. The Write Status Register (WRSR) command is not executed once the Hardware Protected Mode is entered.

The sequence of issuing WRSR instruction is: CS# goes low→ sending WRSR instruction code→ Status Register data on SI→CS# goes high.

The CS# must go high exactly at the 8 bits data boundary; otherwise, the instruction will be rejected and not executed. The self-timed Write Status Register cycle time (tW) is initiated as soon as Chip Select (CS#) goes high. The Write in Progress (WIP) bit still can be checked during the Write Status Register cycle is in progress. The WIP sets 1 during the tW timing, and sets 0 when Write Status Register Cycle is completed, and the Write Enable Latch (WEL) bit is reset.

Figure 10-7 Write Status Register (WRSR) Sequence (Command 01 or 31)

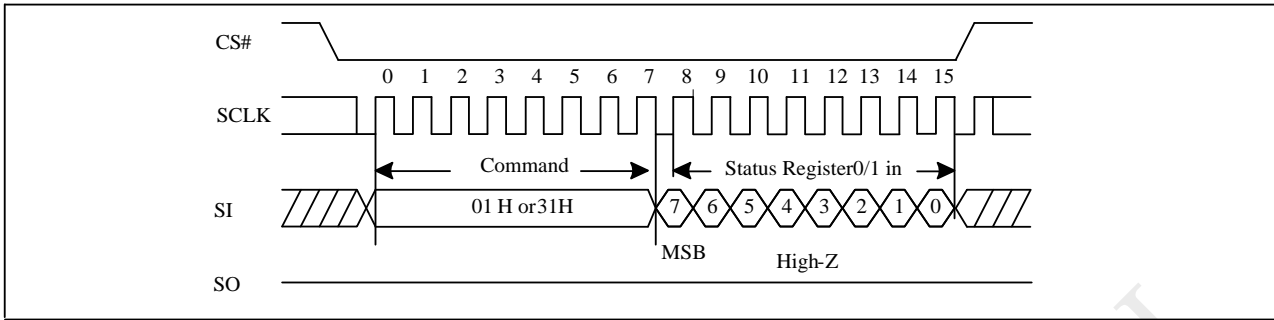
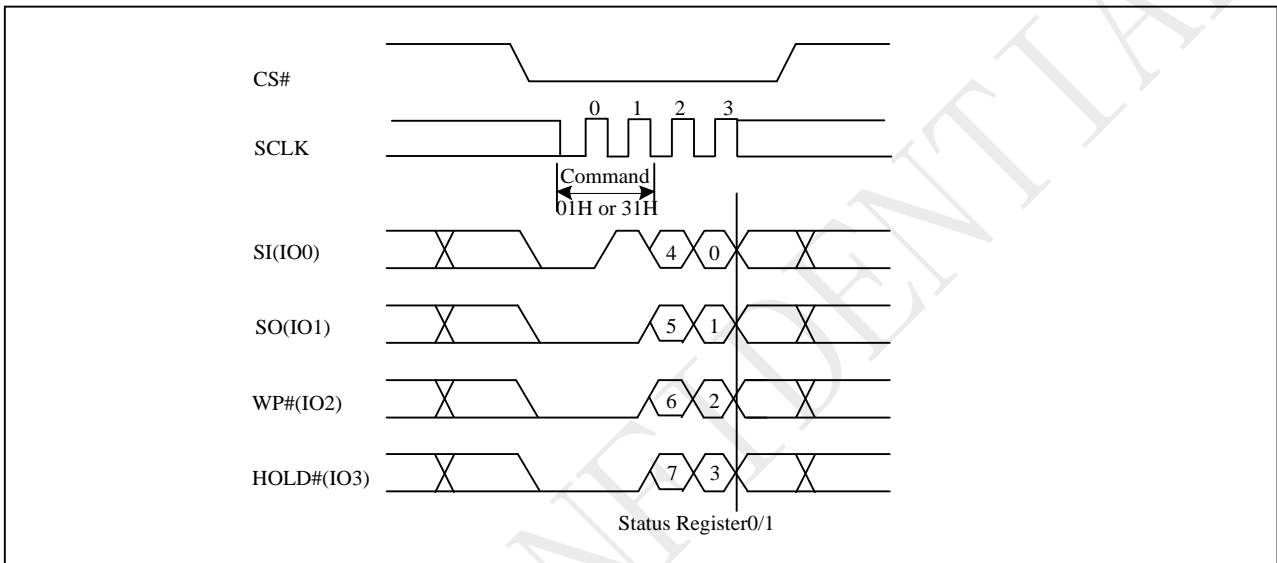

Figure 10-7a Write Status Register (WRSR) Sequence (QPI)



To be backward compatible to Puya's previous serial flash product, The Write Status Register (WRSR) command also support to write Status Register-0 and Status Register-1 in same time. To complete this function, CS# must be driven high after the sixteenth bit of the data byte has been latched in. If CS# is driven high after the eighth clock, the Write Status Register (01h) command will only program the Status Register-0, the Status Register-1 will not be affected (Previous product will clear CMP and QE bits).

Figure 10-7b Write Status Register (WRSR) with 2 Byte data Sequence (SPI)

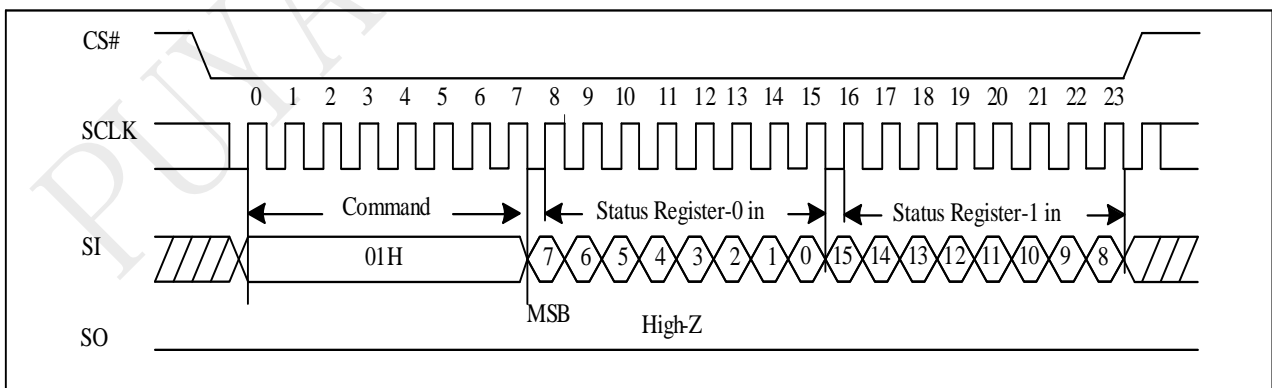
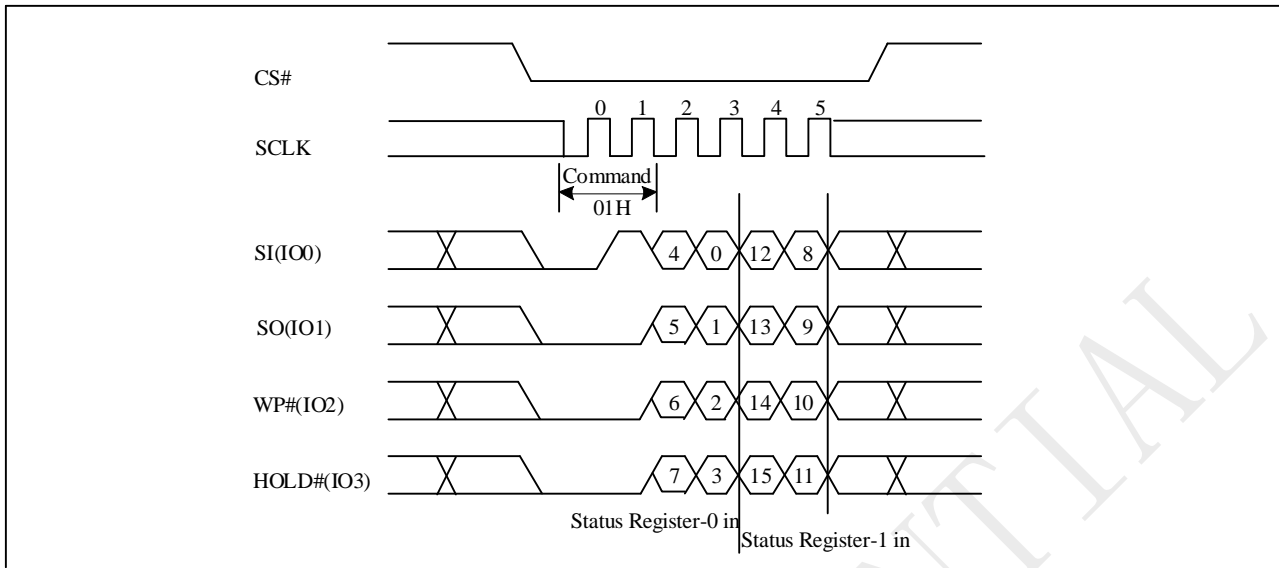

Figure 10-7c Write Status Register (WRSR) with 2 Byte data Sequence (QPI)



10.8 Write Configure Register (WRCR 11H)

The Write Configure Register (WRCR) command allows new values to be written to the Configure Register. Before it can be accepted, a Write Enable (WREN) command must previously have been executed. After the Write Enable (WREN) command has been decoded and executed, the device sets the Write Enable Latch (WEL).

The sequence of issuing WRCR instruction is: CS# goes low → sending WRCR instruction code → Configure Register data on SI → CS# goes high.

The CS# must go high exactly at the 8 bits data boundary; otherwise, the instruction will be rejected and not executed. The self-timed Write Status Register cycle time (tW) is initiated as soon as Chip Select (CS#) goes high. The Write in Progress (WIP) bit still can be checked during the Write Status Register cycle is in progress. The WIP sets 1 during the tW timing, and sets 0 when Write Configure Register Cycle is completed, and the Write Enable Latch (WEL) bit is reset.

Figure 10-8 Write Configure Register (WRCR) Sequence (Command 11)

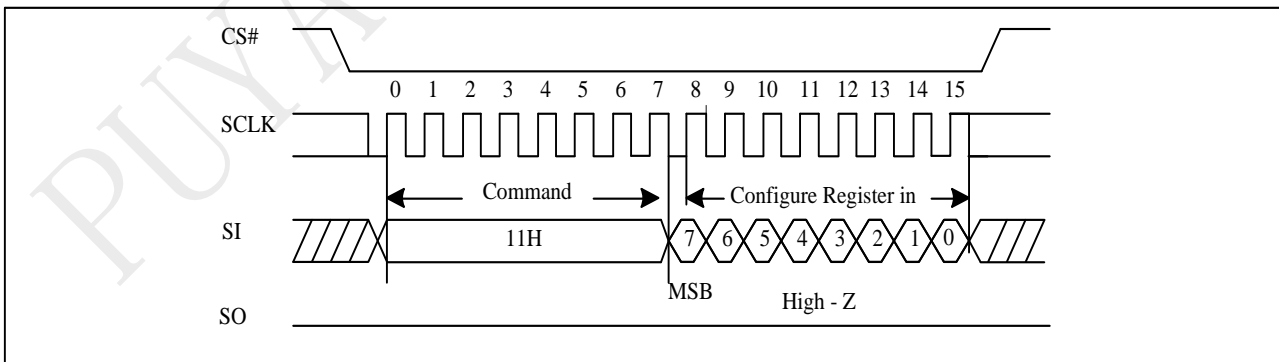
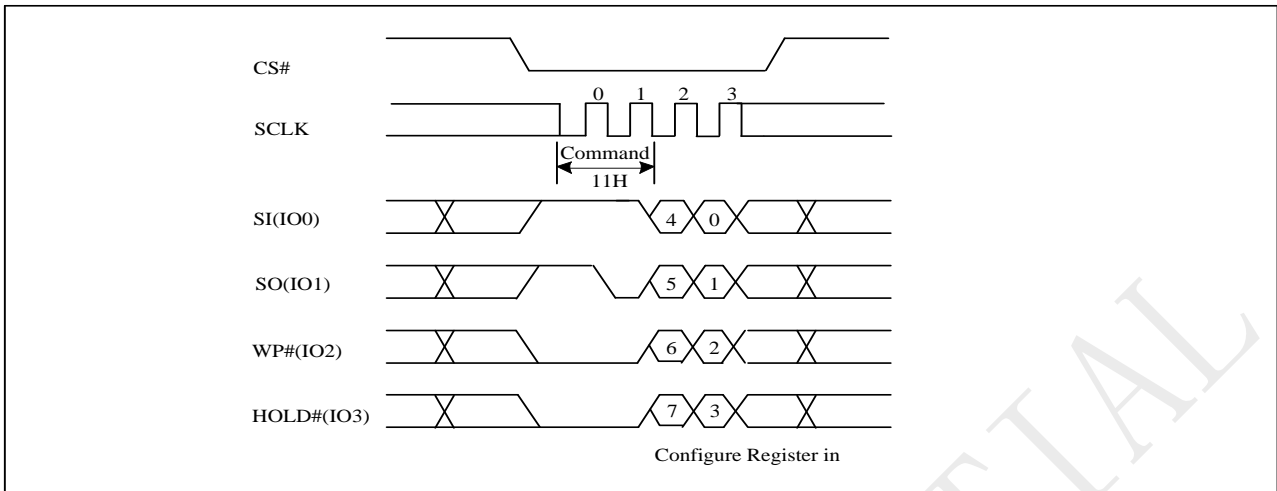

Figure 10-8a Write Configure Register (WRCR) Sequence (QPI)



10.9 Read Extended Address Register (RDEAR C8H)

When the device is in the 3-Byte Address Mode, the Extended Address Register is used as the 4th address byte A[31:24] to access memory regions beyond 128Mb.

The Read Extended Address Register instruction is entered by driving CS# low and shifting the instruction code "C8h" into the SI pin on the rising edge of SCLK. The Extended Address Register bits are then shifted out on the SO pin at the falling edge of SCLK with most significant bit (MSB) first.

When the device is in the 4-Byte Address Mode, the Extended Address Register is not used.

Figure 10-9 Read Extended Address Register Sequence (Command C8)

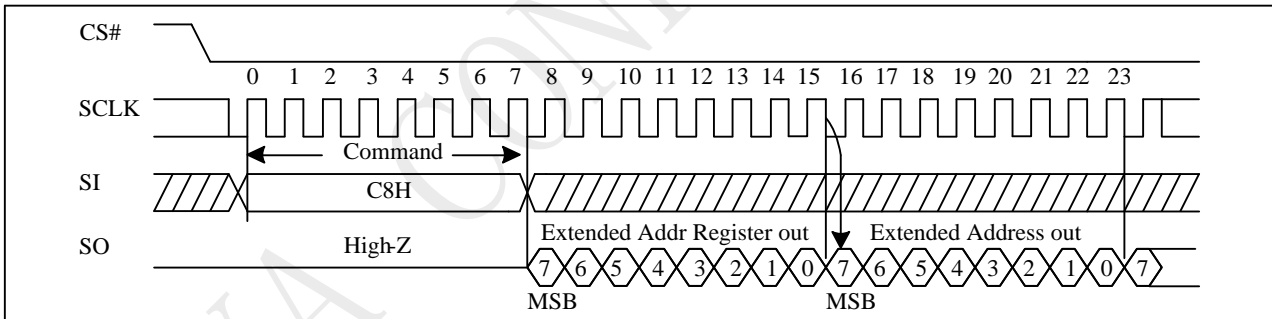
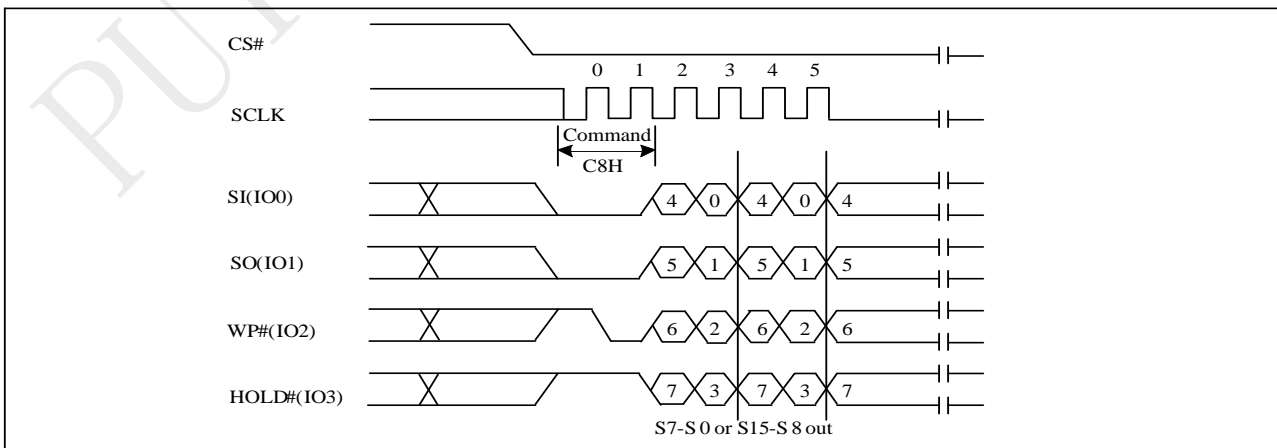

Figure 10-9a Read Extended Address Register Sequence (QPI)



**Extend Address Register**

EA	EA7	EA6	EA5	EA4	EA3	EA2	EA1	EA0
Definition	Reserved	Reserved	Reserved	Reserved	Reserved	Reserved	A25	A24
Type	-	-	-	-	-	-	Volatile	Volatile
Default	0	0	0	0	0	0	0	0

A25-A24 bit.

The Extended Address Bit A25-A24 is used only when the device is operating in the 3-Byte Address Mode (ADS=0), which is volatile writable by C5H command.

Figure 10-9b. EAR Operation Segments

A25-A24	DIE	Address
00	0	0000_0000H – 00FF_FFFFH
01	0	0100_0000H – 01FF_FFFFH
10	1	0200_0000H – 02FF_FFFFH
11	1	0300_0000H – 03FF_FFFFH

10.10 Write Extended Address Register (WREAR C5H)

The Extended Address Register is a volatile register that stores 4th byte address (A31-A24) When the device is operating in the 3-Byte Address Mode (ADS=0). To write the Extended Address Register bits, a Write Enable (06h) instruction must previously have been executed for the device to accept the Write Extended Address Register instruction (Status Register bit WEL must equal 1). Once write enabled, the instruction is entered by driving CS# low, sending the instruction code “C5h”, and then writing the Extended Address Register data byte.

Upon power up or the execution of a Software/Hardware Reset, the Extended Address Register bit values will be cleared to 0.

The Extended Address Register is only effective when the device is in the 3-Byte Address Mode. When the device operates in the 4-Byte Address Mode (ADS=1), any command with address input of A31-A24 will replace the Extended Address Register values. It is recommended to check and update the Extended Address Register if necessary when the device is switched from 4-Byte to 3-Byte Address Mode.

Figure 10-10 Write Extended Address Register Sequence (Command C5)

Figure 10-10a Write Extended Address Register Sequence (QPI)



10.11 Enter 4-Byte Address Mode (B7H)

The Enter 4-Byte Address Mode instruction will allow 32-bit address (A31-A0) to be used to access the memory array beyond 128Mb. The Enter 4-Byte Address Mode instruction is entered by driving CS# low, shifting the instruction code “B7h” into the SI pin and then driving CS# high.

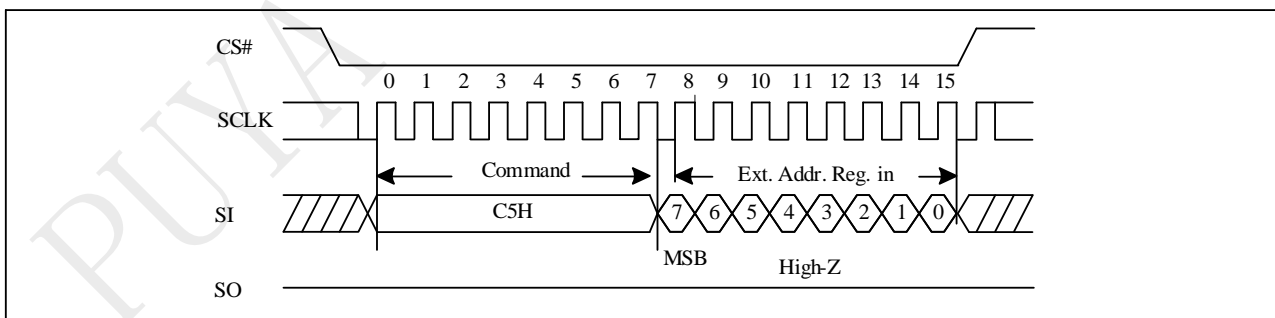
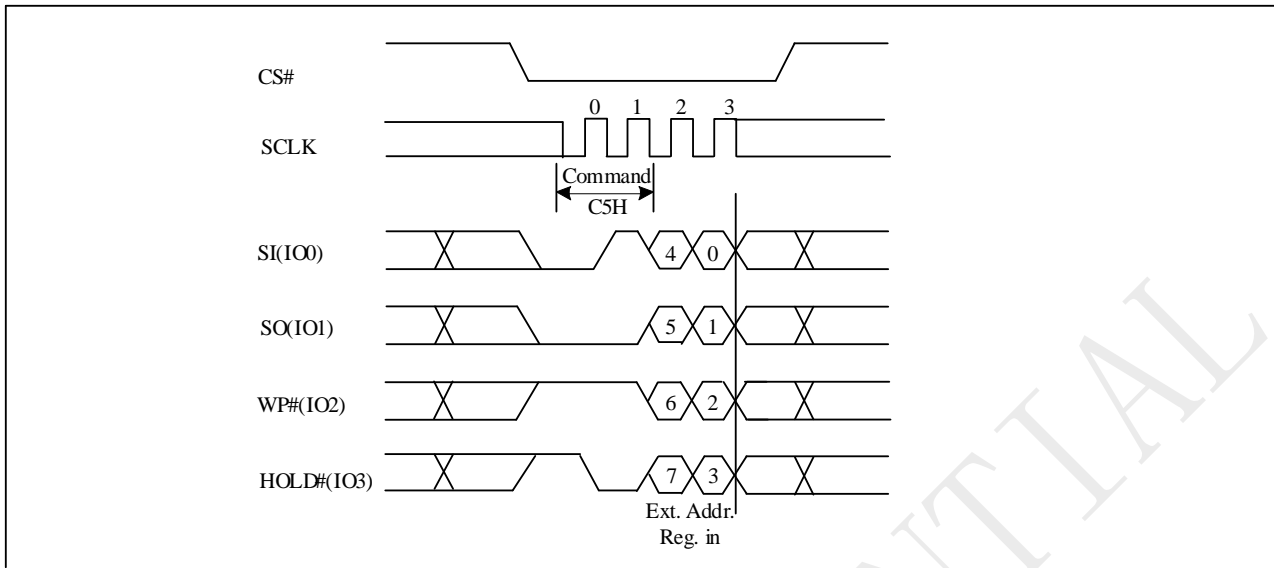
Figure 10-11 Enter 4-Byte Address Mode Sequence (Command B7)

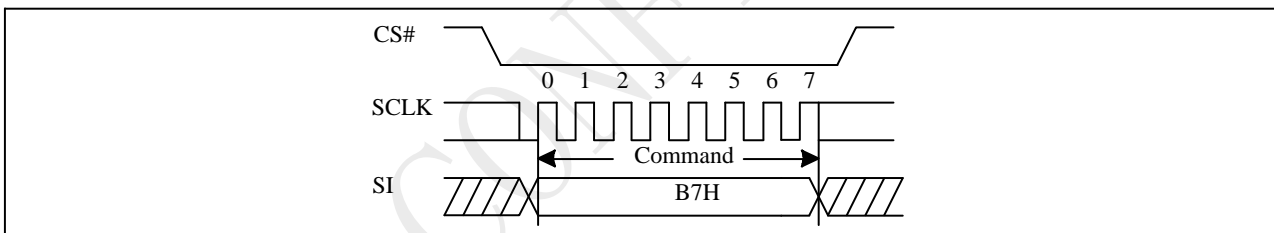
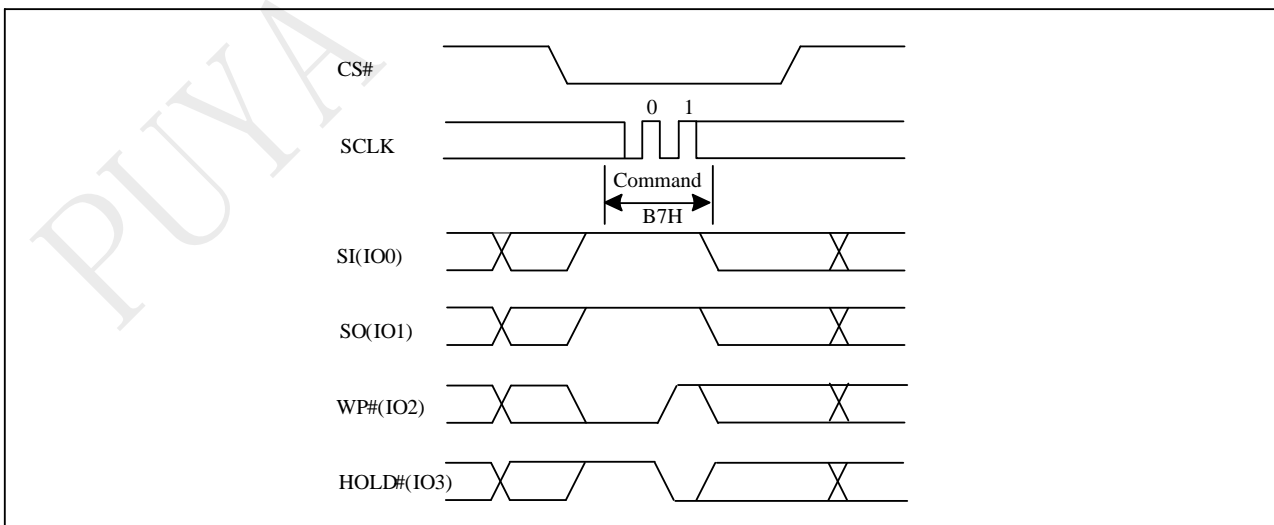

Figure 10-11a Enter 4-Byte Address Mode Sequence (QPI)



10.12 Exit 4-Byte Address Mode (E9H)

In order to be backward compatible, the Exit 4-Byte Address Mode instruction will only allow 24-bit address (A23-A0) to be used to access the memory array up to 128Mb. The Extended Address Register must be used to access the memory array beyond 128Mb. The Exit 4-Byte Address Mode instruction is entered by driving CS# low, shifting the instruction code “E9h” into the SI pin and then driving CS# high.

Figure 10-12 Exit 4-Byte Address Mode Sequence (Command E9)

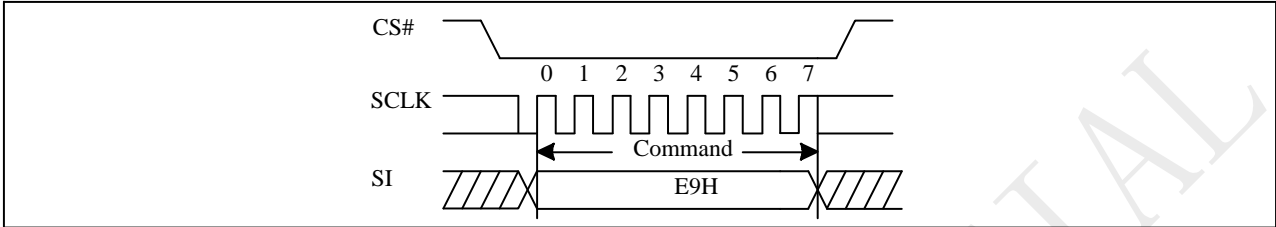
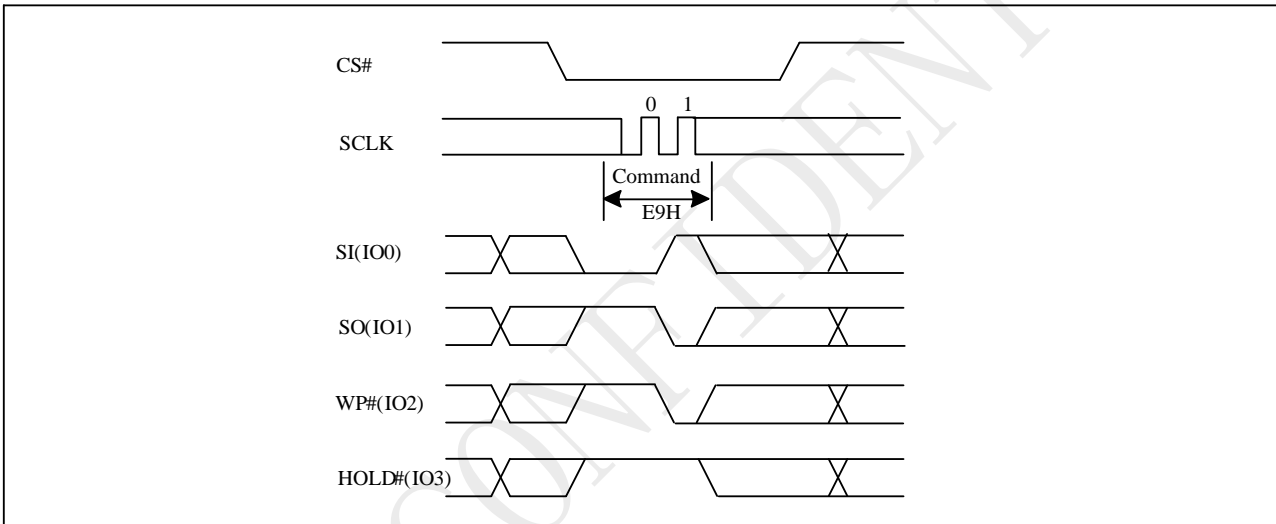

Figure 10-12a Exit 4-Byte Address Mode Sequence (QPI)



10.13 Read Data Bytes (READ 03H)

The Read Data instruction allows one or more data bytes to be sequentially read from the memory. The instruction is initiated by driving the CS# pin low and then shifting the instruction code “03h” followed by a 32/24-bit address (A31/A23-A0) into the SI pin. The code and address bits are latched on the rising edge of the SCLK pin. After the address is received, the data byte of the addressed memory location will be shifted out on the SO pin at the falling edge of SCLK with most significant bit (MSB) first. The address is automatically incremented to the next higher address after each byte of data is shifted out allowing for a continuous stream of data. This means that the entire memory can be accessed with a single instruction as long as the clock continues. The instruction is completed by driving CS# high.

If a Read Data instruction is issued while an Erase, Program or Write cycle is in process (BUSY=1) the instruction is ignored and will not have any effects on the current cycle.

Figure 10-13 Read Data Bytes (READ) Sequence (Command 03)

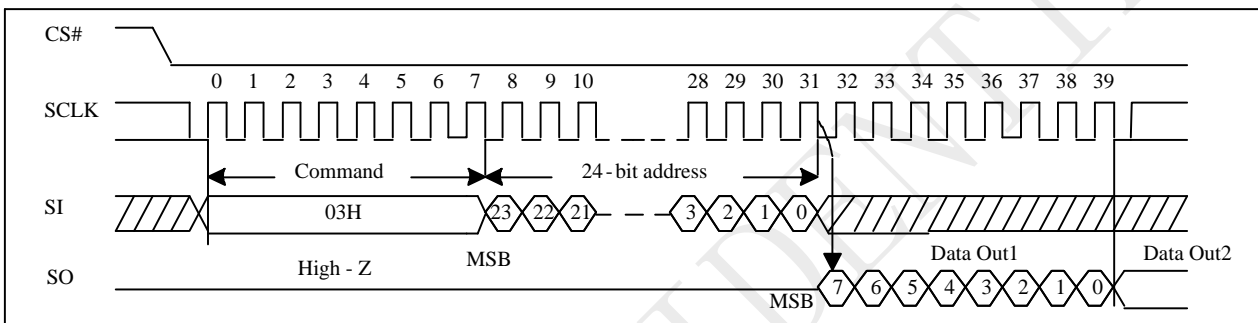

Note: 32-bit address is required when the device is operation in 4-byte address mode.

10.14 Read Data Bytes with 4-Byte Address (READ4B 13H)

The Read Data with 4-Byte Address instruction is similar to the Read Data (03h) instruction. Instead of 24-bit address, 32-bit address is needed following the instruction code 13h. No matter the device is operating in 3-Byte Address Mode or 4-byte Address Mode, the Read Data with 4-Byte Address instruction will always require 32-bit address to access the entire 512Mb memory.

If this instruction is issued while an Erase, Program or Write cycle is in process (BUSY=1) the instruction is ignored and will not have any effects on the current cycle.

Figure 10-14 Read Data Bytes with 4-Byte Address Sequence (Command 13)

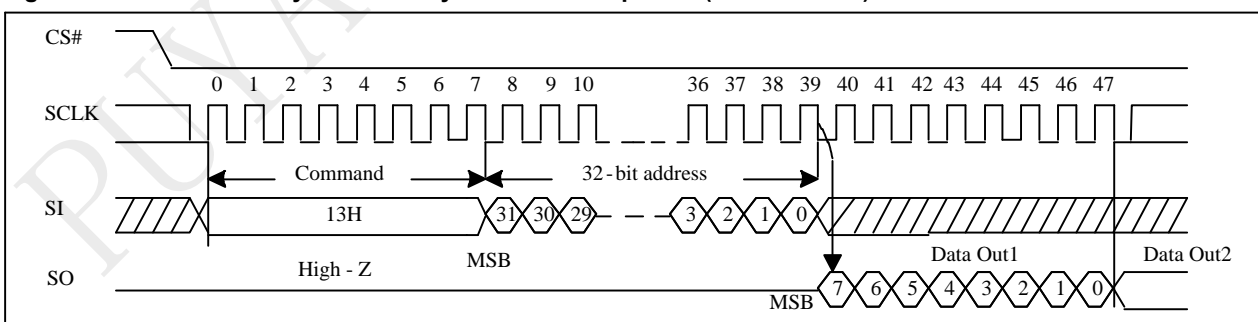

10.15 Fast Read (FREAD 0BH)

The FASTREAD instruction is similar to the Read Data instruction except that it can quickly reading data out. The 24/32-bit address is latched on rising edge of SCLK, and data of each bit shifts out on the falling edge of SCLK at a maximum frequency f_C . The first address byte can be at any location. The address is automatically increased to the next higher address after each byte data is shifted out, so the whole memory can be read out at a single FREAD instruction. The address counter rolls over to 0 when the highest address has been reached.

While Program/Erase/Write Status Register cycle is in progress, FREAD instruction is rejected without any impact on the Program/Erase/Write Status Register current cycle.

Figure 10-15 Fast Read (FREAD) Sequence (Command 0B)

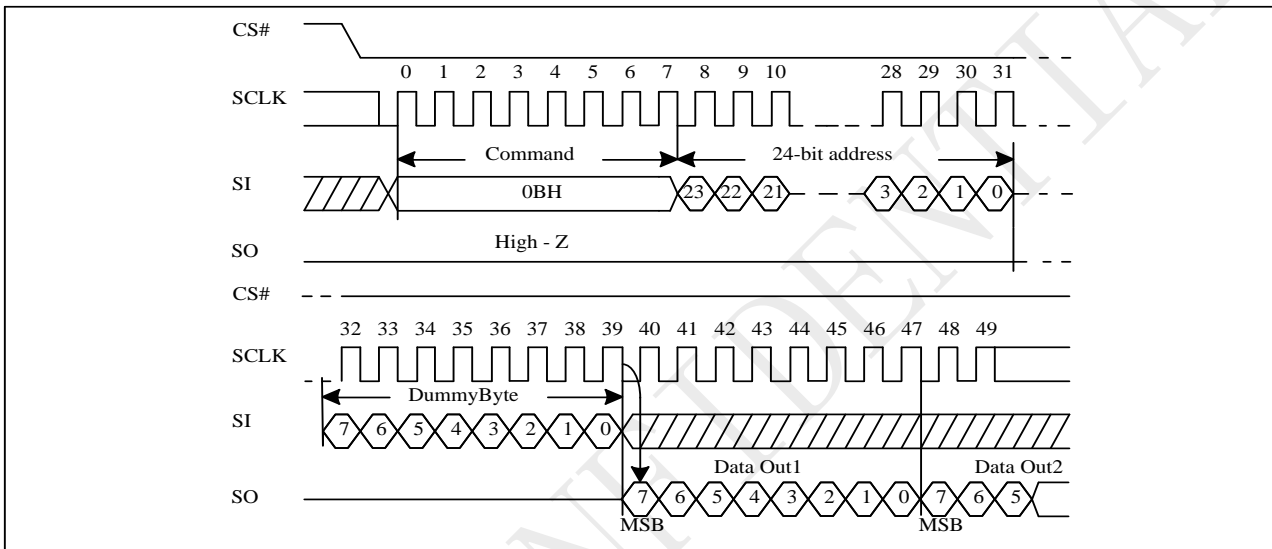

Note: 32-bit address is required when the device is operation in 4-byte address mode.

Fast Read in QPI mode

The Fast Read command is also supported in QPI mode. In QPI mode, the number of dummy clocks is configured by the “Set Read Parameters (C0H)” command to accommodate a wide range application with different needs for either maximum Fast Read frequency or minimum data access latency. Depending on the Read Parameter Bits P[5:4] setting, the number of dummy clocks can be configured as either 10/4/6/8.

Figure 10-15a Fast Read Sequence (QPI)

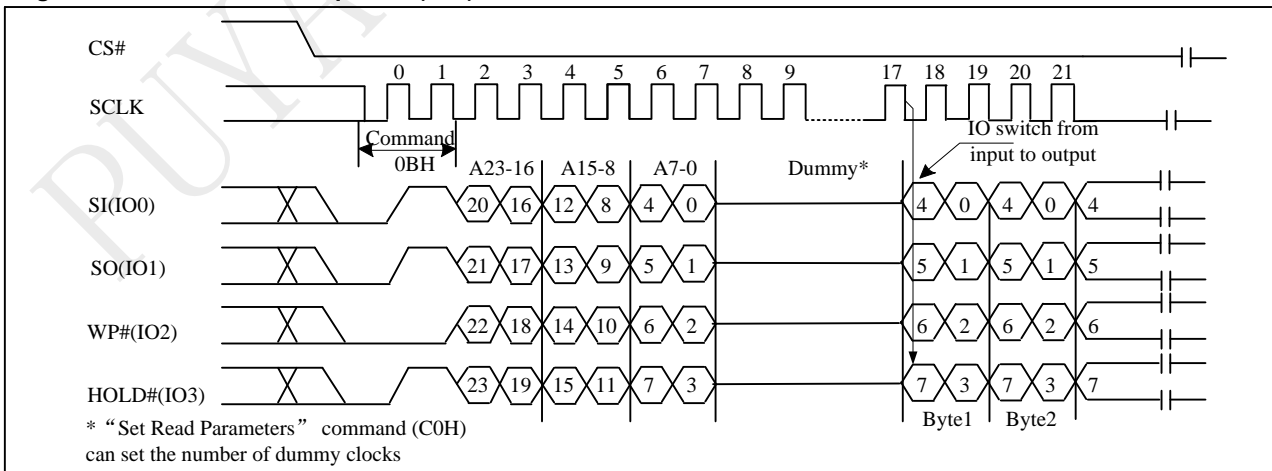

Note:

1. 32-bit address is required when the device is operation in 4-byte address mode.
2. C0H command can set the number of dummy clocks.

10.16 DTR Fast Read (DTR_FREAD 0DH)

The DTR Fast Read instruction is similar to the Fast Read instruction except that the 24/32-bit address input and the data output require DTR (Double Transfer Rate) operation. This is accomplished by adding six “dummy” clocks after the 24/32-bit address. The dummy clocks allow the devices internal circuits additional time for setting up the initial address. During the dummy clocks the data value on the DO pin is a “don’t care”.

Figure 10-16 DTR Fast Read Sequence (Command 0D)

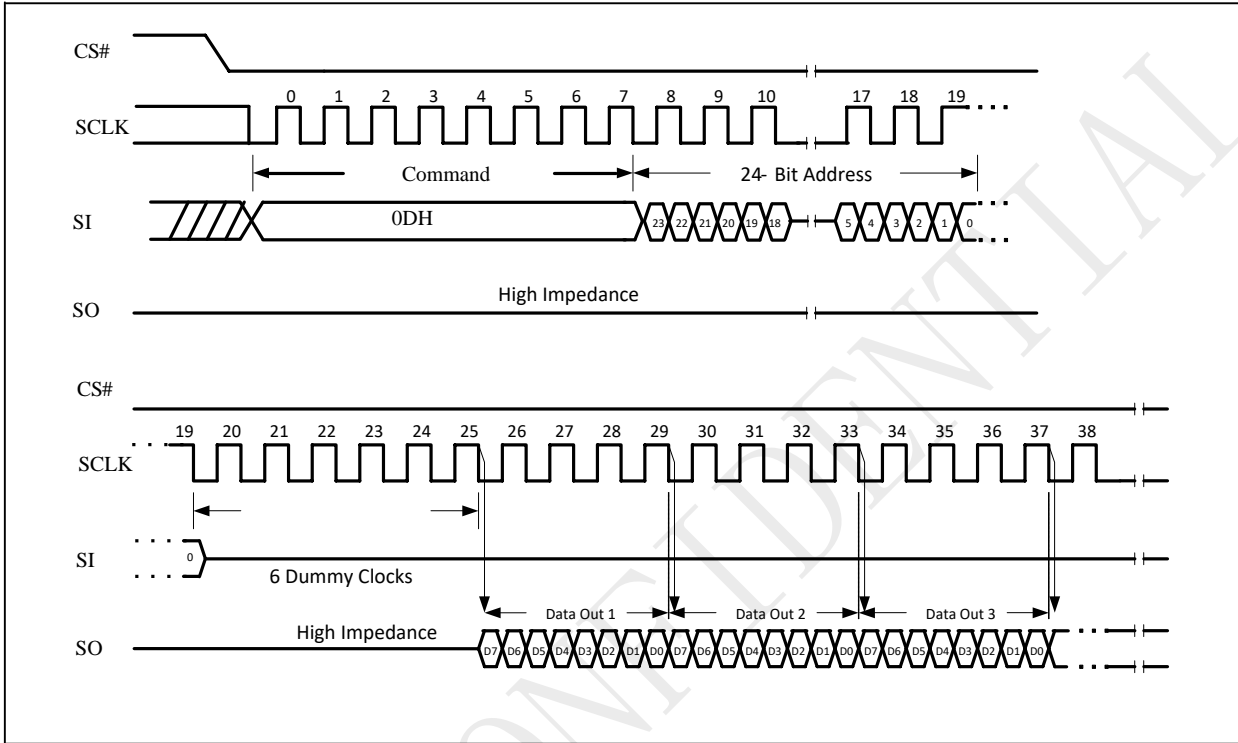

Note: 32-bit address is required when the device is operation in 4-byte address mode.

DTR Fast Read in QPI Mode

The DTR Fast Read instruction is also supported in QPI mode.

Figure 10-16a DTR Fast Read Sequence (QPI)

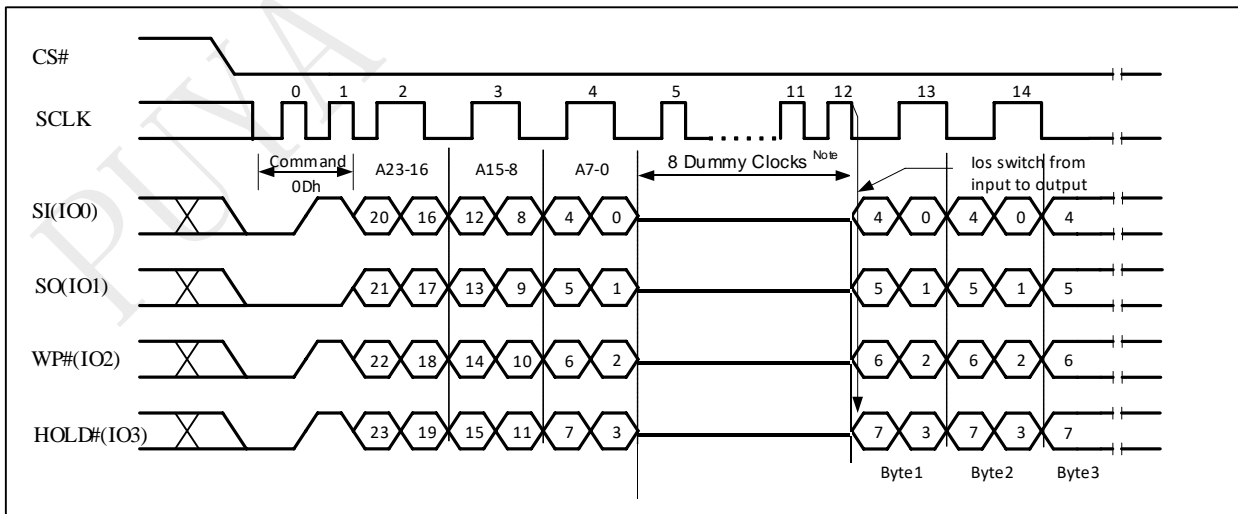

Note: 32-bit address is required when the device is operation in 4-byte address mode.

When DC bit set to 1; 0DH in QPI with 10 Dummy Clocks.

10.17 Fast Read with 4-Byte Address (FREAD 0CH)

The Fast Read with 4-Byte Address instruction is similar to the Fast Read instruction except that it requires 32-bit address instead of 24-bit address. No matter the device is operating in 3-Byte Address Mode or 4-byte Address Mode, the Read Data with 4-Byte Address instruction will always require 32-bit address to access the entire 512Mb memory.

The Fast Read with 4-Byte Address (0Ch) instruction is only supported in Standard SPI mode. In QPI mode, the instruction code 0Ch is used for the “Burst Read with Wrap” instruction.

Figure 10-17 Fast Read with 4-Byte Address Sequence (Command 0C)

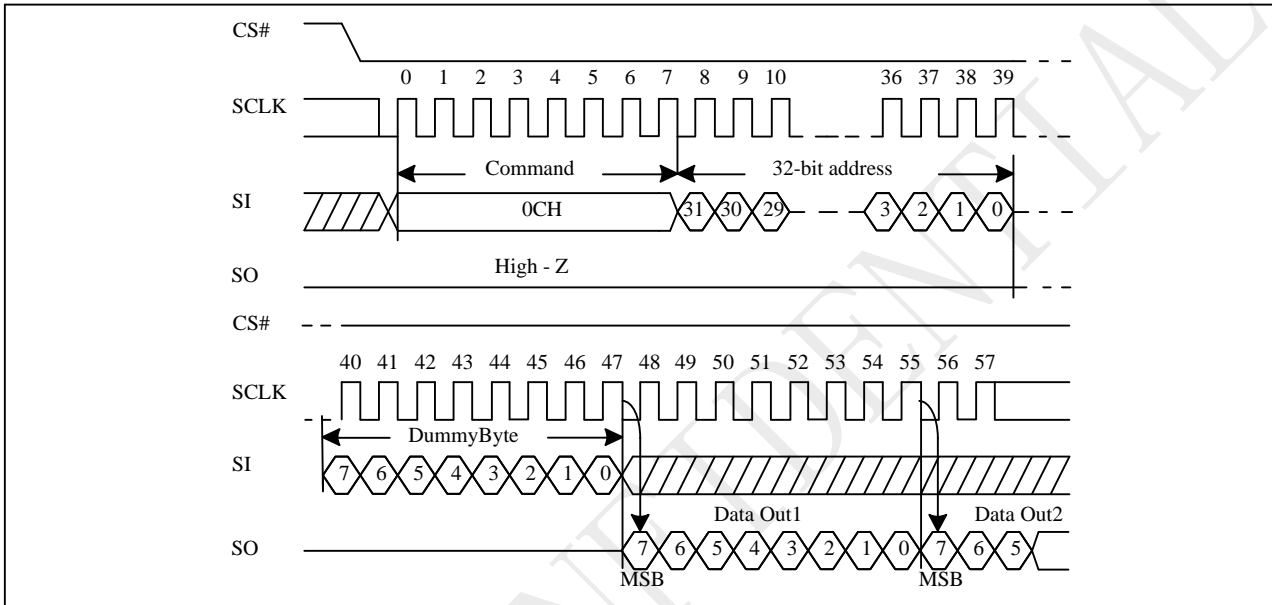

10.18 Dual Read (DREAD 3BH)

The DREAD instruction enable double throughput of Serial NOR Flash in read mode. The address is latched on rising edge of SCLK, and data of every two bits (interleave on 2 I/O pins) shift out on the falling edge of SCLK at a maximum frequency f_T . The first address byte can be at any location. The address is automatically increased to the next higher address after each byte data is shifted out, so the whole memory can be read out at a single DREAD instruction. The address counter rolls over to 0 when the highest address has been reached. Once writing DREAD instruction, the following data out will perform as 2-bit instead of previous 1-bit.

The sequence of issuing DREAD instruction is: CS# goes low → sending DREAD instruction → 3/4-byte address on SI → 8-bit dummy cycle → data out interleave on SIO1 & SIO0 → to end DREAD operation can use CS# to high at any time during data out.

While Program/Erase/Write Status Register cycle is in progress, DREAD instruction is rejected without any impact on the Program/Erase/Write Status Register current cycle.

Figure 10-18 Dual Read Mode Sequence (Command 3B)

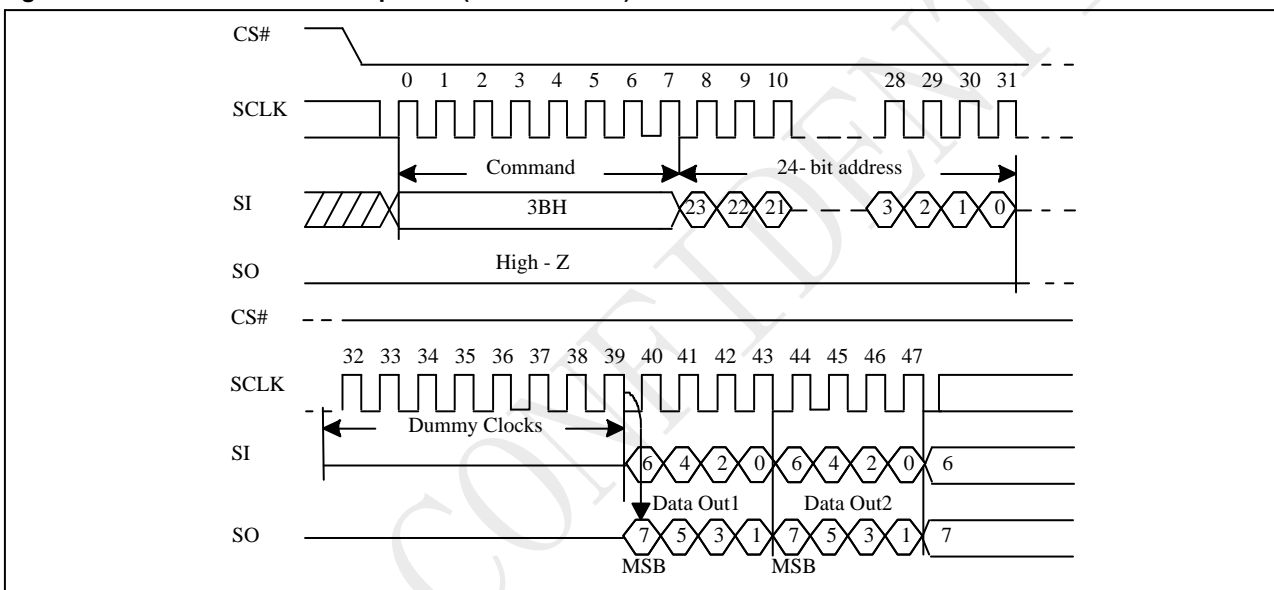

Note: 32-bit address is required when the device is operation in 4-byte address mode.

10.19 Dual Read with 4-Byte Address (DREAD4B 3CH)

The Dual Read with 4-Byte Address instruction is similar to the Dual Read instruction except that it requires 32-bit address instead of 24-bit address. No matter the device is operating in 3-Byte Address Mode or 4-byte Address Mode, the Dual Read with 4-Byte Address instruction will always require 32-bit address to access the entire 512Mb memory.

The Dual Read with 4-Byte Address (3Ch) instruction is only supported in Standard SPI mode.

Figure 10-19 Dual Read with 4-Byte Address Mode Sequence (Command 3C)

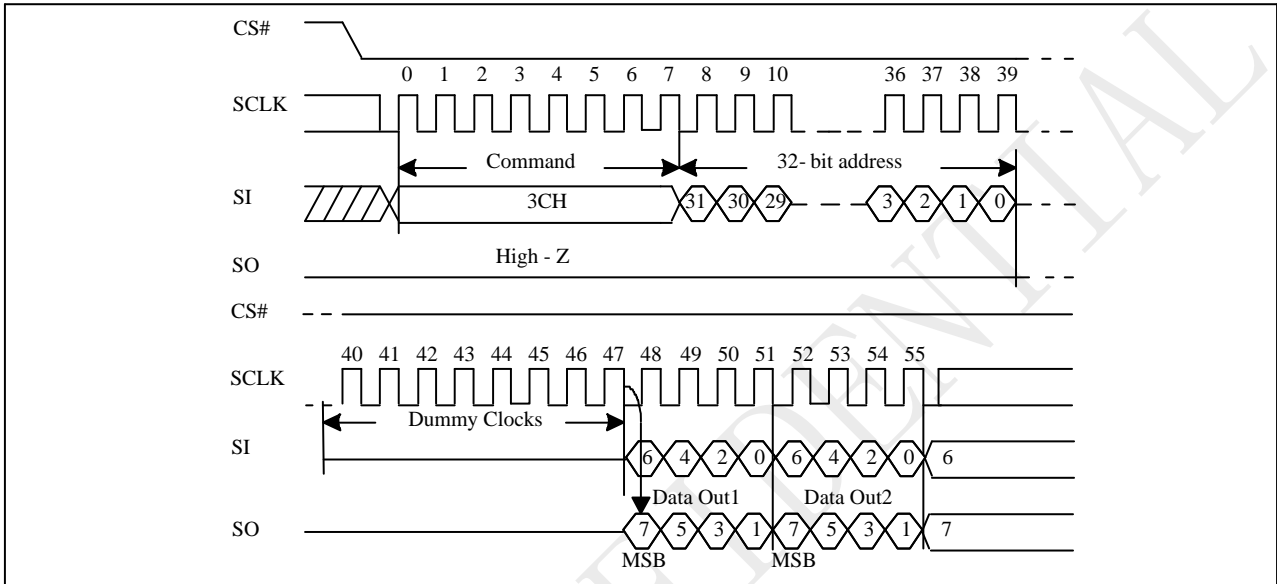

10.20 2IO Read (2READ BBH)

The 2READ instruction enables Double Transfer Rate of Serial NOR Flash in read mode. The address is latched on rising edge of SCLK, and data of every two bits (interleave on 2 I/O pins) shift out on the falling edge of SCLK at a maximum frequency f_T . The first address byte can be at any location. The address is automatically increased to the next higher address after each byte data is shifted out, so the whole memory can be read out at a single 2READ instruction. The address counter rolls over to 0 when the highest address has been reached.

Once writing 2READ instruction, the following address/dummy/data out will perform as 2-bit instead of previous 1-bit.

The sequence of issuing 2READ instruction is: CS# goes low → sending 2READ instruction → 24/32-bit address interleave on SIO1 & SIO0 → 8-bit dummy cycle on SIO1 & SIO0 → data out interleave on SIO1 & SIO0 → to end 2READ operation can use CS# to high at any time during data out.

While Program/Erase/Write Status Register cycle is in progress, 2READ instruction is rejected without any impact on the Program/Erase/Write Status Register current cycle.

Figure 10-20 2IO Read Sequence (Command BBH M5-4 ≠ (1,0))

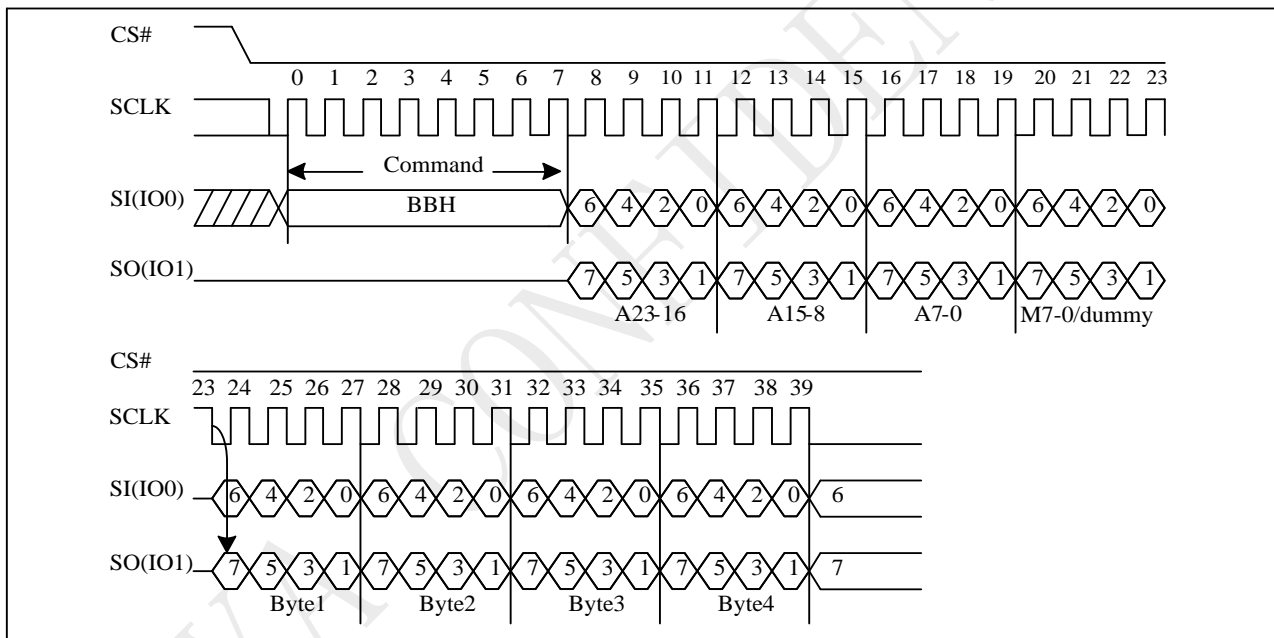

Note:

1. 32-bit address is required when the device is operation in 4-byte address mode.
2. M[5-4] = (1,0) is inhibited.
3. DC bit can set the number of dummy clocks.

2IO Continuous Read

“BBh” command supports 2IO Continuous Read which can further reduce command overhead through setting the “Continuous Read Mode” bits (M7-0) after the input 3/4-byte address. If the “Continuous Read Mode” bits (M5-4) = (1, 0), then the next 2IO Read command (after CS# is raised and then lowered) does not require the BBH command code.

If the “Continuous Read Mode” bits (M5-4) do not equal (1, 0), the next command requires the first BBH command code, thus returning to normal operation. A “Continuous Read Mode” Reset command can be used to reset (M5-4) before issuing normal command.

Figure 10-20a 2IO Continue Read (M5-4 = (1,0))

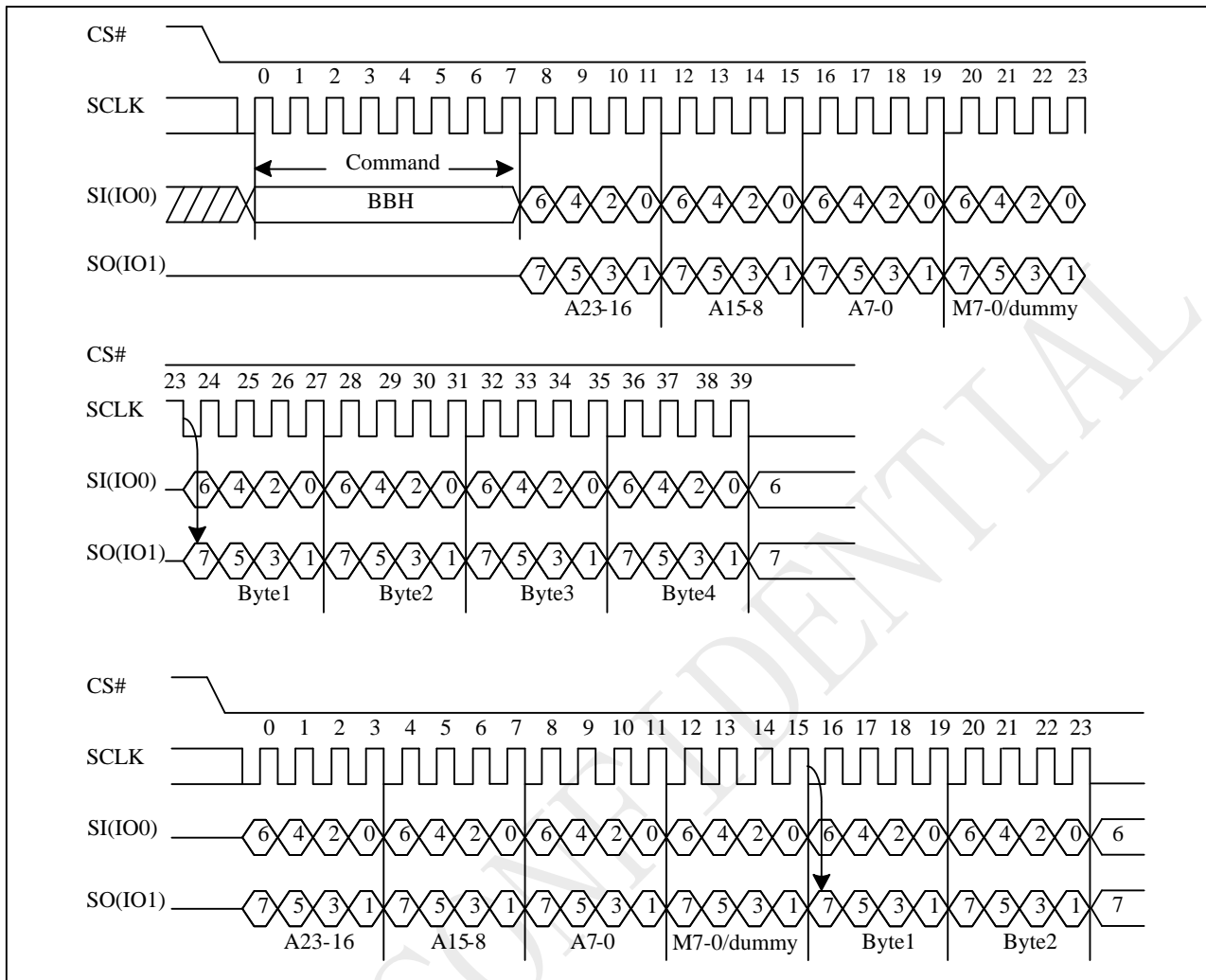

Note:

1. 32-bit address is required when the device is operation in 4-byte address mode.
2. 2IO Continue Read, if M5-4 = 1, 0. If not using Continue Read recommend to set M5-4 ≠ 1, 0.
3. DC bit can set the number of dummy clocks.

10.21 DTR 2IO Read (DTR_2READ BDH)

The DTR 2IO Read (BDh) instruction allows for improved random access while maintaining two IO pins, IO0 and IO1. It is similar to the DREAD (3Bh) instruction but with the capability to input the Address bits (A23/A31-0) two bits per clock. This reduced instruction overhead may allow for code execution (XIP) directly from the Dual SPI in some applications.

Figure 10-21 DTR 2IO Read Sequence (Command BDH M5-4 ≠ (1,0))

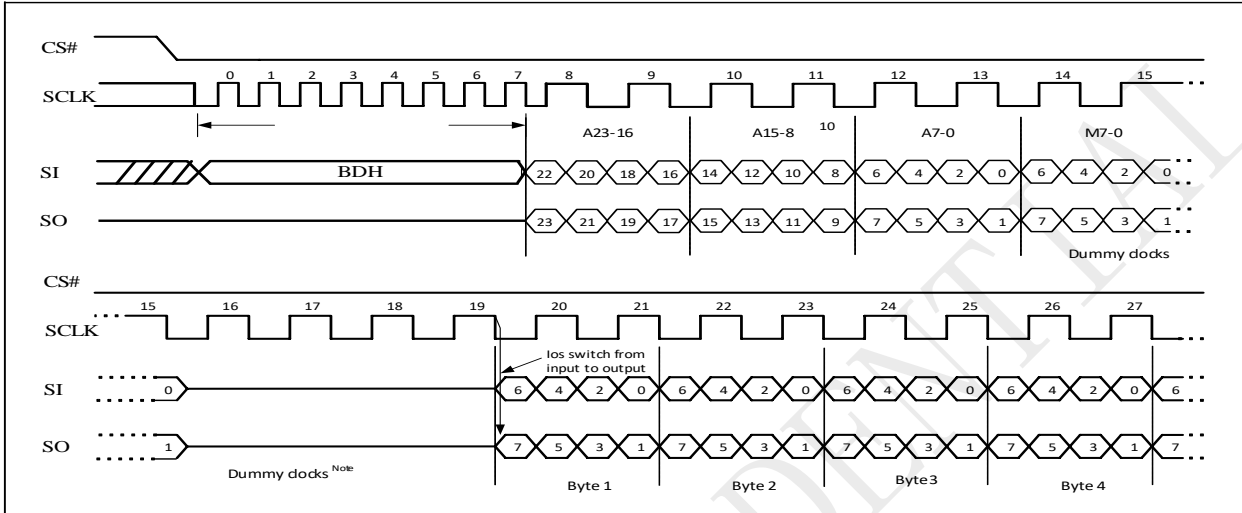

Note:

1. 32-bit address is required when the device is operation in 4-byte address mode.
2. DC bit can set the number of dummy clocks.

DTR 2IO Continuous Read

The BDh instruction supports Continuous Read Mode which can further reduce overhead through setting the "continuous Read Mode" bits(M7-0) after the input address (A23/A31-A0). If the "Continuous Read Mode" bits (M5-4) = (1, 0), then the next Read command (after CS# is raised and then lowered) does not require the BDH command code.

If the "Continuous Read Mode" bits (M5-4) do not equal (1, 0), the next command requires the first BDH command code, thus returning to normal operation. It is recommended to input FFFFh on IO0 for the next instruction (16 clocks), to ensure M4 = 1 and return the device to normal operation.

Figure 10-21a DTR 2IO Continuous Read Sequence (Command BDH M5-4 = (1,0))

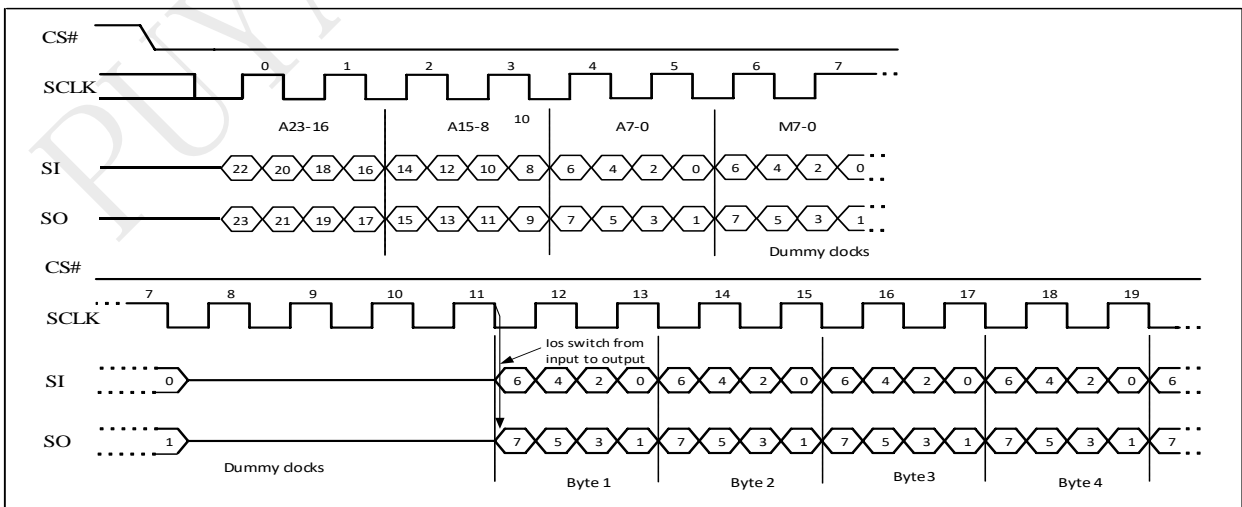

Note: 32-bit address is required when the device is operation in 4-byte address mode.

10.22 2IO Read with 4-Byte Address (2READ4B BCH)

The 2IO Read with 4-Byte Address instruction is similar to the 2IO Read instruction except that it requires 32-bit address instead of 24-bit address. No matter the device is operating in 3-Byte Address Mode or 4-byte Address Mode, the 2IORead with 4-Byte Address instruction will always require 32-bit address to access the entire 512Mb memory.

Figure 10-22 2IO Read with 4-Byte Address Sequence (Command BCH M5-4 ≠ (1,0))

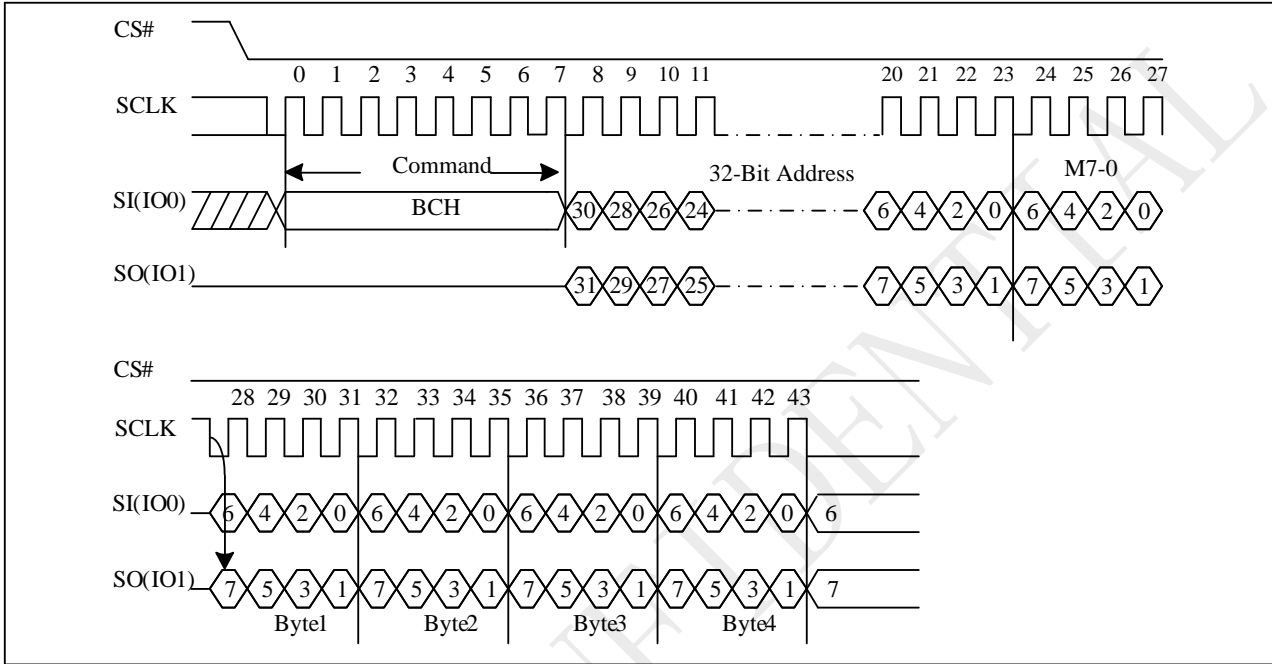

2IO Continuous Read with 4-Byte Address

If the “Continuous Read Mode” bits (M5-4) = (1, 0), then the next Read command (after CS# is raised and then lowered) does not require the BCH command code.

If the “Continuous Read Mode” bits (M5-4) do not equal (1, 0), the next command requires the first BCH command code, thus returning to normal operation. It is recommended to input FFFFh on IO0 for the next instruction (16 clocks), to ensure M4 = 1 and return the device to normal operation.

Figure 10-22a 2IO Continuous Read with 4-Byte Address Sequence (Command BCH M5-4 = (1,0))

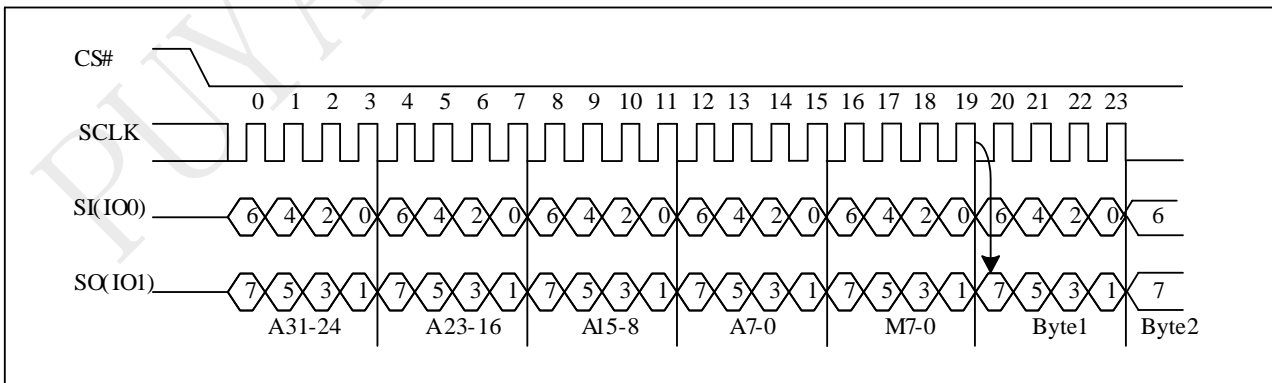

Note: 2IO Continue Read with 4-Byte Address, if M5-4 = 1, 0. If not using Continue Read recommend to set M5-4 ≠ 1, 0.

10.23 Quad Read (QREAD 6BH)

The QREAD instruction enable quad throughput of Serial NOR Flash in read mode. A Quad Enable (QE) bit of status Register must be set to "1" before sending the QREAD instruction. The address is latched on rising edge of SCLK, and data of every four bits (interleave on 4 I/O pins) shift out on the falling edge of SCLK at a maximum frequency fQ. The first address byte can be at any location. The address is automatically increased to the next higher address after each byte data is shifted out, so the whole memory can be read out at a single QREAD instruction. The address counter rolls over to 0 when the highest address has been reached. Once writing QREAD instruction, the following data out will perform as 4-bit instead of previous 1-bit.

The sequence of issuing QREAD instruction is: CS# goes low → sending QREAD instruction → 3/4-byte address on SI → 8-bit dummy cycle → data out interleave on SIO3, SIO2, SIO1 & SIO0 → to end QREAD operation can use CS# to high at any time during data out.

While Program/Erase/Write Status Register cycle is in progress, QREAD instruction is rejected without any impact on the Program/Erase/Write Status Register current cycle.

Figure 10-23 Quad Read Sequence (Command 6BH)

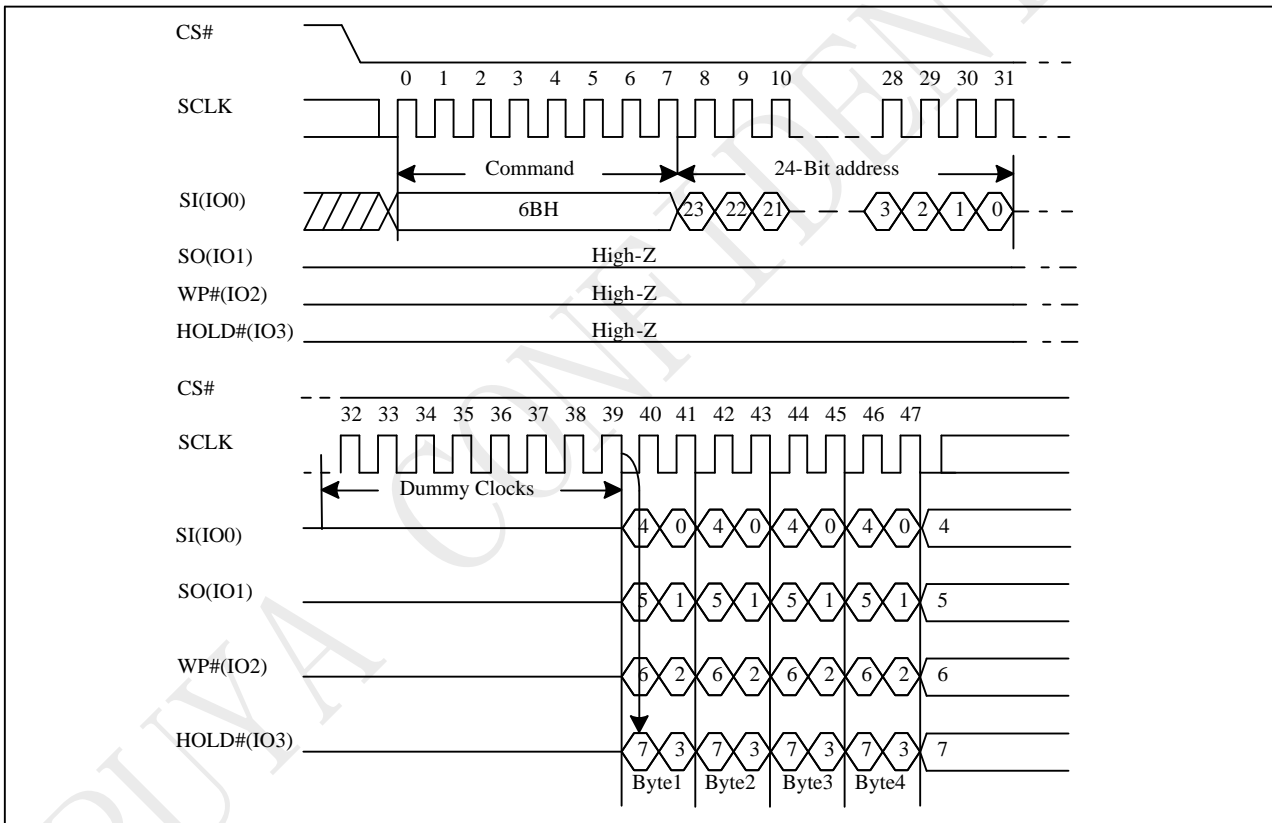

Note: 32-bit address is required when the device is operation in 4-byte address mode.

10.24 Quad Read with 4-Byte Address (QREAD4B 6CH)

The Quad Read with 4-Byte Address instruction is similar to the Quad Read instruction except that it requires 32-bit address instead of 24-bit address. No matter the device is operating in 3-Byte Address Mode or 4-byte Address Mode, the Quad Read with 4-Byte Address instruction will always require 32-bit address to access the entire 512Mb memory.

The Quad Read with 4-Byte Address (6Ch) instruction is only supported in Standard SPI mode.

Figure 10-24 Quad Read with 4-Byte Address Sequence (Command 6CH)

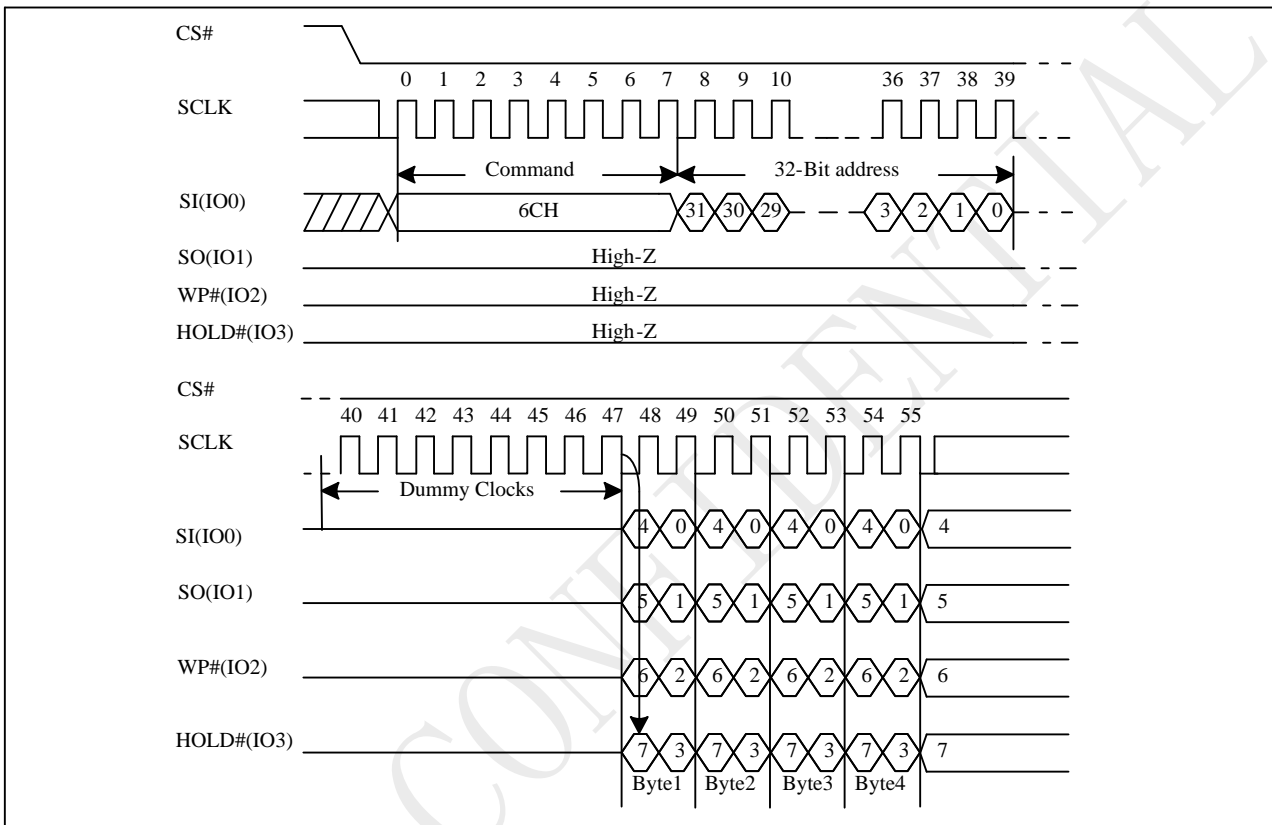

10.25 4IO Read (4READ EBH)

The 4READ instruction enable quad throughput of Serial NOR Flash in read mode. A Quad Enable (QE) bit of status Register must be set to "1" before sending the 4READ instruction. The address is latched on rising edge of SCLK, and data of every four bits (interleave on 4 I/O pins) shift out on the falling edge of SCLK at a maximum frequency fQ. The first address byte can be at any location. The address is automatically increased to the next higher address after each byte data is shifted out, so the whole memory can be read out at a single 4READ instruction. The address counter rolls over to 0 when the highest address has been reached. Once writing 4READ instruction, the following address/dummy/data out will perform as 4-bit instead of previous 1-bit.

The sequence of issuing 4READ instruction is: CS# goes low → sending 4READ instruction → 24/32-bit address interleave on SIO3, SIO2, SIO1 & SIO0 → 2+4 dummy cycles → data out interleave on SIO3, SIO2, SIO1 & SIO0 → to end 4READ operation can use CS# to high at any time during data out.

While Program/Erase/Write Status Register cycle is in progress, 4READ instruction is rejected without any impact on the Program/Erase/Write Status Register current cycle.

Figure 10-25 4IO Read Sequence (Command EBH M5-4 ≠ (1,0)) in SPI mode

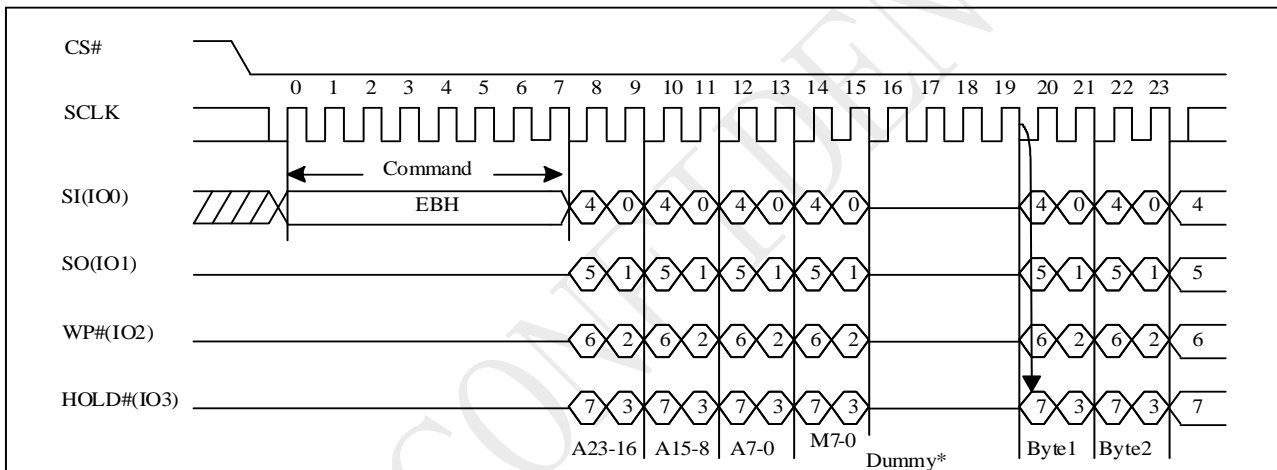

Note:

1. Hi-impedance is inhibited for the two clock cycles.
2. M[5-4] = (1,0) is inhibited.
3. 32-bit address is required when the device is operation in 4-byte address mode.
4. DC bit can set the number of dummy clocks.

4IO Read in QPI mode

The 4READ instruction is also supported in QPI mode. When QPI mode is enabled, the number of dummy clocks is configured by the "Set Read Parameters (C0h)" instruction to accommodate a wide range of applications with different needs for either maximum Fast Read frequency or minimum data access latency. Depending on the Read Parameter Bits P[5:4] setting, the number of dummy clocks can be configured as either 2, 4, 6 or 8. The default number of dummy clocks upon power up or after a Reset instruction is 2. In QPI mode, the "Continuous Read Mode" bits M7- 0 are also considered as dummy clocks. In the default setting, the data output will follow the Continuous Read Mode bits immediately.

"Continuous Read Mode" feature is also available in QPI mode for 4IO Read instruction. Please refer to the description on next pages.

"Wrap Around" feature is not available in QPI mode for 4IO Read instruction. To perform a read operation with fixed data length wrap around in QPI mode, a dedicated "Burst Read with Wrap" (0Ch) instruction must be used.

Figure 10-25a 4IO Read in QPI mode Sequence (QPI M5-4 ≠ (1,0))

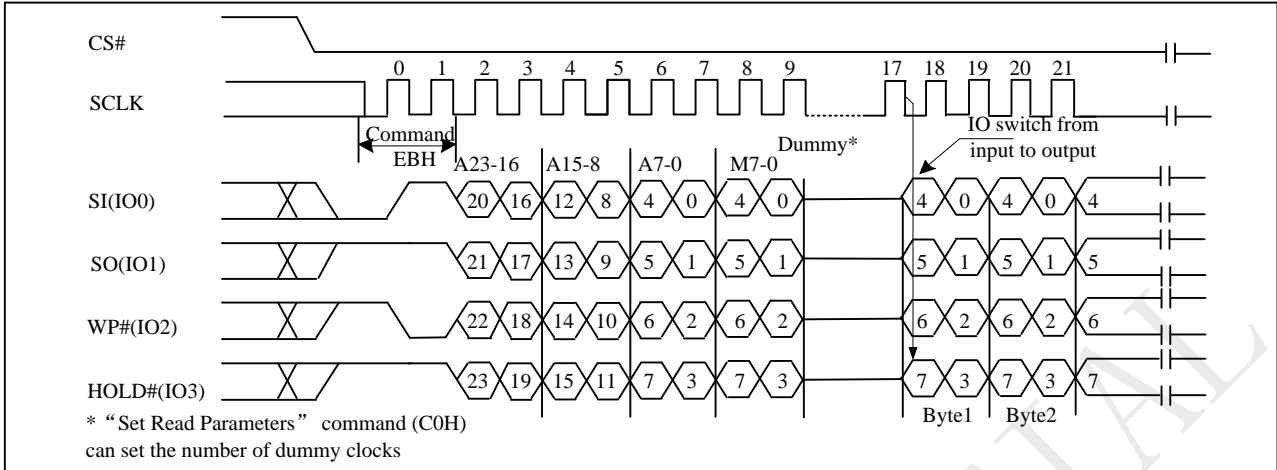

Note:

1. Hi-impedance is inhibited for the two clock cycles.
2. M[5-4] = (1,0) is inhibited.
3. 32-bit address is required when the device is operation in 4-byte address mode.
4. C0H command can set the number of dummy clocks.

4IO Read with "8/16/32/64-Byte Wrap Around" in Standard SPI mode

The 4IO Read instruction can also be used to access a specific portion within a page by issuing a "Set Burst with Wrap" (77h) command prior to EBh. The "Set Burst with Wrap" (77h) command can either enable or disable the "Wrap Around" feature for the following EBh commands. When "Wrap Around" is enabled, the data being accessed can be limited to either an 8, 16, 32 or 64-byte section of a 512-byte page. The output data starts at the initial address specified in the instruction, once it reaches the ending boundary of the 8/16/32/64-byte section, the output will wrap around to the beginning boundary automatically until CS# is pulled high to terminate the command.

The Burst with Wrap feature allows applications that use cache to quickly fetch a critical address and then fill the cache afterwards within a fixed length (8/16/32/64-byte) of data without issuing multiple read commands.

The "Set Burst with Wrap" instruction allows three "Wrap Bits", W6-4 to be set. The W4 bit is used to enable or disable the "Wrap Around" operation while W6-5 are used to specify the length of the wrap around section within a page.

4IO Continuous Read

"EBh" command supports 4IO Continuous Read which can further reduce command overhead through setting the "Continuous Read Mode" bits (M7-0) after the input 3/4-byte address (A23/31-A0). If the "Continuous Read Mode" bits (M5-4) = (1, 0), then the next 4IO Read command (after CS# is raised and then lowered) does not require the EBH command code.

If the "Continuous Read Mode" bits (M5-4) do not equal (1, 0), the next command requires the first EBH command code, thus returning to normal operation. A "Continuous Read Mode" Reset command can be used to reset (M5-4) before issuing normal command.

Figure 10-25b 4IO Continuous Read Sequence (M5-4 = (1,0))

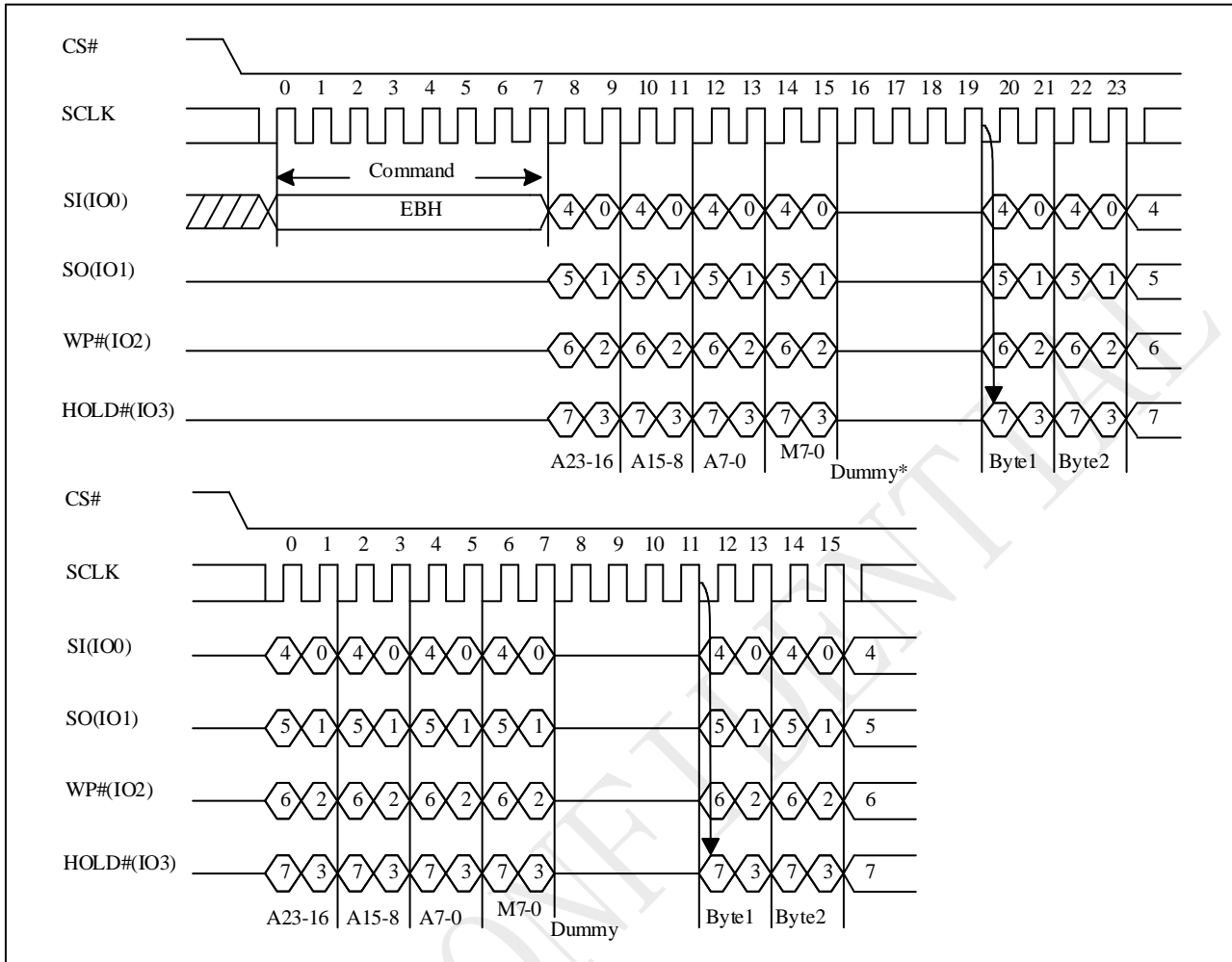

Note:

1. 4IO Continuous Read Mode, if M5-4 = 1, 0. If not using Continuous Read recommend to set M5-4 ≠ 1, 0.
2. 32-bit address is required when the device is operation in 4-byte address mode.
3. DC bit can set the number of dummy clocks.

10.26 4IO Read with 4-Byte Address (4READ4B ECH)

The 4IO Read with 4-Byte Address (ECH) instruction is similar to the 4IO Read (EBh) instruction except that it requires 32-bit address instead of 24-bit address. No matter the device is operating in 3-Byte Address Mode or 4-byte Address Mode, the 4IO Read with 4-Byte Address instruction will always require 32-bit address to access the entire 512Mb memory.

The 4IO Read with 4-Byte Address (ECH) instruction is only supported in Standard SPI mode.

Figure 10-26 4IO Read with 4-Byte Address Sequence (Command ECH M5-4 ≠ (1,0))

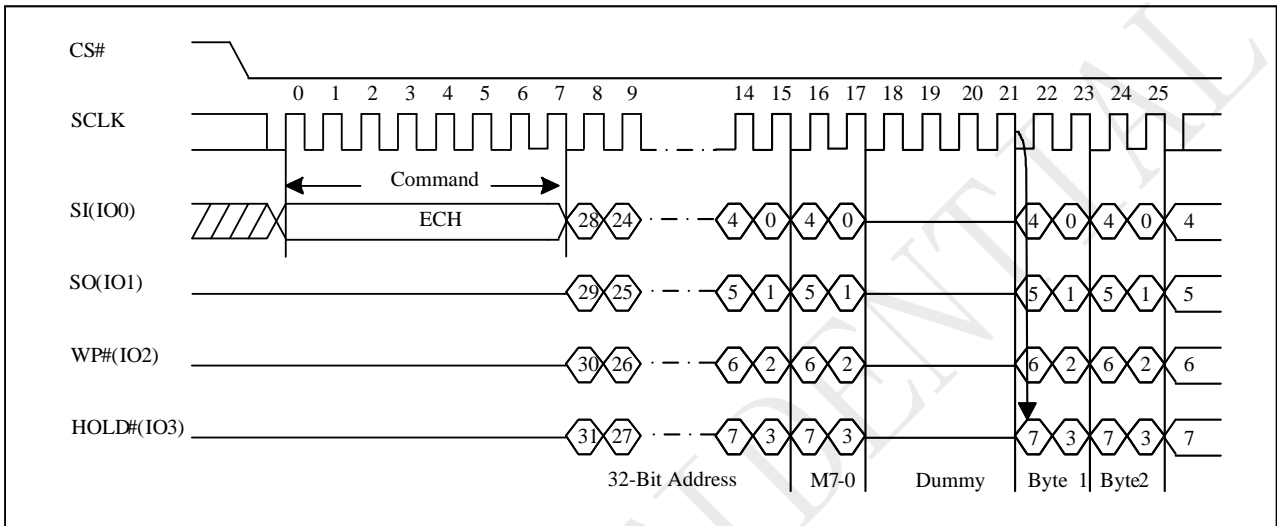

Note:

1. Hi-impedance is inhibited for the mode clock cycles.
2. M[5-4] = (1,0) is inhibited.
3. DC bit can set the number of dummy clocks.

Figure 10-26a 4IO Continuous Read with 4-Byte Address Sequence (Command ECH M5-4 = (1,0))

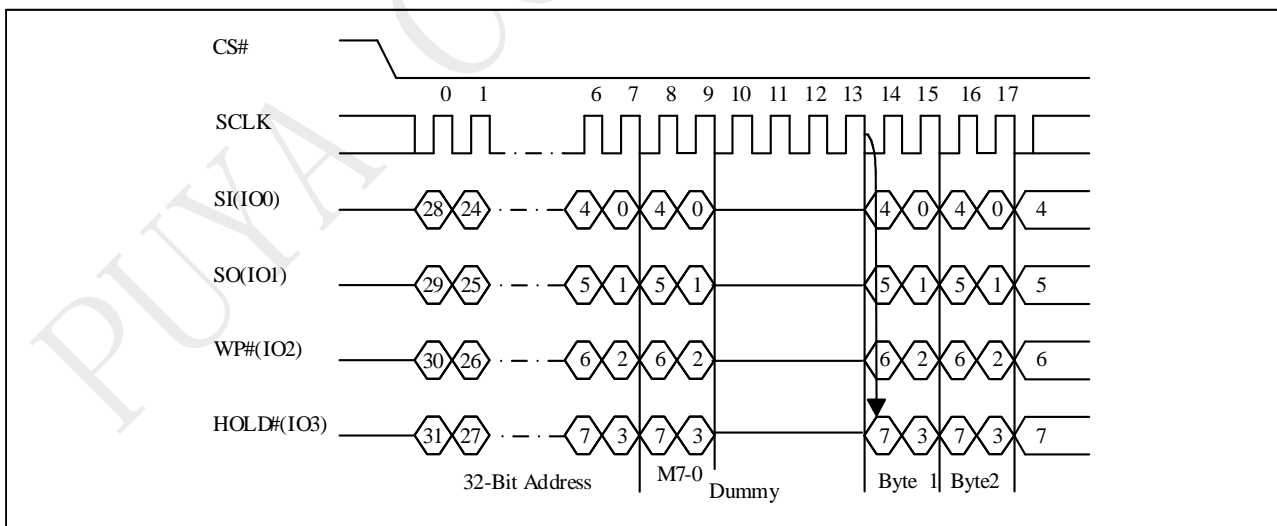

Note:

1. Hi-impedance is inhibited for the mode clock cycles.
2. 4IO Continue Read with 4-Byte Address, if M5-4 = 1, 0. If not using Continue Read recommend to set M5-4 ≠ 1, 0.
3. DC bit can set the number of dummy clocks.

10.27 DTR 4IO Read (DTR_4READ EDH)

The DTR 4IO Read (EDh) instruction is similar to the DTR 2IO Read (BDh) instruction except that address and data bits are input and output through four pins IO0, IO1, IO2 and IO3 and four Dummy clocks are required in SPI mode prior to the data output. The Quad I/O dramatically reduces instruction overhead allowing faster random access for code execution (XIP) directly from the Quad SPI. The Quad Enable bit (QE) of Status Register-2 must be set to enable the DTR 4IO Read Instruction.

Figure 10-27 DTR 4IO Read Mode Sequence (Command EDH M5-4 ≠ (1,0))

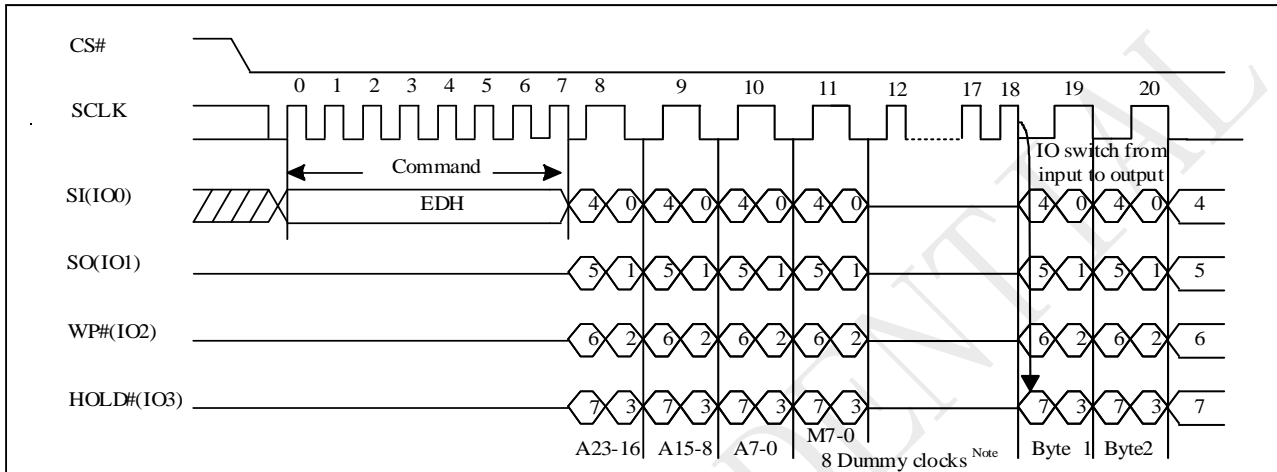

Note:

1. Hi-impedance is inhibited for the mode clock cycles.
2. M[5-4] = (1,0) is inhibited.
3. 32-bit address is required when the device is operation in 4-byte address mode.
4. DC bit can set the number of dummy clocks.

DTR 4IO Read with “8/16/32/64-Byte Wrap Around” in Standard SPI mode

The DTR 4IO Read instruction can also be used to access a specific portion within a page by issuing a “Set Burst Read” (77h) command prior to EDh. The “Set Burst Read” (77h) command can either enable or disable the “Wrap Around” feature for the following EDh commands. When “Wrap Around” is enabled, the data being accessed can be limited to either an 8, 16, 32 or 64-byte section of a 256-byte page. The output data starts at the initial address specified in the instruction, once it reaches the ending boundary of the 8/16/32/64-byte section, the output will wrap around to the beginning boundary automatically until CS# is pulled high to terminate the command.

The Burst with Wrap feature allows applications that use cache to quickly fetch a critical address and then fill the cache afterwards within a fixed length (8/16/32/64-byte) of data without issuing multiple read commands.

The “Set Burst Read” instruction allows three “Wrap Bits”, W6-4 to be set. The W4 bit is used to enable or disable the “Wrap Around” operation while W6-5 are used to specify the length of the wrap around section within a page.

DTR 4IO Continuous Read

The DTR 4IO Read instruction can further reduce instruction overhead through setting the “Continuous Read Mode” bits (M7-0) after the input Address bits (A23/A31-0). The upper nibble of the (M7-4) controls the length of the next DTR 4IO Read instruction through the inclusion or exclusion of the first byte instruction code. The lower nibble bits of the (M3-0) are don’t care (“x”). However, the IO pins should be high-impedance prior to the falling edge of the first data out clock.

If the “Continuous Read Mode” bits M5-4 = (1,0), then the next DTR 4IO Read instruction (after CS# is raised and then lowered) does not require the EDh instruction code. This reduces the instruction sequence by eight

clocks and allows the Read address to be immediately entered after CS# is asserted low. If the “Continuous Read Mode” bits M5-4 do not equal to (1,0), the next instruction (after CS# is raised and then lowered) requires the first byte instruction code, thus returning to normal operation. It is recommended to input FFh/3FFh on IO0 for the next instruction (8/10 clocks), to ensure M4 = 1 and return the device to normal operation.

Figure 10-27a DTR 4IO Continuous Read Mode Sequence (Command EDH M5-4 = (1,0))

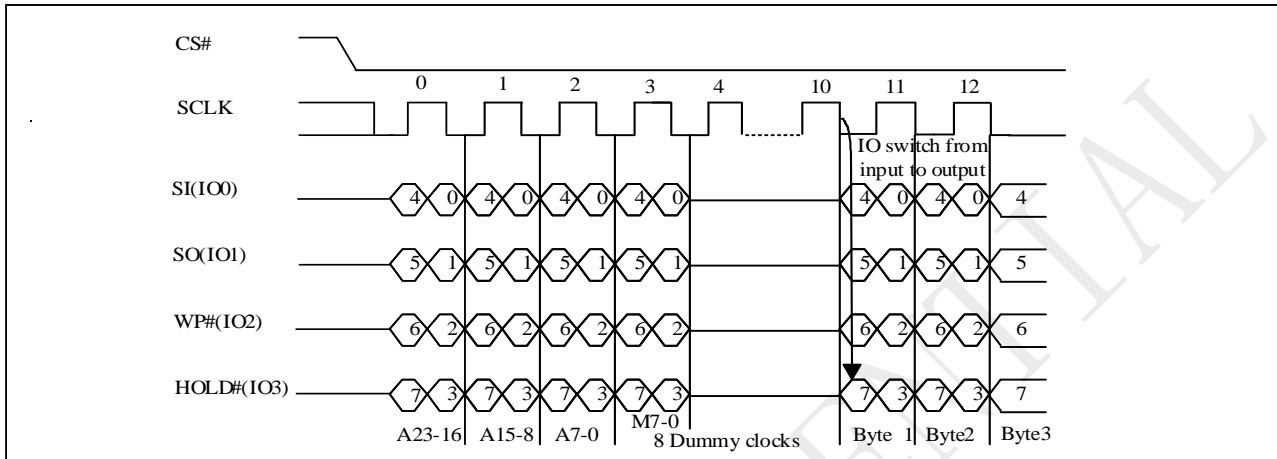

Note:

1. Hi-impedance is inhibited for the mode clock cycles.
2. DTR 4IO Continuous Read, if M5-4 = 1, 0. If not using Continuous Read recommend to set M5-4 ≠ 1, 0.
3. 32-bit address is required when the device is operation in 4-byte address mode.
4. DC bit can set the number of dummy clocks.

DTR 4IO Read (EDh) in QPI Mode

The DTR 4IO Read instruction is also supported in QPI mode. In QPI mode, the “Continuous Read Mode” bits M7-0 are also considered as dummy clocks. In the default setting, the data output will follow the Continuous Read Mode bits immediately.

“Continuous Read Mode” feature is also available in QPI mode for DTR 4IO Read instruction. “Wrap Around” feature is not available in QPI mode for DTR 4IO Read instruction. To perform a read operation with fixed data length wrap around in QPI mode, a dedicated “Burst Read with Wrap” (0Ch) instruction must be used.

Figure 10-27b DTR 4IO Read Mode Sequence (QPI EDH M5-4 ≠ (1,0))

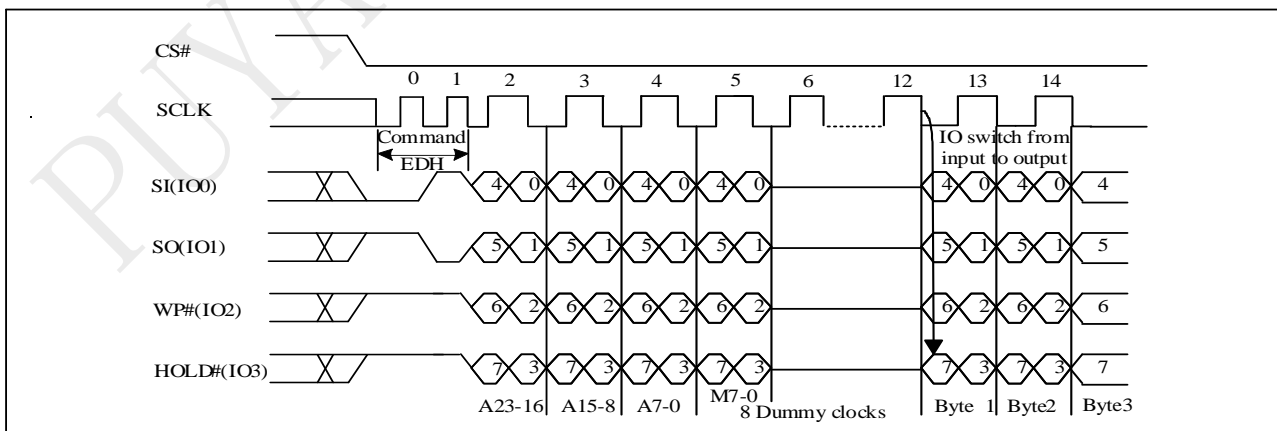

- Note:
1. Hi-impedance is inhibited for the two clock cycles.
 2. M[5-4] = (1,0) is inhibited.
 3. 32-bit address is required when the device is operation in 4-byte address mode.
 4. C0H command can set the number of dummy clocks.

10.28 DTR 4IO Read with 4-Byte Address (DTR_4READ4B EEH)

The DTR 4IO Read with 4-Byte Address (EEh) instruction is similar to the DTR 4IO Read (EDh) instruction except that it requires 32-bit address instead of 24-bit address. No matter the device is operating in 3-Byte Address Mode or 4-byte Address Mode, the DTR 4IO Read with 4-Byte Address instruction will always require 32-bit address to access the entire 512Mb memory.

The DTR 4IO Read with 4-Byte Address (EEh) instruction is only supported in Standard SPI mode.

Figure 10-28 DTR 4IO Read with 4-Byte Address Sequence (Command EEH M5-4 ≠ (1,0))

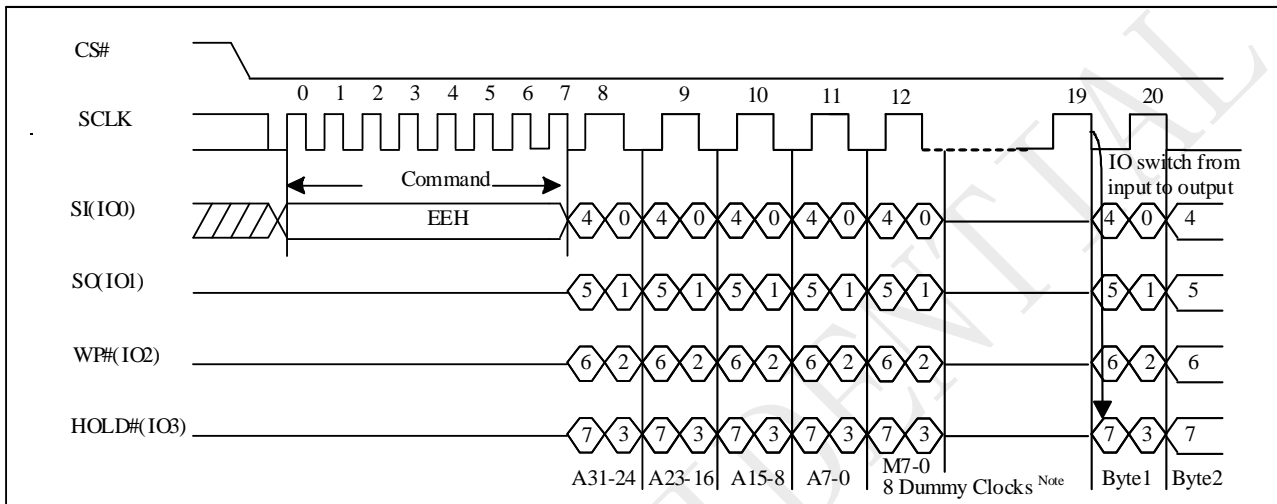

Note: DC bit can set the number of dummy clocks.

Figure 10-28a DTR 4IO Read with 4-Byte Address Sequence (QPI EEH M5-4 ≠ (1,0))

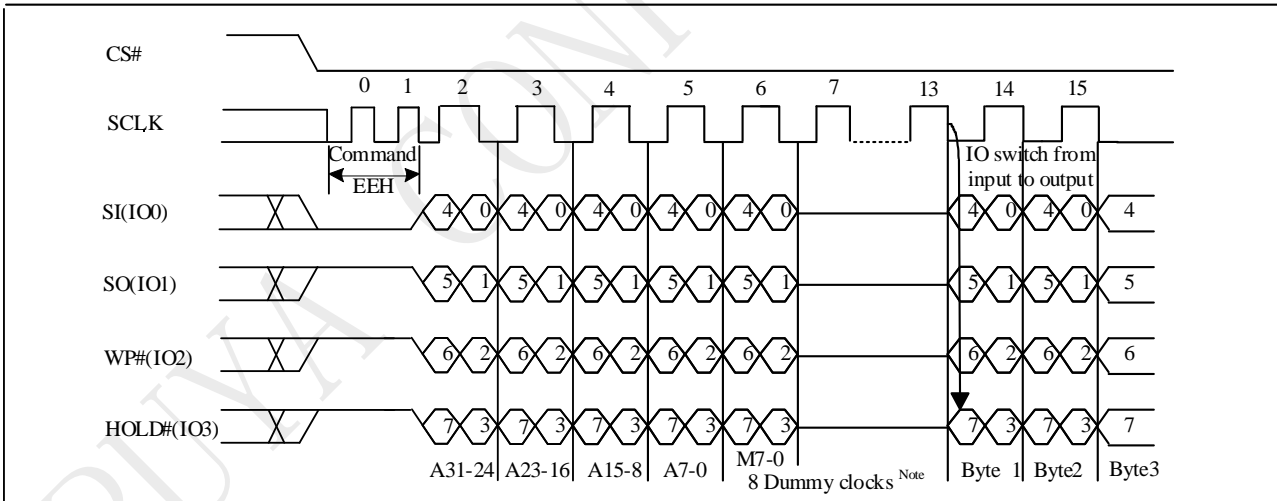

Note:

1. Hi-impedance is inhibited for the mode clock cycles. 2. M[5-4] = (1,0) is inhibited.
2. DC bit can set the number of dummy clocks.

10.29 Set Burst Length (SBL 77H)

The Set Burst with Wrap command is used in conjunction with “4IO Read” and “4IO Word Read” command to access a fixed length of 8/16/32/64-byte section within a 256-byte page, in standard SPI mode.

The Set Burst with Wrap command sequence: CS# goes low → Send Set Burst with Wrap command → Send 24/32 dummy bits → Send 8 bits “Wrap bits” → CS# goes high.

W6,W5	W4=0		W4=1 (default)	
	Wrap Around	Wrap Length	Wrap Around	Wrap Length
0,0	Yes	8-byte	No	N/A
0,1	Yes	16-byte	No	N/A
1,0	Yes	32-byte	No	N/A
1,1	Yes	64-byte	No	N/A

If the W6-W4 bits are set by the Set Burst with Wrap command, all the following “4IO Read” command will use the W6-W4 setting to access the 8/16/32/64-byte section within any page. To exit the “Wrap Around” function and return to normal read operation, another Set Burst with Wrap command should be issued to set W4=1. The default value of W4 upon power on or after a software/hardware reset is 1.

Figure 10-29 Set Burst Read (SBL) Sequence (Command 77H)

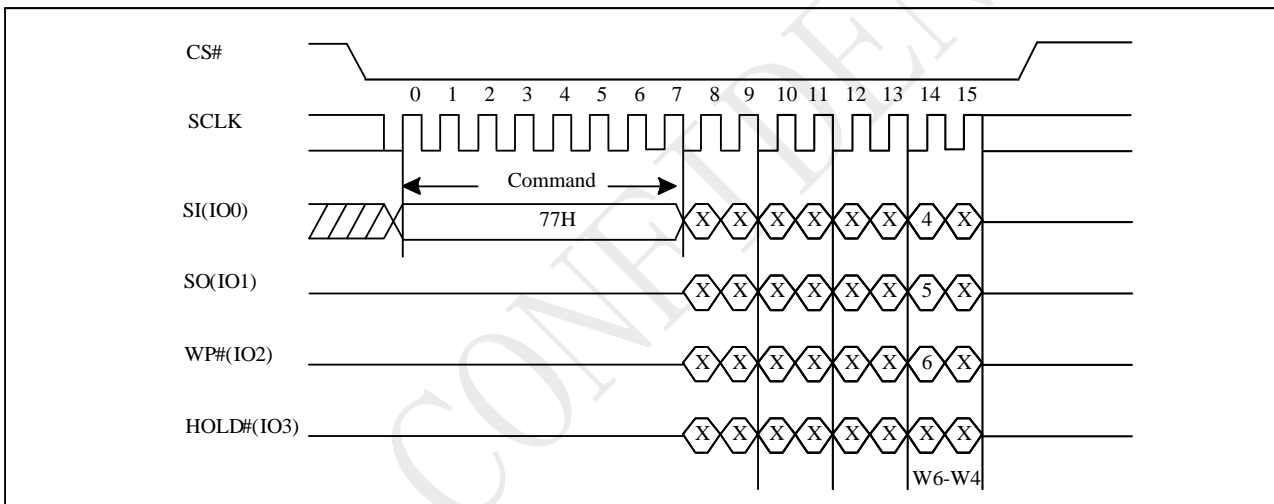

Note: 32-bit dummy bits are required when the device is operation in 4-byte address mode.

10.30 Set Read Parameters (C0h)

In QPI mode, to accommodate a wide range of applications with different needs for either maximum read frequency or minimum data access latency, “Set Read Parameters (C0h)” instruction can be used to configure the number of dummy clocks for “Fast Read (0Bh)”, “4IO Read (EBh)” & “Burst Read with Wrap (0Ch)” & “Read SFDP Mode (5Ah)” instructions, and to configure the number of bytes of “Wrap Length” for the “Burst Read with Wrap (0Ch)” instruction.

In Standard SPI mode, the “Set Read Parameters (C0h)” instruction is not accepted. The dummy clocks for various Fast Read instructions in Standard/Dual/Quad SPI mode are configured by DC bit. The “Wrap Length” is set by W5-4 bit in the “Set Burst with Wrap (77h)” instruction. This setting will remain unchanged when the device is switched from Standard SPI mode to QPI mode.

The default “Wrap Length” after a power up or a Reset instruction is 8 bytes, the default number of dummy clocks is 2. The number of dummy clocks is only programmable for “Fast Read (0Bh)”, “4IO Read (EBh)” & “Burst Read with Wrap (0Ch)” instructions in the QPI mode. Whenever the device is switched from SPI mode to QPI mode, the number of dummy clocks should be set again, prior to any 0Bh, EBh or 0Ch instructions.

P5-P4	Dummy Clocks	P1-P0	Wrap Length
0,0	10	0,0	8-byte
0,1	4	0,1	16-byte
1,0	6	1,0	32-byte
1,1	8	1,1	64-byte

Figure 10-30 Set Read Parameters Sequence (QPI)

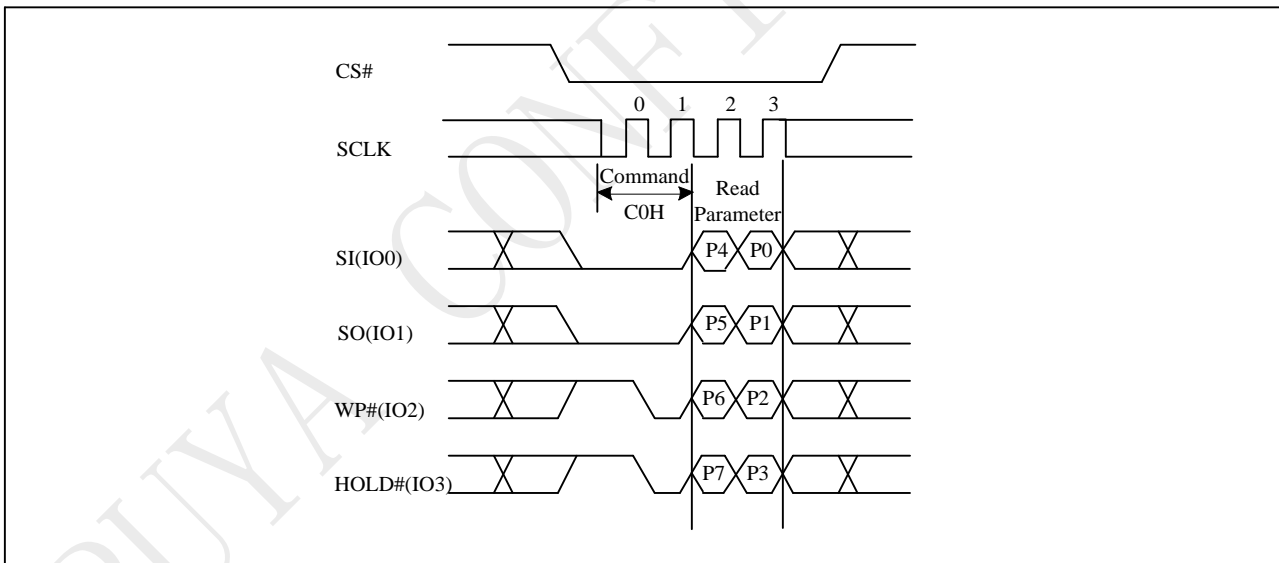

10.31 Burst Read with Wrap (0Ch)

The “Burst Read with Wrap (0Ch)” command provides an alternative way to perform the read operation with “Wrap Around” in QPI mode. This command is similar to the “Fast Read (0BH)” command in QPI mode, except the addressing of the read operation will “Wrap Around” to the beginning boundary of the “Wrap Around” once the ending boundary is reached. The “Wrap Length” and the number of dummy clocks can be configured by the “Set Read Parameters (C0H)” command.

Figure 10-31 Burst Read with Wrap Sequence (QPI)

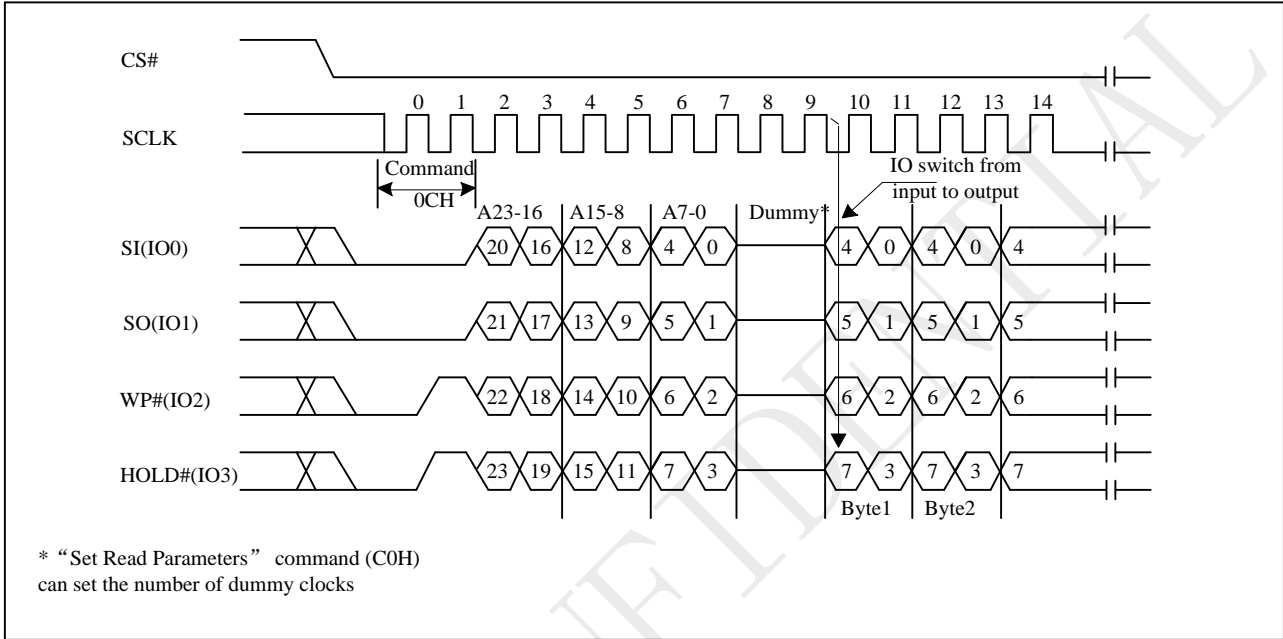

Note:

32-bit address is required when the device is operation in 4-byte address mode.

10.32 DTR Burst Read with Wrap (0Eh)

The “DTR Burst Read with Wrap (0EH)” command provides an alternative way to perform the read operation with “Wrap Around” in QPI mode. This command is similar to the “DTR Fast Read (0DH)” command in QPI mode, except the addressing of the read operation will “Wrap Around” to the beginning boundary of the “Wrap Around” once the ending boundary is reached. The “Wrap Length” and the number of dummy clocks can be configured by the “Set Read Parameters (C0H)” command.

Figure 10-32 Burst Read with Wrap Sequence (QPI)

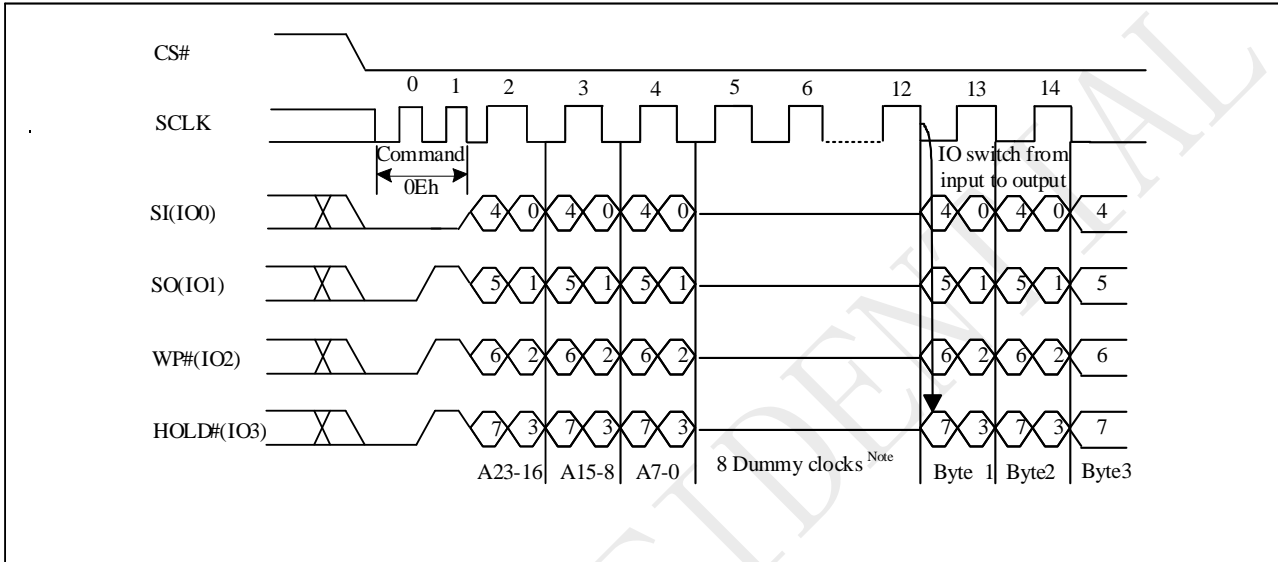

Note:

1. 32-bit address is required when the device is operation in 4-byte address mode.
2. DC bit can set the number of dummy clocks.

10.33 Data Learning Pattern

The data learning pattern supports system/memory controller determine valid window of data output more easily and improve data capture reliability while the flash memory is running in high frequency.

Data learning pattern can be enabled or disabled by setting the bit4 of Configure Register (DLP bit). Once the DLP bit is set, the data learning pattern is inputted into dummy cycles. Enabling data learning pattern bit (DLP bit) will not affect the function of continue read mode bit. In dummy cycles, continuous mode bit still operates with the same function. Data learning pattern will output after continuous mode bit.

The data learning pattern is a fixed 8-bit data pattern (00110100). For STR (single transfer rate) instructions, the complete 8 bits will start to output right after the continuous mode bit. While dummy cycle is not sufficient of 8 cycles, the rest of the DLP bits will be cut. For DTR (double transfer rate) instructions, the complete 8 bits will start to output during the last 4 dummy cycle.

Figure 10-33 Fast Read with DLP bits output Sequence

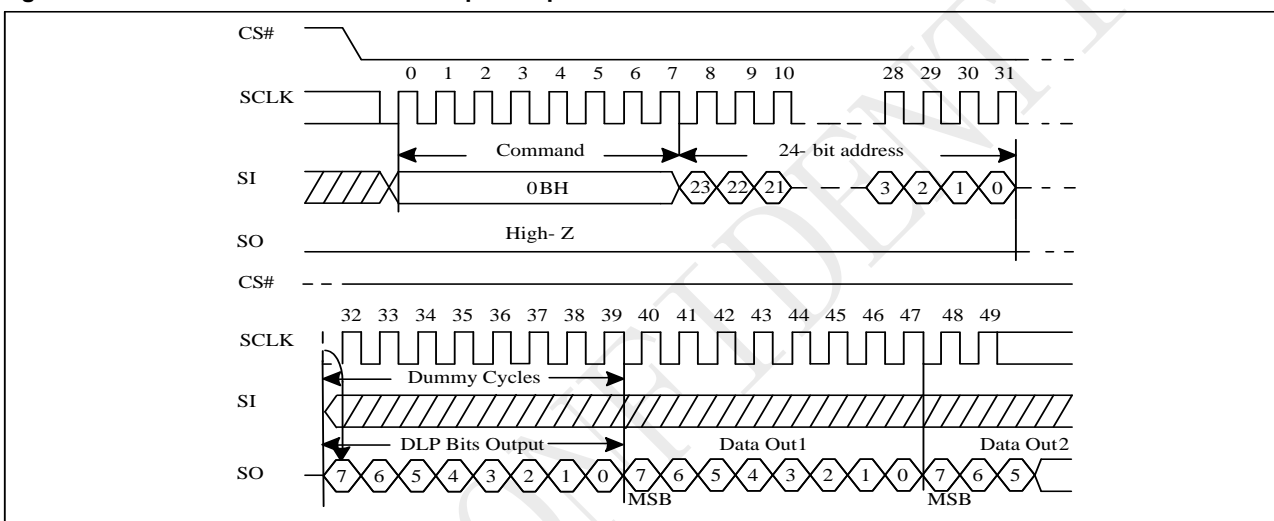

Note: The DLP bit is also valid for 4-byte 0BH and 0CH instruction

Figure 10-33a Dual Read with DLP bits output Sequence

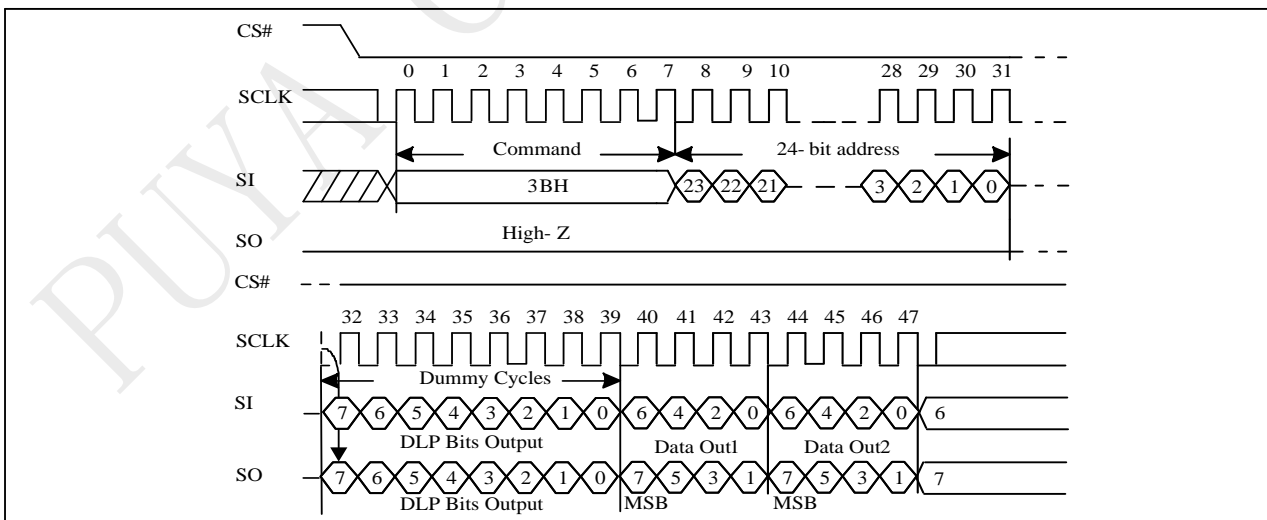

Note: The DLP bit is also valid for 4-byte 3BH and 3CH instruction

Figure 10-33b 4IOI Read with DLP bits output Sequence

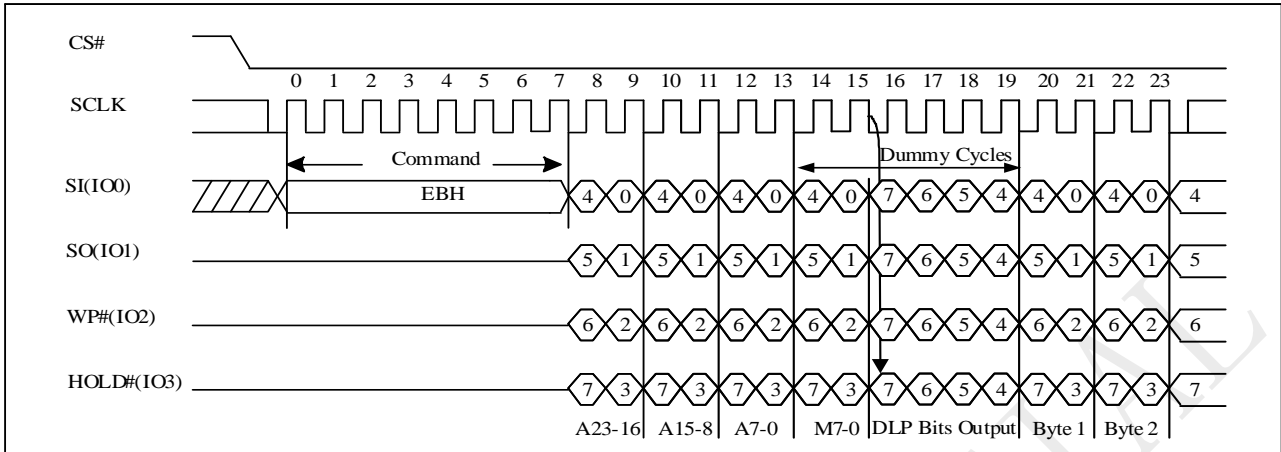

Note: The DLP bit is also valid for 4-byte EBH and ECH instruction

Figure 10-33c DTR 1IO Read with DLP bits output Sequence

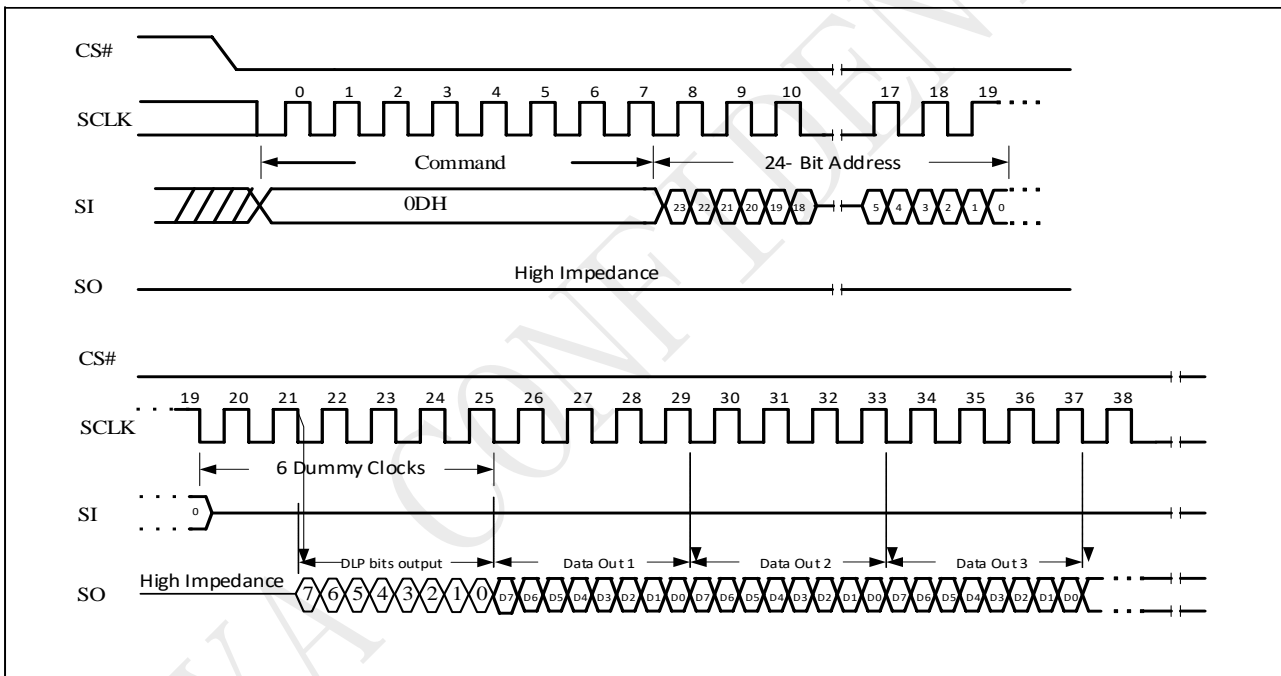

Note: The DLP bit is also valid for SPI 4-byte 0DH instruction

Figure 10-33d DTR 2IO Read with DLP bits output Sequence

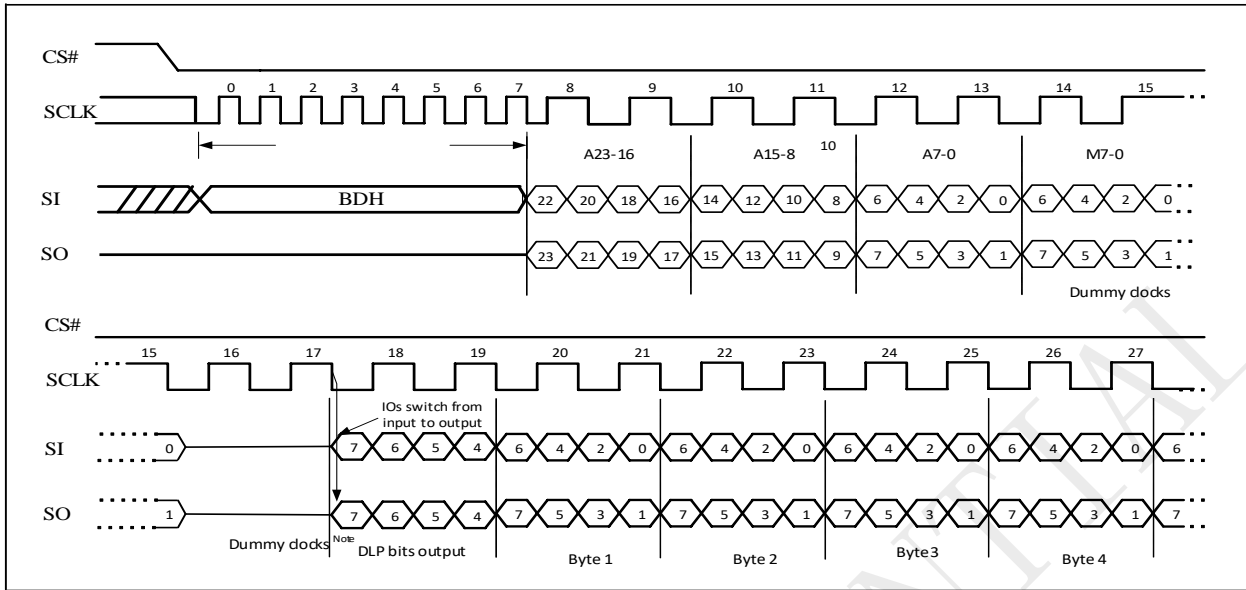

- Note:
1. The DLP bit is also valid for 4-byte BDH instruction
 2. DLP bits will sequentially output bit3~bit0 when DC=1.

Figure 10-33e DTR 4IO Read with DLP bits output Sequence

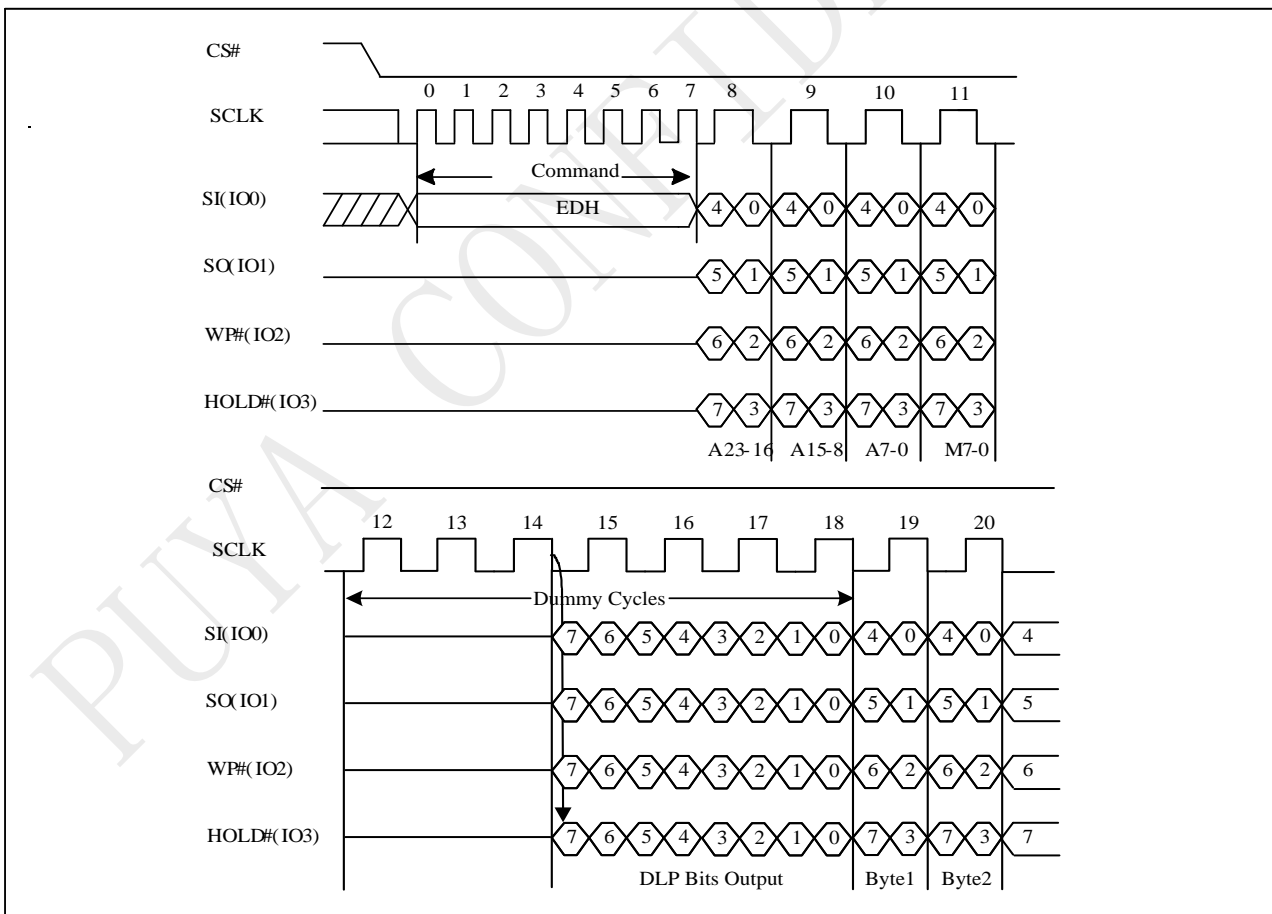

- Note:
1. The DLP bit is also valid for 4-byte EDH and EEH instruction and QPI 4IO DTR read instruction.
 2. DLP bits will delay 2 SCLK to output when DC=1.

10.34 Enable QPI (QPIEN 38H)

The device support both Standard/Dual/Quad SPI and QPI mode. The “Enable QPI (38H)” command can switch the device from SPI mode to QPI mode. In order to switch the device to QPI mode, the Quad Enable (QE) bit in Status Register-1 must be set to 1 first, and “Enable QPI (38H)” command must be issued. If the QE bit is 0, the “Enable QPI (38H)” command will be ignored and the device will remain in SPI mode. When the device is switched from SPI mode to QPI mode, the existing Write Enable Latch and Program/Erase Suspend status, and the Wrap Length setting will remain unchanged.

Figure 10-34 Enable QPI Sequence (38H)

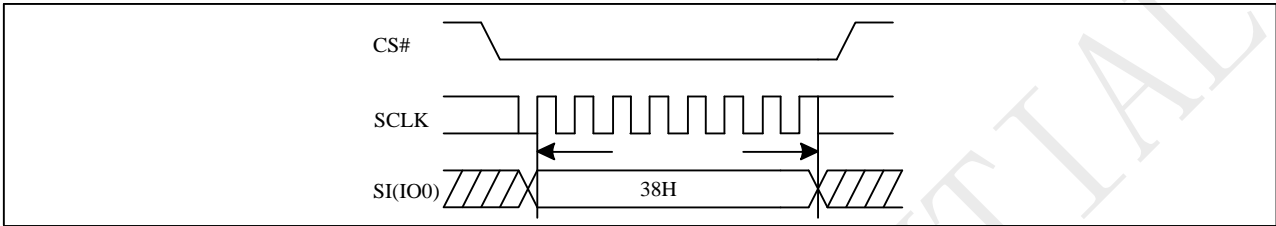

10.35 Disable QPI (FFH)

To exit the QPI mode and return to Standard/Dual/Quad SPI mode, the “Disable QPI (FFH)” command must be issued. When the device is switched from QPI mode to SPI mode, the existing Write Enable Latch and Program/Erase Suspend status, and the Wrap Length setting will remain unchanged.

Figure 10-35 Disable QPI Sequence (QPI)

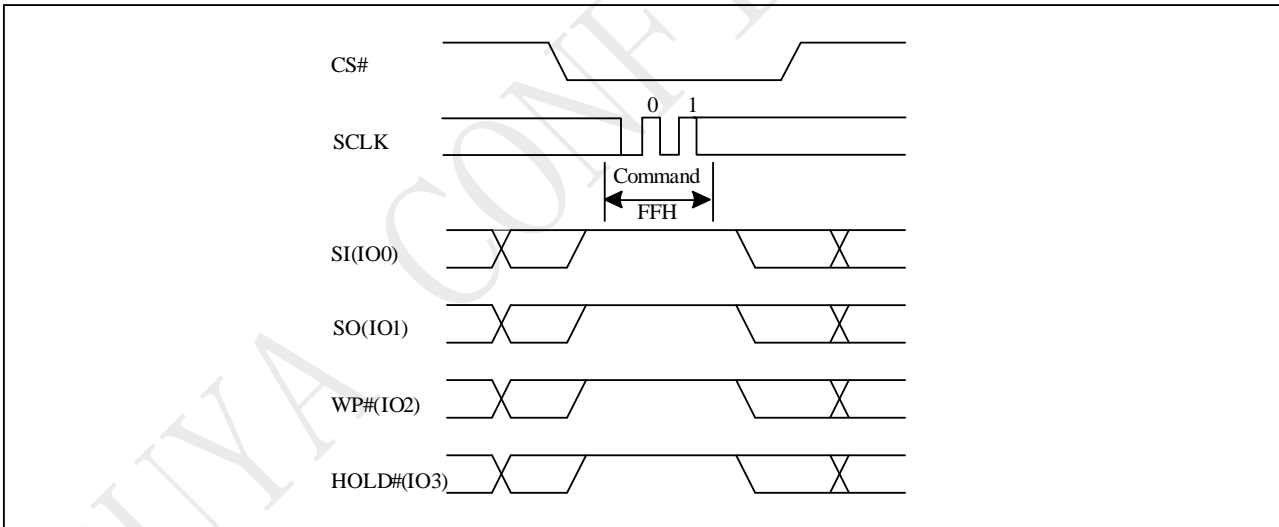

10.36 Sector Erase (SE 20H)

The Sector Erase (SE) instruction is for erasing the data of the chosen sector to be "1". A Write Enable (WREN) instruction must execute to set the Write Enable Latch (WEL) bit before sending the Sector Erase (SE). Any address of the sector is a valid address for Sector Erase (SE) instruction. The CS# must go high exactly at the byte boundary (the latest eighth of address byte been latched-in); otherwise, the instruction will be rejected and not executed. Address bits [Am-A12] (Am is the most significant address) select the sector address.

The sequence of issuing SE instruction is: CS# goes low → sending SE instruction code → 3/4-byte address on SI → CS# goes high.

The self-timed Sector Erase Cycle time (tSE) is initiated as soon as Chip Select (CS#) goes high. The Write in progress (WIP) bit still can be check out during the Sector Erase cycle is in progress. The WIP sets 1 during the tSE timing, and sets 0 when Sector Erase Cycle is completed, and the Write Enable Latch (WEL) bit is reset. If the sector is protected by BP4, BP3, BP2, BP1, BP0 bits, the Sector Erase (SE) instruction will not be executed on the sector.

Figure 10-36 Sector Erase (SE) Sequence (Command 20H)

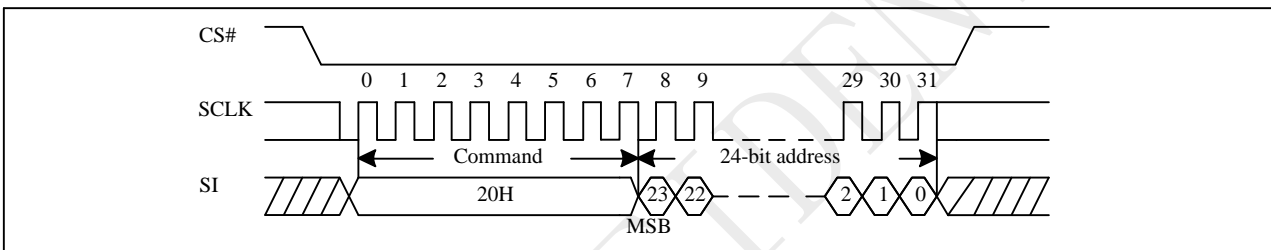

Note: 32-bit address is required when the device is operation in 4-byte address mode.

Figure 10-36a Sector Erase (SE) Sequence (QPI)

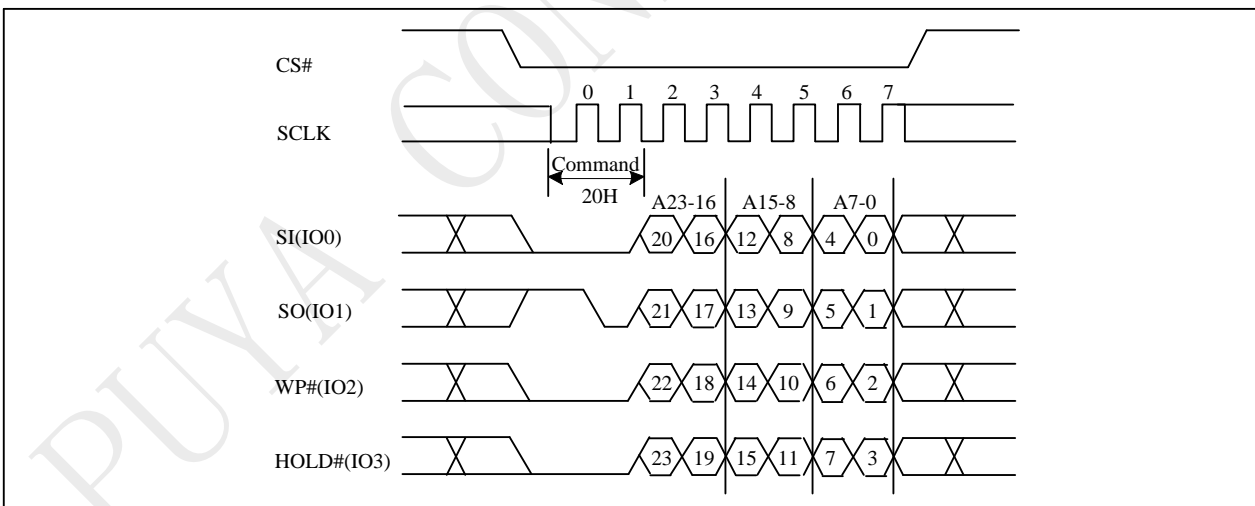

Note: 32-bit address is required when the device is operation in 4-byte address mode.

10.37 Sector Erase with 4-Byte Address (SE4B 21H)

The Sector Erase with 4-Byte Address instruction is similar to the Sector Erase instruction except that it requires 32-bit address instead of 24-bit address. No matter the device is operating in 3-Byte Address Mode or 4-byte Address Mode, the Sector Erase with 4-Byte Address instruction will always require 32-bit address to access the entire 512Mb memory.

Figure 10-37 Sector Erase with 4-Byte Address Sequence (Command 21H)

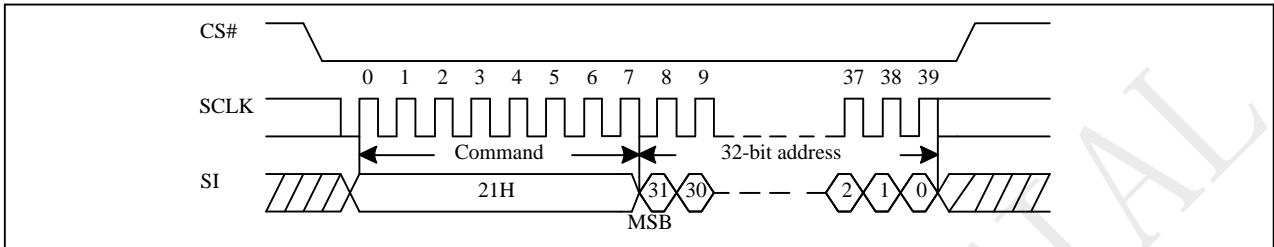

10.38 32K Block Erase (BE32K 52H)

The 32K Block Erase (BE32K) instruction is for erasing the data of the chosen block to be "1". The instruction is used for 32K-byte block erase operation. A Write Enable (WREN) instruction must be executed to set the Write Enable Latch (WEL) bit before sending the Block Erase (BE32K). Any address of the block is a valid address for Block Erase (BE32K) instruction. The CS# must go high exactly at the byte boundary (the least significant bit of address byte has been latched-in); otherwise, the instruction will be rejected and not executed.

The sequence of issuing BE32K instruction is: CS# goes low → sending BE32K instruction code → 3/4-byte address on SI → CS# goes high.

Figure 10-38 Block Erase 32K(BE32K) Sequence (Command 52H)

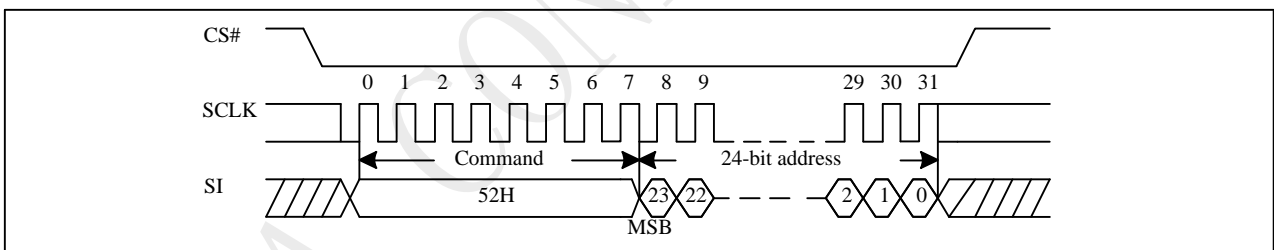

Note: 32-bit address is required when the device is operation in 4-byte address mode.

Figure 10-38a Block Erase 32K(BE32K) Sequence (QPI)

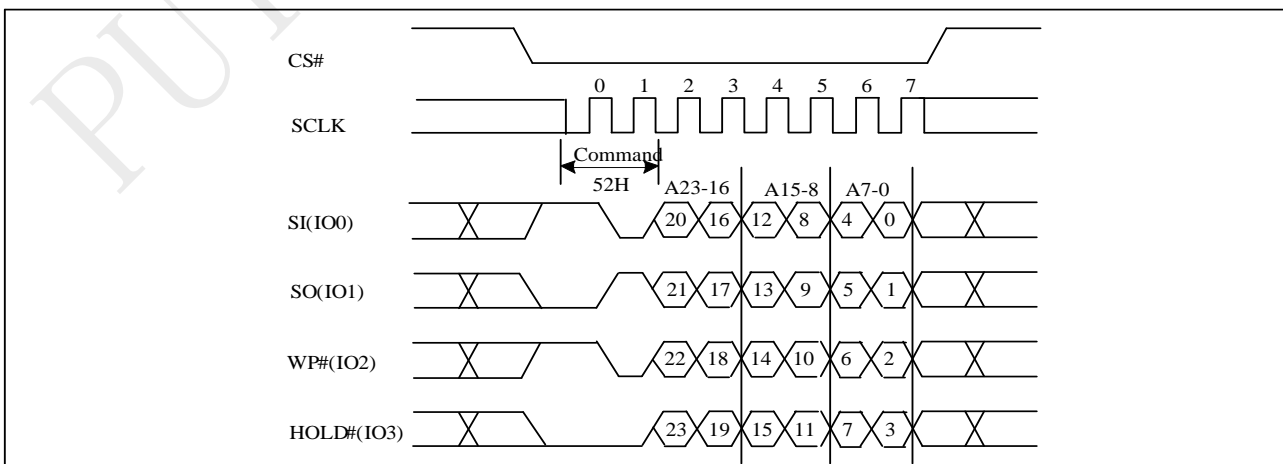

Note: 32-bit address is required when the device is operation in 4-byte address mode.

10.39 32K Block Erase with 4-Byte Address (BE32K4B 5CH)

The 32K Block Erase with 4-Byte Address instruction is similar to the 32K Block Erase instruction except that it requires 32-bit address instead of 24-bit address. No matter the device is operating in 3-Byte Address Mode or 4-byte Address Mode, the 32K Block Erase with 4-Byte Address instruction will always require 32-bit address to access the entire 512Mb memory.

Figure 10-39 Block Erase 32K with 4-Byte Address (BE32K4B) Sequence (Command 5CH)

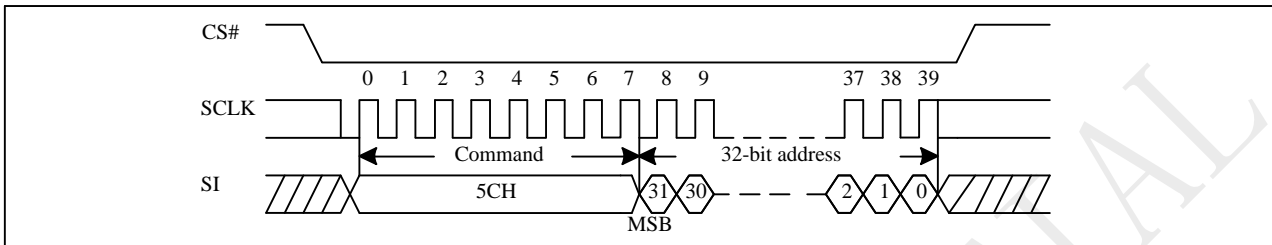

10.40 Block Erase (BE D8H)

The Block Erase (BE) instruction is for erasing the data of the chosen block to be "1". The instruction is used for 64K-byte block erase operation. A Write Enable (WREN) instruction must execute to set the Write Enable Latch (WEL) bit before sending the Block Erase (BE). Any address of the block is a valid address for Block Erase (BE) instruction. The CS# must go high exactly at the byte boundary (the latest eighth of address byte been latched-in); otherwise, the instruction will be rejected and not executed.

The sequence of issuing BE instruction is: CS# goes low → sending BE instruction code → 3/4-byte address on SI → CS# goes high.

The self-timed Block Erase Cycle time (tBE) is initiated as soon as Chip Select (CS#) goes high. The Write in Progress (WIP) bit still can be checked during the Block Erase cycle is in progress. The WIP sets 1 during the tBE timing, and sets 0 when Block Erase Cycle is completed, and the Write Enable Latch (WEL) bit is reset. If the block is protected by BP4, BP3, BP2, BP1, BP0 bits, the Block Erase (BE32K/BE) instruction will not be executed on the block.

Figure 10-40 Block Erase (BE) Sequence (Command D8H)

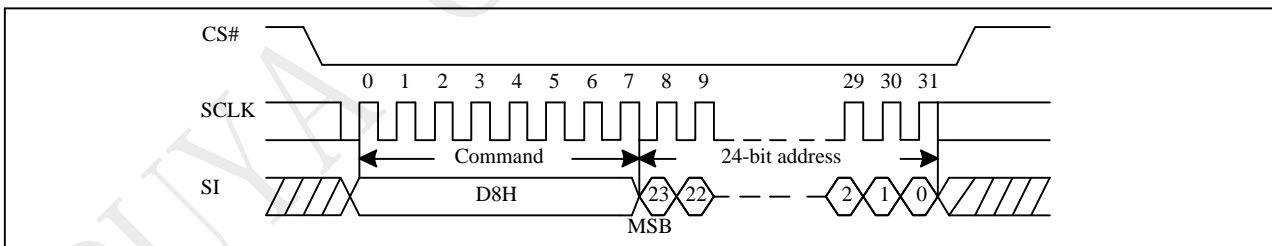

Note: 32-bit address is required when the device is operation in 4-byte address mode.

Figure 10-40a Block Erase (BE) Sequence (QPI)

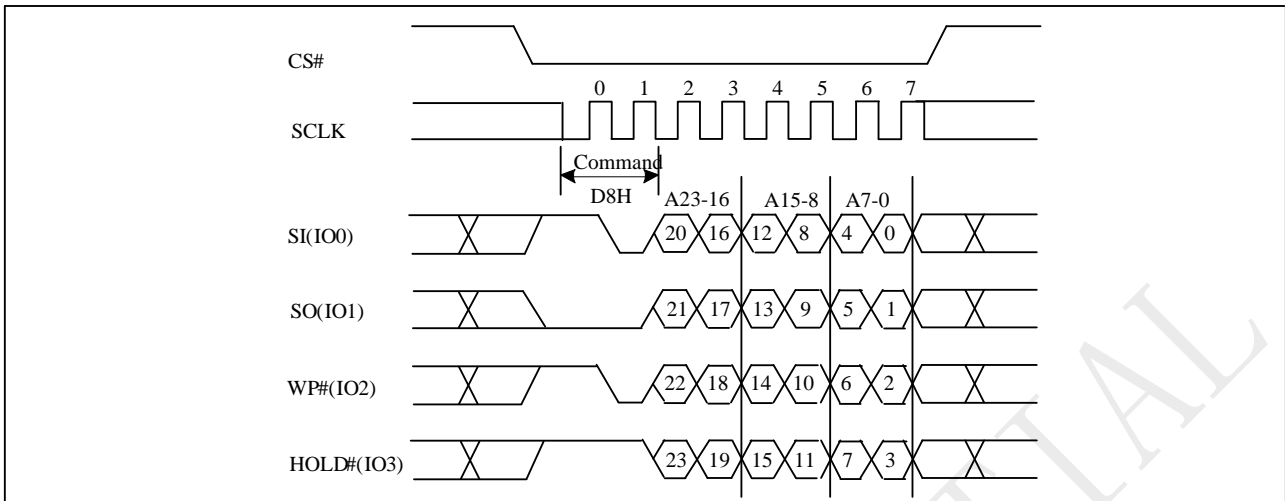

Note: 32-bit address is required when the device is operation in 4-byte address mode.

10.41 Block Erase with 4-Byte Address (BE4B DCH)

The Block Erase with 4-Byte Address instruction is similar to the Block Erase instruction except that it requires 32-bit address instead of 24-bit address. No matter the device is operating in 3-byte address mode or 4-byte address mode, the Block Erase with 4-Byte Address instruction will always require 32-bit address to access the entire 512Mb memory.

Figure 10-41 Block Erase with 4-Byte Address Sequence (Command DCH)

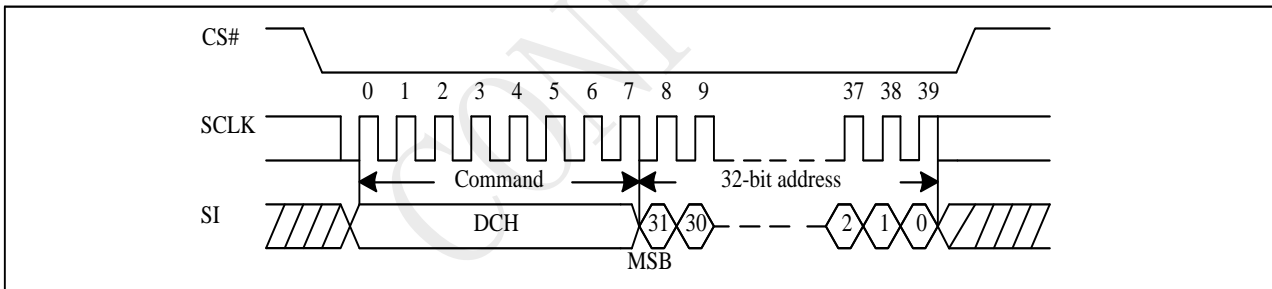

10.42 Chip Erase (CE 60H/C7H)

The Chip Erase (CE) instruction is for erasing the data of the whole chip to be "1". A Write Enable (WREN) instruction must execute to set the Write Enable Latch (WEL) bit before sending the Chip Erase (CE). The CS# must go high exactly at the byte boundary (the latest eighth of address byte been latched-in); otherwise, the instruction will be rejected and not executed.

The sequence of issuing CE instruction is: CS# goes low → sending CE instruction code → CS# goes high.

The self-timed Chip Erase Cycle time (tCE) is initiated as soon as Chip Select (CS#) goes high. The Write in Progress (WIP) bit still can be checked during the Chip Erase cycle is in progress. The WIP sets 1 during the tCE timing, and sets 0 when Chip Erase Cycle is completed, and the Write Enable Latch (WEL) bit is reset. If the chip is protected by BP4, BP3, BP2, BP1, BP0 bits, the Chip Erase (CE) instruction will not be executed.

It is noted that in Individual Protect Mode (WPS=1), the GBULK(98H) instruction must previously have been executed before each Chip Erase instruction.

Figure 10-42 Chip Erase (CE) Sequence (Command 60H or C7H)

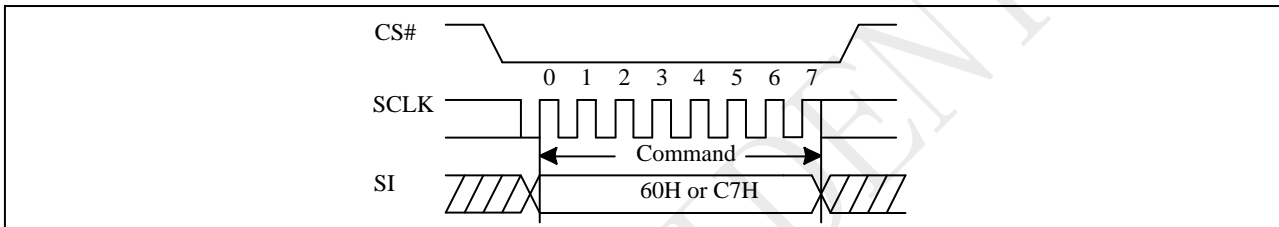
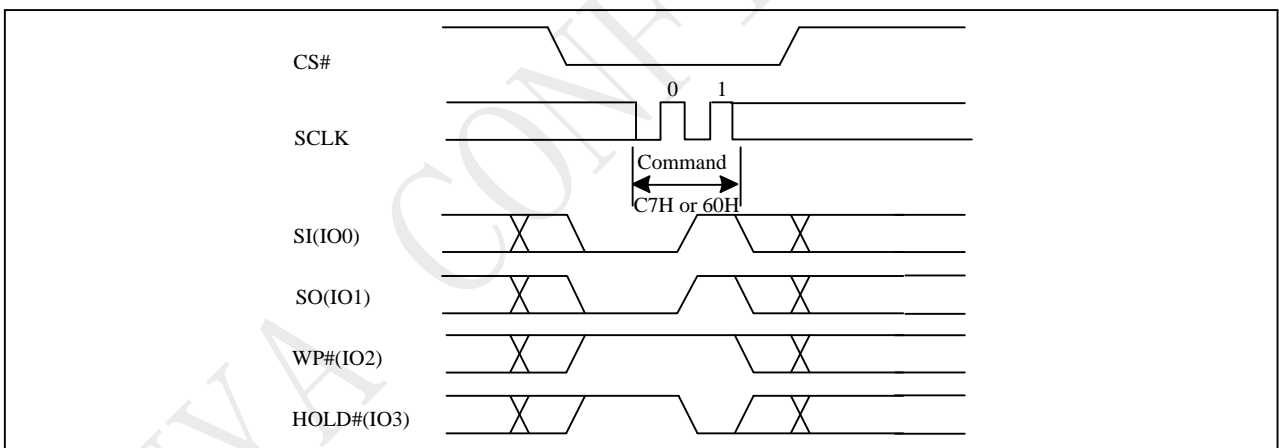

Figure 10-42a Chip Erase (CE) Sequence (QPI)



10.43 Page Program (PP 02H)

The Page Program (PP) instruction is for programming the memory to be "0". A Write Enable (WREN) instruction must execute to set the Write Enable Latch (WEL) bit before sending the Page Program (PP). The device programs only the last 256 data bytes sent to the device. If the entire 256 data bytes are going to be programmed, A7-A0 (The eight least significant address bits) should be set to 0. If the eight least significant address bits (A7-A0) are not all 0, all transmitted data going beyond the end of the current page are programmed from the start address of the same page (from the address A7-A0 are all 0). If more than 256 bytes are sent to the device, the data of the last 256-byte is programmed at the request page and previous data will be disregarded. If less than 256 bytes are sent to the device, the data is programmed at the requested address of the page.

For the very best performance, programming should be done in full pages of 256 bytes aligned on 256 byte boundaries with each Page being programmed only once. Using the Page Program (PP) command to load an

entire page, within the page boundary, will save overall programming time versus loading less than a page into the program buffer.

It is possible to program from one byte up to a page size in each Page programming operation. Please refer to the P25Q serial flash application note for multiple byte program operation within one page.

The sequence of issuing PP instruction is: CS# goes low → sending PP instruction code → 3/4-byte address on SI → at least 1-byte on data on SI → CS# goes high.

The CS# must be kept low during the whole Page Program cycle; The CS# must go high exactly at the byte boundary (the latest eighth bit of data being latched in), otherwise the instruction will be rejected and will not be executed.

The self-timed Page Program Cycle time (tPP) is initiated as soon as Chip Select (CS#) goes high. The Write in Progress (WIP) bit still can be checked during the Page Program cycle is in progress. The WIP sets 1 during the tPP timing, and sets 0 when Page Program Cycle is completed, and the Write Enable Latch (WEL) bit is reset. If the page is protected by BP4, BP3, BP2, BP1, BP0 bits, the Page Program (PP) instruction will not be executed.

Figure 10-43 Page Program (PP) Sequence (Command 02H)

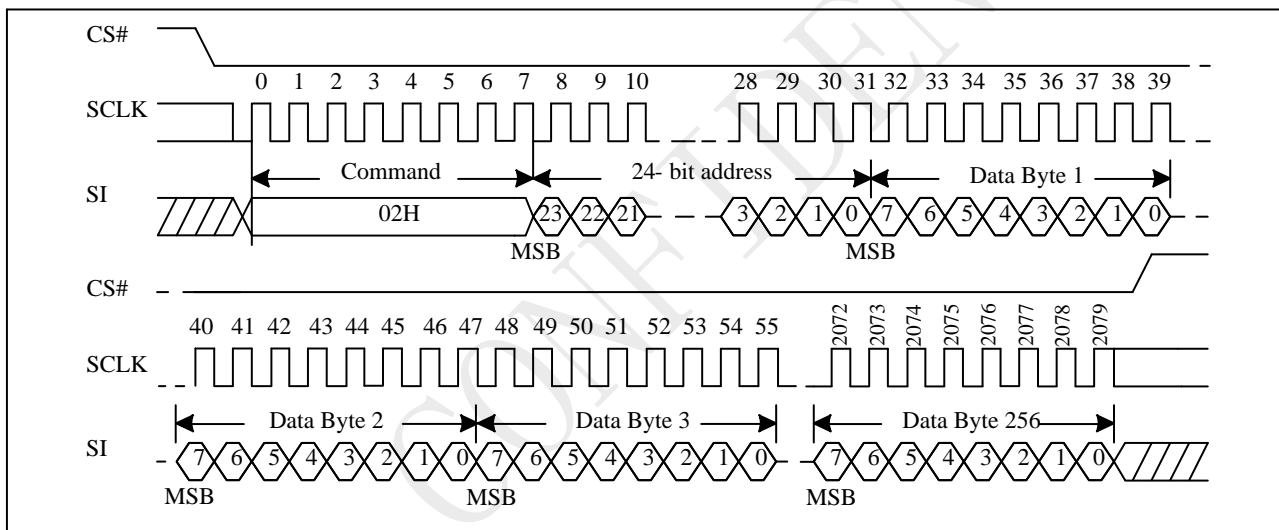

Note: 32-bit address is required when the device is operation in 4-byte address mode.

Figure 10-43a Page Program (PP) Sequence (QPI)

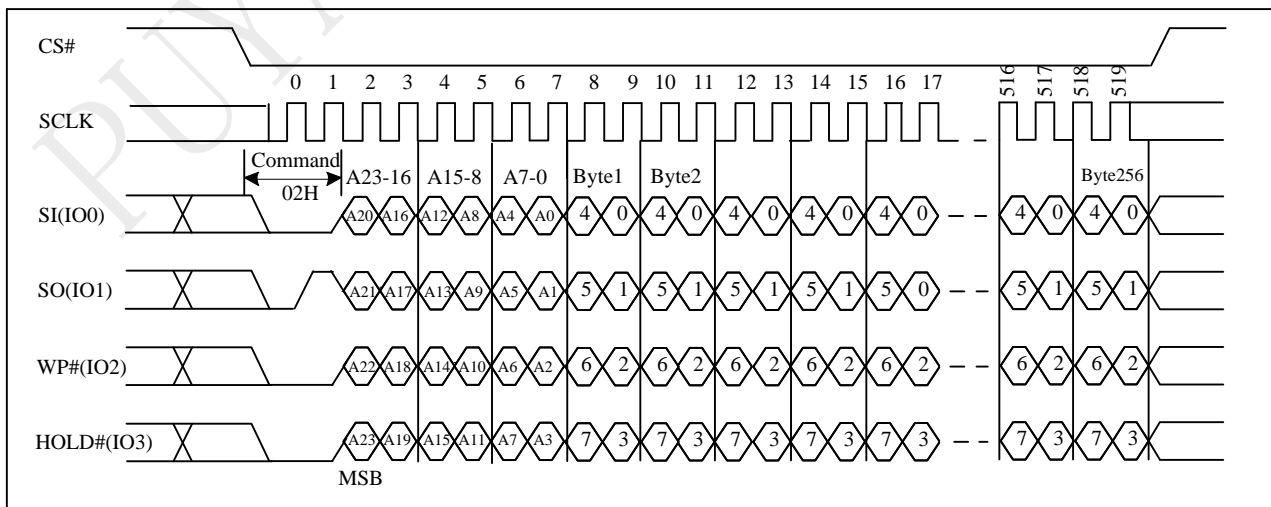

Note: 32-bit address is required when the device is operation in 4-byte address mode.

10.44 Page Program with 4-Byte Address (PP4B 12H)

The Page Program with 4-Byte Address instruction is similar to the Page Program instruction except that it requires 32-bit address instead of 24-bit address. No matter the device is operating in 3-Byte Address Mode or 4-byte Address Mode, the Page Program with 4-Byte Address instruction will always require 32-bit address to access the entire 512Mb memory

Figure 10-44 Page Program with 4-Byte Address Sequence (Command 12H)

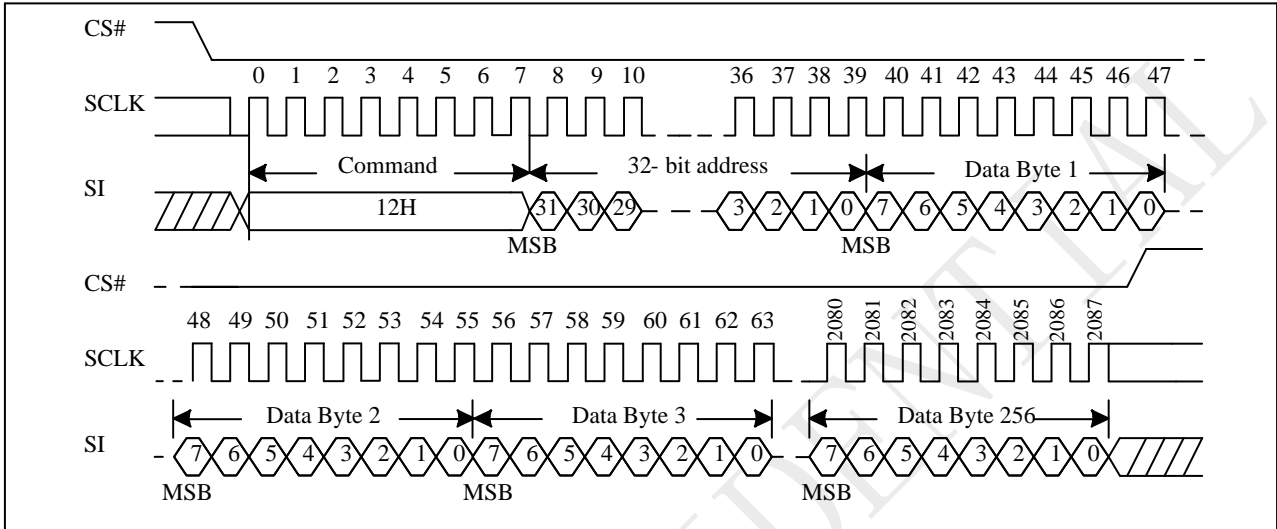

10.45 Quad Page Program (QPP 32H)

The Quad Page Program (QPP) instruction is for programming the memory to be "0". A Write Enable (WREN) instruction must execute to set the Write Enable Latch (WEL) bit and Quad Enable (QE) bit must be set to "1" before sending the Quad Page Program (QPP). The Quad Page Programming takes four pins: SIO0, SIO1, SIO2, and SIO3 as data input, which can improve programmer performance and the effectiveness of application. The QPP operation frequency supports as fast as fQPP. The other function descriptions are as same as standard page program.

The sequence of issuing QPP instruction is: CS# goes low → sending QPP instruction code → 3/4-byte address on SIO0 → at least 1-byte on data on SIO[3:0] → CS# goes high.

Figure 10-45 Quad Page Program (QPP) Sequence (Command 32H)

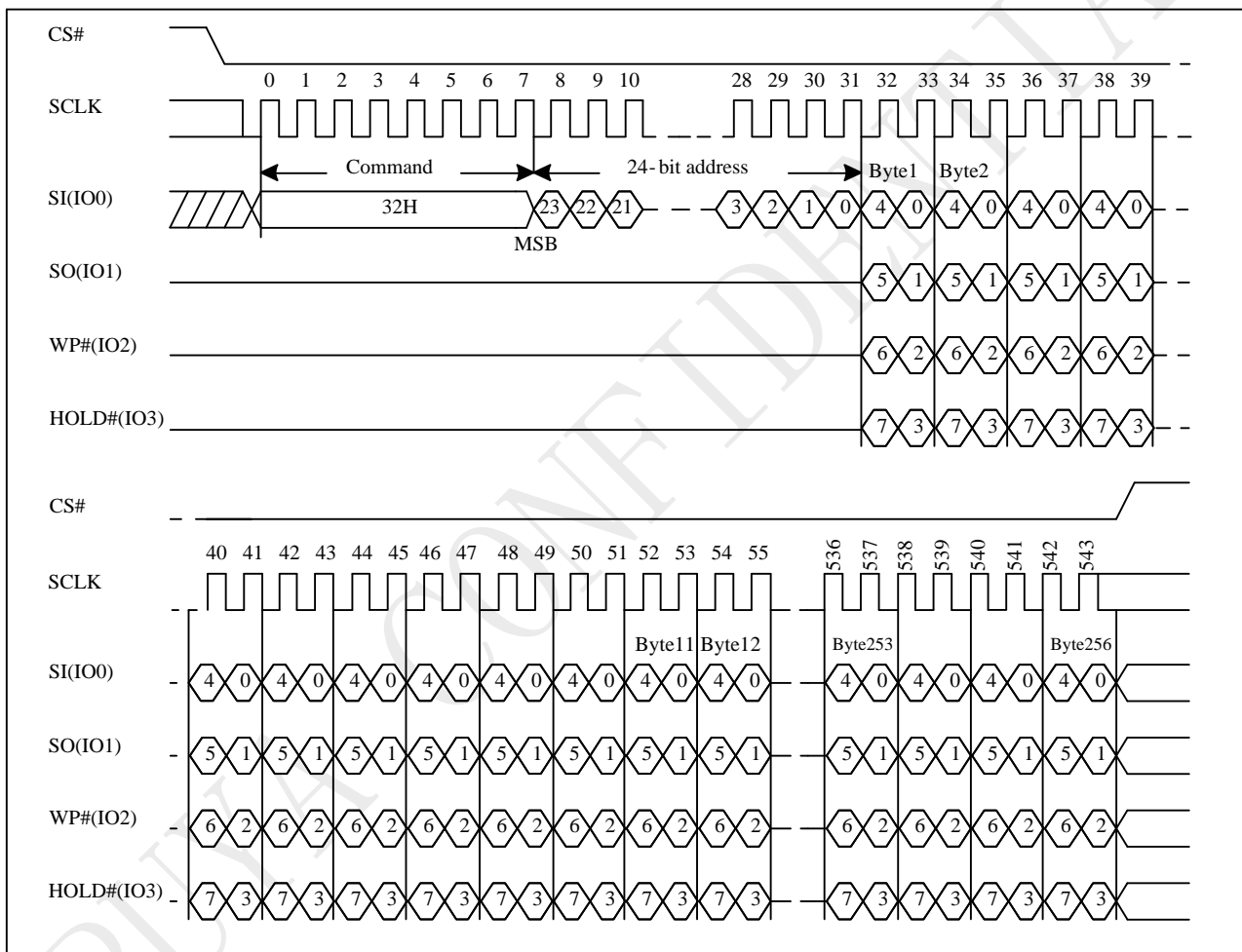

Note: 32-bit address is required when the device is operation in 4-byte address mode.



10.46 Quad Page Program with 4-Byte Address (QPP4B 34H)

The Quad Page Program with 4-Byte Address instruction is similar to the Quad Page Program instruction except that it requires 32-bit address instead of 24-bit address. No matter the device is operating in 3-Byte Address Mode or 4-byte Address Mode, the Quad Input Page Program with 4-Byte Address instruction will always require 32-bit address to access the entire 512Mb memory.

Figure 10-46 Quad Page Program with 4-Byte Address Sequence (Command 34H)

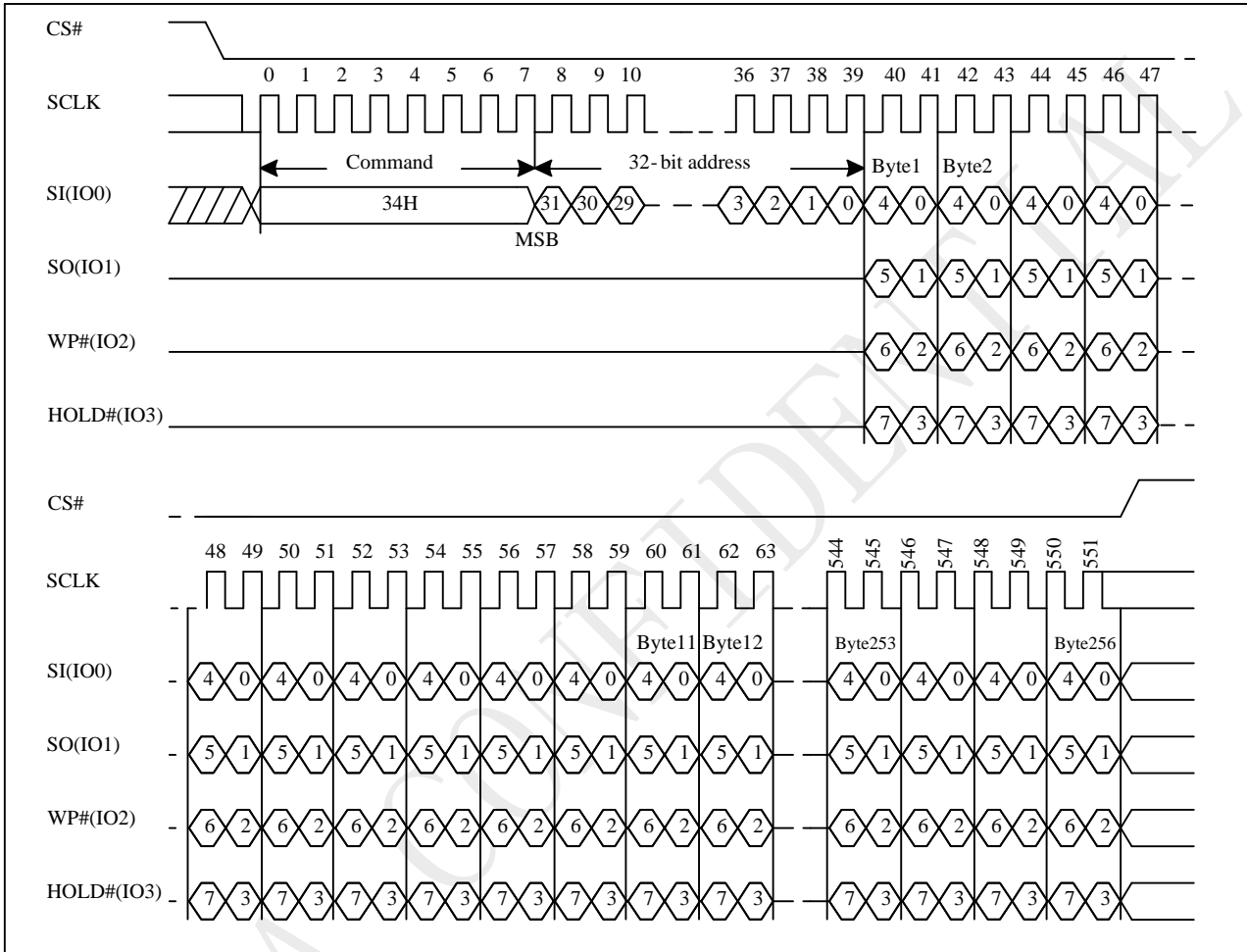

10.47 Quad-In Page Program (QIPP C2H)

The Quad-In Page Program (QIPP) instruction is for programming the memory to be "0". A Write Enable (WREN) instruction must execute to set the Write Enable Latch (WEL) bit and Quad Enable (QE) bit must be set to "1" before sending the Quad-In Page Program (QIPP). The Quad-In Page Programming takes four pins: SIO0, SIO1, SIO2, and SIO3 as address and data input, which can improve programmer performance and the effectiveness of application. The QIPP operation frequency supports as fast as fQPP. The other function descriptions are as same as standard page program.

The sequence of issuing QPP instruction is: CS# goes low → sending QIPP instruction code → 3/4-byte address on SIO[3:0] → at least 1-byte on data on SIO[3:0] → CS# goes high.

Figure 10-47 Quad Page Program (QPP) Sequence (Command C2H)

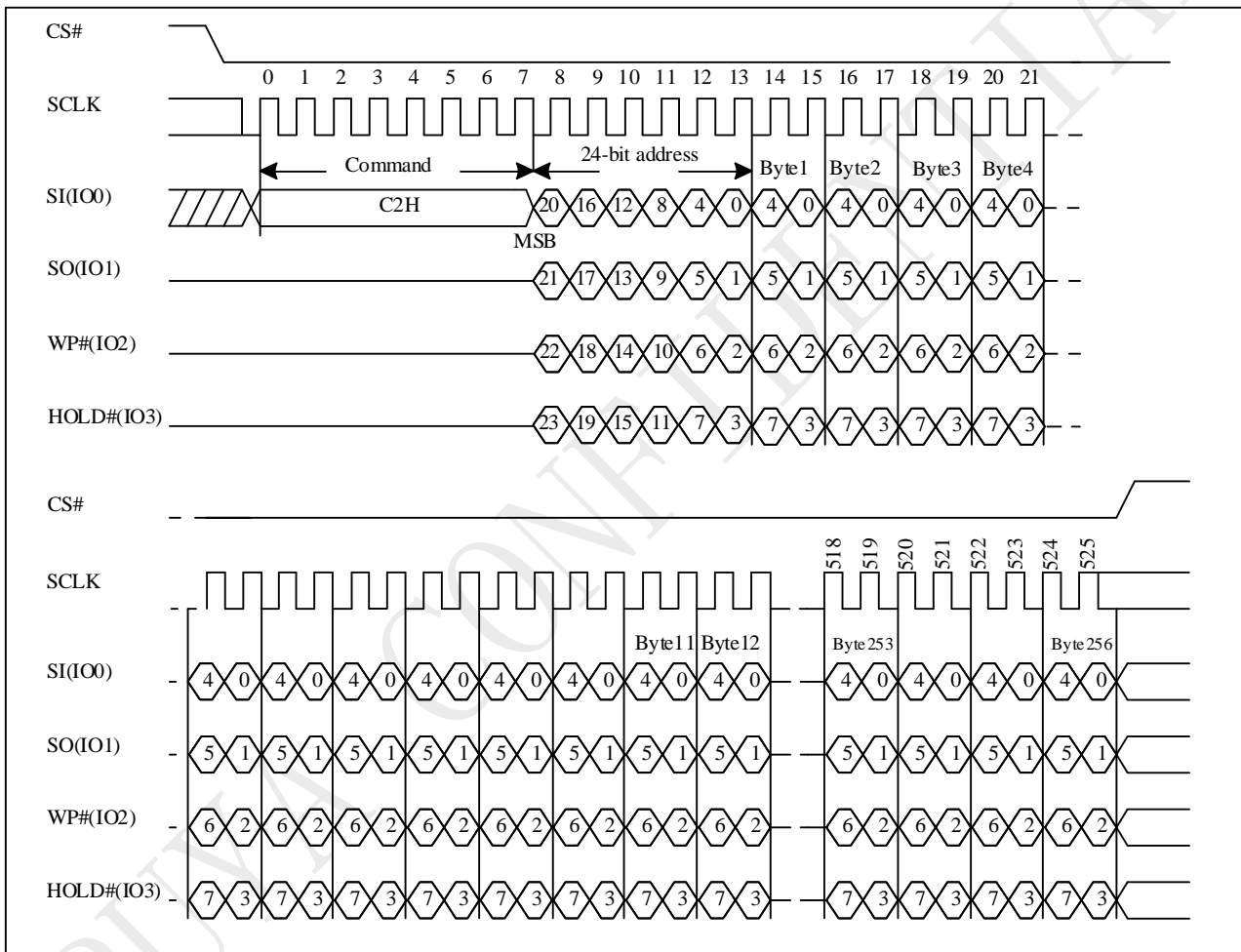

Note: 32-bit address is required when the device is operation in 4-byte address mode.



10.48 Quad-In Page Program with 4-Byte Address (QIPP4B 3EH)

The Quad-In Page Program with 4-Byte Address instruction is similar to the Quad-In Page Program instruction except that it requires 32-bit address instead of 24-bit address. No matter the device is operating in 3-Byte Address Mode or 4-byte Address Mode, the Quad Input Page Program with 4-Byte Address instruction will always require 32-bit address to access the entire 512Mb memory.

Figure 10-48 Quad-In Page Program with 4-Byte Address Sequence (Command 3EH)

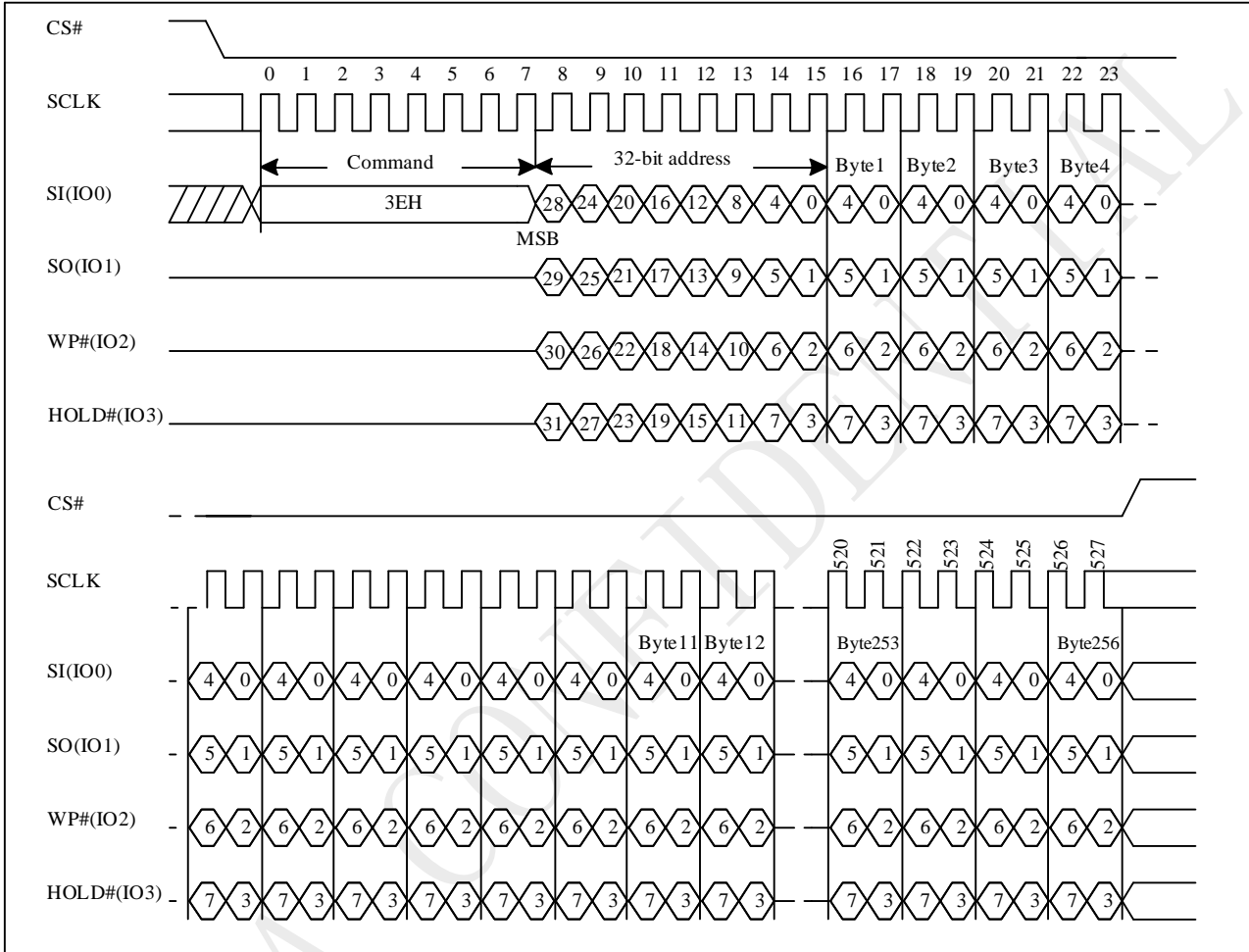

10.49 Erase Security Registers (ERSCUR 44H)

The product provides three 1024-byte Security Registers which can be erased and programmed individually. These registers may be used by the system manufacturers to store security and other important information separately from the main memory array. The Erase Security Registers command is similar to Sector/Block Erase command. A Write Enable (WREN) command must previously have been executed to set the Write Enable Latch (WEL) bit.

The Erase Security Registers command sequence: CS# goes low → sending ERSCUR instruction → sending 24/32-bit address → CS# goes high.

CS# must be driven high after the eighth bit of the command code has been latched in; otherwise the Erase Security Registers command is not executed. As soon as CS# is driven high, the self-timed Erase Security Registers cycle (tSE) is initiated. While the Erase Security Registers cycle is in progress, the Status Register may be read to check the value of the Write in Progress (WIP) bit. The Write in Progress (WIP) bit is 1 during the self-timed Erase Security Registers cycle, and is 0 when it is completed. The Security Registers Lock Bit (LB3-1) in the Status Register can be used to OTP protect the security registers. Once the LB bit is set to 1, the Security Registers will be permanently locked; the Erase Security Registers command will be ignored.

Address	A23/31-16	A15-12	A11-10	A9-0
Security Register #1	00H/0000H	0001	00	Don't care
Security Register #2	00H/0000H	0010	00	Don't care
Security Register #3	00H/0000H	0011	00	Don't care

Figure 10-49 Erase Security Registers (ERSCUR) Sequence (Command 44H)

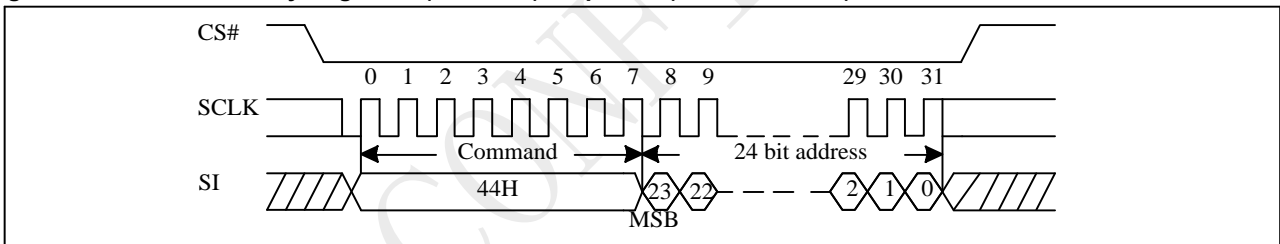
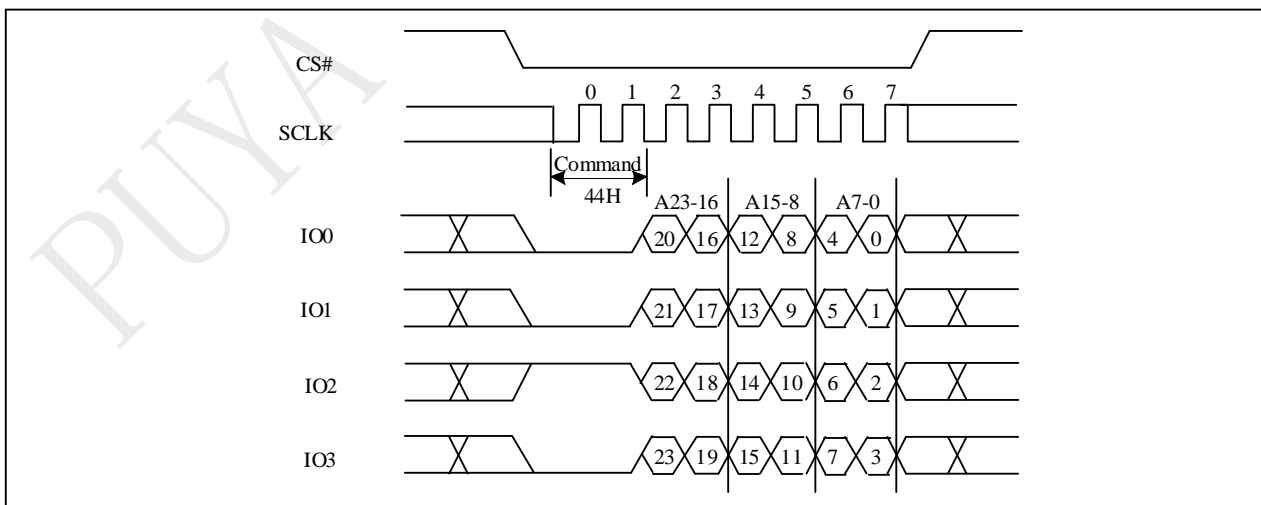

Figure 10-49a Erase Security Registers (ERSCUR) Sequence (QPI 44H)



Note: 32-bit address is required when the device is operation in 4-byte address mode.

10.50 Program Security Registers (PRSCUR 42H)

The Program Security Registers command is similar to the Page Program command. It allows from 1 to 1024 bytes Security Registers data to be programmed. A Write Enable (WREN) command must previously have been executed to set the Write Enable Latch (WEL) bit before sending the Program Security Registers command.

The Program Security Registers command sequence: CS# goes low → sending PRSCUR instruction → sending 24/32 bit address → sending at least one byte data → CS# goes high.

As soon as CS# is driven high, the self-timed Program Security Registers cycle (whose duration is tPP) is initiated. While the Program Security Registers cycle is in progress, the Status Register may be read to check the value of the Write in Progress (WIP) bit. The Write in Progress (WIP) bit is 1 during the self-timed Program Security Registers cycle, and is 0 when it is completed.

If the Security Registers Lock Bit (LB3-1) is set to 1, the Security Registers will be permanently locked. Program Security Registers command will be ignored.

Address	A23/31-16	A15-12	A11-10	A9-0
Security Register #1	00H/0000H	0001	00	Byte Address
Security Register #2	00H/0000H	0010	00	Byte Address
Security Register #3	00H/0000H	0011	00	Byte Address

Figure 10-50 Program Security Registers (PRSCUR) Sequence (Command 42H)

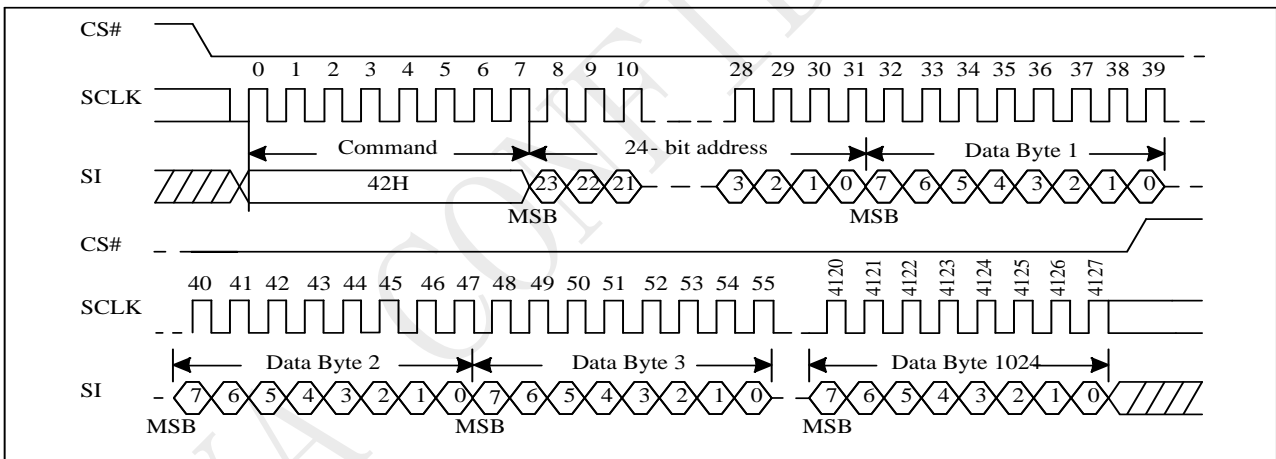
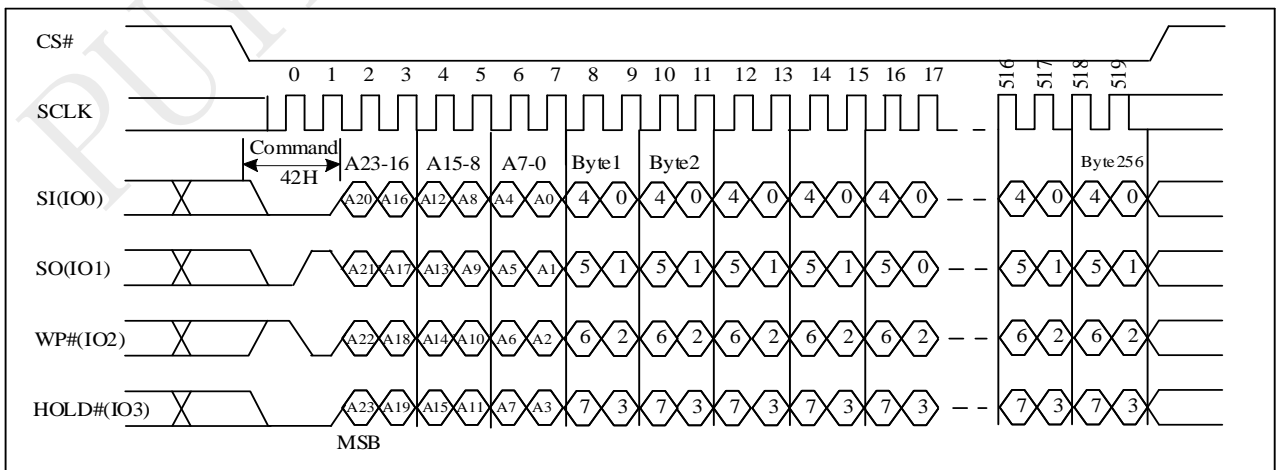

Figure 10-48a Program Security Registers (PRSCUR) Sequence (QPI 42H)



Note:32-bit address is required when the device is operation in 4-byte address mode.

10.51 Read Security Registers (RDSCUR 48H)

The Read Security Registers command is similar to Fast Read command. The command is followed by a 3/4-byte address (A23/31-A0) and a dummy byte, each bit being latched-in during the rising edge of SCLK. Then the memory content, at that address, is shifted out on SO, each bit being shifted out, at a Max frequency fC, during the falling edge of SCLK. The first byte addressed can be at any location. The address is automatically incremented to the next higher address after each byte of data is shifted out. Once the A9-A0 address reaches the last byte of the register (Byte 3FFH), it will reset to 000H, the command is completed by driving CS# high.

The sequence of issuing RDSCUR instruction is: CS# goes low → sending RDSCUR instruction → sending 24/32 bit address → 8 bit dummy byte → Security Register data out on SO → CS# goes high.

Address	A23/31-16	A15-12	A11-10	A9-0
Security Register #1	00H/0000H	0001	00	Byte Address
Security Register #2	00H/0000H	0010	00	Byte Address
Security Register #3	00H/0000H	0011	00	Byte Address

Figure 10-51 Read Security Registers (RDSCUR) Sequence (Command 48H)

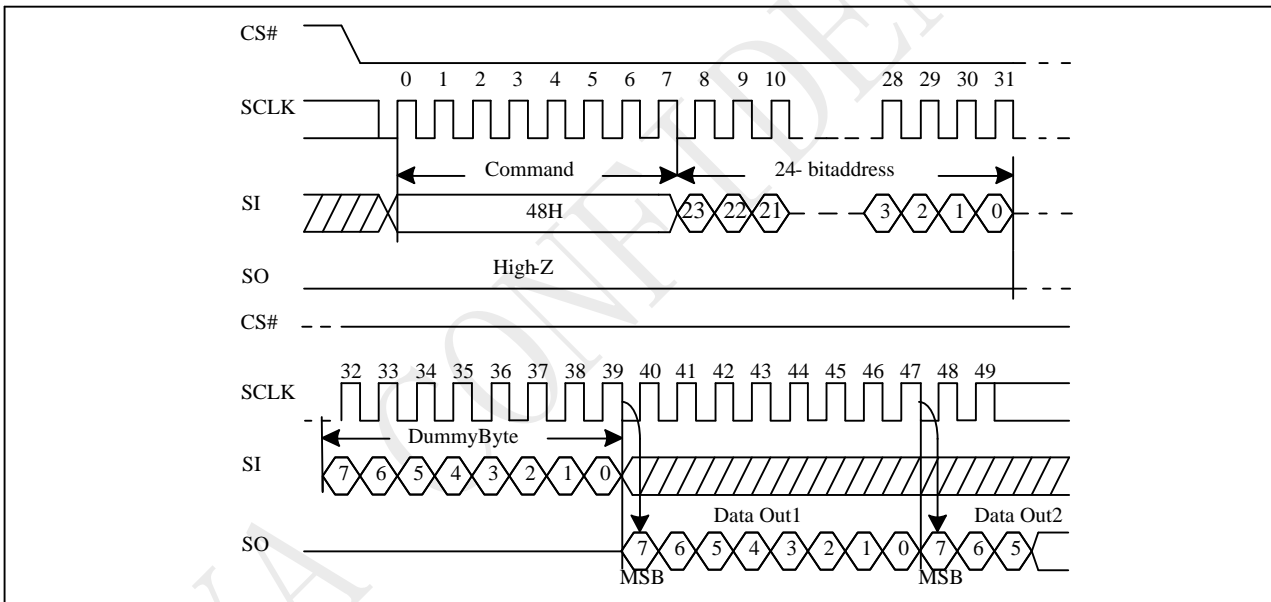
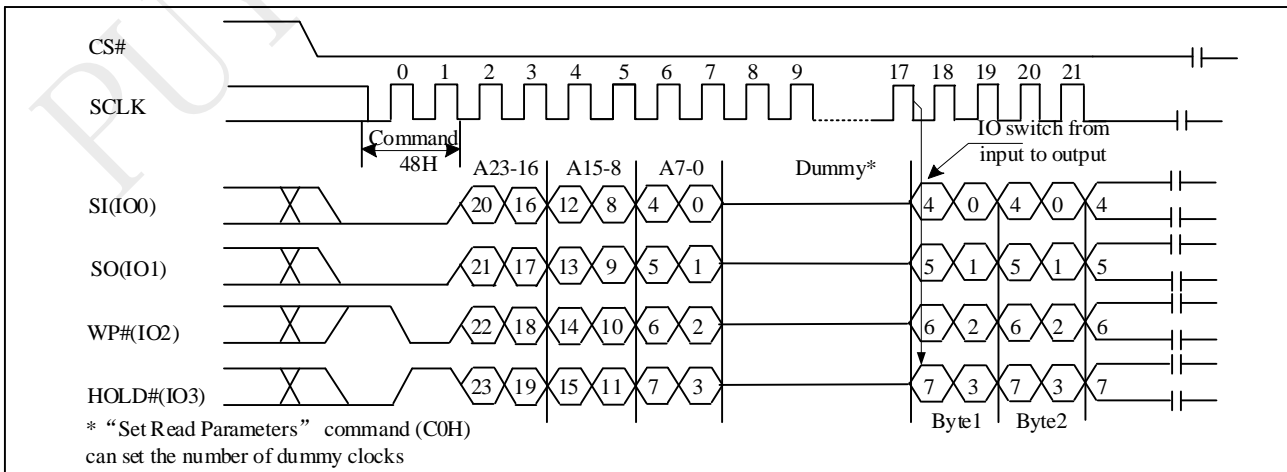

Figure 10-51a Read Security Registers (RDSCUR) Sequence (QPI 48H)



Note:32-bit address is required when the device is operation in 4-byte address mode.

10.52 Deep Power-down (DP B9H)

The Deep Power-down (DP) instruction is for setting the device on the minimizing the power consumption (to entering the Deep Power-down mode), the standby current is reduced from ISB1 to ISB2). The Deep Power-down mode requires the Deep Power-down (DP) instruction to enter, during the Deep Power-down mode, the device is not active and all Write/Program/Erase instruction are ignored. When CS# goes high, it's only in standby mode not deep power-down mode. It's different from Standby mode.

The sequence of issuing DP instruction is: CS# goes low → sending DP instruction code → CS# goes high.

Once the DP instruction is set, all instruction will be ignored except the Release from Deep Power-down mode (RDP), Read Electronic Signature (RES) instruction (RES instruction to allow the ID been read out), and software reset instruction. When Power-down, the deep power-down mode automatically stops, and when power-up, the device automatically is in standby mode. For RDP instruction the CS# must go high exactly at the byte boundary (the latest eighth bit of instruction code been latched-in); otherwise, the instruction will not be executed. As soon as Chip Select (CS#) goes high, a delay of t_{DP} is required before entering the Deep Power-down mode and reducing the current to I_{DPD} .

In SPI Deep Power-down mode, the SPI software reset instruction(66H+99H) can exit Deep Power-down mode; while in QPI Deep Power-down mode, the QPI software reset instruction(66H+99H) can exit Deep Power-down mode.

Figure 10-52 Deep Power-down (DP) Sequence (Command B9H)

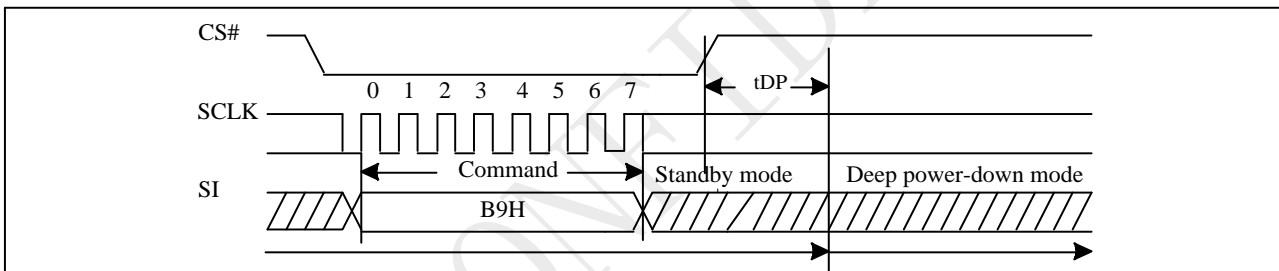
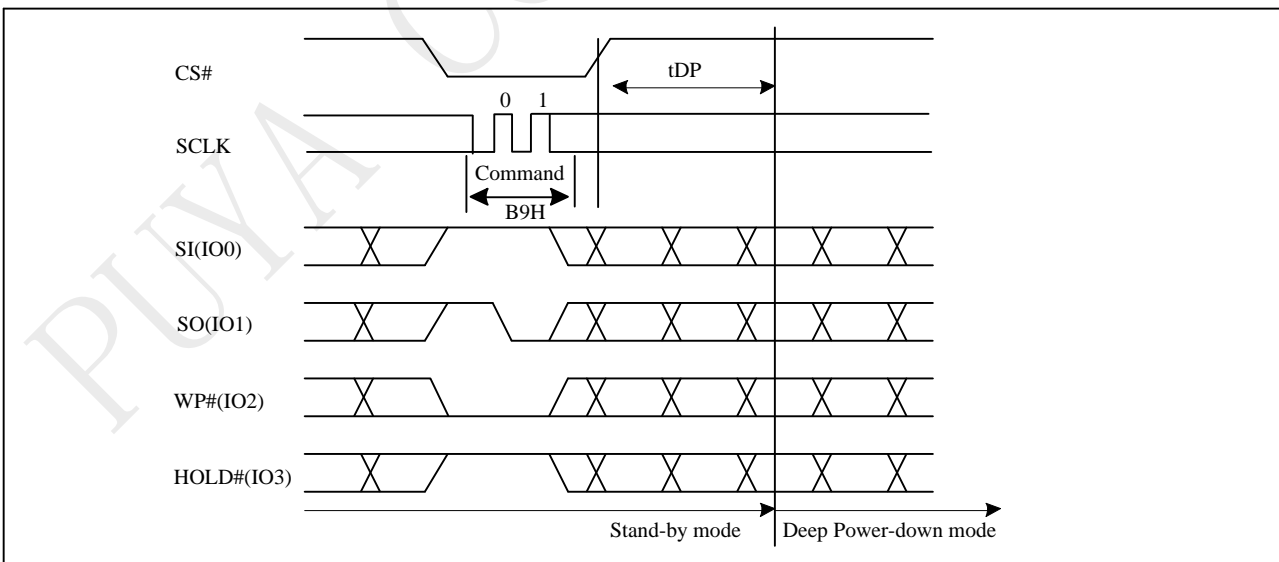

Figure 10-52a Deep Power-down (DP) Sequence (QPI)



10.53 Release from Deep Power-Down (RDP), Read Electronic Signature (RES ABH)

The Release from Deep Power-down (RDP) instruction is terminated by driving Chip Select (CS#) High. When Chip Select (CS#) is driven high, the device is put in the Stand-by Power mode. If the device was not previously in the Deep Power-down mode, the transition to the Stand-by Power mode is immediate. If the device was previously in the Deep Power-down mode, though, the transition to the Stand-by Power mode is delayed by t_{RES2} , and Chip Select (CS#) must remain High for at least $t_{RES2(max)}$. Once in the Stand-by Power mode, the device waits to be selected, so that it can receive, decode and execute instructions.

RES instruction is for reading out the old style of 8-bit Electronic Signature, whose values are shown as table of ID Definitions. This is not the same as RDID instruction. It is not recommended to use for new design. For new design, please use RDID instruction. Even in Deep power-down mode, the RDP and RES are also allowed to be executed, only except the device is in progress of program/erase/write cycle; there's no effect on the current program/erase/ write cycle in progress.

The RES instruction is ended by CS# goes high after the ID been read out at least once. The ID outputs repeatedly if continuously send the additional clock cycles on SCLK while CS# is at low. If the device was not previously in Deep Power-down mode, the device transition to standby mode is immediate. If the device was previously in Deep Power-down mode, there's a delay of t_{RES2} to transit to standby mode, and CS# must remain to high at least t_{RES2} (max). Once in the standby mode, the device waits to be selected, so it can be receive, decode, and execute instruction.

The RDP instruction is for releasing from Deep Power-Down Mode.

Figure 10-53 Read Electronic Signature (RES) Sequence (Command ABH)

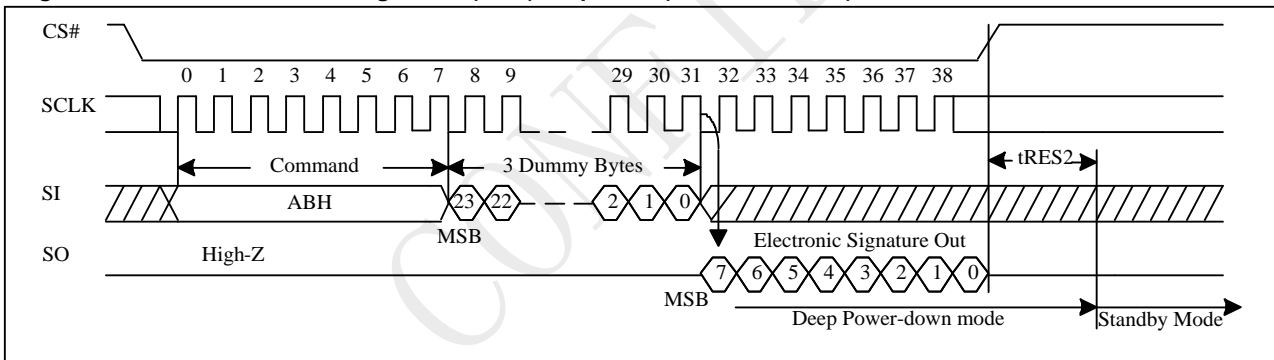

Figure 10-53a Read Electronic Signature (RES) Sequence (QPI)

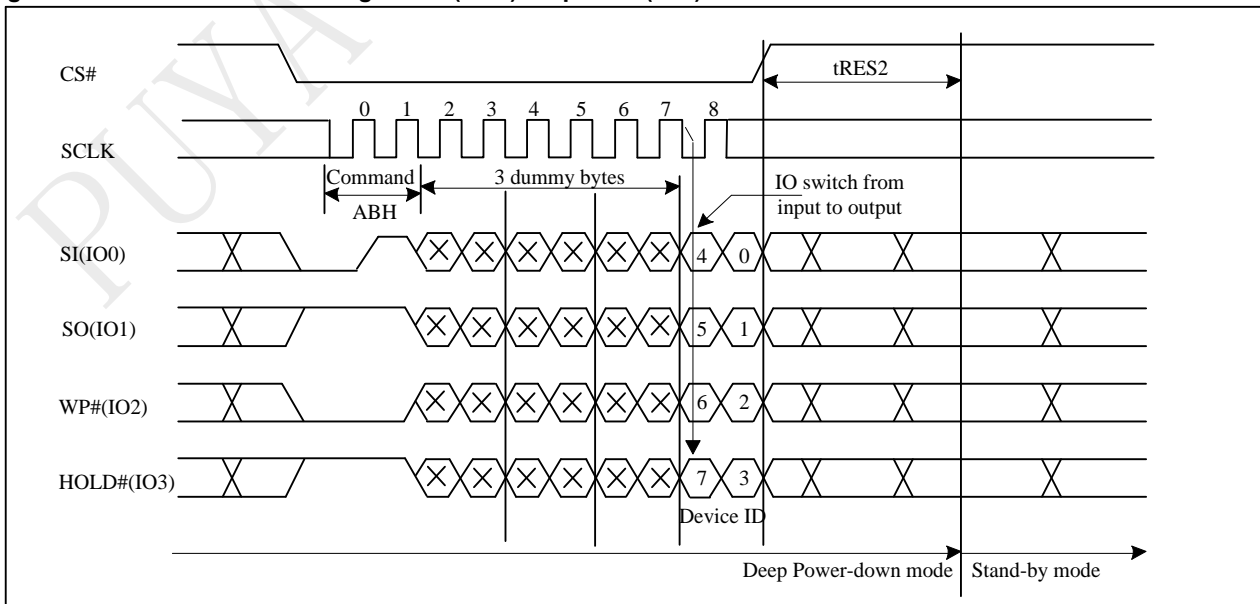

Figure 10-53b Release from Deep Power-down (RDP) Sequence (Command ABH)

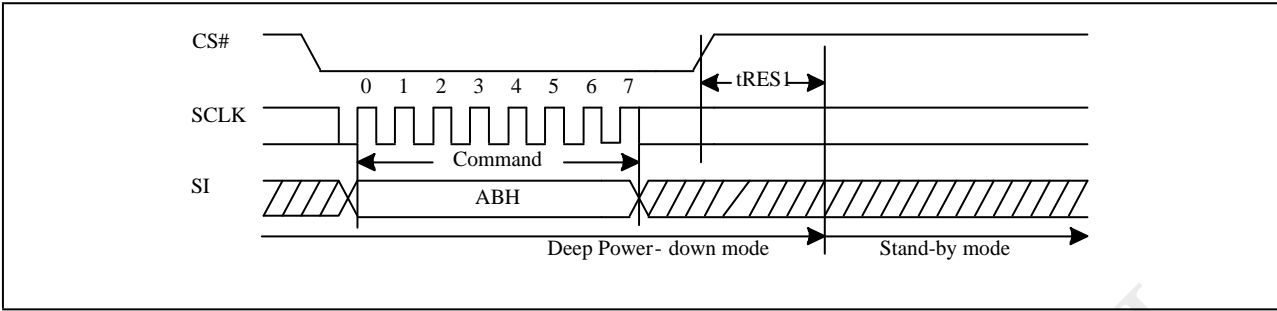
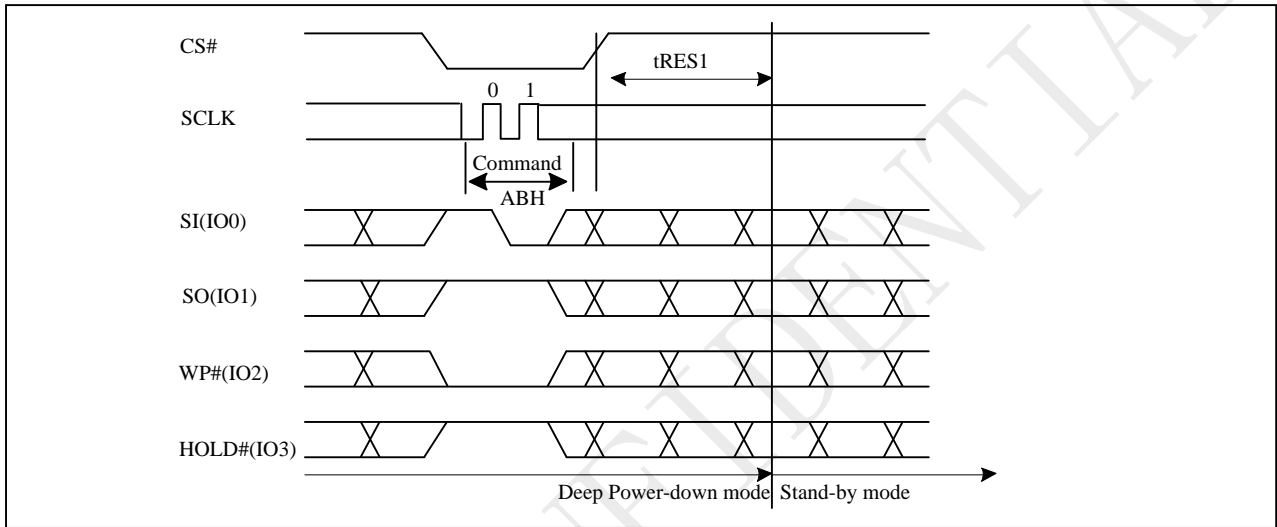

Figure 10-53c Release from Deep Power-down (RDP) Sequence (QPI)



10.54 Read Electronic Manufacturer ID & Device ID (REMS 90H)

The REMS instruction returns both the JEDEC assigned manufacturer ID and the device ID. The Device ID values are listed in "Table ID Definitions".

The REMS instruction is initiated by driving the CS# pin low and sending the instruction code "90h" followed by a 24-bit address (A23 -A0) of 000000H. After which the manufacturer ID for PUYA (85h) and the device ID are shifted out on the falling edge of SCLK with the most significant bit (MSB) first. While CS# is low, the manufacturer and device IDs can be read continuously, alternating from one to the other. The instruction is completed by driving CS# high.

Figure 10-54 Read Electronic Manufacturer & Device ID (REMS) Sequence (Command 90H)

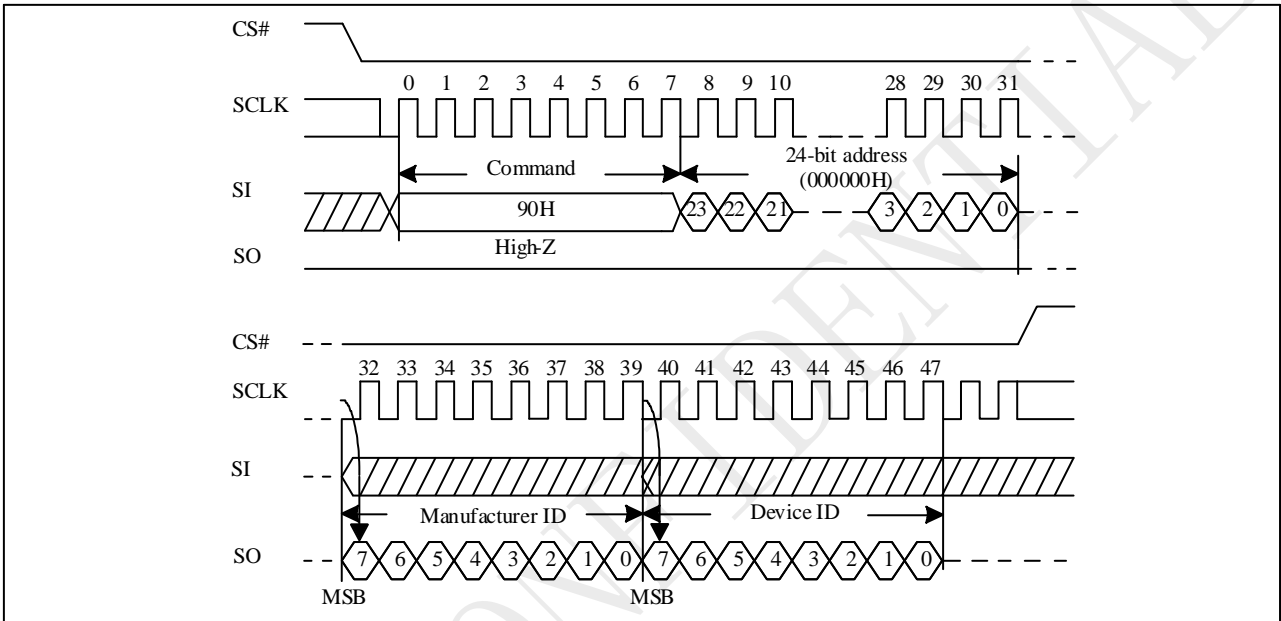
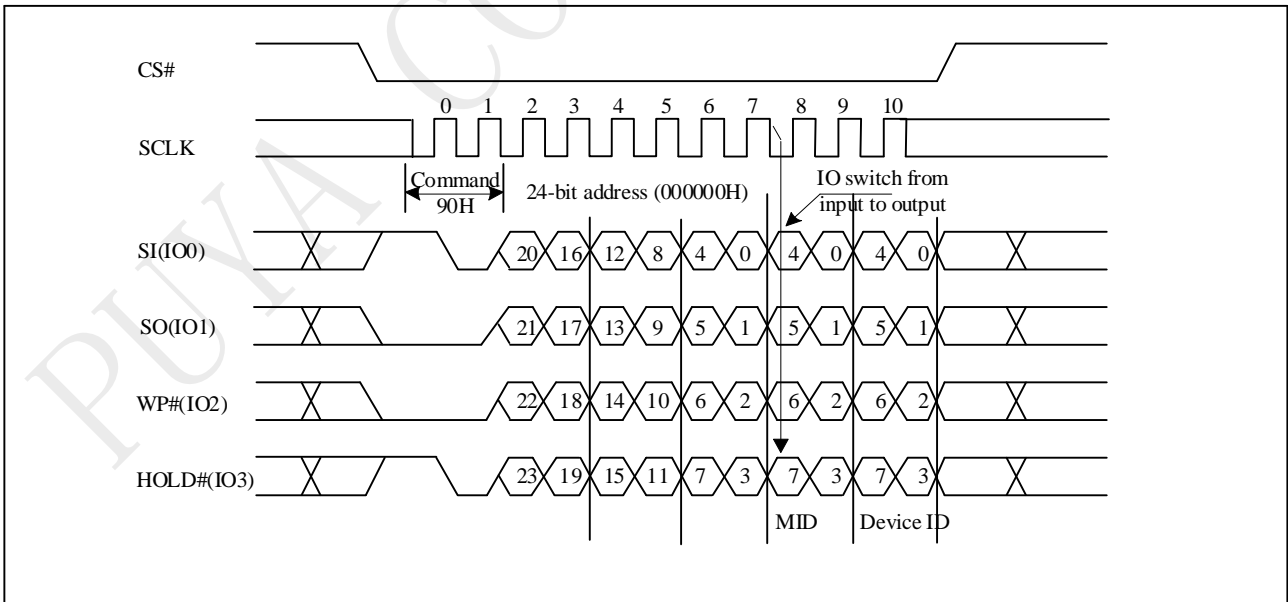

Figure 10-54a Read Electronic Manufacturer & Device ID (REMS) Sequence (QPI)



10.55 Dual I/O Read Electronic Manufacturer ID & Device ID (DREMS 92H)

The DREMS instruction is similar to the REMS command and returns the JEDEC assigned manufacturer ID which takes two pins: SIO0, SIO1 as address input and ID output I/O

The instruction is initiated by driving the CS# pin low and shift the instruction code "92h" followed by a 24/32-bit address (A23/A31-A0) of 000000h and 1byte dummy, but with the capability to input the Address bits two bits per clock. After which, the Manufacturer ID for PUYA (85h) and the Device ID are shifted out on the falling edge of SCLK with most significant bit (MSB) first. The Manufacturer and Device IDs can be read continuously, alternating from one to the other. The instruction is completed by driving CS# high.

Figure 10-55 DUAL I/O Read Electronic Manufacturer & Device ID (DREMS) Sequence (Command 92H)

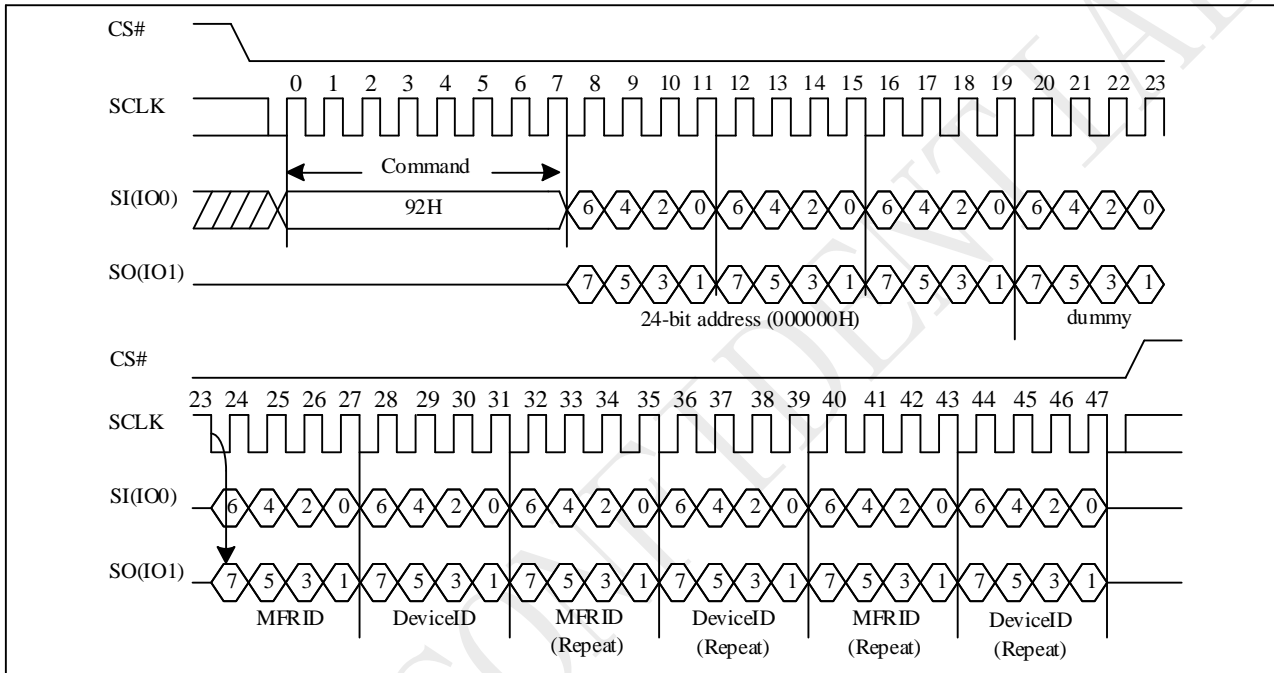

Note: 32-bit address (0000_0000H) are required when the device is operation in 4-byte address mode.

10.56 Quad I/O Read Electronic Manufacturer ID & Device ID (QREMS 94H)

The QREMS instruction is similar to the REMS command and returns the JEDEC assigned manufacturer ID which takes four pins: SIO0, SIO1, SIO2, SIO3 as address input and ID output I/O

The instruction is initiated by driving the CS# pin low and shift the instruction code "94h" followed by a 24/32-bit address (A23/A31-A0) of 000000h, and 3 bytes dummy, but with the capability to input the Address bits four bits per clock. After which, the Manufacturer ID for PUYA (85h) and the Device ID are shifted out on the falling edge of SCLK with most significant bit (MSB) first. The Manufacturer and Device IDs can be read continuously, alternating from one to the other. The instruction is completed by driving CS# high.

Figure 10-56 QUAD I/O Read Electronic Manufacturer & Device ID (QREMS) Sequence (Command 94H)

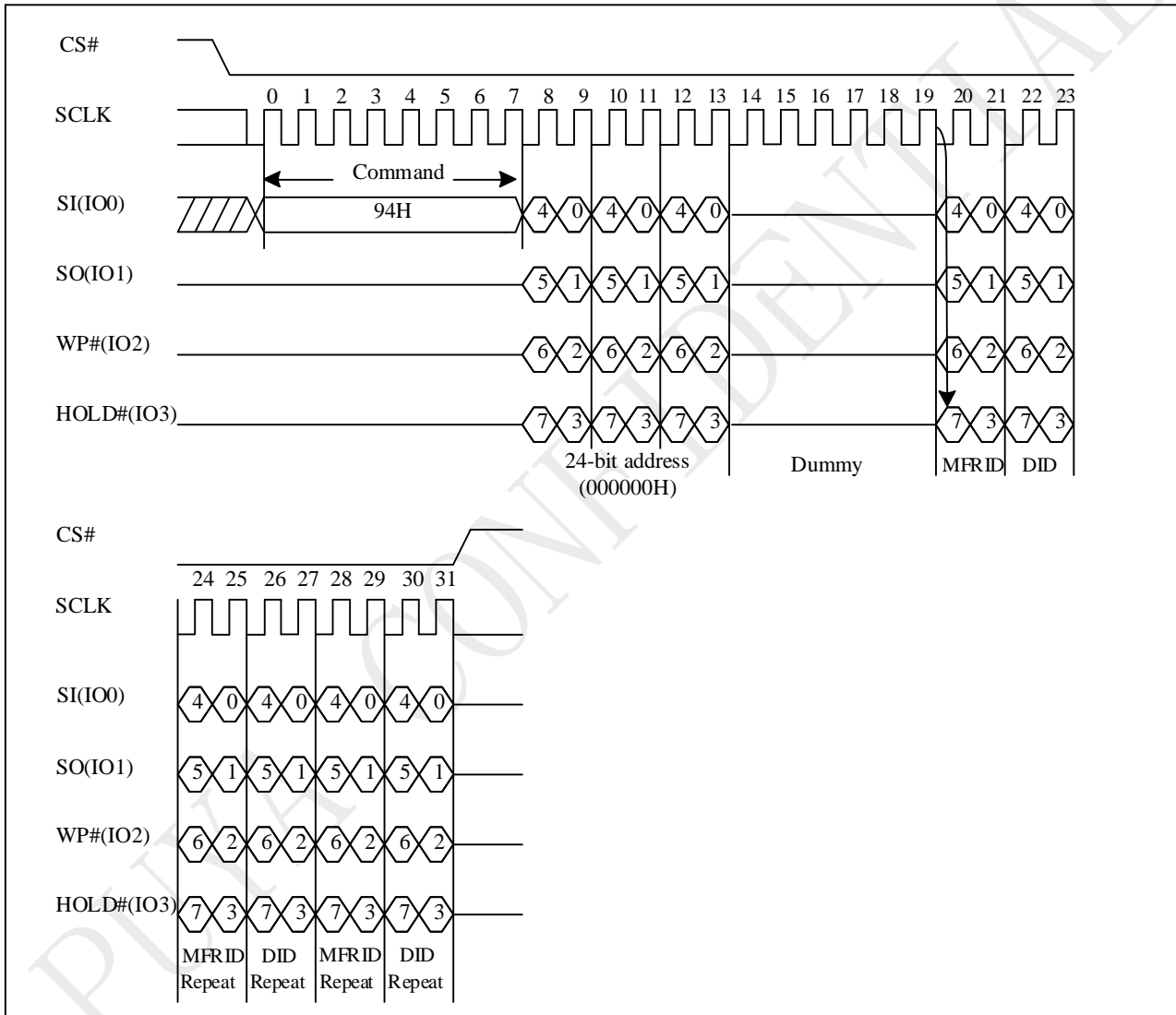

Note: 32-bit address (0000_0000H) are required when the device is operation in 4-byte address mode.

10.57 Read Identification (RDID 9FH)

The RDID instruction is for reading the manufacturer ID of 1-byte and followed by Device ID of 2-byte. The PUYA Manufacturer ID and Device ID are list as "Table. ID Definitions".

The sequence of issuing RDID instruction is: CS# goes low → sending RDID instruction code → 24-bits ID data out on SO → to end RDID operation can use CS# to high at any time during data out. While Program/Erase operation is in progress, it will not decode the RDID instruction, so there's no effect on the cycle of program/erase operation which is currently in progress. When CS# goes high, the device is at standby stage.

Figure 10-57 Read Identification (RDID) Sequence (Command 9FH)

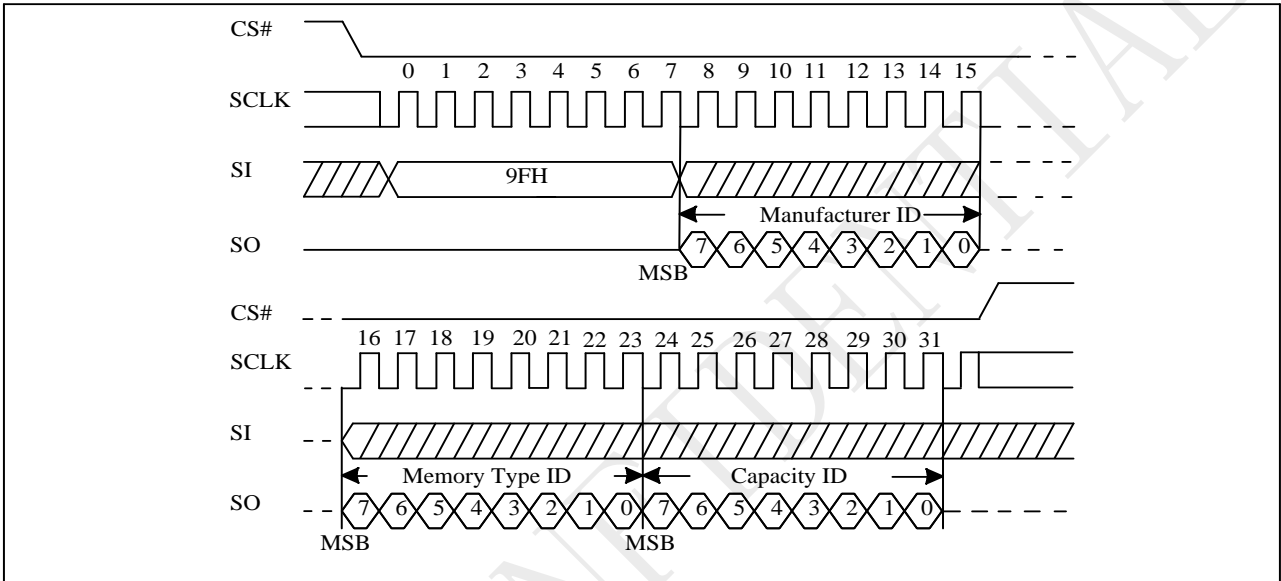

Figure 10-57a Read Identification (RDID) Sequence (QPI)

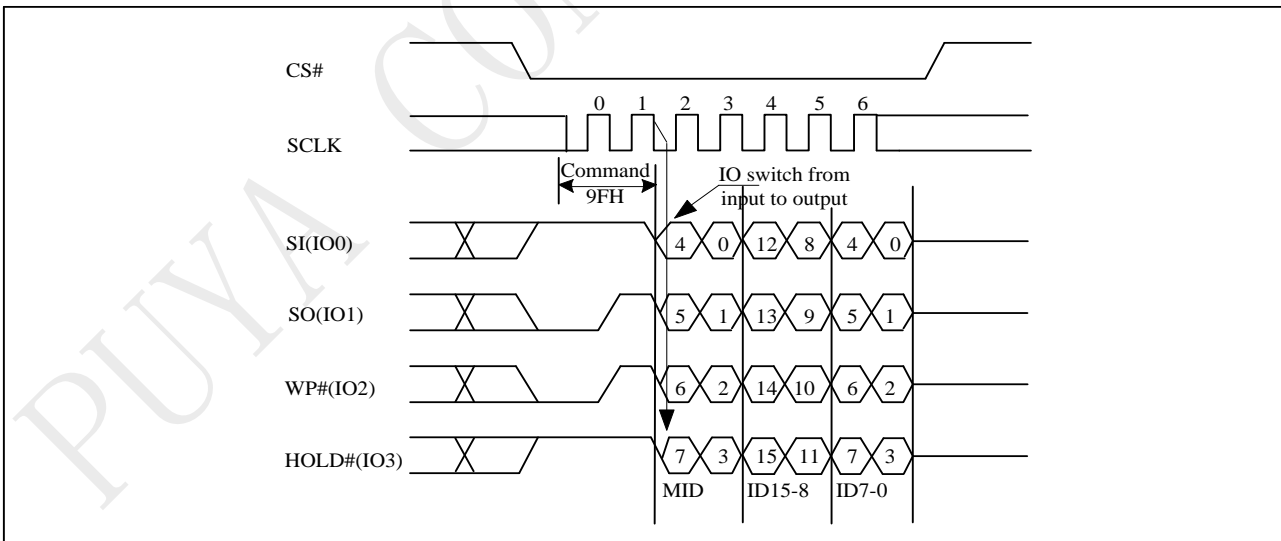

Table ID Definitions

PY25Q512HB-Auto	RDID command	manufacturer ID	memory type	memory density
			85	20
	RES command	electronic ID		
		19		
	REMS command	manufacturer ID	device ID	
		85	19	



10.58 Program/Erase Suspend (75H)

The Suspend instruction interrupts a Page Program, Page Erase, Sector Erase, or Block Erase operation to allow access to the memory array. After the program or erase operation has entered the suspended state, the memory array can be read except for the page being programmed or the sector or block being erased.

Readable Area of Memory While a Program or Erase Operation is Suspended

Suspended Operation	Readable Region of Memory Array
Page Program	All but the Page being programmed
Sector Erase(4KB)	All but the 4KB Sector being erased
Block Erase(32KB)	All but the 32KB Block being erased
Block Erase(64KB)	All but the 64KB Block being erased

When the Serial NOR Flash receives the Suspend instruction, there is a latency of tPSL or tESL before the Write Enable Latch (WEL) bit clears to "0" and the SUS sets to "1", after which the device is ready to accept one of the commands listed in "Table Acceptable Commands During Program/Erase Suspend after tPSL/tESL" (e.g. FAST READ). Refer to "AC Characteristics" for tPSL and tESL timings. "Table Acceptable Commands During Suspend (tPSL/tESL not required)" lists the commands for which the tPSL and tESL latencies do not apply. For example, RDSR, RDSCUR, RSTEN, and RST can be issued at any time after the Suspend instruction.

Status Register bit 15 (SUS) can be read to check the suspend status. The SUS (Program/Erase Suspend Bit) sets to "1" when a program or erase operation is suspended. The SUS clears to "0" when the program or erase operation is resumed

Acceptable Commands During Program/Erase Suspend after tPSL/tESL

Command name	Command Code	Suspend Type	
		Program Suspend	Erase Suspend
READ	03H	•	•
READ4B	13H	•	•
FREAD	0BH	•	•
DTRFRD	0DH	•	•
FREAD4B	0CH	•	•
DREAD	3BH	•	•
DREAD4B	3CH	•	•
QREAD	6BH	•	•
2READ	BBH	•	•
2DTRD	BDH	•	•
2READ4B	BCH	•	•
4READ	EBH	•	•
4READ4B	ECH	•	•
4DTRD	EDH	•	•
4DTRD4B	EEH	•	•
Burst Read with Wrap	0CH	•	•
DTR Burst Read with Wrap	0EH	•	•
QPIEN	38H	•	•
Disable QPI	FFH	•	•
RDSFDP	5AH	•	•
RDID	9FH	•	•
EN4B	B7H	•	•
EX4B	E9H	•	•
REMS	90H	•	•
DREMS	92H	•	•
QREMS	94H	•	•
RDSCUR	48H	•	•
SBL	77H	•	•
Set Read Parameter	C0H	•	•



Command name	Command Code	Suspend Type	
		Program Suspend	Erase Suspend
WREN	06H		•
RESUME	7AH	•	•
PP	02H		•
PP4B	12H		•
QPP	32H		•
QPP4B	34H		•
QIPP	C2H		•
QIPP4B	3EH		•

Acceptable Commands During Suspend (tPSL/tESL not required)

Command name	Command Code	Suspend Type	
		Program Suspend	Erase Suspend
WRDI	04H	•	•
RDSR	05H	•	•
RDSR2	35H	•	•
RDCR	15H	•	•
RES	ABH	•	•
RSTEN	66H	•	•
RST	99H	•	•
NOP	00H	•	•

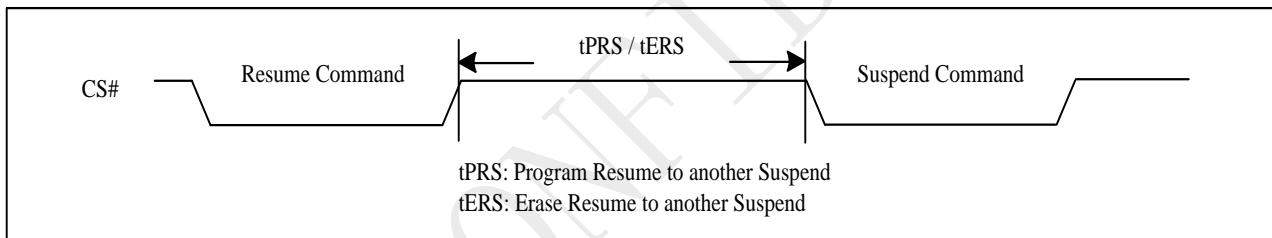
Figure 10-58 Resume to Suspend Latency

10.59 Erase Suspend to Program

The “Erase Suspend to Program” feature allows Page Programming while an erase operation is suspended. Page Programming is permitted in any unprotected memory except within the sector of a suspended Sector Erase operation or within the block of a suspended Block Erase operation. The Write Enable (WREN) instruction must be issued before any Page Program instruction.

A Page Program operation initiated within a suspended erase cannot itself be suspended and must be allowed to finish before the suspended erase can be resumed. The Status Register can be polled to determine the status of the Page Program operation. The WEL and WIP bits of the Status Register will remain “1” while the Page Program operation is in progress and will both clear to “0” when the Page Program operation completes.

Figure 10-59 Suspend to Read/Program Latency

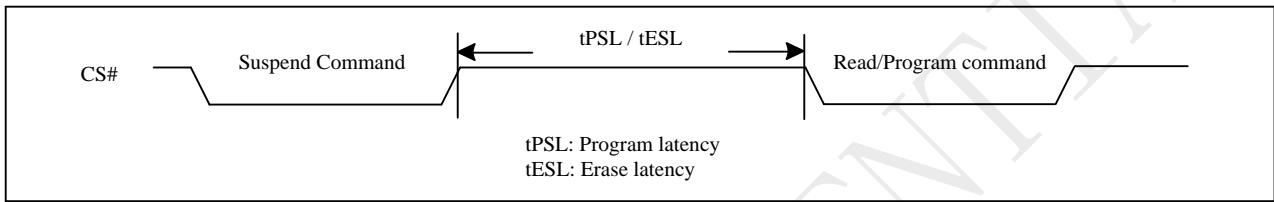
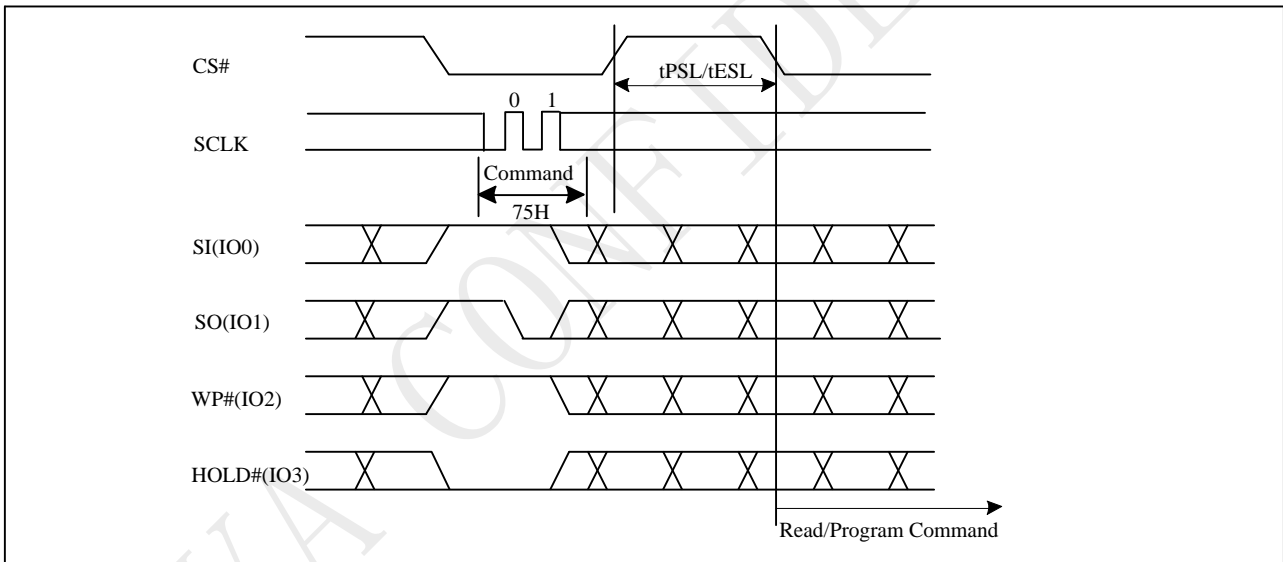

Figure 10-59a Suspend to Read/Program Latency(QPI)



Notes:

1. Please note that Program only available after the Erase-Suspend operation
2. To check suspend ready information, please read status register bit15 (SUS2) and bit10(SUS1)

10.60 Program Resume and Erase Resume (7AH)

The Resume instruction resumes a suspended Page Program, Page Erase, Sector Erase, or Block Erase operation. Before issuing the Resume instruction to restart a suspended erase operation, make sure that there is no Page Program operation in progress.

Immediately after the Serial NOR Flash receives the Resume instruction, the WEL and WIP bits are set to "1" and the SUS2 or SUS1 is cleared to "0". The program or erase operation will continue until finished ("Resume to Read Latency") or until another Suspend instruction is received. A resume-to-suspend latency of t_{PRS} or t_{ERS} must be observed before issuing another Suspend instruction ("Resume to Suspend Latency").

Figure 10-60 Resume to Read Latency

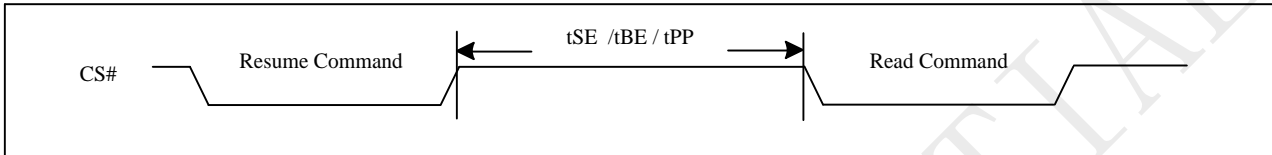
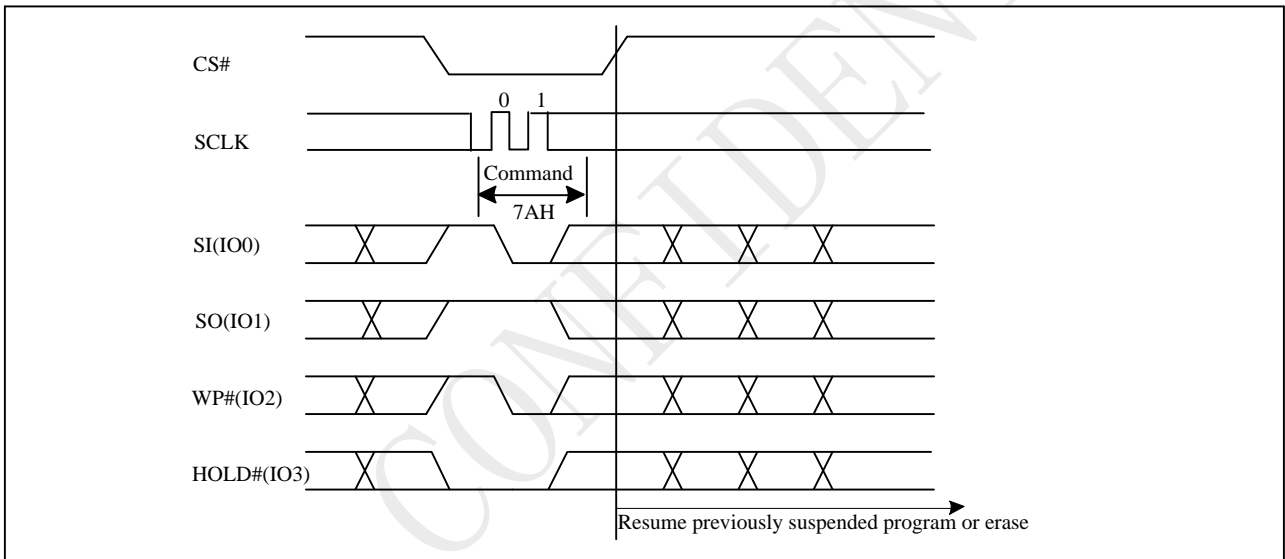

Figure 10-60a Resume to Read Latency (QPI)



10.61 No Operation (NOP)

The "No Operation" command is only able to terminate the Reset Enable (RSTEN) command and will not affect any other command.

The SIO[3:1] are don't care.

10.62 Individual Block Lock (SBLK 36H)

The Individual Block Lock provides an alternative way to protect the memory array from adverse Erase/Program. In order to use the Individual Block Locks, the WPS bit in Configure Register must be set to 1. If WPS=0, the write protection will be determined by the combination of CMP, BP[4:0] bits in the Status Registers. The Individual Block Lock bits are volatile bits. The default values after device power up or after a Reset are 1, so the entire memory array is being protected.

The SBLK instruction is for write protection a specified block (or sector) of memory, using AMAX-A16 or (AMAX-A12) address bits to assign a 64Kbyte block (or 4K bytes sector) to be protected as read only.

The WREN (Write Enable) instruction is required before issuing SBLK instruction.

The sequence of issuing SBLK instruction is: CS# goes low → send SBLK (36h) instruction → send 3/4-byte address assign one block (or sector) to be protected on SI pin → CS# goes high. The CS# must go high exactly at the byte boundary, otherwise the instruction will be rejected and not be executed.

Figure 10-62 Individual Block Lock (Command 36H)

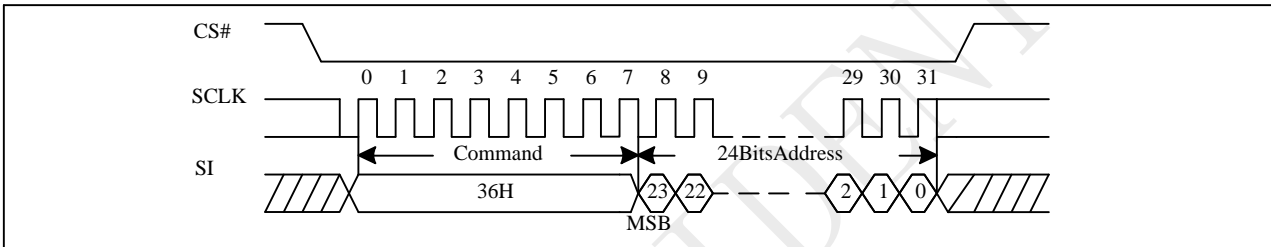

Note: 32-bit address is required when the device is operation in 4-byte address mode.

Figure 10-62a Individual Block Lock(QPI)

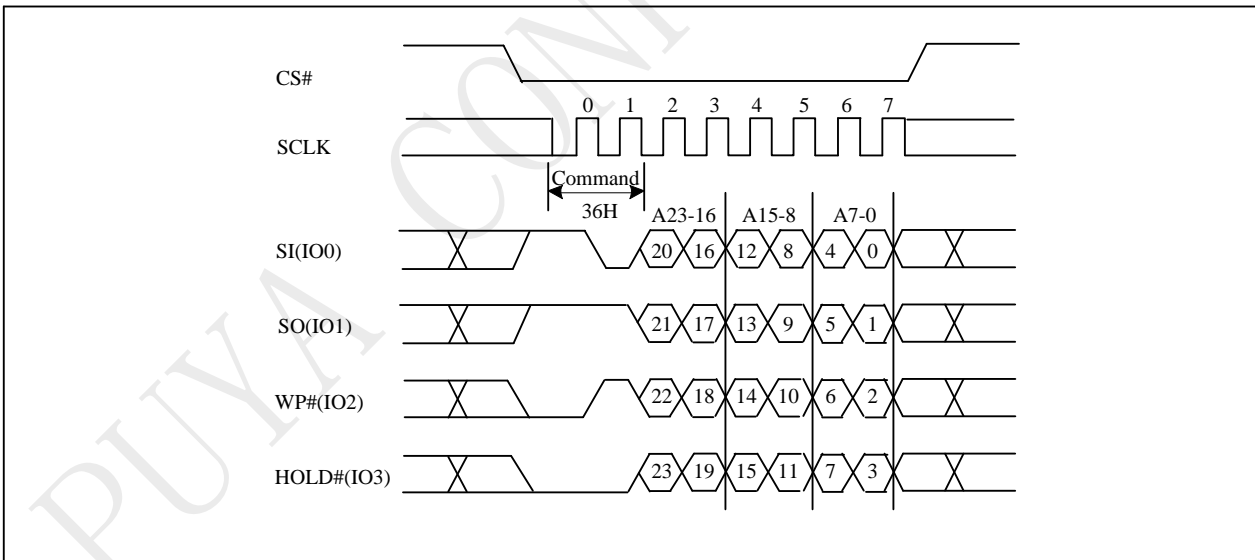

Note: 32-bit address is required when the device is operation in 4-byte address mode.

10.63 Individual Block Unlock (SBULK 39H)

The Individual Block Lock provides an alternative way to protect the memory array from adverse Erase/Program. In order to use the Individual Block Locks, the WPS bit in Configure Register must be set to 1. If WPS=0, the write protection will be determined by the combination of CMP, BP[4:0] bits in the Status Registers. The Individual Block Lock bits are volatile bits. The default values after device power up or after a Reset are 1, so the entire memory array is being protected.

The SBULK instruction will cancel the block (or sector) write protection state using AMAX-A16 or (AMAX-A12) address bits to assign a 64Kbyte block (or 4K bytes sector) to be unprotected. The WREN (Write Enable) instruction is required before issuing SBULK instruction.

The sequence of issuing SBULK instruction is: CS# goes low → send SBULK (39h) instruction → send 3/4-byte address assign one block (or sector) to be protected on SI pin → CS# goes high. The CS# must go high exactly at the byte boundary, otherwise the instruction will be rejected and not be executed.

Figure 10-63 Individual Block Unlock (Command 39H)

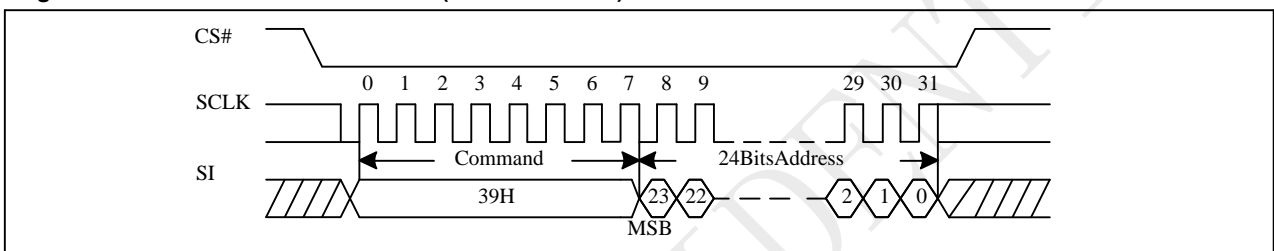

Note: 32-bit address is required when the device is operation in 4-byte address mode.

Figure 10-63a Individual Block Unlock (QPI)

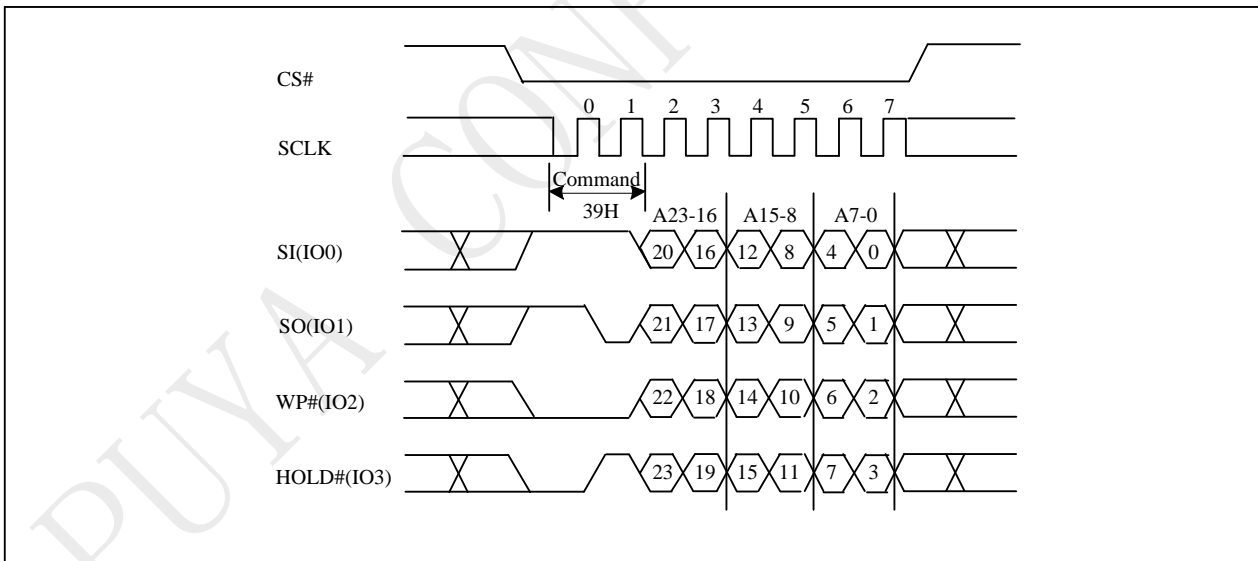

Note: 32-bit address is required when the device is operation in 4-byte address mode.

10.64 Read Block Lock Status (RDBLK 3DH)

The Individual Block Lock provides an alternative way to protect the memory array from adverse Erase/Program. In order to use the Individual Block Locks, the WPS bit in Configure Register must be set to 1. If WPS=0, the write protection will be determined by the combination of CMP, BP[4:0] bits in the Status Registers. The Individual Block Lock bits are volatile bits. The default values after device power up or after a Reset are 1, so the entire memory array is being protected.

The RDBLOCK instruction is for reading the status of protection lock of a specified block (or sector), using AMAX-A16 (or AMAX-A12) address bits to assign a 64K bytes block (4K bytes sector) and read protection lock status bit which the first byte of Read-out cycle. The status bit is "1" to indicate that this block has be protected, that user can read only but cannot write/program /erase this block. The status bit is "0" to indicate that this block hasn't be protected, and user can read and write this block.

The sequence of issuing RDBLOCK instruction is: CS# goes low → send RDBLOCK (3Dh) instruction → send 3/4-byte address to assign one block on SI pin → read block's protection lock status bit on SO pin → CS# goes high. Both SPI (8 clocks) and QPI (2 clocks) command cycle can accept by this instruction.

Figure 10-64 Read Block Lock Status (Command 3DH)

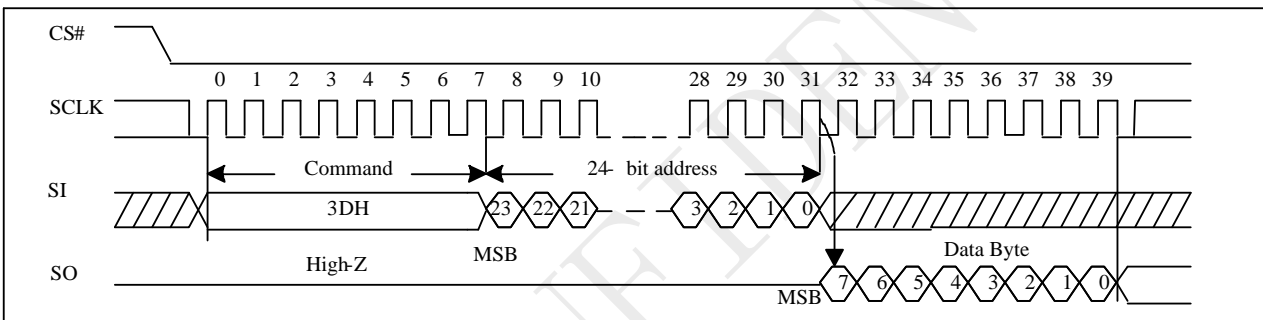

Note: 32-bit address is required when the device is operation in 4-byte address mode.

Figure 10-64a Read Block Lock Status (QPI)

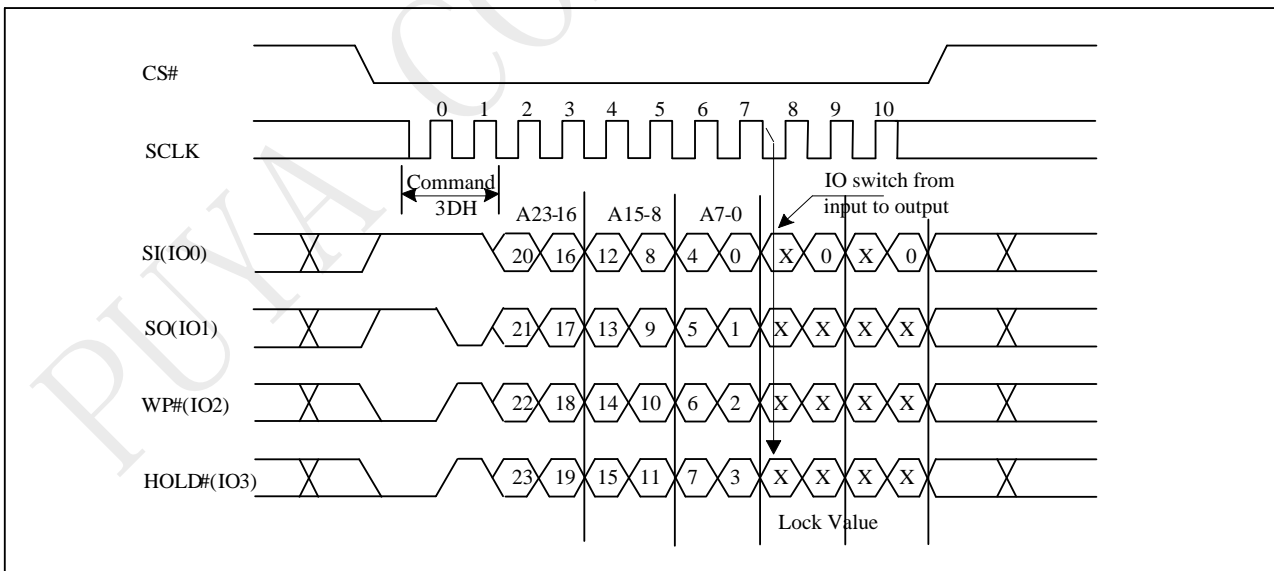

Note: 32-bit address is required when the device is operation in 4-byte address mode.

10.65 Global Block Lock (GBLK 7EH)

The GBLK instruction is for enable the lock protection block of the whole chip. The WREN (Write Enable) instruction is required before issuing GBLK instruction.

The sequence of issuing GBLK instruction is: CS# goes low → send GBLK (7EH) instruction → CS# goes high.

Both SPI (8 clocks) and QPI (2 clocks) command cycle can accept by this instruction. The SIO[3:1] are "don't care" in SPI mode. The CS# must go high exactly at the byte boundary, otherwise, the instruction will be rejected and not be executed.

Figure 10-65 Global Block Lock (Command 7EH)

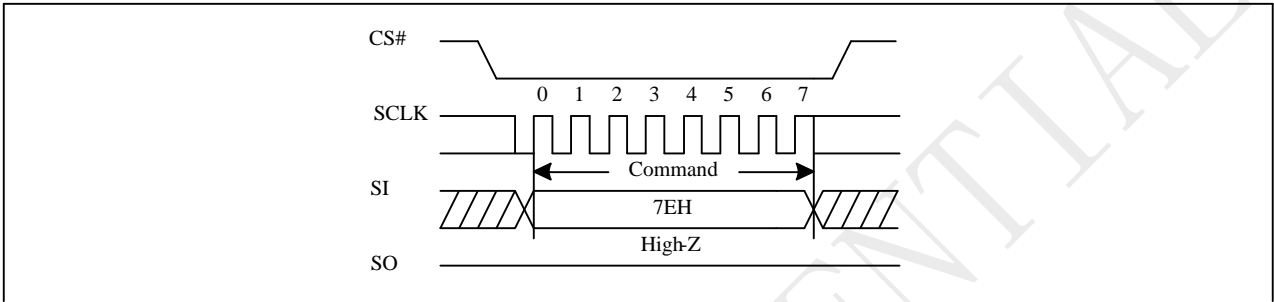
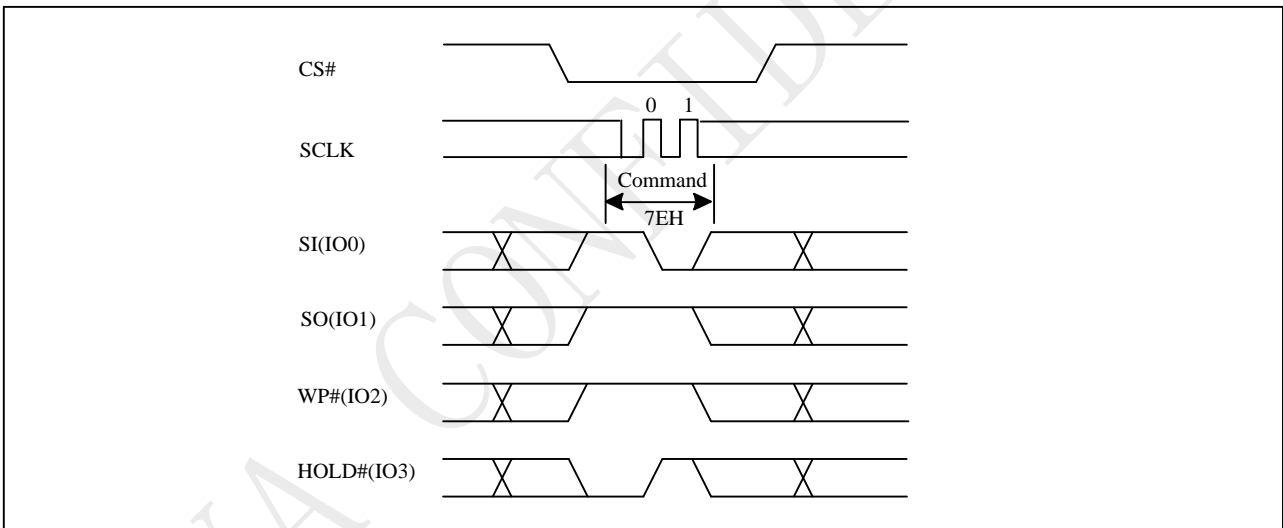

Figure 10-65a Global Block Lock (QPI)



10.66 Global Block Unlock (GBULK 98H)

The GBULK instruction is for disable the lock protection block of the whole chip. The WREN (Write Enable) instruction is required before issuing GBULK instruction.

The sequence of issuing GBULK instruction is: CS# goes low → send GBULK (98h) instruction → CS# goes high.

Both SPI (8 clocks) and QPI (2 clocks) command cycle can accept by this instruction. The SIO[3:1] are "don't care" in SPI mode. The CS# must go high exactly at the byte boundary, otherwise, the instruction will be rejected and not be executed.

Figure 10-66 Global Block Unlock (Command 98H)

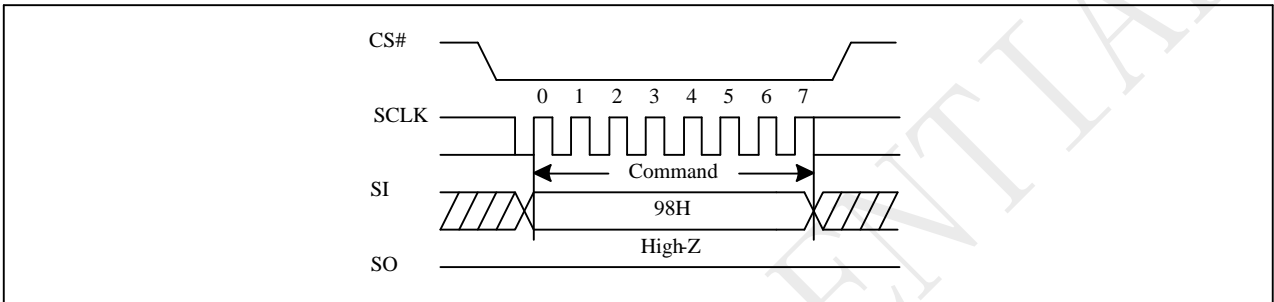
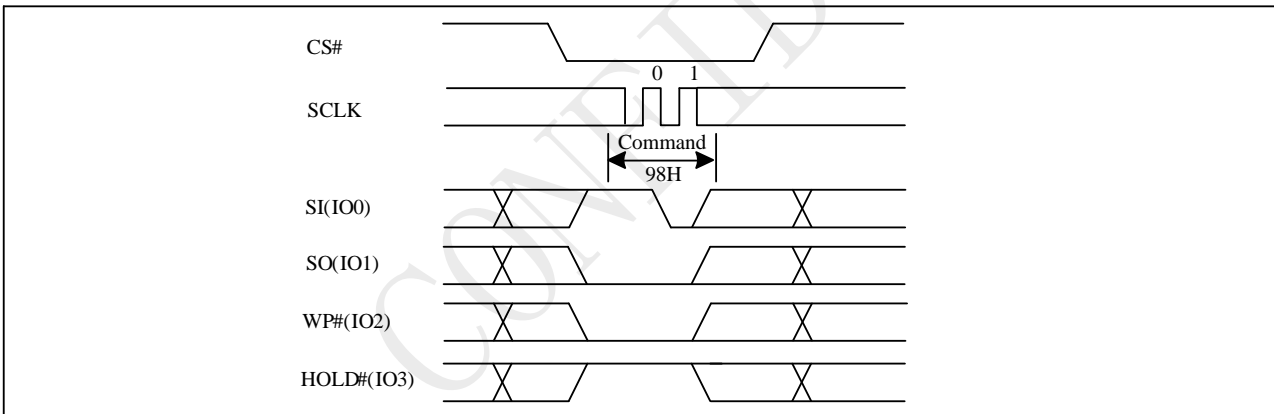

Figure 10-66a Global Block Unlock (QPI)



10.67 Software Reset (RSTEN/RST 66H/99H)

The Software Reset operation combines two instructions: Reset-Enable (RSTEN) command and Reset (RST) command. It returns the device to a standby mode. All the volatile bits and settings will be cleared then, which makes the device return to the default status as power on.

To execute Reset command (RST), the Reset-Enable (RSTEN) command must be executed first to perform the Reset operation. If there is any other command to interrupt after the Reset-Enable command, the Reset-Enable will be invalid. The SIO[3:1] are "don't care".

If the Reset command is executed during program or erase operation, the operation will be disabled, the data under processing could be damaged or lost.

Figure 10-67 Software Reset Recovery

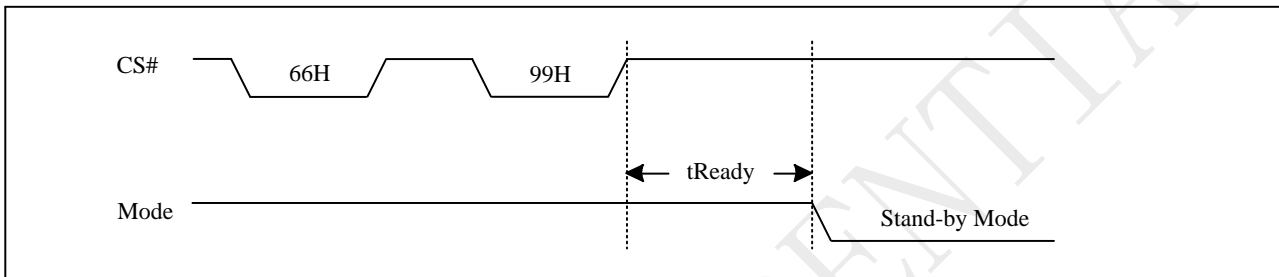

Figure 10-67a Reset Sequence

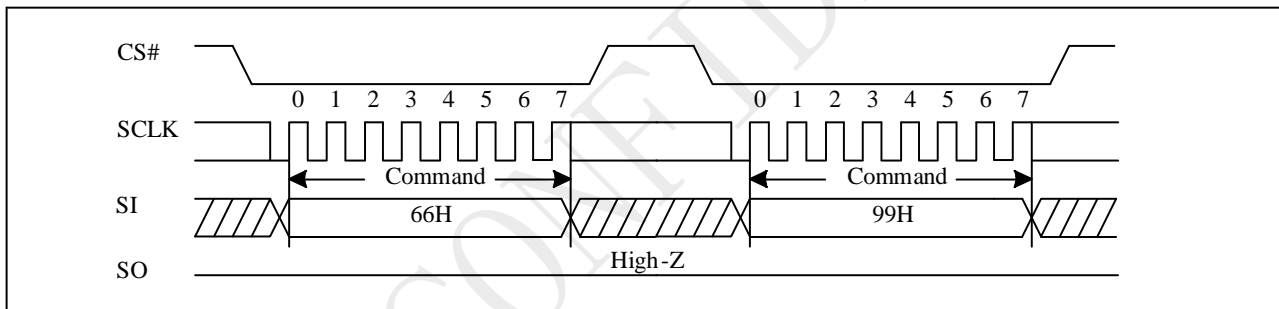
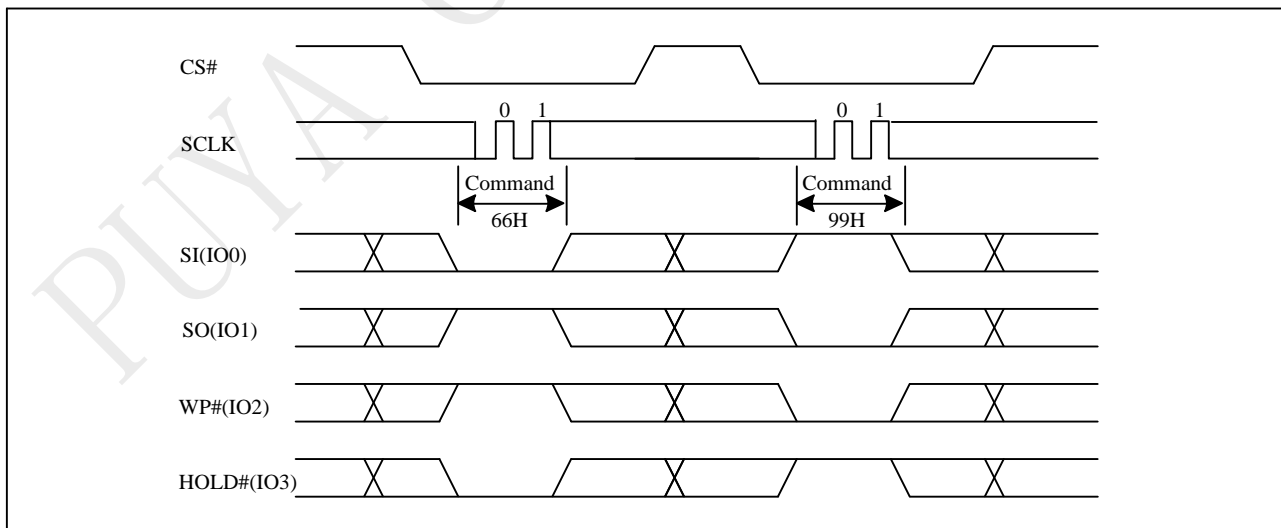

Figure 10-67b Reset Sequence (QPI)



10.68 RESET

Driving the HOLD#/RESET# (in RESET mode) pin or RESET# (for 16-pin package) pin low for a period of tRLRH or longer will reset the device. After reset cycle, the device is at the following states:

- Standby mode
- All the volatile bits such as WEL/WIP/SRAM lock bit will return to the default status as power on.

If the device is under programming or erasing, driving the RESET# pin low will also terminate the operation and data could be lost. During the resetting cycle, the SO data becomes high impedance and the current will be reduced to minimum.

Figure 10-68 RESET Timing

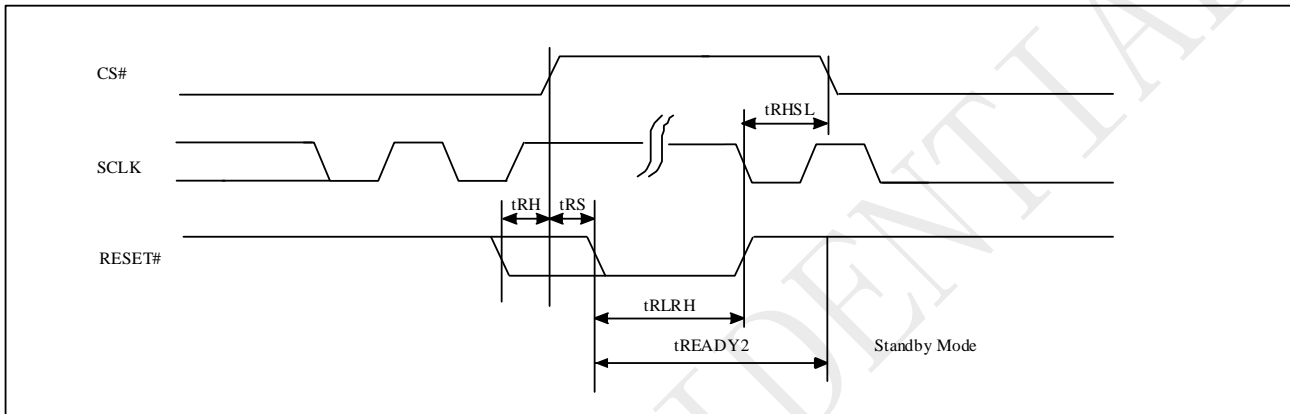

RESET Timing

Symbol	Parameter	Min	Typ ⁽²⁾	Max	Units
tRHSL	Reset# high before CS# low	1			us
tRS	Reset# setup time	15			ns
tRH	Reset# hold time	15			ns
tRLRH	Reset# low pulse width	1			us
tREADY2	Reset Recover time (Except erase/WRSR/WRSR1/WRCR)			30	us
	Reset Recover time (For WRSR/WRSR1/WRCR)		2 ⁽¹⁾	12	ms
	Reset Recover time (For erase operation)		5 ⁽¹⁾	12	ms

Note :

1. Suggest to add checking SR WIP Bit to make sure Reset flow finished.
2. Typical value at 3.0V @ 25°C.

10.69 Reset Signaling Protocol

The Reset Signaling Protocol is another method to issue reset function, which consists of two phases: reset request, and completion (a device internal reset).

Reset Request

1. CS# is driven active low to select the SPI target (Note1),
2. Clock (SCLK) remains stable in either a high or low state (Note 2),
3. SI / IO0 is driven low by the bus initiator, simultaneously with CS# going active low, (Note 3), and
4. CS# is driven inactive (Note 4).

Repeat the steps 1-4 each time alternating the state of SI (Note 5).

NOTE 1 This powers up the SPI target.

NOTE 2 This prevents any confusion with a command, as no command bits are transferred (clocked).

NOTE 3 No SPI bus target drives SI during CS# low before a transition of SCK, i.e., target streaming output active is not allowed until after the first edge of SCK.

NOTE 4 The target captures the state of SI on the rising edge of CS#.

NOTE 5 SI is low on the first CS#, high on the second, low on the third, high on the fourth (This provides a 5h pattern, to differentiate it from random noise).

Reset Completion

After the fourth CS# pulse, the target triggers its internal reset.

Figure 10-69 Timing Diagram and Timing Parameters

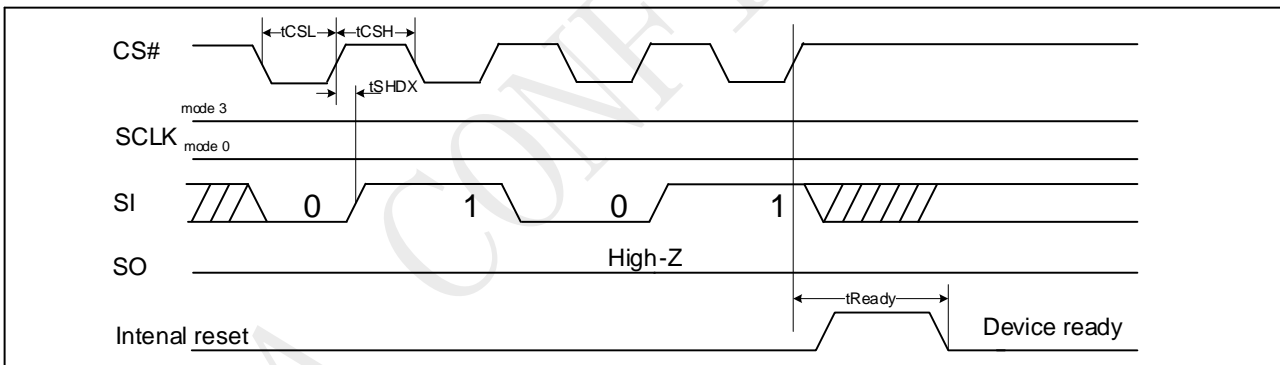

10.70 Read Unique ID (RUID 4BH)

The Read Unique ID command accesses a factory-set read-only 128bit number that is unique to each PY25Q512HB-Auto device. The Unique ID can be used in conjunction with user software methods to help prevent copying or cloning of a system.

The Read Unique ID command sequence: CS# goes low → sending Read Unique ID command → Dummy Byte1 → Dummy Byte2 → Dummy Byte3 → Dummy Byte4 → 128bit Unique ID Out → CS# goes high.

The command sequence is show below.

Figure 10-70 Read Unique ID (RUID) Sequence (Command 4BH)

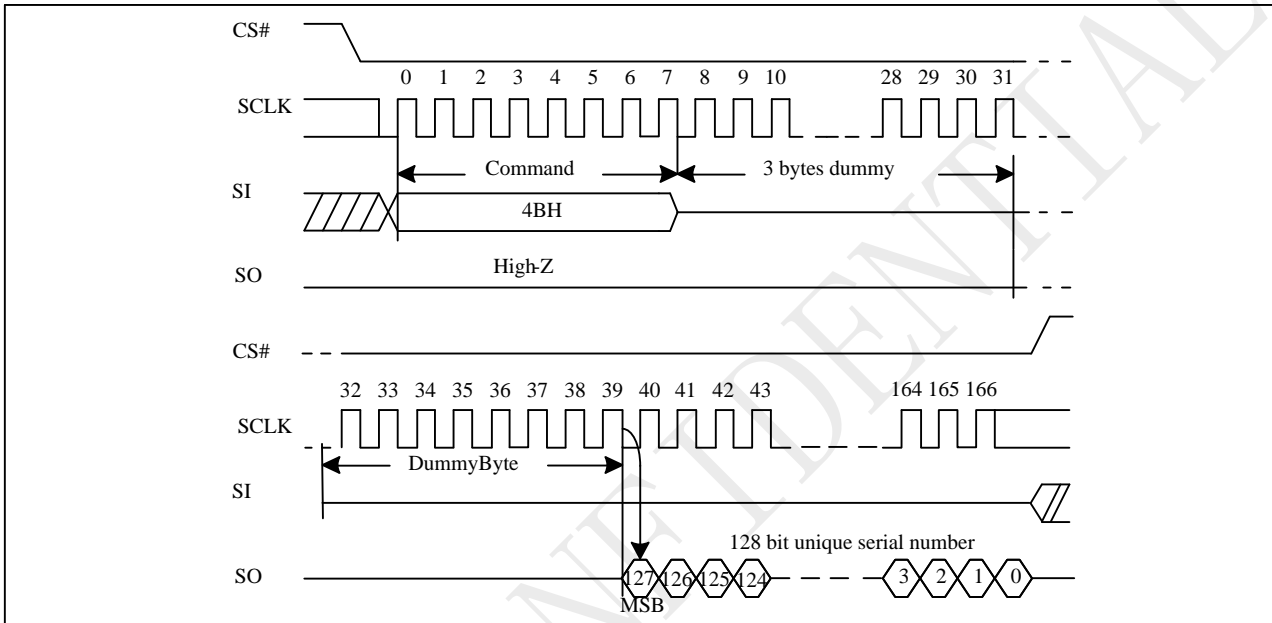

Note: 5 bytes dummy is required when the device is operation in 4-byte address mode.

Figure 10-70a Read Unique ID (RUID) Sequence (QPI 4BH)

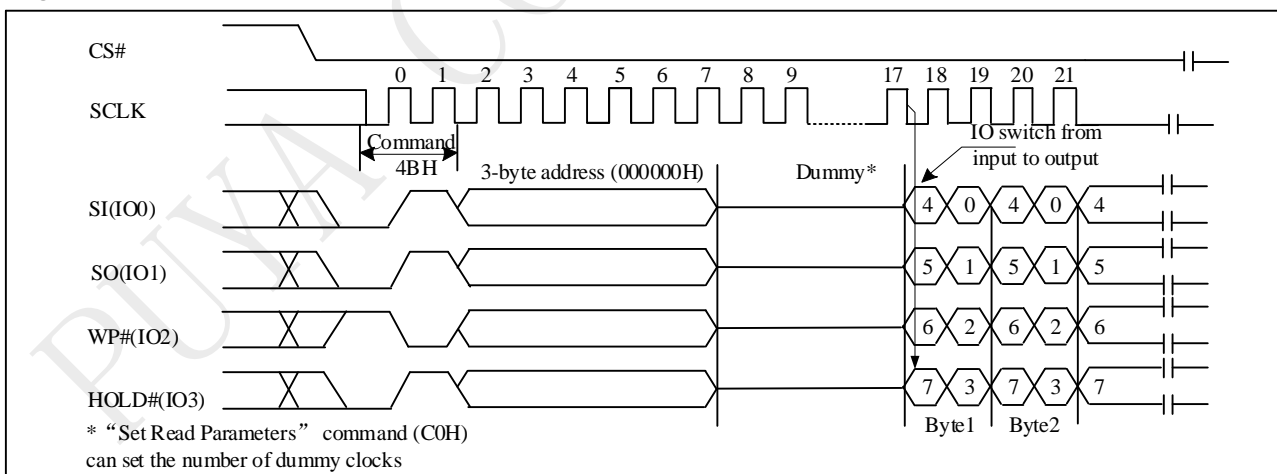

Note: 4 bytes address 0000_0000H is required when the device is operation in 4-byte address mode.

10.71 Read SFDP Mode (RDSFDP 5AH)

The Serial Flash Discoverable Parameter (SFDP) standard provides a consistent method of describing the functional and feature capabilities of serial flash devices in a standard set of internal parameter tables. These parameter tables can be interrogated by host system software to enable adjustments needed to accommodate divergent features from multiple vendors. The concept is similar to the one found in the Introduction of JEDEC Standard, JESD68 on CFI.

The sequence of issuing RDSFDP instruction is same as FREAD: CS# goes low → send RDSFDP instruction (5Ah) → send 3 address bytes on SI pin → send 1 dummy byte on SI pin → read SFDP code on SO → to end RDSFDP operation can use CS# to high at any time during data out.

SFDP is a JEDEC Standard, JESD216B.

Figure 10-71 Read Serial Flash Discoverable Parameter (RDSFDP) Sequence

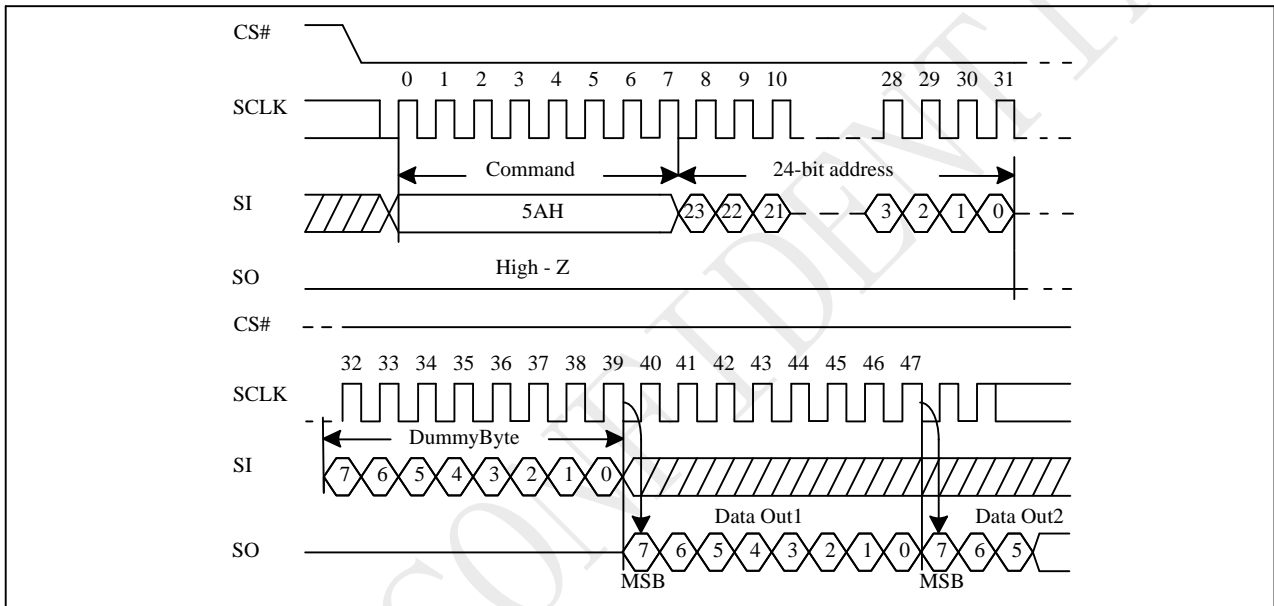
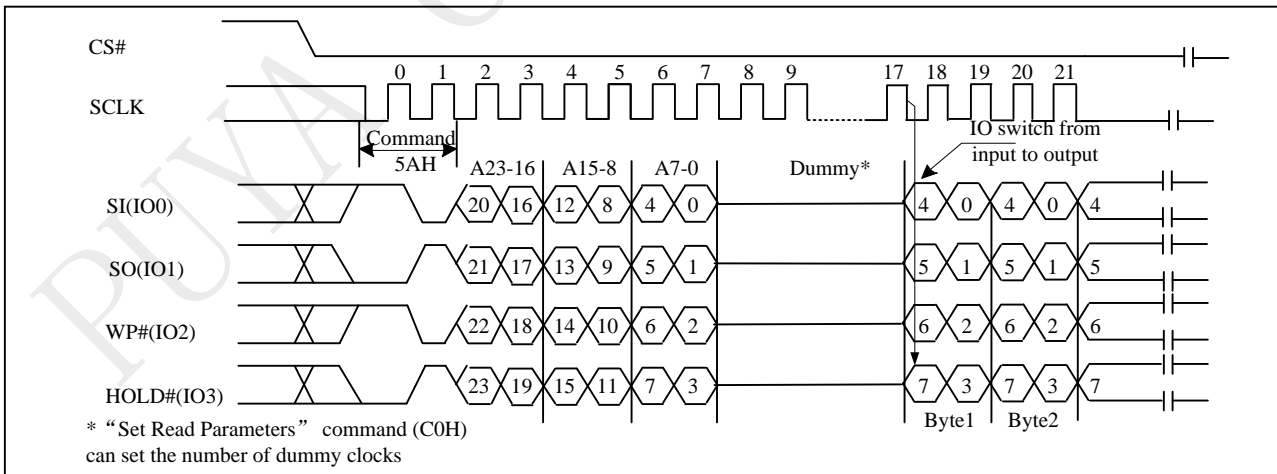

Figure 10-71a Read Serial Flash Discoverable Parameter (RDSFDP) Sequence (QPI)



* "Set Read Parameters" command (C0H) can set the number of dummy clocks

**Serial Flash Discoverable Parameter (SFDP) Table**

Table Signature and Parameter Identification Data Values

Description	Comment	Add(H) (Byte)	DW Add (Bit)	Data	Data
SFDP Signature	Fixed:50444653H	00H	07:00	53H	53H
		01H	15:08	46H	46H
		02H	23:16	44H	44H
		03H	31:24	50H	50H
SFDP Minor Revision Number	Start from 00H	04H	07:00	00H	00H
SFDP Major Revision Number	Start from 01H	05H	15:08	01H	01H
Number of Parameters Headers	Start from 00H	06H	23:16	01H	01H
Unused	Contains 0xFFH and can never be changed	07H	31:24	FFH	FFH
ID number (JEDEC)	00H: It indicates a JEDEC specified header	08H	07:00	00H	00H
Parameter Table Minor Revision Number	Start from 0x00H	09H	15:08	00H	00H
Parameter Table Major Revision Number	Start from 0x01H	0AH	23:16	01H	01H
Parameter Table Length (in double word)	How many DWORDs in the Parameter table	0BH	31:24	09H	09H
Parameter Table Pointer (PTP)	First address of JEDEC Flash Parameter table	0CH	07:00	30H	30H
		0DH	15:08	00H	00H
		0EH	23:16	00H	00H
Unused	Contains 0xFFH and can never be changed	0FH	31:24	FFH	FFH
ID Number (PUYA Device Manufacturer ID)	It indicates PUYA manufacturer ID	10H	07:00	85H	85H
Parameter Table Minor Revision Number	Start from 0x00H	11H	15:08	00H	00H
Parameter Table Major Revision Number	Start from 0x01H	12H	23:16	01H	01H
Parameter Table Length (in double word)	How many DWORDs in the Parameter table	13H	31:24	03H	03H
Parameter Table Pointer (PTP)	First address of PUYA Flash Parameter table	14H	07:00	60H	60H
		15H	15:08	00H	00H
		16H	23:16	00H	00H
Unused	Contains 0xFFH and can never be changed	17H	31:24	FFH	FFH



Table Parameter Table (0): JEDEC Flash Parameter Tables

Description	Comment	Add(H) (Byte)	DW Add (Bit)	Data	Data
Block/Sector Erase Size	00: Reserved; 01: 4KB erase; 10: Reserved; 11: not support 4KB erase	30H	01:00	01b	ESH
Write Granularity	0: 1Byte, 1: 64Byte or larger		02	1b	
Write Enable Instruction Requested for Writing to Volatile Status Registers	0: Nonvolatile status bit 1: Volatile status bit (BP status register bit)		03	0b	
Write Enable Opcode Select for Writing to Volatile Status Registers	0: Use 50H Opcode, 1: Use 06H Opcode, Note: If target flash status register is Nonvolatile, then bits3 and 4 must be set to 00b.		04	0b	
Unused	Contains 111b and can never be changed		07:05	111b	
4KB Erase Opcode		31H	15:08	20H	20H
(1-1- 2) Fast Read	0=Not support, 1=Support	32H	16	1b	FBH
Address Bytes Number used in addressing flash array	00: 3Byte only, 01: 3 or 4Byte, 10: 4Byte only, 11: Reserved		18:17	01b	
Double Transfer Rate (DTR) clocking	0=Not support, 1=Support		19	1b	
(1-2- 2) FastRead	0=Not support, 1=Support		20	1b	
(1-4- 4) Fast Read	0=Not support, 1=Support		21	1b	
(1-1- 4) Fast Read	0=Not support, 1=Support		22	1b	
Unused			23	1b	
Unused		33H	31:24	FFH	FFH
Flash Memory Density		37H:34H	31:00	1FFFFFFFH	
(1-4- 4) Fast Read Number of Wait states	0 0000b: Wait states (Dummy Clocks) not support	38H	04:00	00100b	44H
(1-4- 4) Fast Read Number of Mode Bits	000b:Mode Bits not support		07:05	010b	
(1-4- 4) Fast Read Opcode		39H	15:08	EBH	EBH
(1-1- 4) Fast Read Number of Wait states	0 0000b: Wait states (Dummy Clocks) not support	3AH	20:16	01000b	08H
(1-1- 4) Fast Read Number of Mode Bits	000b:Mode Bits not support		23:21	000b	
(1-1- 4) Fast Read Opcode		3BH	31:24	6BH	6BH



Description	Comment	Add(H) (Byte)	DW Add (Bit)	Data	Data
(1-1-2) Fast Read Number of Wait states	0 0000b: Wait states (Dummy Clocks) not support	3CH	04:00	01000b	08H
(1-1- 2) Fast Read Number of Mode Bits	000b: Mode Bits not support		07:05	000b	
(1-1- 2) Fast Read Opcode		3DH	15:08	3BH	3BH
(1-2- 2) Fast Read Number of Wait states	0 0000b: Wait states (Dummy Clocks) not support	3EH	20:16	00000b	80H
(1-2- 2) Fast Read Number of Mode Bits	000b: Mode Bits not support		23:21	100b	
(1-2- 2) Fast Read Opcode		3FH	31:24	BBH	BBH
(2-2- 2) Fast Read	0=not support 1=support	40H	00	0b	EEH
Unused			03:01	111b	
(4-4- 4) Fast Read	0=not support 1=support		04	0b	
Unused			07:05	111b	
Unused		43H:41H	31:08	0xFFH	0xFFH
Unused		45H:44H	15:00	0xFFH	0xFFH
(2-2-2) Fast Read Number of Wait states	0 0000b: Wait states (Dummy Clocks) not support	46H	20:16	00000b	00H
(2-2- 2) Fast Read Number of Mode Bits	000b: Mode Bits not support		23:21	000b	
(2-2- 2) Fast Read Opcode		47H	31:24	FFH	FFH
Unused		49H:48H	15:00	0xFFH	0xFFH
(4-4-4) Fast Read Number of Wait states	0 0000b: Wait states (Dummy Clocks) not support	4AH	20:16	00000b	00H
(4-4- 4) Fast Read Number of Mode Bits	000b: Mode Bits not support		23:21	000b	
(4-4- 4) Fast Read Opcode		4BH	31:24	FFH	FFH
Sector Type 1 Size	Sector/block size=2 ^N bytes 0x00b: this sector type don't exist	4CH	07:00	0CH	0CH
Sector Type 1 erase Opcode		4DH	15:08	20H	20H
Sector Type 2 Size	Sector/block size=2 ^N bytes 0x00b: this sector type don't exist	4EH	23:16	0FH	0FH
Sector Type 2 erase Opcode		4FH	31:24	52H	52H
Sector Type 3 Size	Sector/block size=2 ^N bytes 0x00b: this sector type don't exist	50H	07:00	10H	10H
Sector Type 3 erase Opcode		51H	15:08	D8H	D8H
Sector Type 4 Size	Sector/block size=2 ^N bytes 0x00b: this sector type don't exist	52H	23:16	00H	00H
Sector Type 4 erase Opcode		53H	31:24	FFH	FFH



Table Parameter Table (1): PUYA Flash Parameter Tables

Description	Comment	Add(H) (Byte)	DW Add (Bit)	Data	Data
Vcc Supply Maximum Voltage	2000H=2.000V 2700H=2.700V 3600H=3.600V	61H:60H	15:00	3600H	3600H
Vcc Supply Minimum Voltage	1650H=1.650V 2250H=2.250V 2350H=2.350V 2700H=2.700V	63H:62H	31:16	2700H	2700H
HW Reset# pin	0=not support 1=support	65H:64H	00	0b	F99EH
HW Hold# pin	0=not support 1=support		01	1b	
Deep Power Down Mode	0=not support 1=support		02	1b	
SW Reset	0=not support 1=support		03	1b	
SW Reset Opcode	Should be issue Reset Enable(66H) before Reset cmd.		11:04	1001 1001b (99H)	
Program Suspend/Resume	0=not support 1=support		12	1b	
Erase Suspend/Resume	0=not support 1=support		13	1b	
Unused			14	1b	
Wrap Around Read mode	0=not support 1=support		15	1b	
Wrap - Around Read mode Opcode			66H	23:16	
Wrap - Around Read data length	08H:support 8B wraparound read 16H:8B&16B 32H:8B&16B&32B 64H:8B&16B&32B&64B	67H	31:24	64H	64H
Individual block lock	0=not support 1=support	6BH:68H	00	1b	C8D9H
Individual block lock bit (Volatile/Nonvolatile)	0=Volatile 1=Nonvolatile		01	0b	
Individual block lock Opcode			09:02	36H	
Individual blocklock Volatile protect bit default protect status	0=protect 1=unprotect		10	0b	
Secured OTP	0=not support 1=support		11	1b	
Read Lock	0=not support 1=support		12	0b	
Permanent Lock	0=not support 1=support		13	0b	
Unused			15:14	11b	
Unused			31:16	FFFFH	



11 Ordering Information

PY 25 Q 512 H B - S M H - A T

Company Designator

PY= Puya Semiconductor

Product Family

25 = SPI interface flash

Product Serial

Q = Q serial

Memory Density

512 = 512Mb

Operation Voltage

H = 2.7V~3.6V

Generation

B = Gen. B

Package Type

SM = SOP16 300mil

WZ = WSON8 8x6x0.75mm

TF = 24-ball TFBGA 6x8(5x5 Array)

WF = WAFER

Plating Technology

H: RoHS Compliant, Halogen free, Antimony free

Device Grade

H = Automotive Grade 2 , -40C ~ 105C

A = Automotive Grade 1 , -40C ~ 125C

Packing Type

T = TUBE

R = TAPE & REEL

Y = TRAY

W = WAFER



12 Valid Part Numbers and Top Marking

The following table provides the valid part numbers for the PY25Q512HB-Auto Flash Memory. Please contact PUYA for specific availability by density and package type. PUYA Flash memories use a 15-digit Product Number for ordering.

Package Type	Product Number	Density	Top Side Marking	Temp.	Packing Type
SM SOP16 300mil	PY25Q512HB-SMH-HT	512M-bit	PY25Q512HB xxxxxxx	105C	Tube
SM SOP16 300mil	PY25Q512HB-SMH-HR	512M-bit	PY25Q512HB xxxxxxx	105C	Reel
WZ WSO8 8x6mm	PY25Q512HB-WZH-HR	512M-bit	PY25Q512HB xxxxxxx	105C	Reel
TF TFBGA 24-Ball 6x8mm	PY25Q512HB-TFH-HR	512M-bit	PY25Q512HB xxxxxxx	105C	Reel
SM SOP16 300mil	PY25Q512HB-SMH-AT	512M-bit	PY25Q512HB xxxxxxx	125C	Tube
SM SOP16 300mil	PY25Q512HB-SMH-AR	512M-bit	PY25Q512HB xxxxxxx	125C	Reel
WZ WSO8 8x6mm	PY25Q512HB-WZH-AR	512M-bit	PY25Q512HB xxxxxxx	125C	Reel
TF TFBGA 24-Ball 6x8mm	PY25Q512HB-TFH-AR	512M-bit	PY25Q512HB xxxxxxx	125C	Reel

13 Package Information

13.1 8-Pad WSON(8x6x0.75mm)

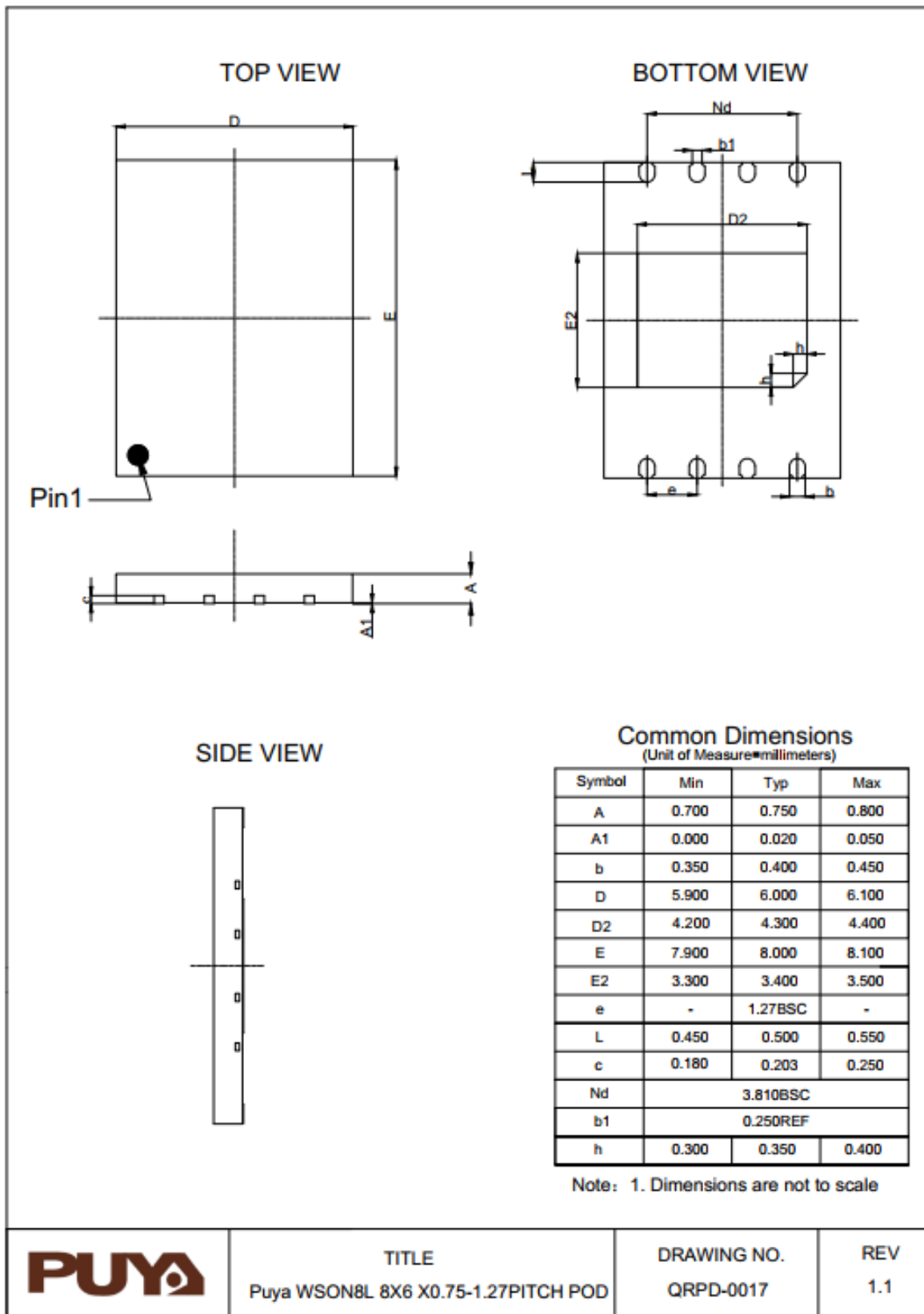



13.2 16-Lead SOP (300mil)

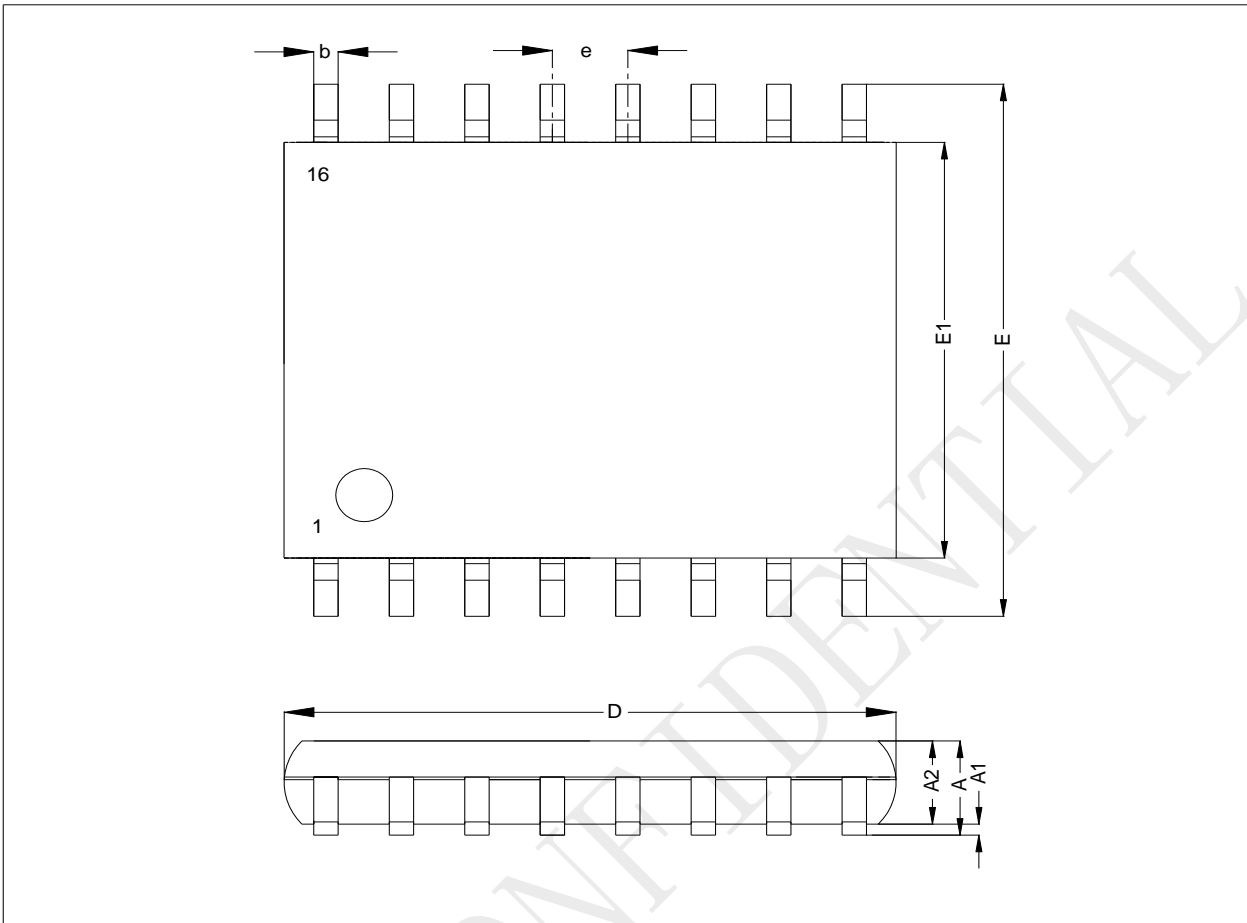

Common Dimensions
(Unit of Measure=millimeters)

Symbol	Min	Typ	Max
A	-	-	2.65
A1	0.10	-	0.30
A2	-	2.30	-
b	0.33	-	0.51
c	0.23	-	0.32
D	10.10	-	10.50
E	10.00	-	10.65
E1	7.40	-	7.60
e	1.27BSC		
L	0.40	-	1.27
θ	0	-	8°

Note: Dimensions are not to scale.

	TITLE PUYA SOP16 (300mil) POD	DRAWING NO. QRPD-0055	REV 1.0
--	----------------------------------	--------------------------	------------

13.3 24-Ball TFBGA

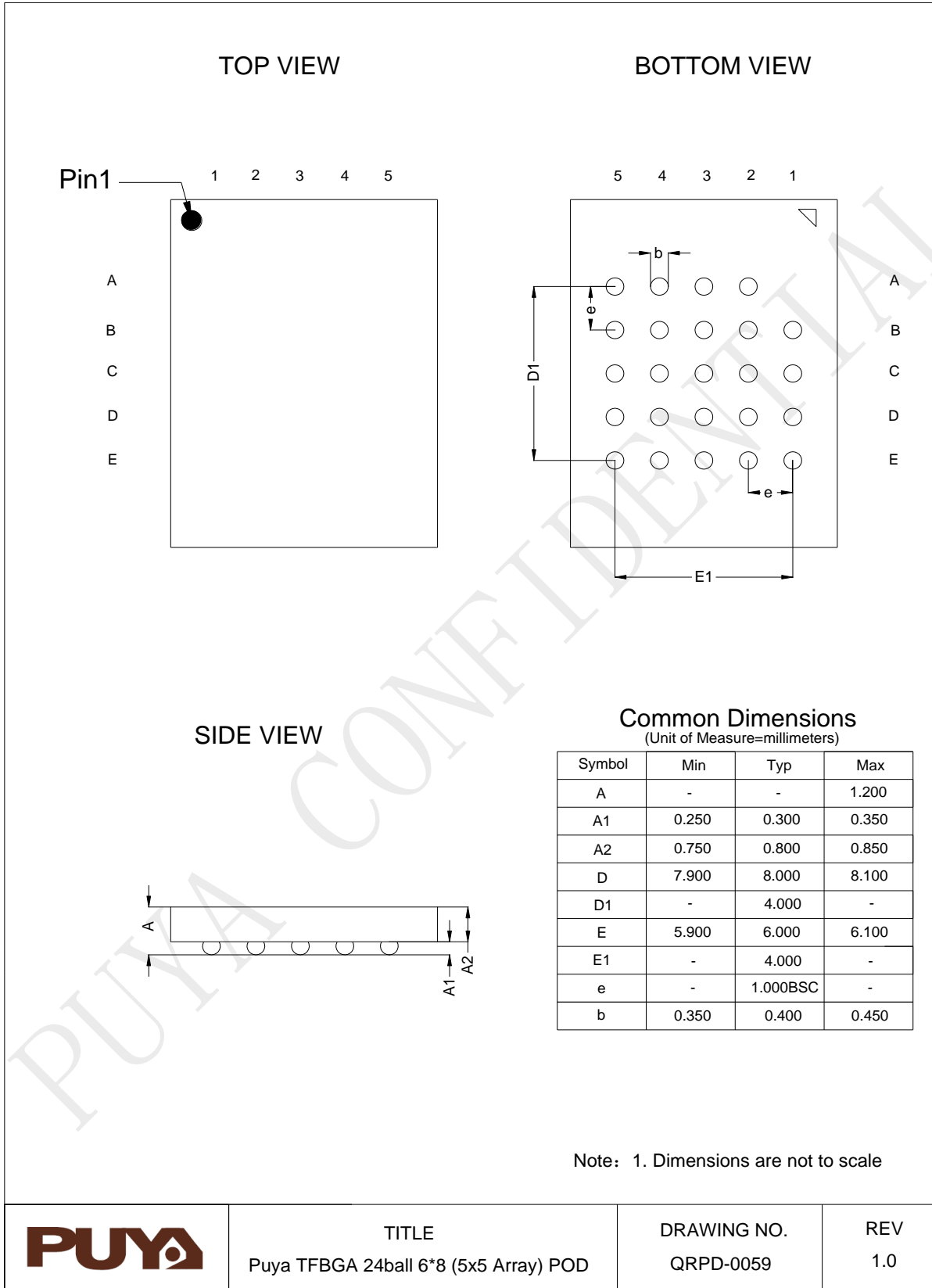



14 Revision History

Rev.	Date	Description	Note
1.0	2024-3-15	Initial release	-

CONFIDENTIAL

IMPORTANT NOTICE

Puya reserve the right to make changes, corrections, enhancements, modifications to Puya products and/or to this document at any time without notice. Purchasers should obtain the latest relevant information of Puya products before placing orders.

Puya products are sold pursuant to terms and conditions of sale in place at the time of order acknowledgement.

Purchasers are solely responsible for the choice and use of Puya products. Puya does not provide service support and assumes no responsibility when products that are used on its own or designated third party products.

Puya hereby disclaims any license to any intellectual property rights, express or implied.

Resale of Puya products with provisions inconsistent with the information set forth herein shall void any warranty granted by Puya.

Any with Puya or Puya logo are trademarks of Puya. All other product or service names are the property of their respective owners.

The information in this document supersedes and replaces the information in the previous version.

Puya Semiconductor Co., Ltd. – All rights reserved