

Silicon Variable Capacitance Diode

- For VHF-TV-tuners
- High capacitance ratio
- Low series inductance
- Low series resistance
- Extremely small plastic SMD package
- Excellent uniformity and matching due to "in-line" matching assembly procedure

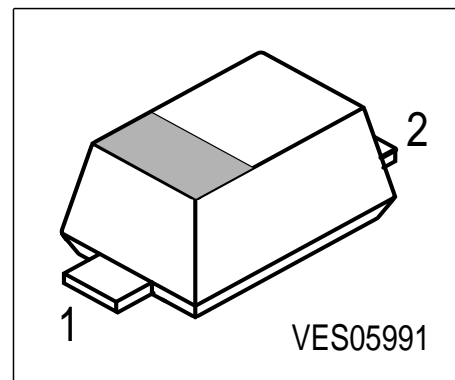

Type	Marking	Ordering Code	Pin Configuration		Package
BB 659C	H	Q62702-B0884 inline matched	1 = C	2 = A	SCD-80
BB 659C	H	Q62702-B0880 unmatched			

Maximum Ratings

Parameter	Symbol	Value	Unit
Diode reverse voltage	V_R	30	V
Peak reverse voltage ($R \geq 5k\Omega$)	V_{RM}	35	
Forward current	I_F	20	mA
Operating temperature range	T_{op}	- 55 ...+150	°C
Storage temperature	T_{stg}	- 55 ...+150	

Electrical Characteristics at $T_A = 25^\circ\text{C}$, unless otherwise specified.

Parameter	Symbol	Values			Unit
		min.	typ.	max.	
DC characteristics					
Reverse current $V_R = 30\text{ V}$	I_R	-	-	10	nA
Reverse current $V_R = 30\text{ V}, T_A = 85^\circ\text{C}$	I_R	-	-	200	
AC characteristics					
Diode capacitance $V_R = 1\text{ V}, f = 1\text{ MHz}$ $V_R = 2\text{ V}, f = 1\text{ MHz}$ $V_R = 25\text{ V}, f = 1\text{ MHz}$ $V_R = 28\text{ V}, f = 1\text{ MHz}$	C_T	36 27 2.5 2.4	39 30.2 2.72 2.55	42 33.2 3.05 2.8	pF
Capacitance ratio $V_R = 2\text{ V}, V_R = 25\text{ V}, f = 1\text{ MHz}$	C_{T2}/C_{T25}	9.5	11.1	-	-
Capacitance ratio $V_R = 1\text{ V}, V_R = 28\text{ V}, f = 1\text{ MHz}$	C_{T1}/C_{T28}	13.5	15.3	-	
Capacitance matching ¹⁾ $V_R = 1\text{V to } 28\text{V}, f = 1\text{ MHz}, 4\text{ diodes sequence}$ $V_R = 1\text{V to } 28\text{V}, f = 1\text{ MHz}, 7\text{ diodes sequence}$	$\Delta C_T/C_T$	- -	0.3 0.5	1 2	%
Series resistance $V_R = 1\text{ V}, f = 1\text{ GHz}$	r_s	-	0.6	0.7	Ω
Series inductance	L_s	-	0.6	-	nH

1) In-line matching. For details please refer to Application Note 047

Diode capacitance $C_T = f(V_R)$

$f = 1\text{MHz}$

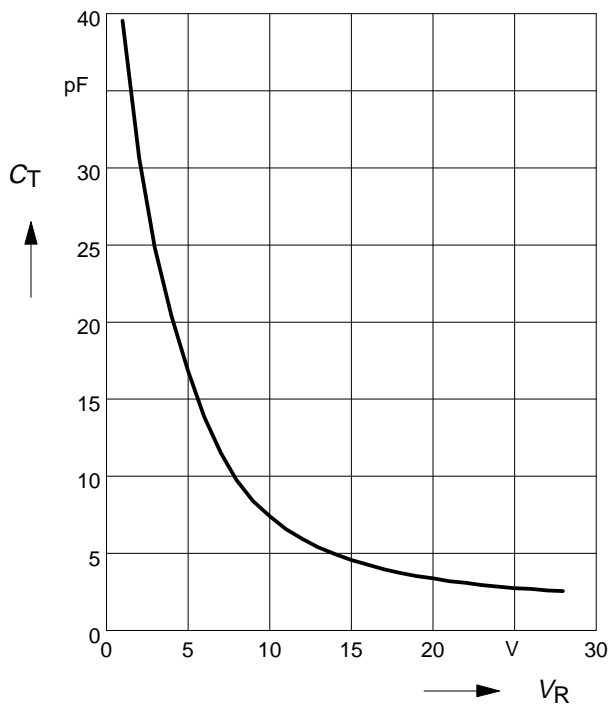

Temperature coefficient of the diode capacitance $T_{Cc} = f(V_R)$

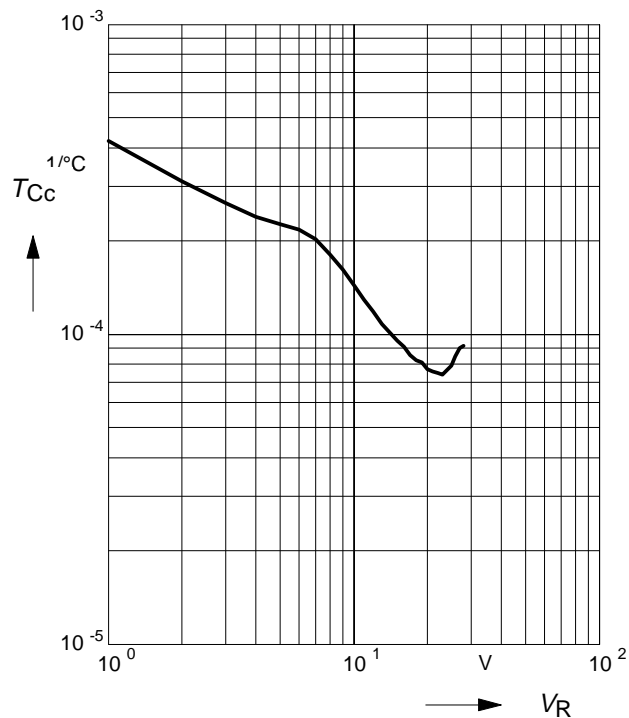

Reverse current $I_R = f(V_R)$

$T_A = \text{Parameter}$

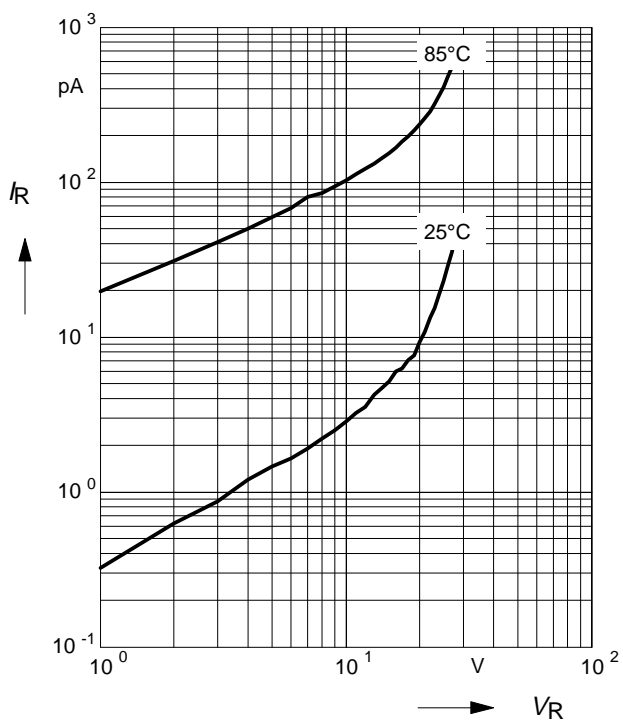

Reverse current $I_R = f(T_A)$

$V_R = 28\text{V}$

