

Q-Flex[®] QA-700 Accelerometer

Economical temperature-compensated sensor

For Q-Flex technology in an economical temperature-compensated package, Honeywell produces the QA700 for a broad array of moderate performance applications, including: flight and flight simulator control systems, radar platform leveling, high-speed train ride control, and seismic sensing.

As with the entire Q-Flex family of accelerometers, the QA700 features a patented Q-Flex etched-quartz-flexure seismic system. An amorphous quartz proof-mass structure provides excellent bias, scale factor, and axis alignment stability.

The integral electronics develops an acceleration-proportional output current providing both static and dynamic acceleration measurements. By use of a customer supplied output load resistor, appropriately scaled for the acceleration range of the application, the output current can be converted into a voltage.



As an option, the QA700 can be provided with a temperature-compensating algorithm where bias, scale factor, and axis misalignment performance are dramatically improved.

Features

- Tactical navigation grade performance
- High value
- Environmentally rugged
- Analog output
- Compact design
- Field-adjustable range
- Dual built-in test
- Optional thermal compensation

Configuration Drawings

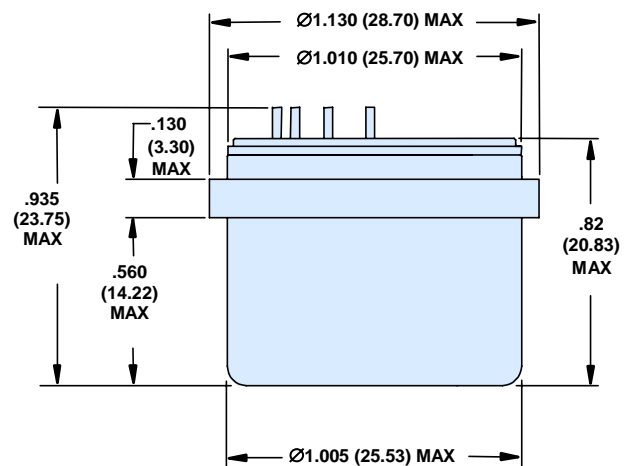
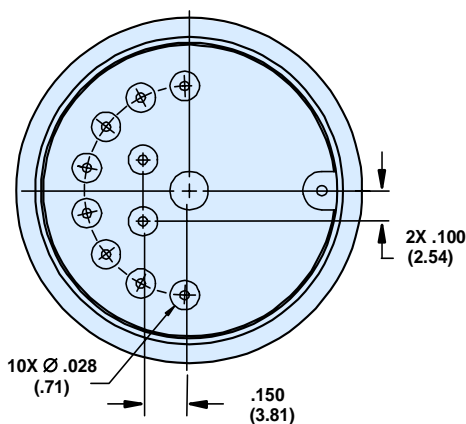

Performance Characteristics

Additional product specifications, outline drawings and block diagrams, and test data are available on request.

Performance	
Input Range [g]	±30
Bias [mg]	<8
One-year Composite Repeatability [µg]	<1200
Temperature Sensitivity [µg/°C]	<70
Scale Factor [mA/g]	1.23 to 1.43
One-year Composite Repeatability [ppm]	<1200
Temperature Sensitivity [ppm/°C]	<200
Axis Misalignment [µrad]	<2000
Vibration Rectification [µg/g ² rms]	<50 (50-200 Hz) <100 (200-750 Hz) <150 (750-2000 Hz)
Intrinsic Noise [µg-rms]	<7 (0-10 Hz) <70 (10-500 Hz) <1500 (500-10,000 Hz)
Environment	
Operating Temperature Range [°C]	-55 to +96
Shock [g]	250
Vibration Peak Sine [g]	25 @ 20-2000 Hz
Resolution/Threshold [µg]	<1
Bandwidth [Hz]	>300
Thermal Modeling	
	-010 NO -020 YES
Electrical	
Quiescent Current per Supply [mA]	<16
Quiescent Power [mW] @ ±15 VDC	<480
Electrical Interface	Temp Sensor Voltage Self Test Current Self Test Power / Signal Ground -10 VDC Output +10 VDC Output
Input Voltage	±13 to±18
Physical	
Weight [grams]	46 Nominal, 50 Max.
Diameter below mounting surface [inches]	Ø1.07 ±0.01
Height - bottom to mounting surface [inches]	.600 Max
Case Material	300 Series Stainless Steel

Find out more:

www.inertialsensor.com

Defense & Space Redmond

Honeywell International, Inc.

MAIL ADDRESS: P.O. Box 97001

15001 N.E. 36th Street

Redmond, Washington 98073-9701

PHONE: 888 206 1667

FAX: 425 883 2104

www.honeywell.com

EXP025, August 2005

Copyright © 2004, Honeywell International Inc. All Rights Reserved. Printed in USA

ISO-9001 Certification Since 1995

DISCLAIMER: Specifications are subject to change without notice. Honeywell reserves the right to make changes to any product or technology herein to improve reliability, function, or design. Honeywell does not assume any liability arising out of the application or use of the product.

Accelerometers exported from the United States must be done in accordance with the Export Administration Regulations (EAR) and/or the International Traffic in Arms Regulations (ITAR) as applicable.

Honeywell