

R.F. POWER TETRODE



Products approved to CECC 45 003-007

QUICK REFERENCE DATA

λ	freq.	C telegr.		B teleph.		C _{ag2} mod.*		B mod.*	
		V _a V	W _o W	V _a V	W _o W	V _a V	W _o W	V _a V	W _o W
> 4	< 75	4000 3000 2500	1000 800 575	4000 3000 2500	126 125 125	3000 2500	510 375	3000 2500 2000 1500	1240 1140 974 660
2,5	120	2500	500						

HEATING: direct; filament thoriated tungsten

Filament voltage	V _f	=	5 V
Filament current	I _f	=	14,1 A

COOLING: radiation/low-velocity air flow

CAPACITANCES

Anode to all other elements except grid 1	C _a	=	4,5 pF
Grid 1 to all other elements except anode	C _{g1}	=	12,7 pF
Anode to grid 1	C _{ag1}	=	0,12 pF

TYPICAL CHARACTERISTICS

Amplification factor of grid 2 with respect to grid 1	μ_{g2g1}	=	5,1
Mutual conductance	S (I _a = 100 mA)	=	4 mA/V

* Two tubes; I_{G1} > 0.

TEMPERATURE LIMITS

Absolute maximum rating system

Temperature of anode seal	max.	220 °C
Temperature of pin seals	max.	180 °C
Bulb temperature	max.	350 °C

COOLING

In order to keep the temperatures below the maximum permitted values a low-velocity air flow has to be directed to the anode seal and the bottom of the envelope.

In order to prevent overheating of the screen-grid pins by high-frequency current it is recommended that both screen-grid socket connections be included in the circuit.

MECHANICAL DATA

Base	giant 5 p
Socket	2422 512 01001
Anode connector	40712
Net mass	185 g

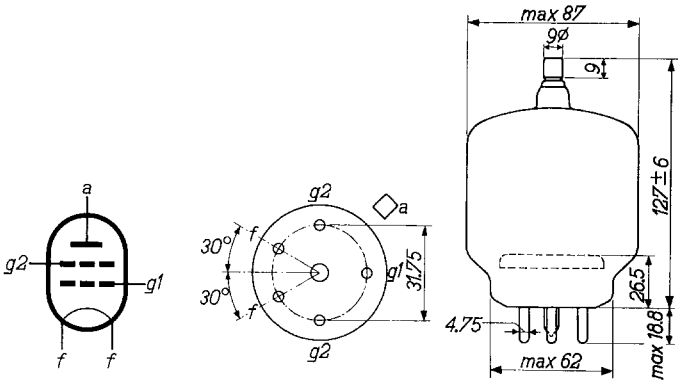

Mounting position vertical with base up or down

R.F. CLASS C TELEGRAPHY

LIMITING VALUES (Absolute limits)

Frequency	f	up to 75	up to 100	up to 120	MHz
Anode voltage	V_a	= max. 4000	max. 3300	max. 2500	V
Anode input power	W_{ia}	= max. 1250	max. 1000	max. 750	W
Anode dissipation	W_a	=	max. 250		W
Anode current	I_a	=	max. 350		mA
Grid No.2 voltage	V_{g2}	=	max. 600		V
Grid No.2 dissipation	W_{g2}	=	max. 35		W
Negative grid No.1 voltage	$-V_{g1}$	=	max. 500		V
Grid No.1 current	I_{g1}	=	max. 20		mA

OPERATING CONDITIONS

Frequency	f	=	75	75	75	MHz
Anode voltage	V_a	=	4000	3000	2500	V
Grid No.2 voltage	V_{g2}	=	500	500	500	V
Grid No.1 voltage	V_{g1}	=	-225	-180	-150	V
Anode current	I_a	=	312	345	300	mA
Grid No.2 current	I_{g2}	=	45	60	60	mA
Grid No.1 current	I_{g1}	=	9	10	9	mA
Peak grid No.1 A.C. voltage	V_{g1p}	=	303	265	220	V
Grid No.1 input power	W_{ig1}	=	2.5	2.4	1.8	W
Grid No.2 dissipation	W_{g2}	=	22.5	30	30	W
Anode input power	W_{ia}	=	1248	1035	750	W
Anode dissipation	W_a	=	248	235	175	W
Output power	W_o	=	1000	800	575	W
Efficiency	η	=	80	77	77	%

R.F. CLASS B TELEPHONY

LIMITING VALUES (Absolute limits)

Frequency	f	up to 75	up to 100	up to 120	MHz
Anode voltage	V_a	= max. 4000	max. 3300	max. 2500	V
Anode input power	W_{ia}	= max. 400	max. 320	max. 240	W
Anode dissipation	W_a	=	max. 250		W
Anode current	I_a	=	max. 250		mA
Grid No. 2 voltage	V_{g2}	=	max. 600		V
Grid No. 2 dissipation	W_{g2}	=	max. 23		W

OPERATING CONDITIONS

Frequency	f	=	75	75	75	MHz
Anode voltage	V_a	=	4000	3000	2500	V
Grid No. 2 voltage	V_{g2}	=	500	500	500	V
Grid No. 1 voltage	V_{g1}	=	-100	-90	-84	V
Anode current	I_a	=	94	125	150	mA
Grid No. 2 current	I_{g2}	=	0	0	0	mA
Peak grid No. 1 A.C. voltage	V_{g1p}	=	55.5	61	66	V
Anode input power	W_{ia}	=	376	375	375	W
Anode dissipation	W_a	=	250	250	250	W
Output power	W_o	=	126	125	125	W
Efficiency	η	=	33.5	33	33	%
Modulation factor	m	=	100	100	100	%
Grid No. 1 current	I_{g1}	=	0.5	2	5.5	mA
Grid No. 1 input power	W_{ig1}	=	0.06	0.25	0.75	W
Grid No. 2 dissipation	W_{g2}	=	4	3.8	6	W

R.F. CLASS C ANODE AND SCREEN GRID MODULATION

LIMITING VALUES (Absolute limits)

Frequency	f	up to 75	up to 100	up to 120	MHz
Anode voltage	V_a	= max. 3200	max. 2600	max. 2000	V
Anode input power	W_{ia}	= max. 825	max. 660	max. 500	W
Anode dissipation	W_a	=	max. 165		W
Anode current	I_a	=	max. 275		mA
Grid No. 2 voltage	V_{g2}	=	max. 600		V
Grid No. 2 dissipation	W_{g2}	=	max. 35		W
Negative grid No. 1 voltage	$-V_{g1}$	=	max. 500		V
Grid No. 1 current	I_{g1}	=	max. 20		mA

OPERATING CONDITIONS

Frequency	f	=	75	75	MHz
Anode voltage	V_a	=	3000	2500	V
Grid No. 2 voltage	V_{g2}	=	400	400	V
Grid No. 1 voltage	V_{g1}	=	-310	-200	V
Anode current	I_a	=	225	200	mA
Grid No. 2 current	I_{g2}	=	30	30	mA
Grid No. 1 current	I_{g1}	=	9	9	mA
Peak grid No. 1 A.C. voltage	V_{g1p}	=	400	280	V
Grid No. 1 input power	W_{ig1}	=	3.3	2.3	W
Grid No. 2 dissipation	W_{g2}	=	12	12	W
Anode input power	W_{ia}	=	675	500	W
Anode dissipation	W_a	=	165	125	W
Output power	W_o	=	510	375	W
Efficiency	η	=	75.5	75	%
Modulation factor	m	=	100	100	%
Peak grid No. 2 A.C. voltage	V_{g2p}	=	350	350	V
Modulation power	W_{mod}	=	344	256	W



R.F. CLASS B SINGLE SIDE BAND AMPLIFIER

LIMITING VALUES (Absolute limits)

Frequency	f	up to	30	MHz
Anode voltage	V_a	= max.	4	kV
Anode current	I_a	= max.	350	mA
Anode input power	W_{ia}	= max.	1250	W
Peak anode dissipation	W_{ap}	= max.	275	W ¹⁾
Anode dissipation (Averaging time	W_a t_{av}	= max.	250	W 5 sec)
Grid No.2 voltage	V_{g2}	= max.	600	V
Grid No.2 dissipation	W_{g2}	= max.	35	W
Grid No.1 circuit resistance	R_{g1}	= max.	250	kΩ

OPERATING CONDITIONS

f	=	30	30	30	30	30	30	MHz
V_a	=	4	3.5	4	3.5	3	2.5	kV
V_{g1}	=	-105	-110	-105	-98	-94	-91	V
V_{g2}	=	550	600	500	500	500	500	V
V_{g1p}	=	0 105	0 110	0 105	0 98	0 94	0 91	V
I_a	=	50 182	50 207	50 164	50 164	50 164	50 164	mA
I_{g1}	=	0 0	0 0	0 0	0 0	0 0	0 0	mA
I_{g2}	=	0 9	0 12	0 8	0 9	0 10	0 10.5	mA
W_{ig1}	=	0 0	0 0	0 0	0 0	0 0	0 0	W
W_{g2}	=	0 5	0 7.2	0 4	0 4.5	0 5	0 5.3	W
W_{ia}	=	200 730	175 725	200 660	175 575	150 490	125 410	W
W_a	=	200 220	175 235	200 200	175 175	150 157	125 140	W
W_o	=	- 510	- 490	- 460	- 400	- 333	- 270	W
η	=	- 69	- 67	- 70	- 69	- 68	- 66	%

¹⁾ Max. value during a modulation cycle.

A.F. CLASS B AMPLIFIER OR MODULATOR

LIMITING VALUES (Absolute limits)

Anode voltage	V_a	= max.	4	kV
Anode dissipation	W_a	= max.	250	W
Anode current	I_a	= max.	350	mA
Grid No.2 voltage	V_{g_2}	= max.	600 ¹⁾	V
Grid No.2 dissipation	W_{g_2}	= max.	35	W
Negative grid No.1 voltage	$-V_{g_1}$	= max.	500	V
Grid No.1 current	I_{g_1}	= max.	30	mA
Grid No.1 circuit resistance	R_{g_1}	= max.	250	k Ω

OPERATING CONDITIONS, two tubes. $I_{g_1} > 0$

V_a	=	3000	2500	2000	1500	V
V_{g_2}	=	300	300	300	300	V
V_{g_1}	=	-55	-51	-49	-45	V
$R_{aa\sim}$	=	14	9.2	6.6	4.55	k Ω
V_{g1g1p}	=	0 280	0 306	0 328	0 323	V
I_a	=	2x50 2x275	2x50 2x312	2x50 2x347	2x50 2x347	mA
I_{g_2}	=	0 2x34.5	0 2x44	0 2x55	0 2x58	mA
I_{g_1}	=	0 2x15	0 2x21	0 2x27	0 2x28	mA
W_{ig_1}	=	0 2x1.9	0 2x2.9	0 2x4	0 2x4	W
W_{g_2}	=	0 2x10.5	0 2x13	0 2x16.5	0 2x17.5	W
W_{ia}	=	2x150 2x825	2x125 2x780	2x100 2x694	2x75 2x520	W
W_a	=	2x150 2x205	2x125 2x210	2x100 2x207	2x75 2x190	W
W_o	=	0 1240	0 1140	0 974	0 660	W
d_{tot}	=	- 5	- 5	- 5	- 5	%
η	=	- 75	- 73	- 70	- 63.5	%

¹⁾ V_{g_2} = max. 1000 V, when the temperature of the pin seals is max. 120 °C

A.F. CLASS-B AMPLIFIER OR MODULATOR

LIMITING VALUES See previous page.

OPERATING CONDITIONS

Two tubes. $I_{g1} = 0$.

V_a	=	3000	2500	2000	1500	V
V_{g2}	=	500	500	500	500	V
V_{g1}	=	-94	-91	-88	-85	V
R_{aa}	=	22	18	14,5	10	k Ω
V_{g1g1p}	=	0 184	0 178	0 173	0 164	V
I_a	=	2 x 50 2 x 155	2 x 50 2 x 155	2 x 50 2 x 150	2 x 50 2 x 150	mA
I_{g2}	=	0 2 x 10	0 2 x 10,5	0 2 x 14,5	0 2 x 15,5	mA
W_{g2}	=	0 2 x 5	0 2 x 5,3	0 2 x 7,3	0 2 x 7,8	W
W_{ja}	=	2 x 150 2 x 465	2 x 125 2 x 387	2 x 100 2 x 300	2 x 75 2 x 225	W
W_a	=	2 x 150 2 x 147	2 x 125 2 x 132	2 x 100 2 x 105	2 x 75 2 x 91	W
W_o	=	0 635	0 510	0 390	0 268	W
d_{tot}	=	- 2,8	- 2,6	- 3,2	- 3	%
η	=	- 68	- 66	- 65	- 60	%

