

# QT-Brightek High Power Series

## High Power VCSEL IR LED

**Part No.: QBHP684E-VXXX**

**XXX = 850nm or 940nm**

---

**Table of Contents:**

Introduction .....	3
Electrical / Optical Characteristic (Ta=25 °C) .....	4
Absolute Maximum Rating .....	4
Characteristic Curves.....	5
IR Reflow Soldering Profile .....	7
Packing .....	8
Labeling .....	9
Ordering Information .....	9
Revision History .....	10
Disclaimer .....	10

## Introduction

**Feature:**

- 1W High Power IR LED
- Packed in tape and reel
- High radiant power output
- Viewing Angle 25° typ.

**Description:**

This 1W high power IR LED has compact size of 3.5 x 3.5mm. It is ideal for both infrared sensing applications.

**Application:**

- Infrared Sensor
- Photoelectric Sensors
- Optical Encoders

**Certification & Compliance:**

- TS16949
- ISO9001
- RoHS Compliant



## Outline Dimensions:

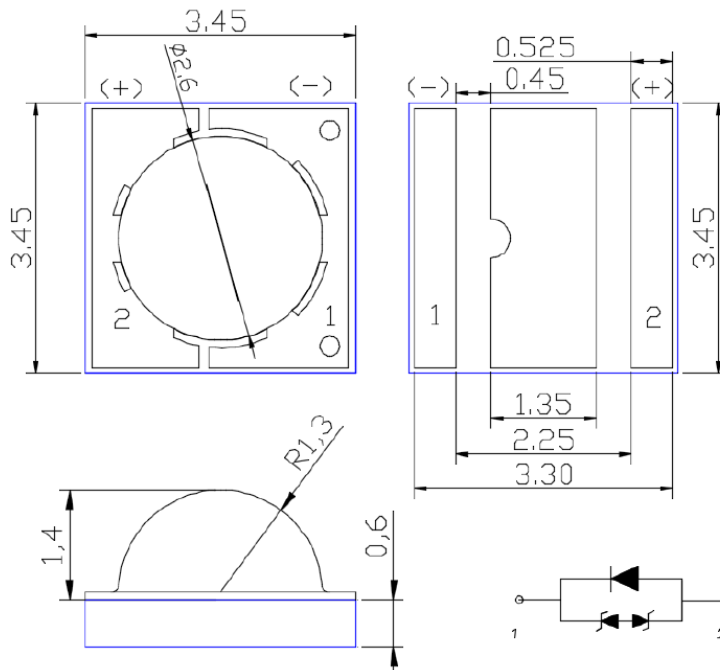

Units: mm / tolerance = +/-0.1mm

**Electrical / Optical Characteristic (Ta=25 °C)**

Product Number	Color	I <sub>F</sub> (mA)	V <sub>F</sub> (V)			λ <sub>p</sub> (nm)			P <sub>o</sub> (mW)	
			Min.	Typ.	Max.	Min.	Typ.	Max.	Min.	Typ.
QBHP684-V940	Infrared	1200	1.8	-	2.8	930	940	950	700	1000
QBHP684-V850						840	850	860		

**Absolute Maximum Rating**

I <sub>FP</sub> (mA)	T <sub>OP</sub> (°C)	T <sub>ST</sub> (°C)	T <sub>SOL</sub> (°C)
1500	-40 to +85	-40 to +100	260

\*D=0.01s duty 1/10

**Radiometric Power P<sub>o</sub> @ I<sub>F</sub>=1200mA**

Bin	Min.	Max.	Unit
P7	700	800	mW
P8	800	900	
P9	900	1000	
P10	1000	1100	

**Forward Voltage V<sub>F</sub> @ I<sub>F</sub>=1200mA**

Bin	Min.	Max.	Unit
V1	1.8	2.2	mW
V2	2.2	2.6	
V3	2.6	2.8	

Tolerance of measurement of forward voltage: ±0.1V

Tolerance of measurement of Radiometric Power: ±15%

Tolerance of measurement of Peak wavelength: ±2nm

## Characteristic Curves

Spectrum Distribution

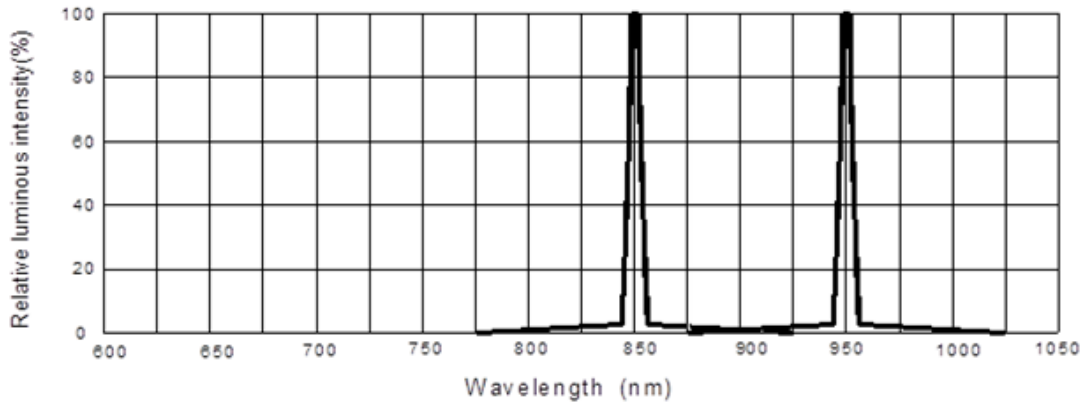

Forward Current VS. Forward Voltage

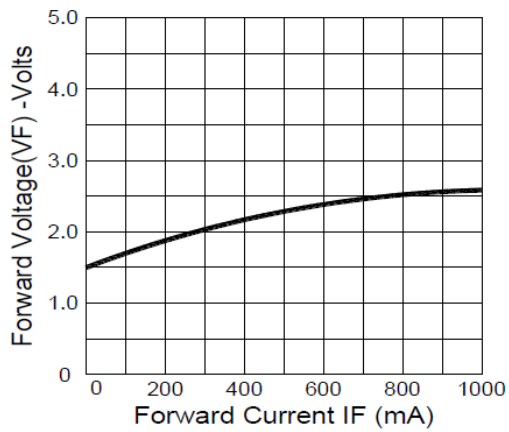

Luminous Intensity VS. Forward Current

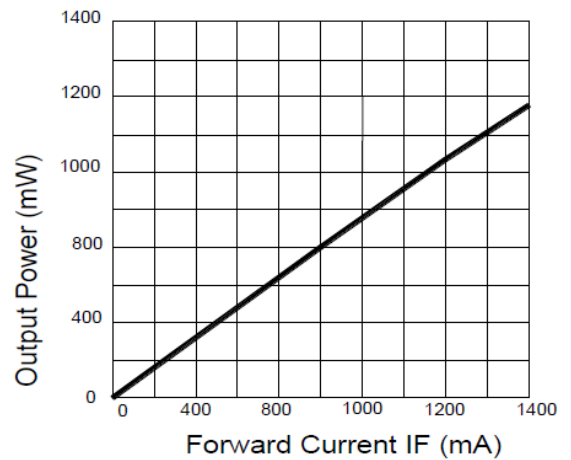

### Beam Divergence for 940nm

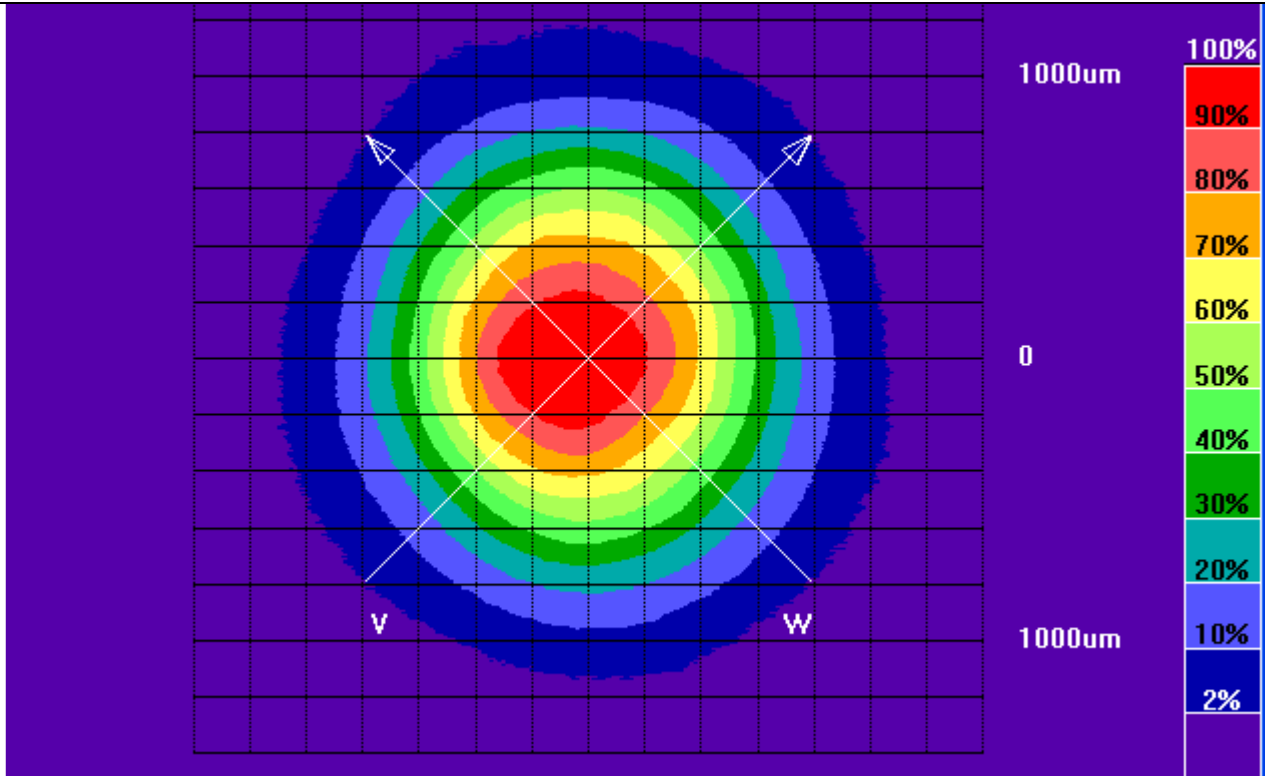

### Beam Divergence for 850nm

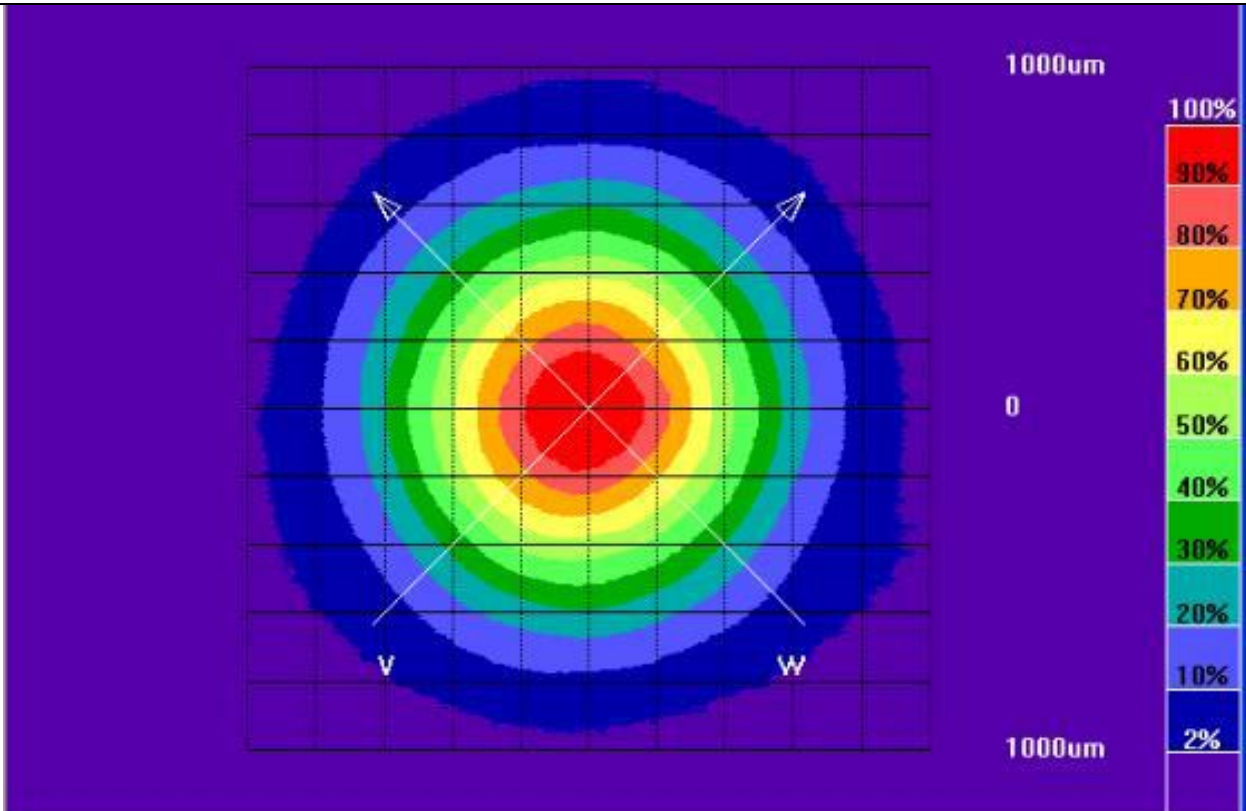

## IR Reflow Soldering Profile

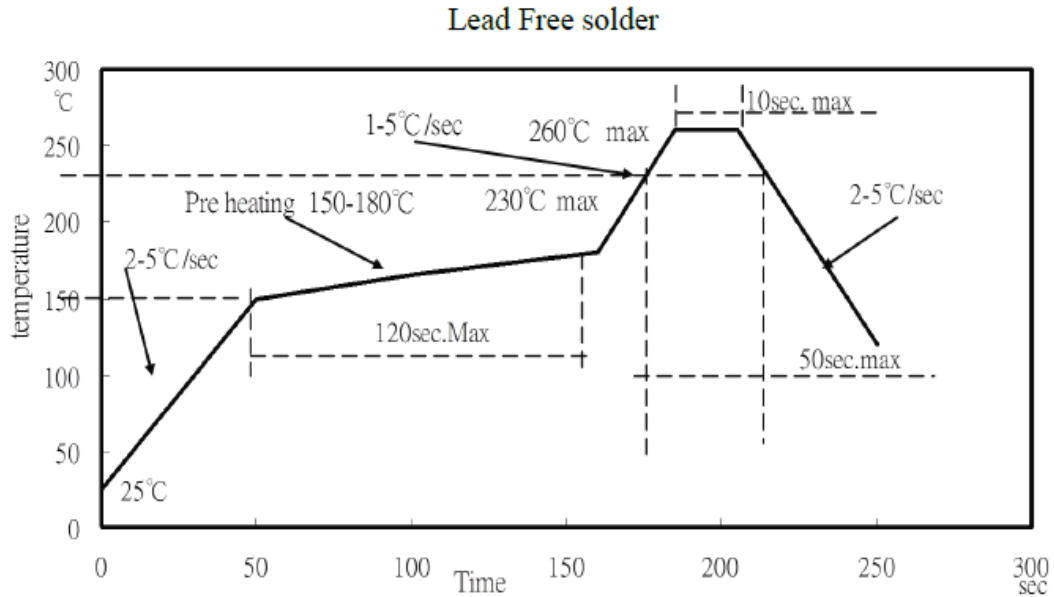

### Recommended Soldering Pad:

RECOMMENDED PCB SOLDER PAD

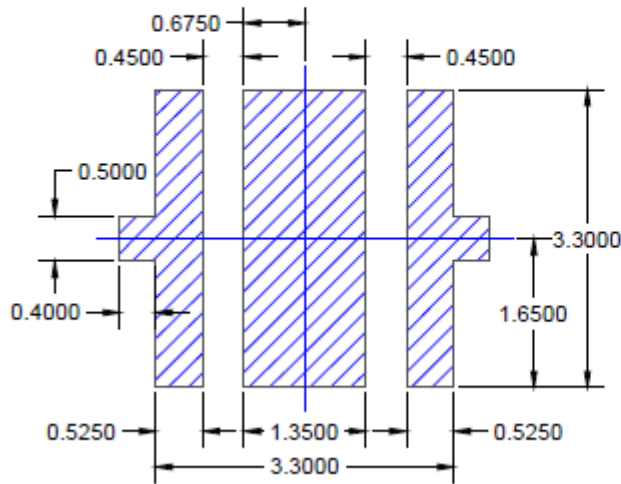

RECOMMENDED STENCIL PATTERN (HATCHED AREA IS OPENING)

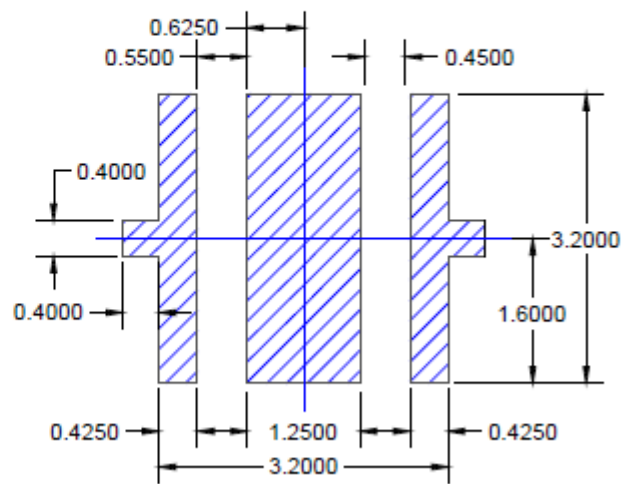

Unit: mm

## Packing

### Tape and Reel:

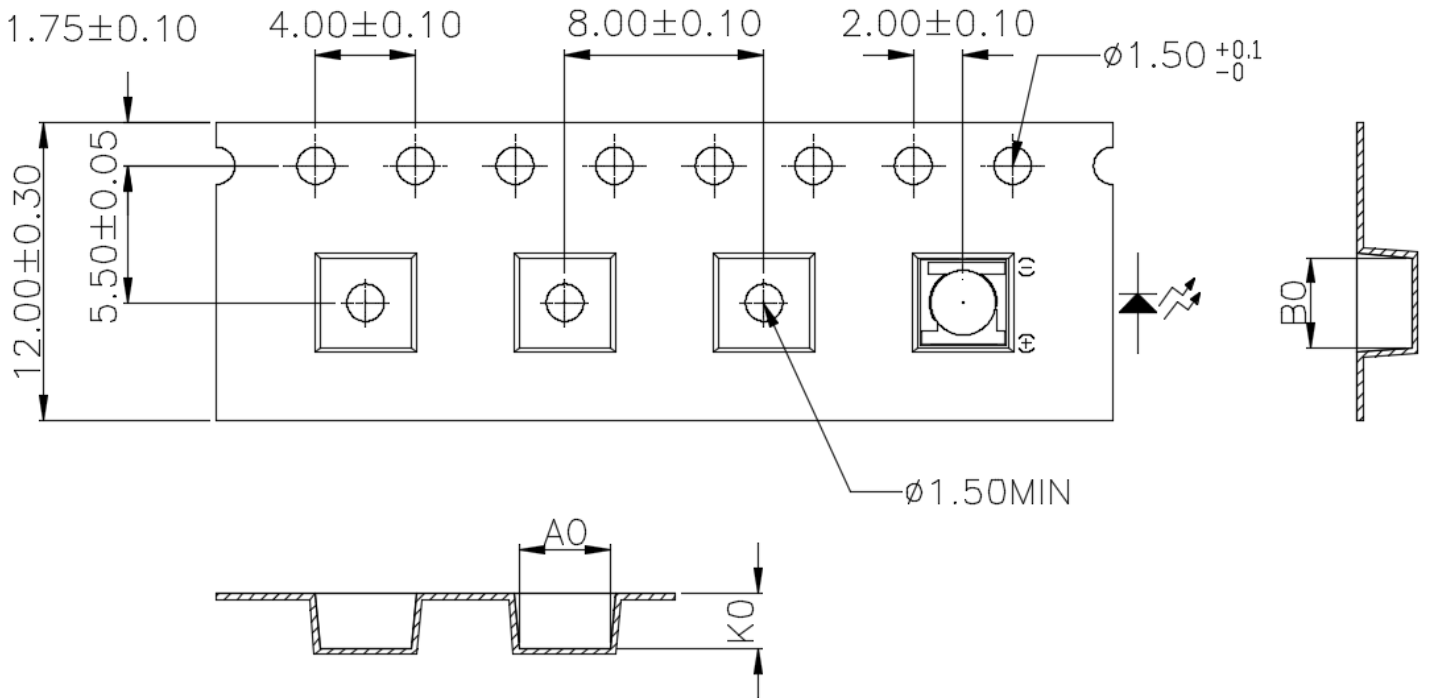

1. 10 sprocket hole pitch cumulative tolerance  $\pm 0.20$ .
2. Carrier camber is within 1 mm in 250 mm.
3. Material : Black Conductive Polystyrene Alloy.
4. All dimensions meet EIA-481-D requirements.
5. Thickness :  $0.30 \pm 0.05$  mm.

T	$0.30 \pm 0.05$
A0	$3.80 \pm 0.1$
B0	$3.80 \pm 0.1$
K0	$2.20 \pm 0.1$

Unit: mm



**Labeling**

Part No: \_\_\_\_\_

Customer P/N: \_\_\_\_\_

Item: \_\_\_\_\_

Q'ty: \_\_\_\_\_

Vf: \_\_\_\_\_

Iv: \_\_\_\_\_

WI: \_\_\_\_\_

Date: \_\_\_\_\_

**Made in Taiwan****Ordering Information**

Part #	Orderable Part #	Spec Range	Quantity per reel
QBHP684E-V940	QBHP684E-V940	P <sub>o</sub> =1000mW typ., λ <sub>p</sub> =940nm typ. @ I <sub>F</sub> =1000mA	1000
QBHP684E-V850	QBHP684E-V850	P <sub>o</sub> =1000mW typ., λ <sub>p</sub> =940nm typ. @ I <sub>F</sub> =1000mA	1000

## Revision History

Description:	Revision #	Revision Date
New Release of QBHP684E-VXXX	V1.0	08/14/2019

## Disclaimer

QT-BRIGHTTEK reserves the right to make changes without further notice to any products herein to improve reliability, function or design. QT-BRIGHTTEK does not assume any liability arising out of the application or use of any product or circuit described herein; neither does it convey any license under its patent rights, nor the rights of others.

## Life Support Policy

QT-BRIGHTTEK's products are not authorized for use as critical components in life support devices or systems without the express written approval of QT-BRIGHTTEK. As used herein:

1. Life support devices or systems are devices or systems which, (a) are intended for surgical implant into the body, or (b) support or sustain life, and (c) whose failure to perform when properly used in accordance with instructions for use provided in the labeling, can be reasonably expected to result in a significant injury of the user.
2. A critical component in any component of a life support device or system whose failure to perform can be reasonably expected to cause the failure of the life support device or system, or to affect its safety or effectiveness.