

SPECIFICATIONS

Mechanical

Mating Force: 4.50kg (9.92Lb) max.
Unmating Force: 1.00~4.00kg (2.20~8.82Lb)
Durability: 100 Cycles

QH Series

Normal Type, T/H
1.905mm [.075"] Pitch
24 Pin

Electrical

Voltage Rating: 40V (RMS)
Current Rating: 1.50A
Contact Resistance: 30mΩ max.
Dielectric Withstanding Voltage: 500V AC/1min min.
Insulation Resistance: 1000MΩ min.

Physical

Housing: Thermoplastic, UL 94V-0 rated in Ivory Color
Contact: Copper alloy
Plating: See "ORDERING INFORMATION"
Operating Temperature: -20°C to +85°C
Resistance to Soldering Heat: 250°C/15sec
Recommended Thickness of P.C.B.: 1.57[.062]

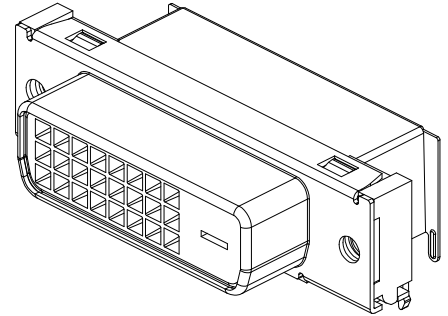

DRAWING

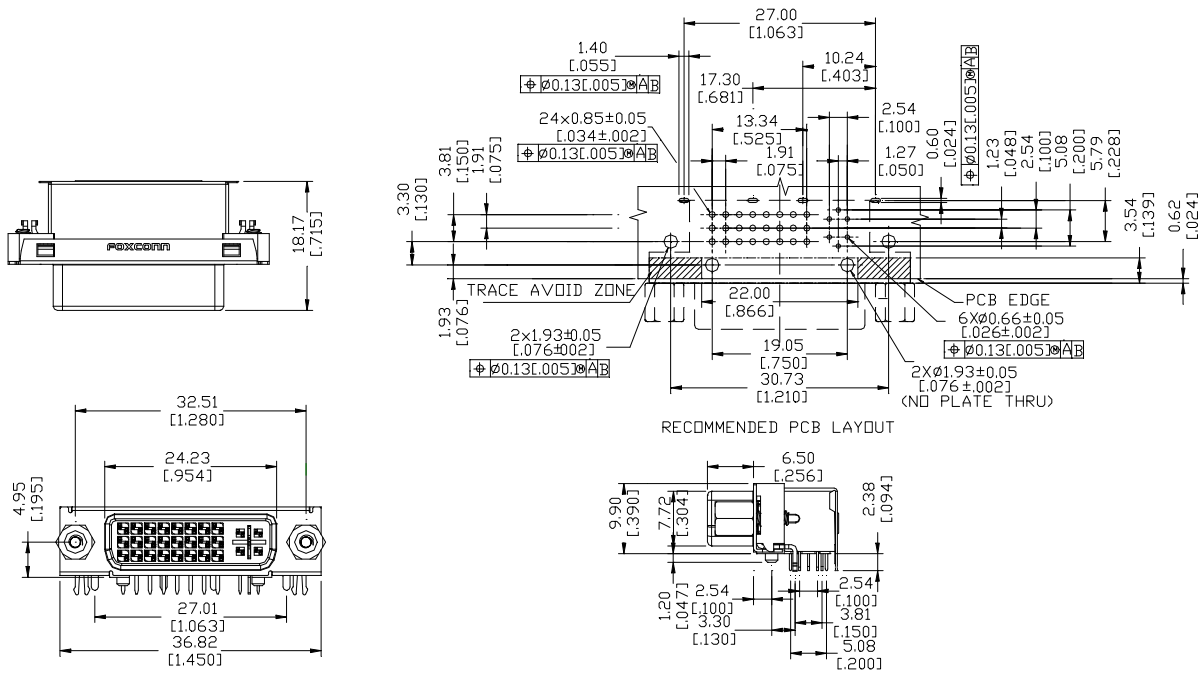

ORDERING INFORMATION

PRODUCT NO.: QH 1112 1- DJ54 - 4F

- QH Series
- Body Type: 1 = RIGHT ANGLE PCB MOUNT
- Termination Type: 1 = Female
- NO. of Pos.: 12 = 24 POS
- Contact Area Plating: 1 = GOLD FLASH
- Lead Free Part Number
- Extension Code

All specification & dimensions are subject to change, please call your nearest Foxconn sales representative for update information.