



1A Snubber Damping Rectifier

QJP-2L

Features

- High current capability
- Smoothly soft reverse recovery time (trr)
- Low profile surface mounted package in order to minimize board space
- Pb-free lead plating and halogen-free package

Mechanical data

- Case : Molded plastic, TO-92-2L.
- Epoxy : UL94-V0 rated flame retardant
- Terminals : Plated terminals, solderable per MIL-STD-202 method 208
- Polarity : Indicated by cathode band
- Mounting position : Any
- Weight : approx. 0.2 gram

Ordering Information

Device	Package	Shipping
QJP-2L-0-BK-G	TO-92-2L (Pb-free lead plating and halogen-free package)	1000 pcs / bag, 10 bags/box, 10 boxes/carton
QJP-2L-0-TB-G	TO-92-2L (Pb-free lead plating and halogen-free package)	2000 pcs / Tape & Box

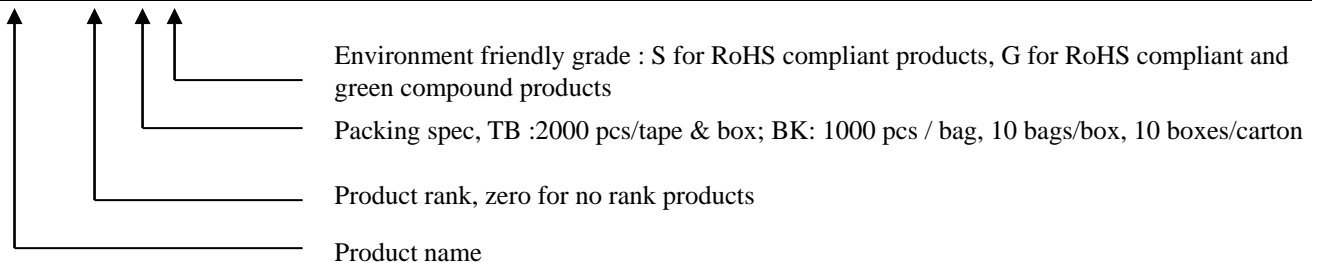

Symbol

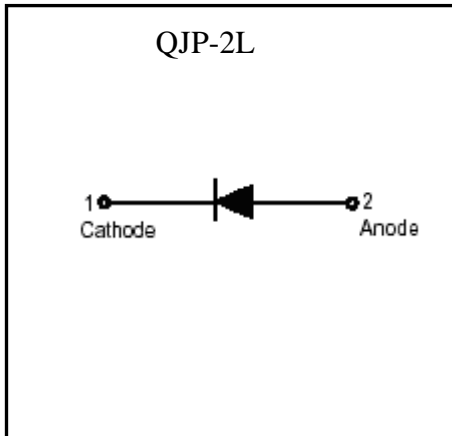

Outline

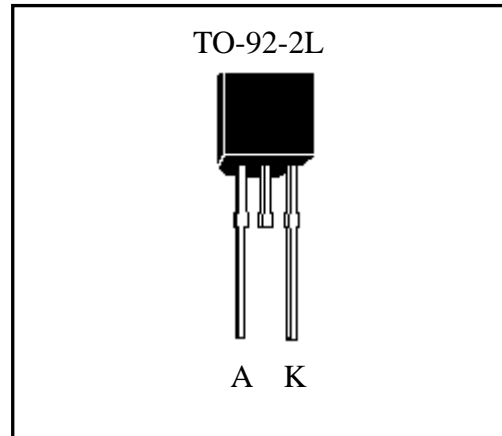

Absolute Maximum Ratings ($T_A=25^{\circ}\text{C}$, unless otherwise noted)

Parameters	Conditions	Symbol	Value	Units
Repetitive peak reverse voltage		V_{RRM}	600	V
RMS voltage		V_{RMS}	420	V
Continuous reverse voltage		V_R	600	V
Forward rectified current	Single phase half wave, 60Hz @ $T_J=25^{\circ}\text{C}$	$I_{F(AV)}$	1	A
Forward surge current	8.3ms single half sine-wave superimposed on rated load (JEDEC method)	I_{FSM}	9	A
Maximum reverse recovery time	$I_F=0.5\text{A}$, $I_R=1.0\text{A}$, $I_{RR}=0.25\text{A}$	trr	300	ns
Storage temperature range		T_{stg}	-55~+150	$^{\circ}\text{C}$
Operating junction temperature range		T_j	-55~+150	$^{\circ}\text{C}$

Thermal Data

Parameter	Symbol	Value	Unit
Thermal Resistance, Junction-to-case, max	$R_{th,j-c}$	55	$^{\circ}\text{C}/\text{W}$
Thermal Resistance, Junction-to-ambient, max	$R_{th,j-a}$	200	



Characteristics ($T_A=25^\circ\text{C}$, unless otherwise noted)

Characteristic	Symbol	Condition	Min.	Typ	Max.	Unit
	V_R	$I_R=100\mu\text{A}$	600	-	-	V
Forward Voltage	$V_F 1$	$I_F=100\text{mA}$	-	-	0.95	V
	$V_F 2$	$I_F=500\text{mA}$	-	-	1.2	
Reverse Leakage Current	I_R	$V_R=540\text{V}$	-	-	100	nA
	I_R	$V_R=540\text{V}, T_A=125^\circ\text{C}$	-	-	10	μA
Junction Capacitance	C_J	$V_R=1\text{V}, f=1\text{MHz}$	-	11.6	-	pF

Typical Characteristics

Power Derating Curve

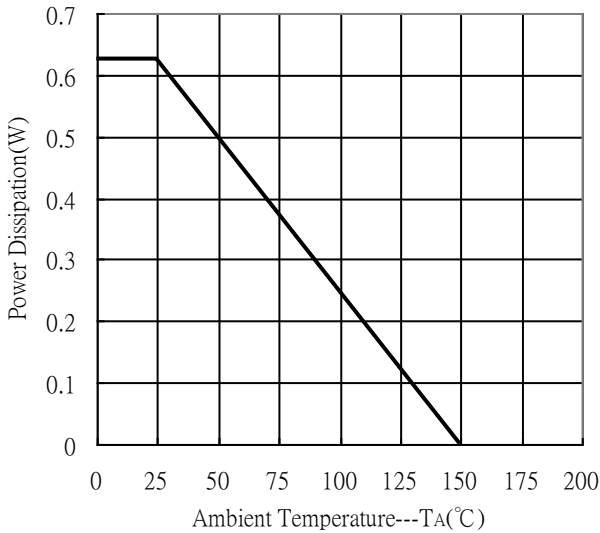

Forward Current vs Forward Voltage

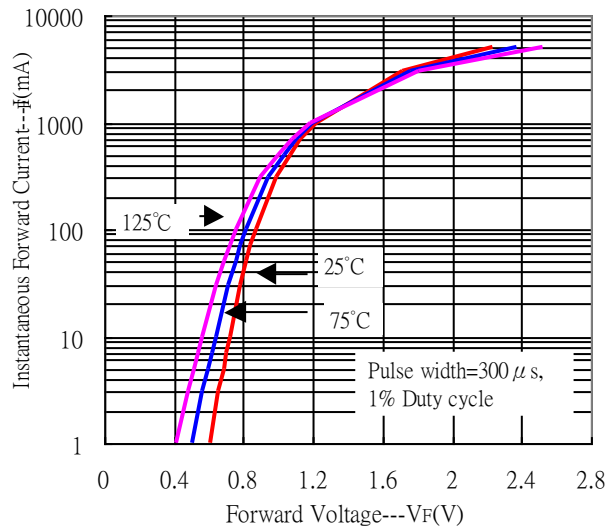

Reverse Leakage Current vs Reverse Voltage

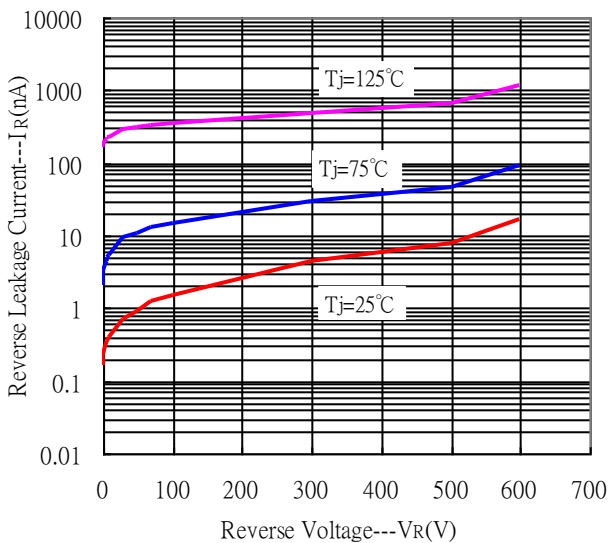

Junction Capacitance vs Reverse Voltage

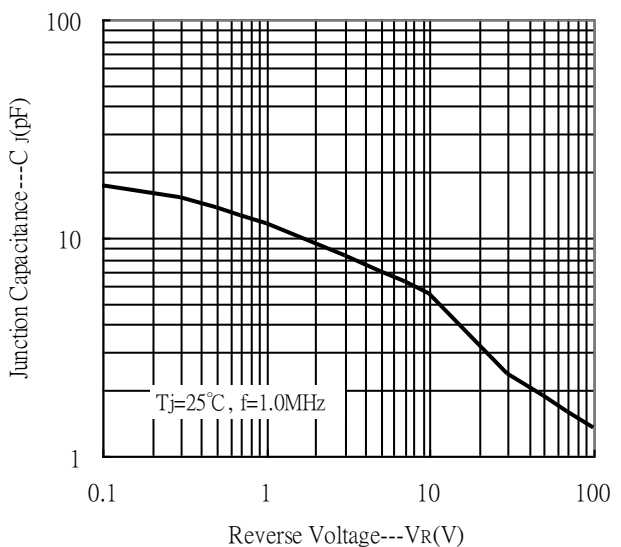

TO-92-2L Taping Outline

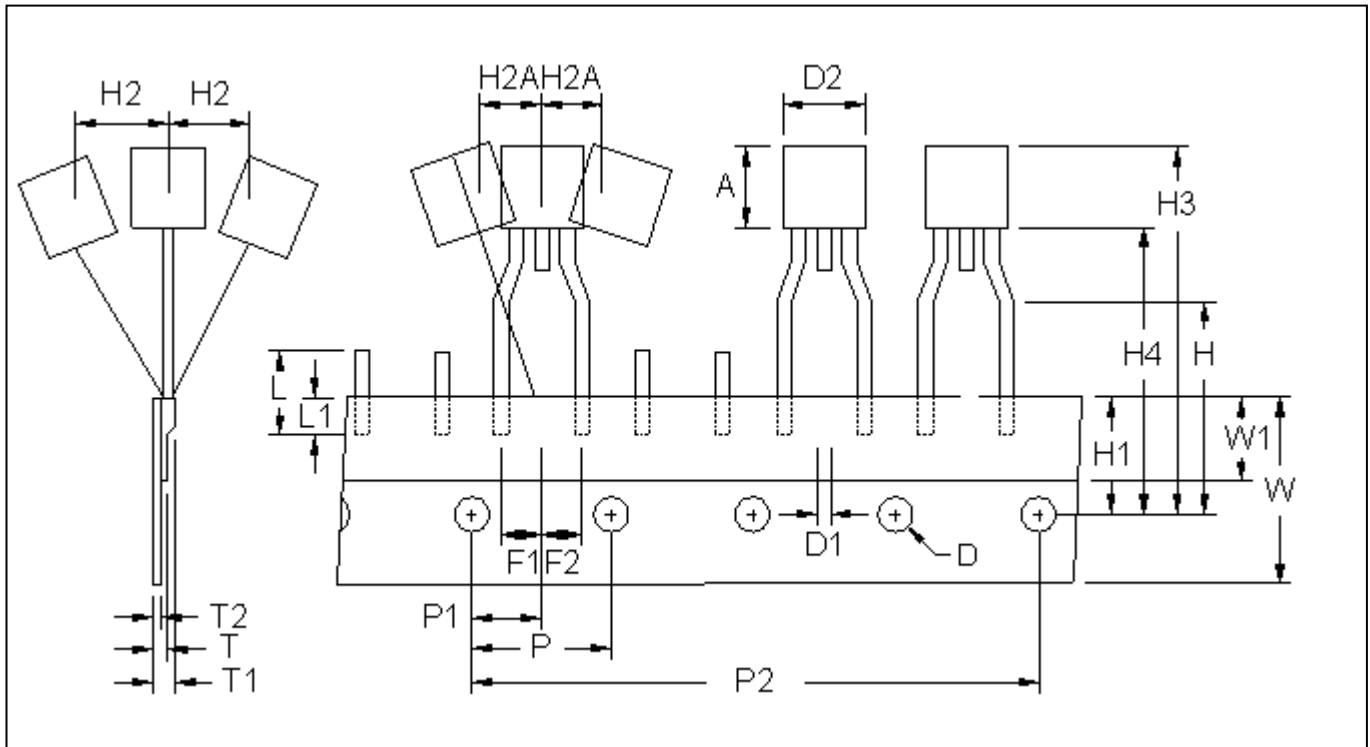

DIM	Item	Millimeters	
		Min.	Max.
A	Component body height	4.33	4.83
D	Tape Feed Diameter	3.80	4.20
D1	Lead Diameter	0.36	0.53
D2	Component Body Diameter	4.33	4.83
F1,F2	Component Lead Pitch	2.40	2.90
F1,F2	F1-F2	-	±0.3
H	Height Of Seating Plane	15.50	16.50
H1	Feed Hole Location	8.50	9.50
H2	Front To Rear Deflection	-	1
H2A	Deflection Left Or Right	-	1
H3	Component Height	-	27
H4	Feed Hole To Bottom Of Component	-	21
L	Lead Length After Component Removal	-	11
L1	Lead Wire Enclosure	2.50	-
P	Feed Hole Pitch	12.50	12.90
P1	Center Of Seating Plane Location	5.95	6.75
P2	4 Feed Hole Pitch	50.30	51.30
T	Over All Tape Thickness	-	0.55
T1	Total Taped Package Thickness	-	1.42
T2	Carrier Tape Thickness	0.36	0.68
W	Tape Width	17.50	19.00
W1	Adhesive Tape Width	5.00	7.00
-	20 pcs Pitch	253	255

Recommended wave soldering condition

Product	Peak Temperature	Soldering Time
Pb-free devices	260 +0/-5 °C	5 +1/-1 seconds

Recommended temperature profile for IR reflow

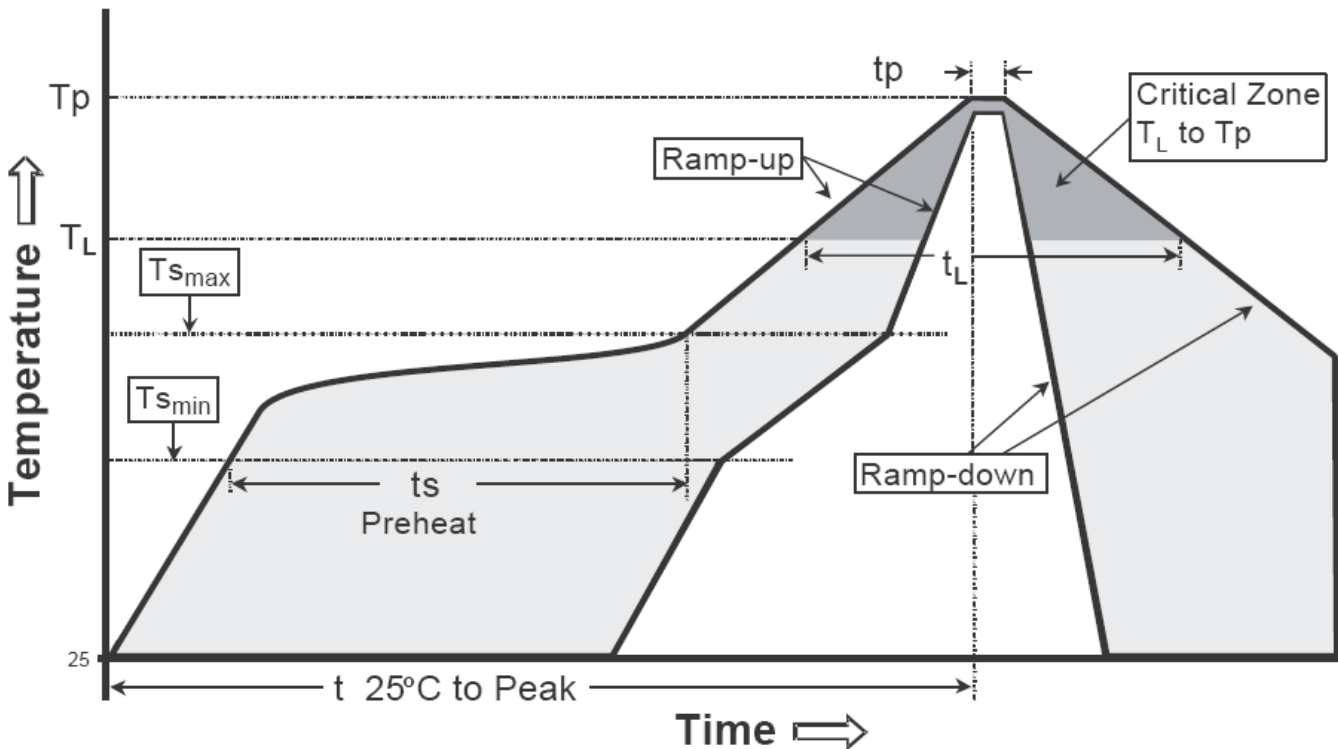

Profile feature	Sn-Pb eutectic Assembly	Pb-free Assembly
Average ramp-up rate (T _{smax} to T _p)	3°C/second max.	3°C/second max.
Preheat		
-Temperature Min(T _{s min})	100°C	150°C
-Temperature Max(T _{s max})	150°C	200°C
-Time(t _{s min} to t _{s max})	60-120 seconds	60-180 seconds
Time maintained above:		
-Temperature (T _L)	183°C	217°C
- Time (t _L)	60-150 seconds	60-150 seconds
Peak Temperature(T _p)	240 +0/-5 °C	260 +0/-5 °C
Time within 5°C of actual peak temperature(tp)	10-30 seconds	20-40 seconds
Ramp down rate	6°C/second max.	6°C/second max.
Time 25 °C to peak temperature	6 minutes max.	8 minutes max.

Note : All temperatures refer to topside of the package, measured on the package body surface.

TO-92-2L Dimension

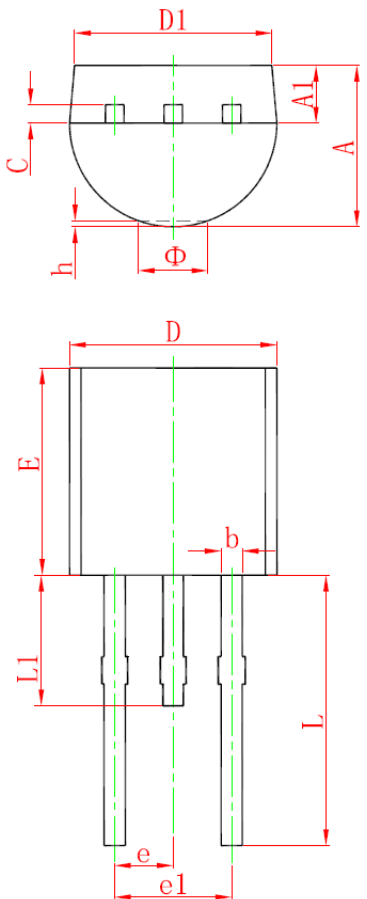

Marking:

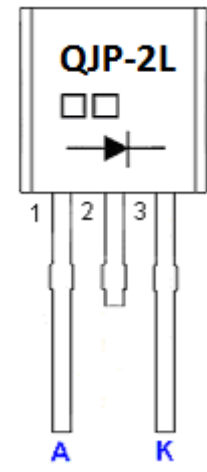

Style: Pin 1. Anode 2. Not Connected 3. Cathode

2-Lead TO-92-2L Plastic Surface Mounted Package
 CYStek Package Code: A2

DIM	Millimeters		Inches		DIM	Millimeters		Inches	
	Min.	Max.	Min.	Max.		Min.	Max.	Min.	Max.
A	3.300	3.700	0.130	0.146	e	1.270	TYP	0.050	TYP
A1	1.100	1.400	0.043	0.055	e1	2.440	2.640	0.096	0.104
b	0.380	0.550	0.015	0.022	L	14.100	14.500	0.555	0.571
c	0.360	0.510	0.014	0.020	L1	2.000	2.650	0.079	0.104
D	4.400	4.700	0.173	0.185	Φ	-	1.600	-	0.063
D1	3.430	-	0.135	-	h	0.000	0.380	0.000	0.015
E	4.300	4.700	0.169	0.185					

Notes: 1. Controlling dimension : millimeters.
 2. Lead thickness specified per L/F drawing with solder plating.
 3. If there is any question with packing specification or packing method, please contact your local CYStek sales office.

Material:

- Lead: Pure tin plated.
- Mold Compound: Epoxy resin family, flammability solid burning class: UL94V-0.

Important Notice:

- All rights are reserved. Reproduction in whole or in part is prohibited without the prior written approval of CYStek.
- CYStek reserves the right to make changes to its products without notice.
- CYStek **semiconductor products are not warranted to be suitable for use in Life-Support Applications, or systems.**
- CYStek assumes no liability for any consequence of customer product design, infringement of patents, or application assistance.