

Fans

Types	Ident No.	Heatsink	Noise dB(A)	Weight kg	Tamb max °C
Axial fan					
SKF 3-230-01	30031061	P1, P3	37	0,55	70
Radial fans					
SKF16A-230-01 ³⁾	VE001300	P16	55 57	3,6	50 40
SKF16B-230-01 ³⁾	30119362	P16	58 57	3,6	45 40
SKF17A-230-01	VE001900	P17	74	2,0	60
SKF17B-230-01	30138251	P17	73	2,8	70
SKFN4-230-01	VE001951	P18, N4	76	3,1	60
Crossflow fans					
QK08A-2EM-25-CF ³⁾	VE001400		70 71	3,5	40
QK08A-2EM-35-CF ³⁾	VE001500		70,4 71,1	4,0	40
QK10A-2DM-38-FE	VE001600		81,7	7,5	40
QK10A-2DM-38-FK	VE001701		87,7	8,0	40
QK10A-2DM-48-FK ³⁾	VE001700		83,2 87,7	10,0	40
QK08A-2DM-68-FK ³⁾	VE001800		83,3 84,2	10,0	40



Types	V ₁ (V _{VRMS}) ¹⁾ V	f Hz	P1 W	I1 A	max V _{air} / t m ³ /h	rpm min ⁻¹
Axial fan						
SKF 3-230-01	230 ¹⁾	50 60	15	0,12	159 190	2600
Radial fans						
SKF16A-230-01	230	50 60	135 152	0,60 0,68	615 575	1300 1600
SKF16B-230-01	230	50 60	160 185	0,71 0,83	610 550	1800 1730
SKF17A-230-01	230	50 60	81 115	0,36 0,51	850 950	2600 2900
SKF17B-230-01	230	50 60	140 194	0,62 0,89	1115 1260	2700 3000
SKFN4-230-01	230	50 60	155 230	0,69 0,98	1410 1540	2600 2900
Crossflow fans						
QK08A-2EM-25-CF	230	50 60	140 175	0,62 0,75	507 550	2540 2850
QK08A-2EM-35-CF	230	50 60	175 215	0,80 1,00	800 815	2400 2450
QK10A-2DM-38-FE	3 x 230/400	50	450	3 x 0,85	1360	2500
QK10A-2DM-38-FK	3 x 230/400	60	610	3 x 1,10	1640	3230
QK10A-2DM-48-FK	3 x 230/400	50 60	670 860	3 x 1,23 3 x 1,60	1880 2065	2730 3000
QK08A-2DM-68-FK	3 x 230/400	50 60	870 980	3 x 1,42 3 x 1,45	2600 2510	2630 3080

¹⁾ V₁ = 24 Vdc, 48 Vdc and 115 Vac are also available on request

³⁾ 60 Hz

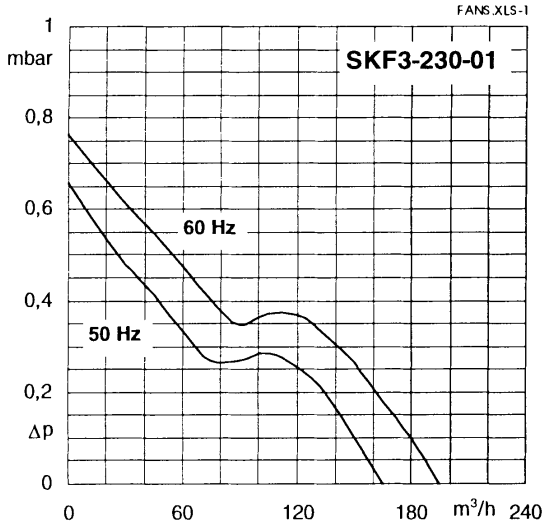

Fig. 1 Airflow vs. pressure drop

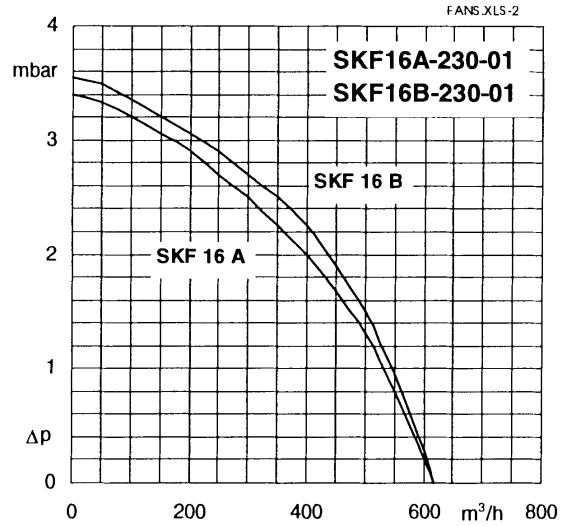

Fig. 2 Airflow vs. pressure drop

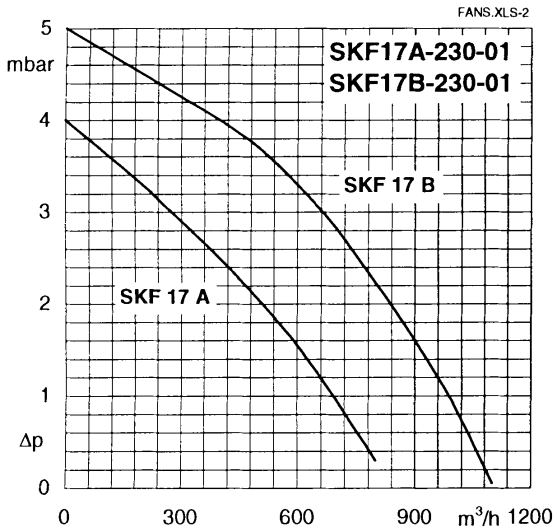

Fig. 3 Airflow vs. pressure drop

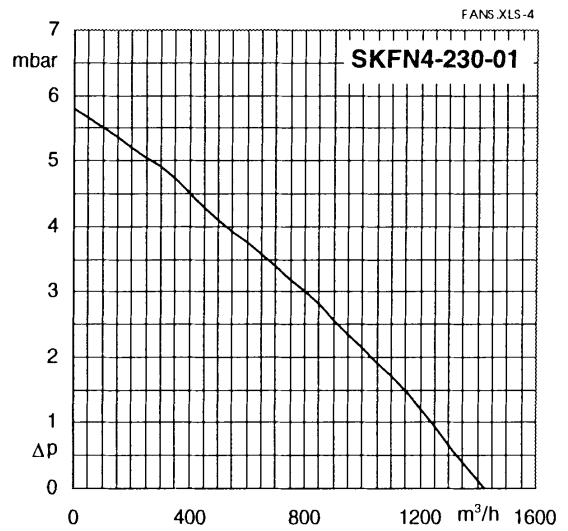

Fig. 4 Airflow vs. pressure drop

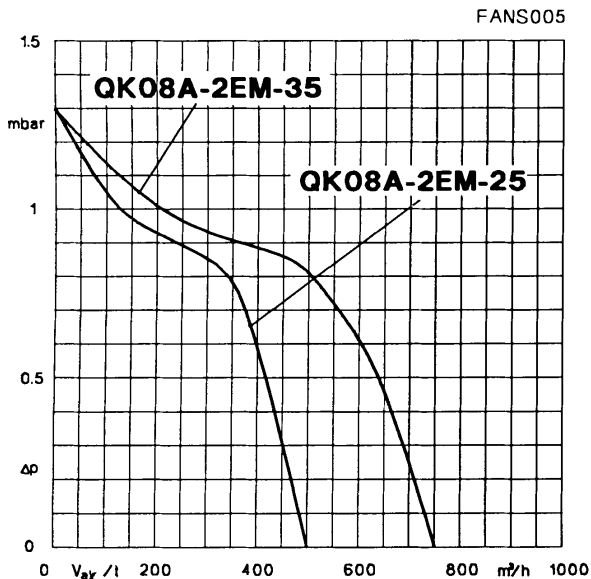

Fig. 5 Airflow vs. pressure drop

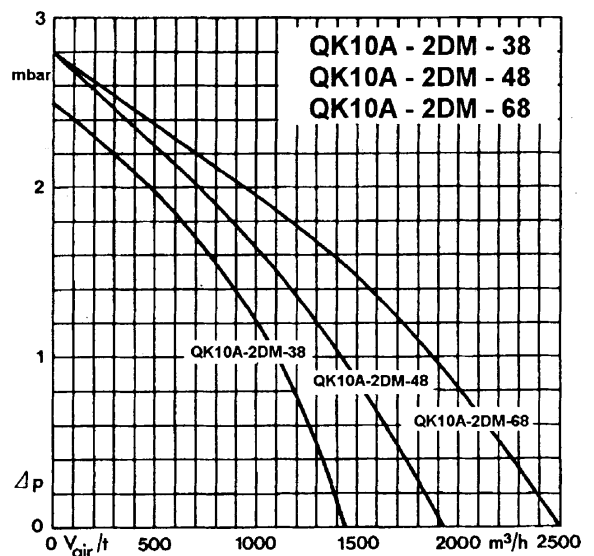
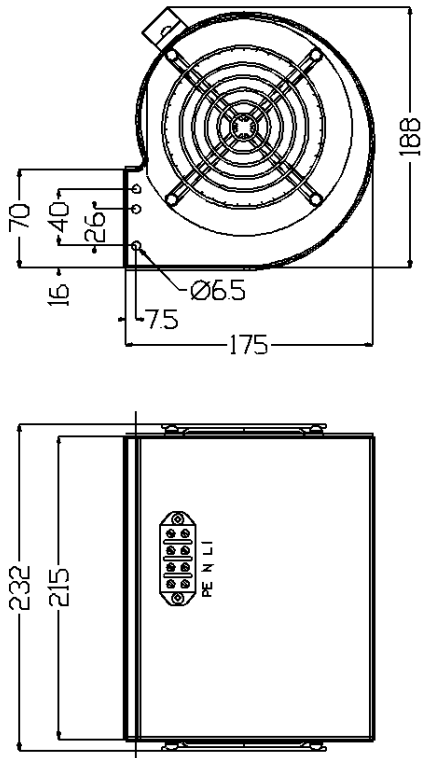
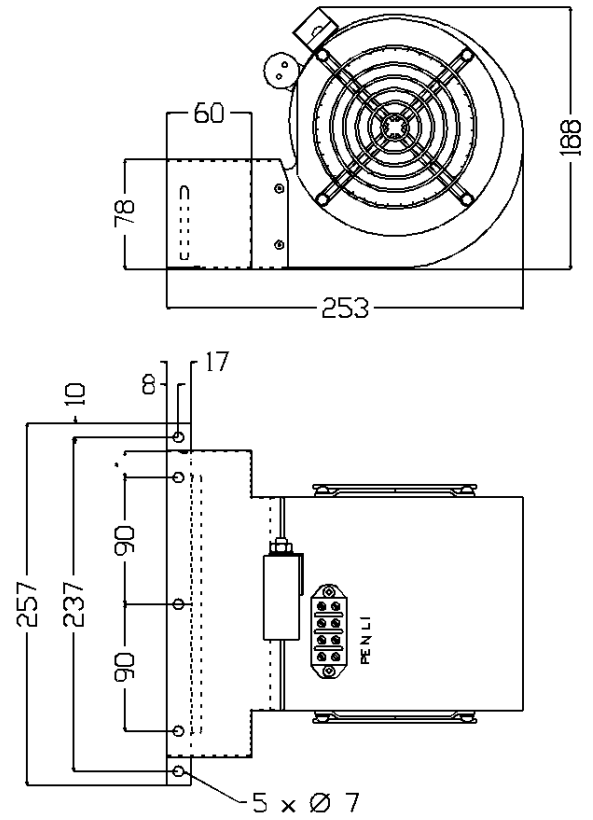

Fig. 6 Airflow vs. pressure drop

SKF 16A



SKF 16B



SKF 3

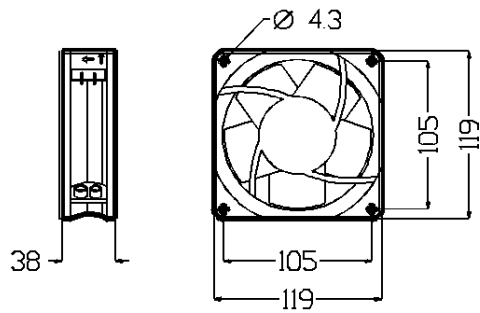

**SKF 17
SKF N4**

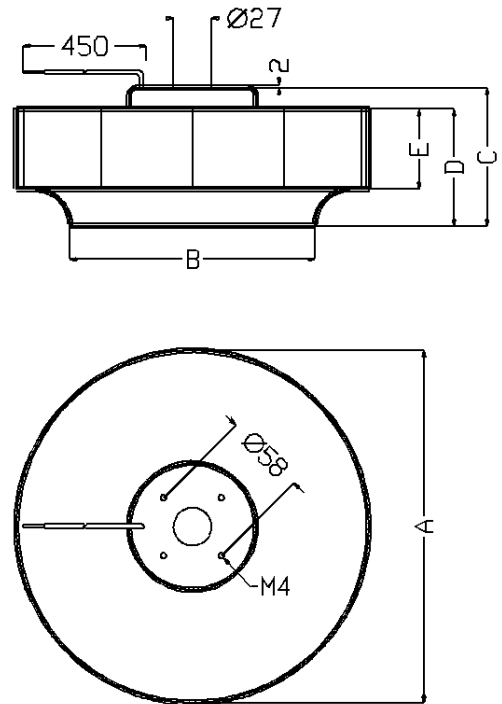

	A	B	C	D	E
SKF 17A	220	159	71	63	45
SKF 17B	227	153	99	88	64
SKF N4	252	172	99	84	57

Dimensions in mm

QK 08A

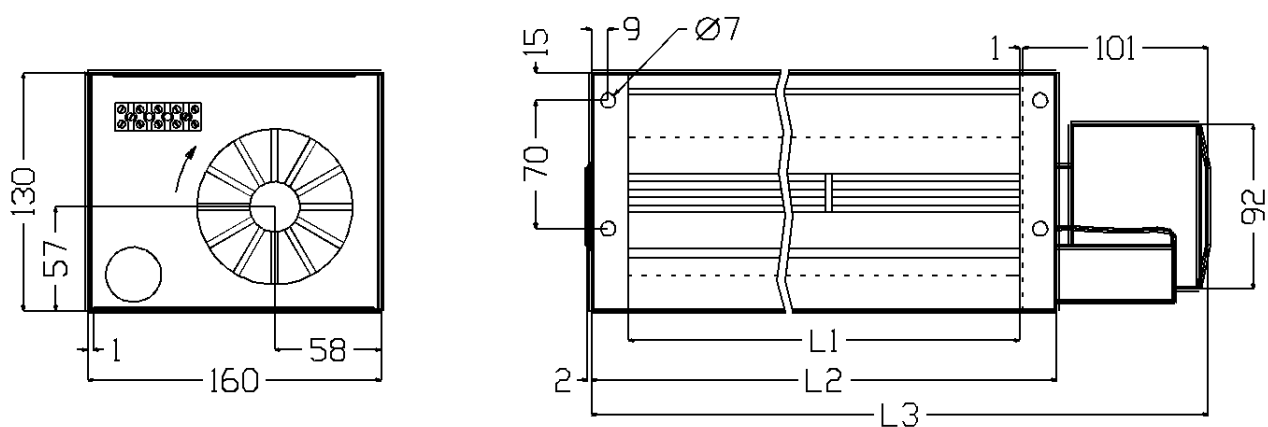

Types	Ident No.	L1	L2	L3
QK08A-2EM-25-CF	VE001400	250	290	372
QK08A-2EM-35-CF	VE001500	350	390	472

QK 10A

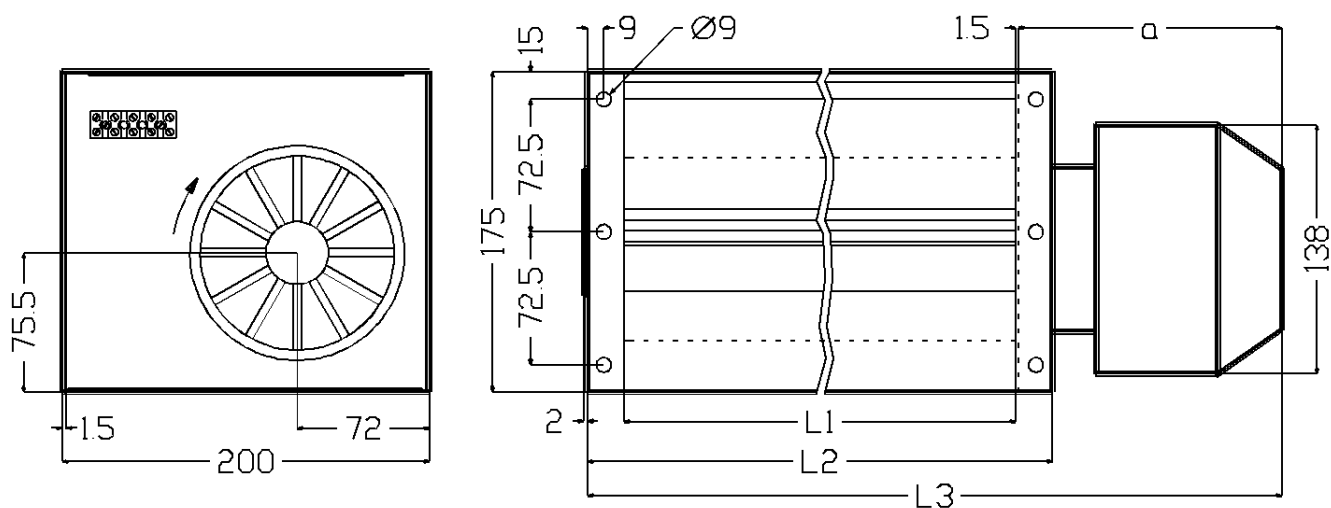

Types	Ident No.	a	L1	L2	L3
QK10A-2DM-38-FE	VE001600	126	380	420	528
QK10A-2DM-38-FK	VE001701	146	380	420	548
QK10A-2DM-48-FK	VE001700	146	480	520	648
QK10A-2DM-68-FK	VE001800	146	680	720	848

Dimensions in mm