

# QSI LASER DIODE SPECIFICATIONS FOR APPROVAL

Customer :

Model : QL85F6S-A/B/C

Signature of Approval

Approved by \_\_\_\_\_

Checked by \_\_\_\_\_

Issued by \_\_\_\_\_

Approval by Customer

---



QSI Co., Ltd.

315-9, Cheonheung-ri, Sungger-eup,  
Cheonan-city, Chungnam, Korea 330-836

[WWW.QSILaser.com](http://WWW.QSILaser.com)

# QL85F6S-A/B/C

## AlGaAs Laser Diode

Quantum Semiconductor International Co., Ltd.

Ver.1 APR.2005

### ◆ OVERVIEW

QL85F6SA is a MOCVD grown 850nm band AlGaAs laser diode with quantum well structure. It's an attractive light source, with a typical light output power of 10mW for industrial optical module and sensor applications.

### ◆ APPLICATION

- Sensor
- Industrial Optical Module

### ◆ FEATURES

- Visible Light Output :  $\lambda_p = 850 \text{ nm}$
- Optical Power Output : 10mW CW
- Package Type : TO-18 (5.6mm $\phi$ )
- Built-in Photo Diode for Monitoring Laser Diode

### ◆ ELECTRICAL CONNECTION

#### Bottom View

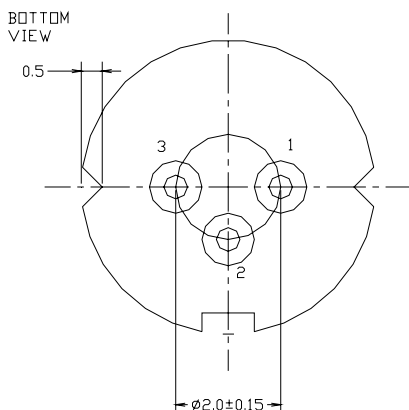

#### Pin Configuration

A	LD cathode, PD anode (Fig. 1)
B	LD , PD anode (Fig. 2)
C	LD anode, PD cathode (Fig. 3)

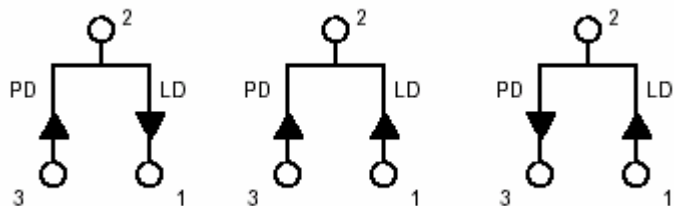

Fig. 1

QL85F6SA

Fig. 2

QL85F6SB

Fig. 3

QL85F6SC

◆ ABSOLUTE MAXIMUM RATING at Tc=25°C

Items	Symbols	Values	Unit
Optical Output Power	P	12	mW
Laser Diode Reverse Voltage	V	2	V
Photo Diode Reverse Voltage	V	30	V
Operating Temperature	Topr	-10 ~ +60	°C
Storage Temperature	Tstg	-40 ~ +85	°C

◆ ELECTRICAL and OPTICAL CHARACTERISTICS at Tc=25°C

Items	Symbols	Min.	Typ.	Max.	Unit	Condition
Optical Output Power	Po	-	10	-	mW	-
Threshold Current	Ith	5	10	20	mA	-
Operating Current	Iop	15	25	35	mA	Po=10mW
Slope Efficiency	SE	0.4	0.7	0.9	mW/mA	5~10 mW
Operating Voltage	Vop	-	1.9	2.5	V	Po=10mW
Lasing Wavelength	$\lambda_p$	845	850	855	nm	Po=10mW
Beam Divergence	$\theta_{  }$	7	9	12	deg	Po=10mW
	$\theta_{\perp}$	25	32	40	deg	Po=10mW
Beam Angle	$\Delta\theta_{  }$	-	-	$\pm 2$	deg	Po=10mW
	$\Delta\theta_{\perp}$	-	-	$\pm 3$	deg	Po=10mW
Monitor Current	Im	0.1	0.3	0.5	mA	Po=10mW
Astigmatism	As			15	$\mu\text{m}$	
Optical Distance	$\Delta X, \Delta Y, \Delta Z$	-	-	$\pm 60$	$\mu\text{m}$	

**NOTICE : QL85F6S-A/B/C to be operated on APC**

The above product specifications are subject to change without notice.

## EXAMPLE of REPRESENTATIVE CHARACTERISTICS

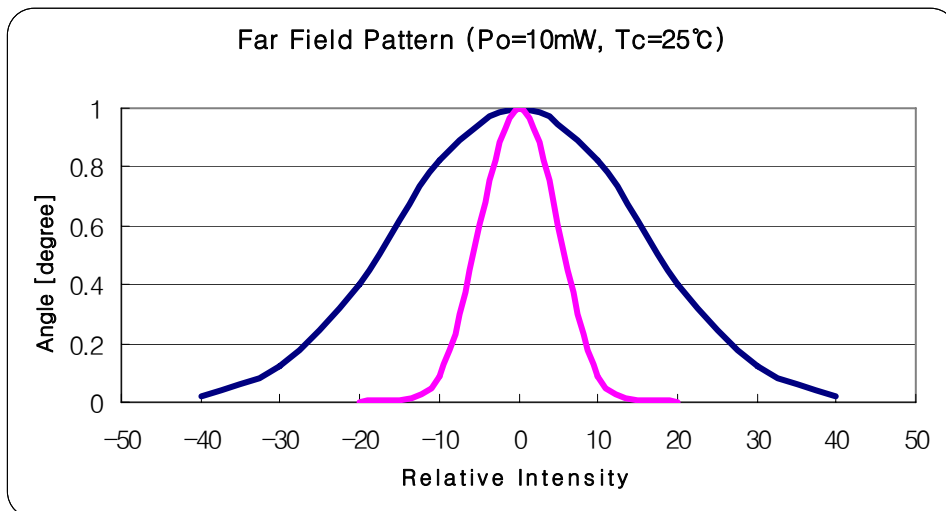
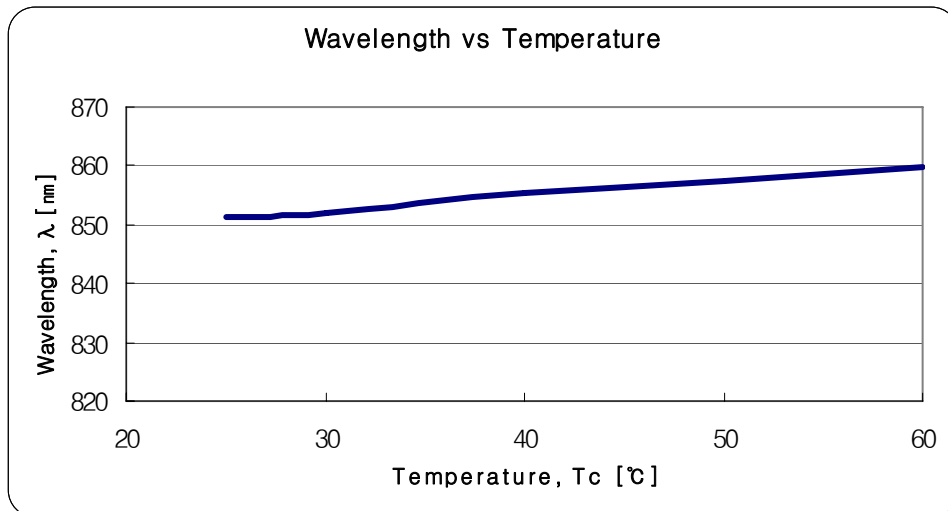
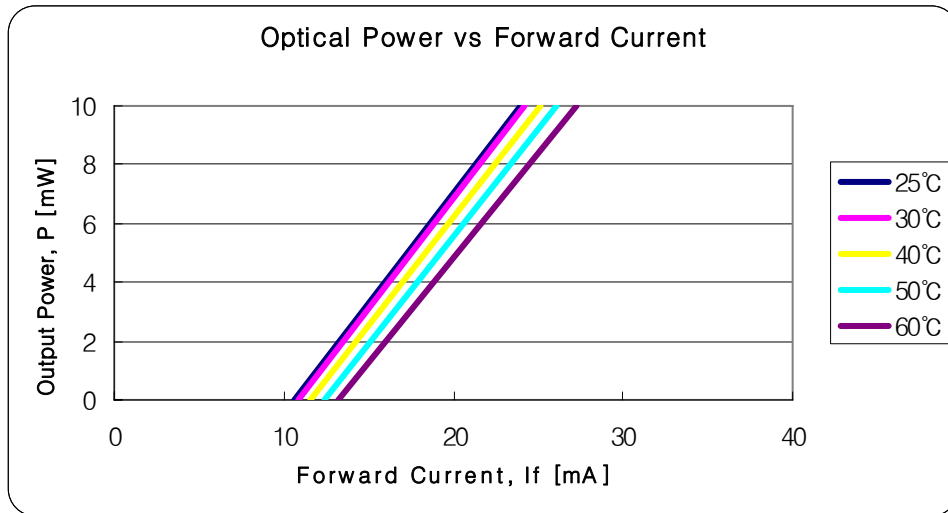

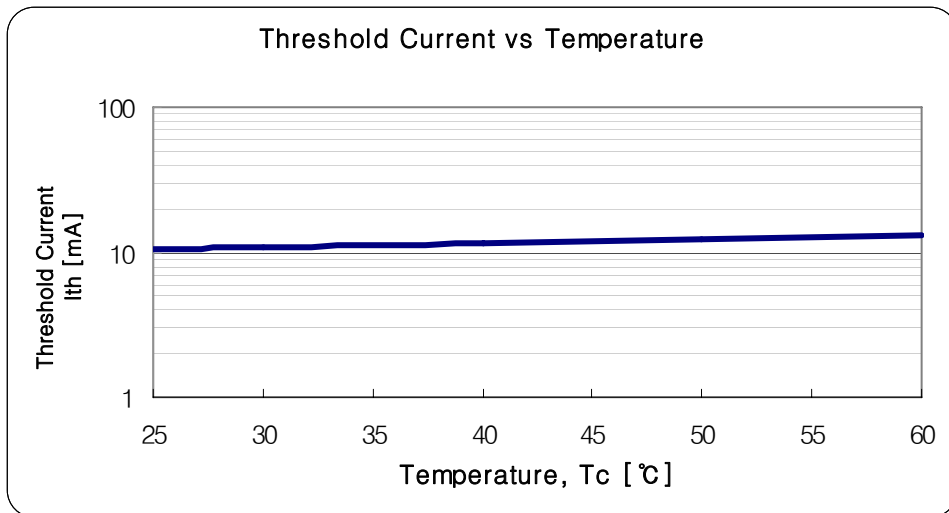
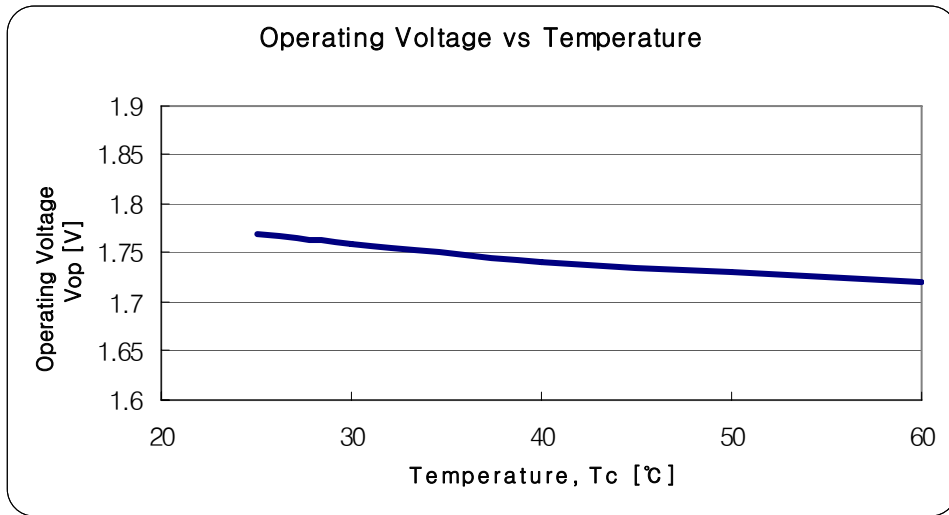
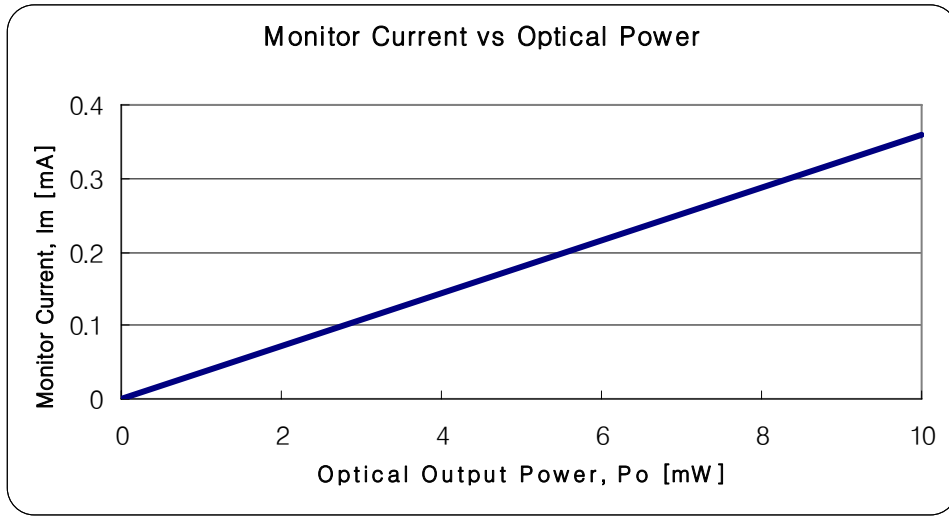

## ◆ PACKAGE DIMENSION

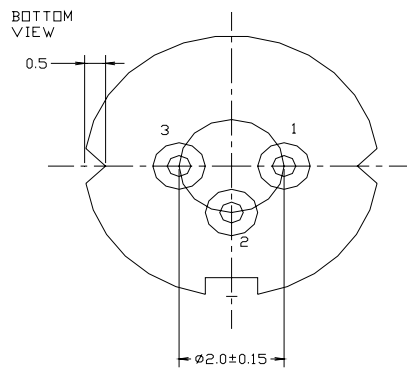
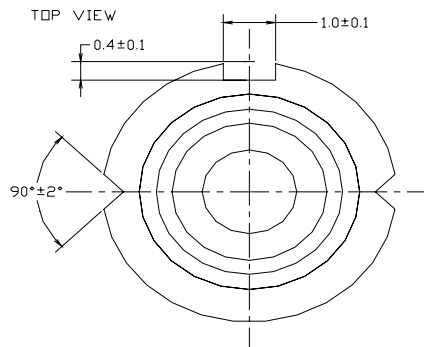
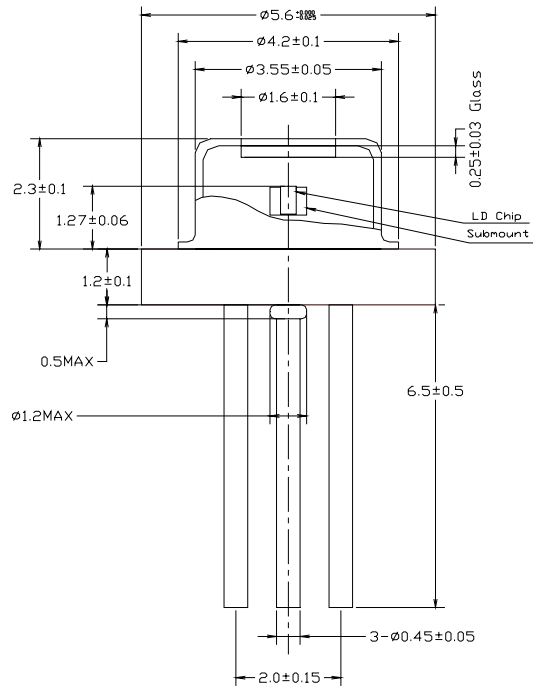

◆PACKING

