

# QDLASER

## QLF1335-AE

1310 nm FP LASER TO-CAN

Preliminary

C00052-01 Oct. 2012



### 1. DESCRIPTION

The QLF1335-AE is 1310 nm quantum dot laser diode device for use in extremely high temperature environment. The laser is mounted into a TO-56 header including a monitor PD for optical power control and hermetic sealed with a lens cap. Since quantum dot technologies are equipped with active layers of the device, it realizes excellent temperature characteristics and low power consumptions.

### 2. FEATURES

- 1310 nm FP-LD
- Temperature insensitive operation
- $\Phi 5.6\text{mm}$  TO-CAN package
- Wide temperature operation:  $-25$  to  $175\text{deg.C}$

### 3. APPLICATION

- High temperature use

### 4. ABSOLUTE MAXIMUM RATING

( $T_c = 25^\circ\text{C}$ , unless otherwise specified)

PARAMETER	SYMBOL	RATING	UNIT
Light Output Power	$P_o$	10	mW
LD Forward Current	$I_F$	300	mA
LD Reverse Voltage	$V_{RLD}$	2	V
PD Forward Current	$I_{FPD}$	2	mA
PD Reverse Current	$I_{RPD}$	5	mA
PD Reverse Voltage	$V_{RPD}$	10	V
Operation Temperature ( $T_c$ )	$T_c$	$-25$ to $175$	$^\circ\text{C}$
Storage Temperature	$T_{stg}$	$-40$ to $85$	$^\circ\text{C}$
Lead Soldering Temperature (5 s)	$T_{sld}$	230	$^\circ\text{C}$

## 5. OPTICAL AND ELECTRICAL CHARACTERISTICS

( $T_c = 25^\circ\text{C}$ , unless otherwise specified)

PARAMETER	SYMBOL	TEST CONDITION	MIN	TYP	MAX	UNIT
Threshold current	$I_{th}$	CW, 25deg.C	-	15	25	mA
		CW, 175 deg.C	-	70	85	mA
Operation current	$I_{op}$	CW, $P_o=4$ mW, 25deg.C	-	55	75	mA
		CW, $P_o=2$ mW, 175deg.C	-	110	135	mA
Operation voltage	$V_{op}$	CW, $P_o=4$ mW	-	1.3	1.6	V
Slope efficiency	$\eta$	CW, 25deg.C	0.06	0.10	-	W/A
		CW, 175deg.C	0.04	0.06	-	W/A
Center wavelength	$\lambda_c$	CW, $P_o=4$ mW, 25deg.C	1250	1306	1310	nm
Spectral width	$\Delta\lambda$	CW, $P_o=4$ mW, RMS(-20dB), 25deg.C	-	3.2	4	nm
Monitor current	$I_m$	CW, $P_o=4$ mW, $V_{RD}=5$ V	50	700	1000	$\mu\text{A}$
Focal length	$D_f$	CW, $P_o=4$ mW, SI10/125	6.1	7.1	8.1	mm

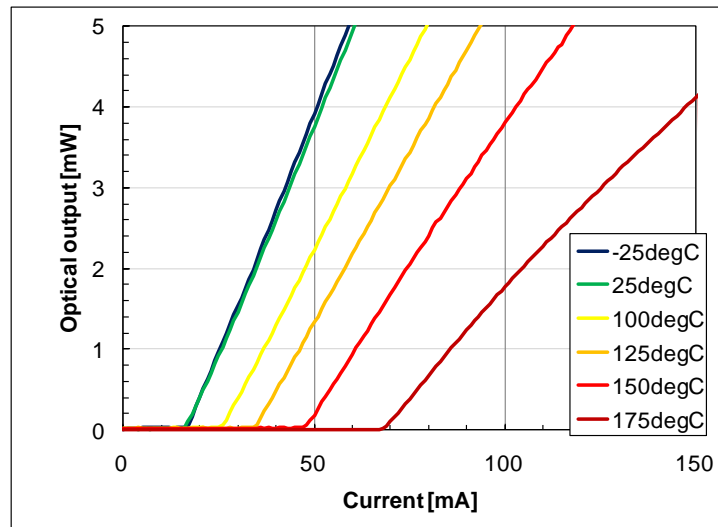
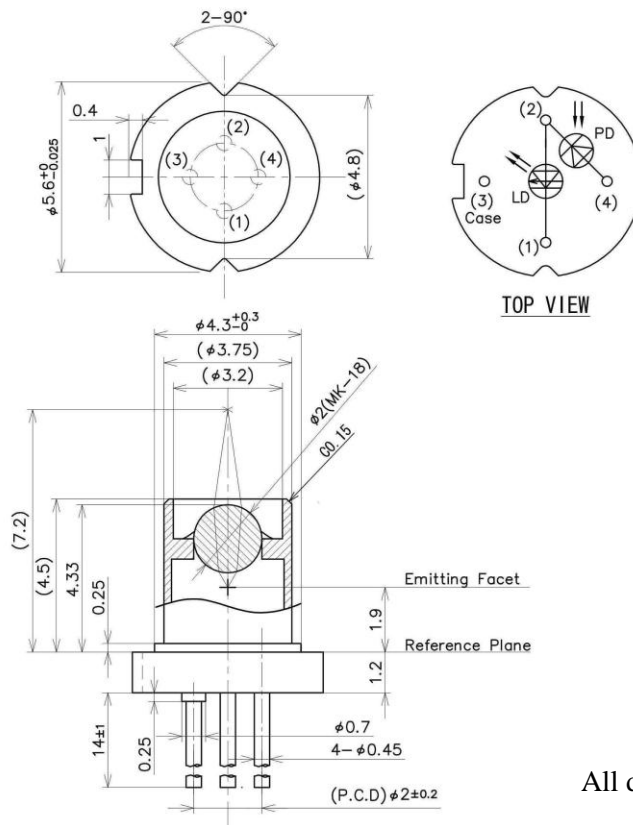

Fig. Typical I-L curve

## 6. OUTLINE DRAWING



All dimensions in millimeters

## 7. NOTICE

- Warrantary period of products

Warrantary period of products is one year from packing date.

- Safety Information

This product is classified as Class 1M laser product, and complies with 21 CFR Part 1040.10.

Please do not take a look laser lighting in operations since laser devices may cause troubles to human eyes.

Please do not eat, burn, break and make chemical process of the products since they contain GaAs material.

- Handling products

Semiconductor lasers are easily damaged by external stress such as excess temperature and ESD.

Please pay attention to handling products, and use within range of maximum ratings.

QD Laser takes no responsibility for any failure or unusual operation resulting from improper handling, or unusual physical or electrical stress.

- RoHS

This product conforms to RoHS compliance related EU Directive 2002/95/EC.

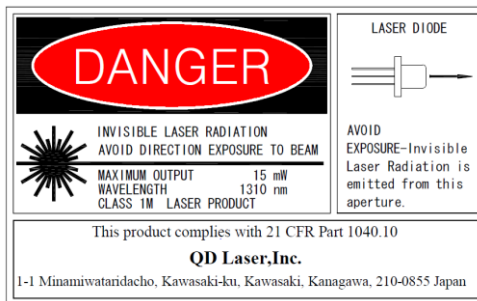

**QD Laser, Inc.**

Contact : [info@qdlaser.com](mailto:info@qdlaser.com) <http://www.qdlaser.com>

Copyright 2012 All Rights Reserved by QD Laser Inc.

Address : Keihin Bldg.1F 1-1 Minamiwataridacho, Kawasaki-ku, Kawasaki, Kanagawa Zip 210-0855 Japan

All company or product names mentioned herein are trademarks or registered trademarks of their respective owners. Information provided in this data sheet is accurate at time of publication and is subject to change without advance notice.