

Abstract

Single-Chip 3-Axis Accelerometer

QMA7981

Advanced Information

The QMA7981 is a single chip three-axis accelerometer. This surface-mount, small sized chip has integrated acceleration transducer with signal conditioning ASIC, sensing tilt, motion, shock and vibration, targeted for applications such as screen rotation, step counting, sleep quality, gaming and personal navigation in mobile and wearable smart devices.

The QMA7981 is based on our state-of-the-art, high resolution single crystal silicon MEMS technology. Along with custom-designed 14-bit ADC ASIC, it offers the advantages of low noise, high accuracy, low power consumption, and offset trimming. The device supports digital interface IIC and SPI.

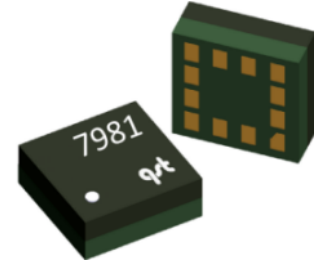

The QMA7981 is in a 2x2x0.95mm³ surface mount 12-pin land grid array (LGA) package.

FEATURES

BENEFIT

- | | |
|--|--|
| <ul style="list-style-type: none"> ▶ 3-Axis Accelerometer in a 2x2x0.95 mm³ Land Grid Array Package (LGA), guaranteed to operate over a temperature range of -40 °C to +85 °C. ▶ 14-Bit ADC with low noise accelerometer sensor ▶ I²C Interface with Standard and Fast modes. Support SPI digital interface ▶ Built-In Self-Test ▶ Wide range operation voltage (1.71V To 3.6V) and low power consumption (2-50uA low power conversion current) ▶ RoHS compliant , halogen-free ▶ Built-in motion algorithm | <ul style="list-style-type: none"> ▶ Small size for highly integrated products. Signals have been digitized and factory trimmed. ▶ High resolution allows for motion and tilt sensing ▶ High-Speed Interfaces for fast data communications. ▶ Enables low-cost functionality test after assembly in production ▶ Automatically maintains sensor's sensitivity under wide operation voltage range and compatible with battery powered applications ▶ Environmental protection and wide applications ▶ Low power and easy applications including step counting, sleep quality, gaming and personal navigation |
|--|--|

CONTENTS

CONTENTS	3
1 INTERNAL SCHEMATIC DIAGRAM	4
1.1 Internal Schematic Diagram.....	4
2 SPECIFICATIONS AND I/O CHARACTERISTICS	5
2.1 Product Specifications.....	5
2.2 Absolute Maximum Ratings	6
2.3 I/O Characteristics.....	6
3 PACKAGE PIN CONFIGURATIONS	6
3.1 Package 3-D View	6
3.2 Package Outlines.....	7
4 EXTERNAL CONNECTION	10
4.1 I2C Dual Supply Connection	10
4.2 I2C Single Supply connection.....	10
4.3 SPI Dual Supply Connection	11
4.4 SPI Single Supply connection.....	11
5 BASIC DEVICE OPERATION	12
5.1 Acceleration sensor	12
5.2 Power Management.....	12
5.3 Power On/Off Time	12
5.4 Communication Bus Interface I ² C and Its Addresses.....	13
6 MODES OF OPERATION	14
6.1 Modes Transition	14
6.2 Description of Modes.....	14
7 Functions and interrupts.....	15
7.1 STEP_INT.....	15
7.2 DRDY_INT.....	16
7.3 ANY_MOT_INT	16
7.4 SIG_MOT_INT.....	17
7.5 NO_MOT_INT	17
7.6 RAISE_INT	17
7.7 Interrupt configuration	18
8 I ² C COMMUNICATION PROTOCOL	19
8.1 I ² C Timings	19
8.2 I ² C R/W Operation.....	19
9 REGISTERS	21
9.1 Register Map.....	21
9.2 Register Definition.....	22

1 INTERNAL SCHEMATIC DIAGRAM

1.1 Internal Schematic Diagram

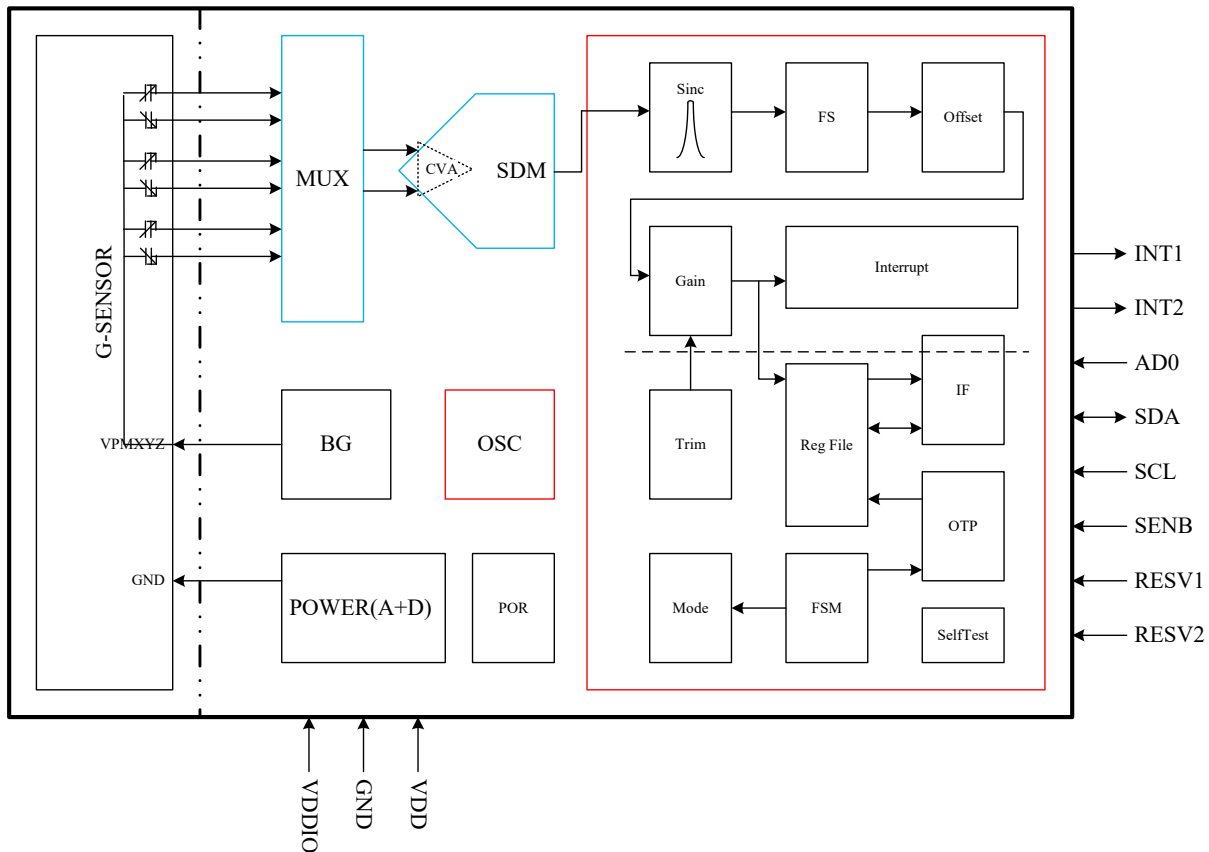

Figure 1. Block Diagram

Table 1. Block Function

Block	Function
Transducer	3-axis acceleration sensor
CVA	Charge-to-Voltage amplifier for sensor signals
Interrupt	Digital interrupt engine, to generate interrupt signal on data conversion, and motion function
FSM	Finite state machine, to control device in different mode
I ² C/SPI	Interface logic data I/O
OSC	Internal oscillator for internal operation
Power	Power block, including LDO

2 SPECIFICATIONS AND I/O CHARACTERISTICS

2.1 Product Specifications

Table 2. Specifications (* Tested and specified at 25°C and 3.0V VDD except stated otherwise.)

Parameter	Conditions	Min	Typ	Max	Unit
Supply voltage VDD	VDD, for internal blocks	1.71	3.3	3.6	V
I/O voltage VDDIO	VDDIO, for IO only	1.71	3.3	VDD	V
Standby current	VDD and VDDIO on		1		μA
Low power current	ODR=268 Hz		50		μA
	ODR=134 Hz		25.3		
	ODR=67 Hz		12.9		
	ODR=33.6 Hz		6.7		
	ODR=13.4 Hz		2.9		
	ODR=6.7 Hz		1.7		
Low noise current	ODR=32.5 Hz		100		μA
	ODR=21.6 Hz		83.3		
	ODR=13 Hz		50		
	ODR=6.5 Hz		25		
BW	Programmable bandwidth		0.16~168		Hz
Data output rate (ODR)	2*BW		0.32~336		Samples /sec
Startup time	From the time when VDD reaches to 90% of final value to the time when device is ready for conversion		2		ms
Wakeup time	From the time device enters into active mode to the time device is ready for conversion		1		ms
Operating temperature		-40		85	°C
Acceleration Full Range			±2/±4/±8/ ±16/±32		g
Sensitivity	FS=±2g		4096		LSB/g
	FS=±4g		2048		
	FS=±8g		1024		
	FS=±16g		512		
	FS=±32g		256		
Sensitivity Temperature Drift	FS=±2g, Normal VDD Supplies		±0.02		%/°C
Sensitivity tolerance	Gain accuracy		±4		%
Zero-g offset	FS=±2g, Normal VDD Supplies		±80		mg
Zero-g offset Temperature Drift	FS=±2g, Normal VDD Supplies		±2		mg/°C
Noise density	FS=±2g, run state		200		μg/√Hz
Nonlinearity	FS=±2g, Best fit straight line,		±0.5		%FS
Cross Axis Sensitivity			1		%

2.2 Absolute Maximum Ratings

Table 3. Absolute Maximum Ratings (Tested at 25°C except stated otherwise.)

Parameters	Condition	Min	Max	Units
VDD		-0.3	5.4	V
VDDIO		-0.3	5.4	V
ESD	HBM		2	kV
Shock Immunity	Duration < 200μs		10000	g
Storage temperature		-50	150	°C

2.3 I/O Characteristics

Table 4. I/O Characteristics

Parameter	Symbol	Pin	Condition	Min.	TYP.	Max.	Unit
Voltage Input High Level 1	V_{IH1}	SDA, SCL		$0.7 \cdot V_{DDI}$ 0		$V_{DDIO} + 0.3$	V
Voltage Input Low Level 1	V_{IL1}	SDA, SCL		-0.3		$0.3 \cdot V_{DDI}$ 0	V
Voltage Output High Level	V_{OH}	INT1, INT2	Output Current $\geq -100\mu A$	$0.8 \cdot V_{DDI}$ 0			V
Voltage Output Low Level	V_{OL}	INT1, INT2, SDA	Output Current $\leq 100\mu A$ (INT) Output Current $\leq 1mA$ (SDA)			$0.2 \cdot V_{DDI}$ 0	V

3 PACKAGE PIN CONFIGURATIONS

3.1 Package 3-D View

Arrow indicates direction of g field that generates a positive output reading in normal measurement configuration.

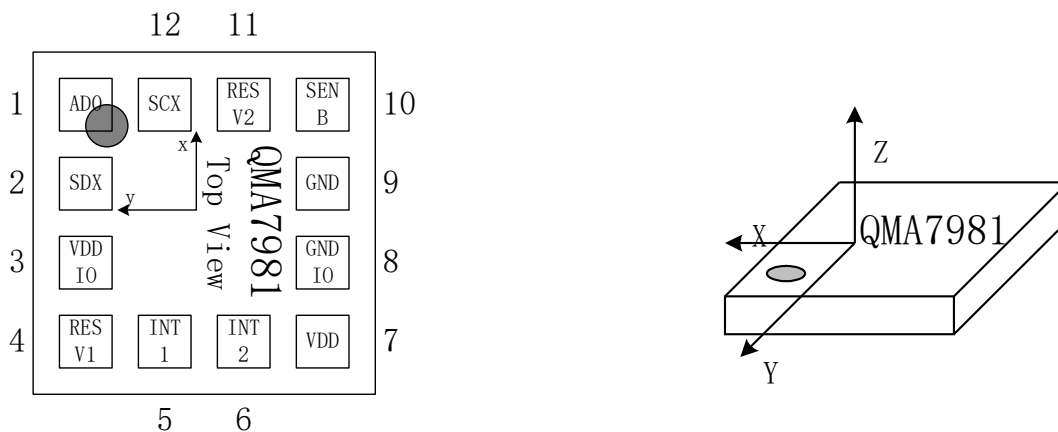

Figure 2. Package View

Table 5. Pin Configurations

PIN No.	PIN NAME	I/O	Power Supply	TYPE	Function
1	AD0	I	VDDIO	CMOS	LSB of I ² C address, or SDO of 4W SPI
2	SDX	IO	VDDIO	CMOS	Serial data for I ² C, or SDI of 4W SPI, or SDIO of 3W SPI
3	VDDIO	P	VDDIO	Power	Power supply to digital interface
4	RESV1	I	VDDIO	CMOS	Reserved. Float or connect to GND
5	INT1	O	VDDIO	CMOS	Interrupt 1
6	INT2	O	VDDIO	CMOS	Interrupt 2
7	VDD	P	VDD	Power	Power supply to internal block
8	GNDIO	G	GND	Power	Ground to digital interface
9	GND	G	GND	Power	Ground to internal block
10	SENB	IO	VDDIO	CMOS	Protocol selection
11	RESV2	IO	VDDIO	CMOS	Reserved. Float, or connect to GND
12	SCL	I	VDDIO	CMOS	Serial clock for I ² C, or Serial clock for SPI

3.2 Package Outlines

3.2.1 Package Type
LGA (Land Grid Array)

3.2.2 Package Outline Drawing:
2.0mm (Length)*2.0mm (Width)*0.95mm (Height)

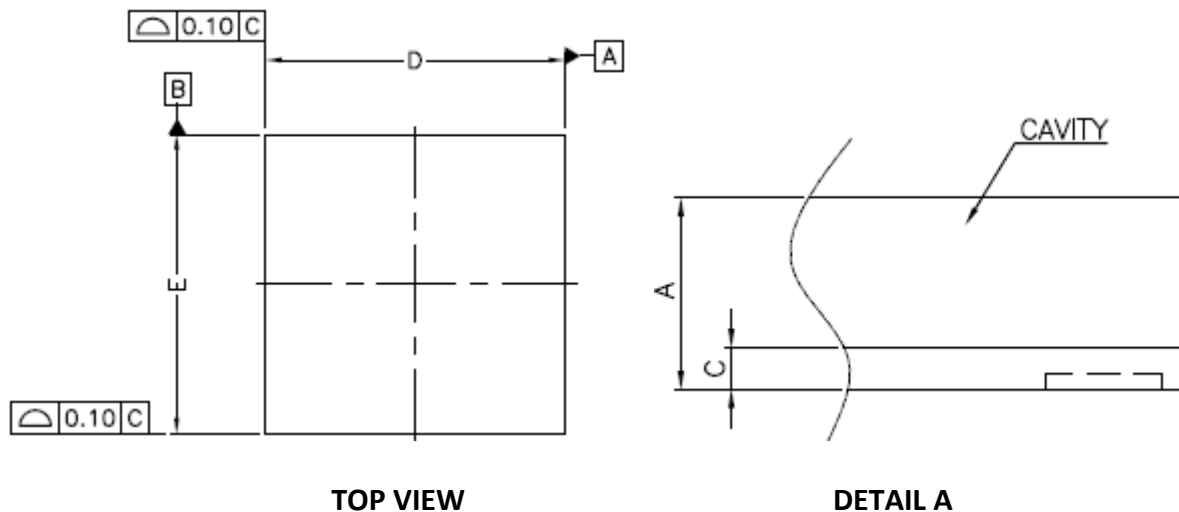

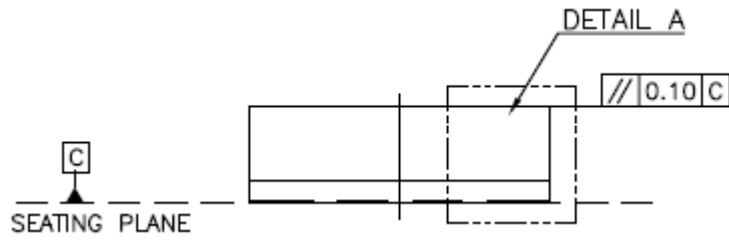
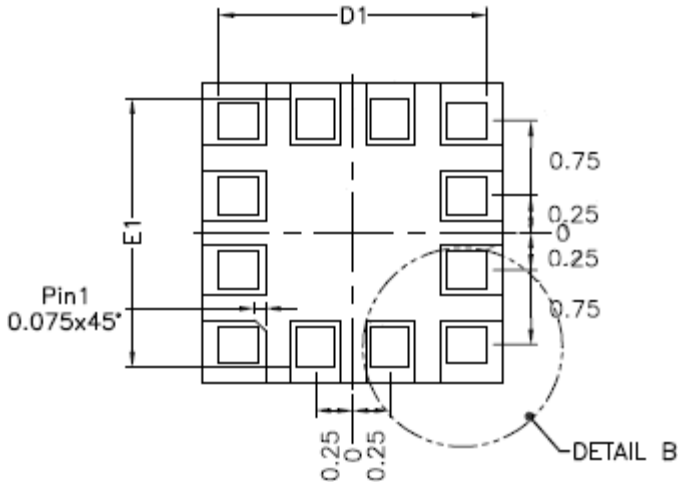
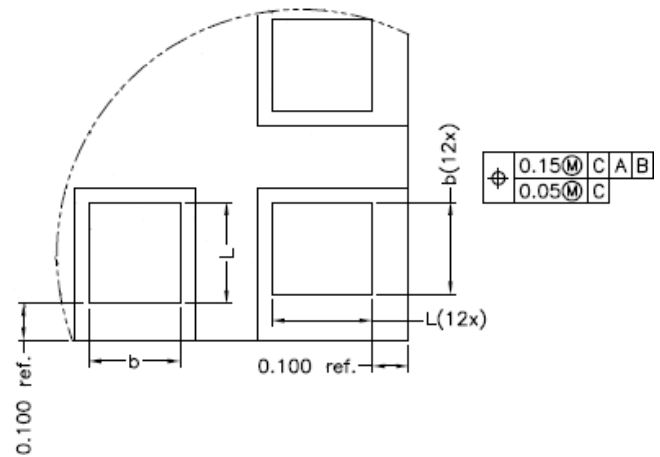
SIDE VIEW

BOTTOM VIEW

DETAIL B

SYMBOL	DIMENSION (MM)			DIMENSION (inch)		
	MIN.	NOM.	MAX.	MIN.	NOM.	MAX.
A	0.90	0.95	1.00	0.035	0.037	0.039
C	0.16	0.20	0.24	0.006	0.008	0.009
b	0.20	0.25	0.30	0.008	0.010	0.012
D	1.95	2.00	2.05	0.077	0.079	0.081
D1	1.80 BSC			0.071 BSC		
E	1.95	2.00	2.05	0.077	0.079	0.081
E1	1.80 BSC			0.071 BSC		
L	0.225	0.275	0.325	0.010	0.012	0.014

NOTE:

1. CONTROLLING DIMENSION: MILLIMETER.

Figure 3. Package Outline Drawing

3.2.3 Marking:

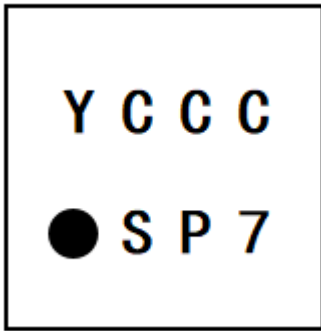

Figure 4. Marking Format

Marking Text	Description	Comments
Line 1	Y: year code CCC: lot code	year code: 1 character Lot code: 3 alphanumeric digits, variable to generate mass production trace-code
Line 2	S: Sub-con ID P: Part number 7: Fixed number	S: 1 alphanumeric digit, variable identify sub-con P: 1 alphanumeric digit, variable to identify part number 7: "7" stand for product name QMA7981
●	Pin 1 identifier	--

4 EXTERNAL CONNECTION

4.1 I2C Dual Supply Connection

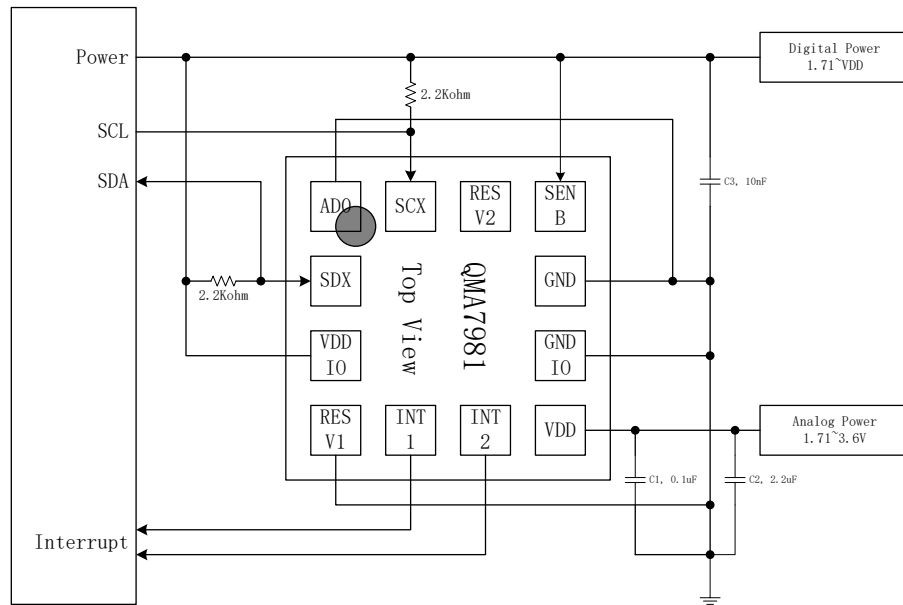

Figure 5. I2C Dual Supply Connection

4.2 I2C Single Supply connection

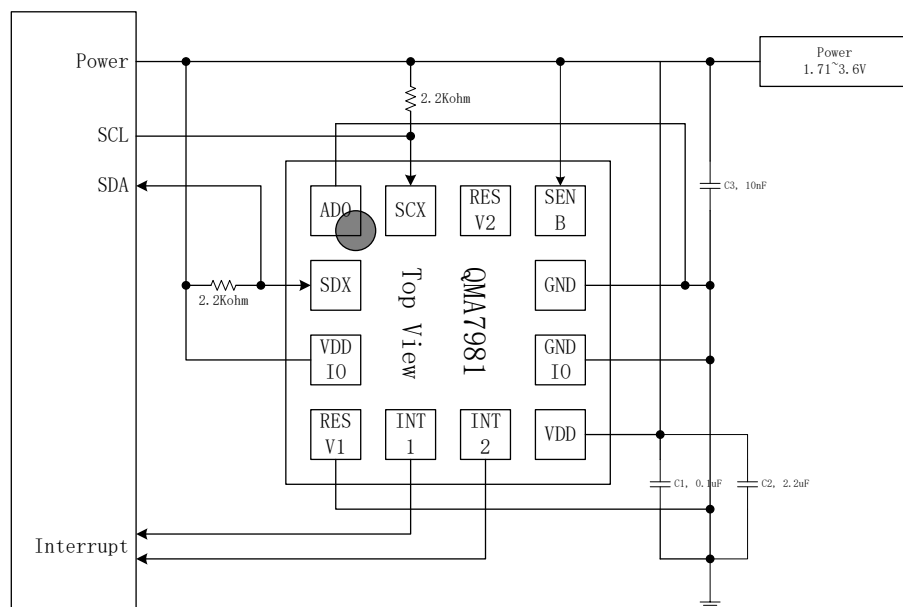

Figure 6. I2C Single Supply Connection

4.3 SPI Dual Supply Connection

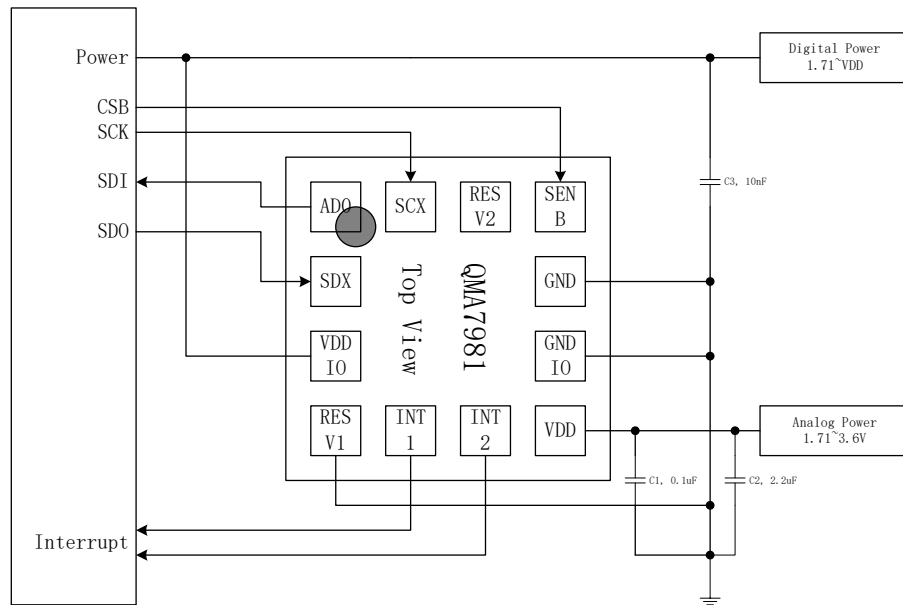

Figure 7. SPI Dual Supply Connection

4.4 SPI Single Supply connection

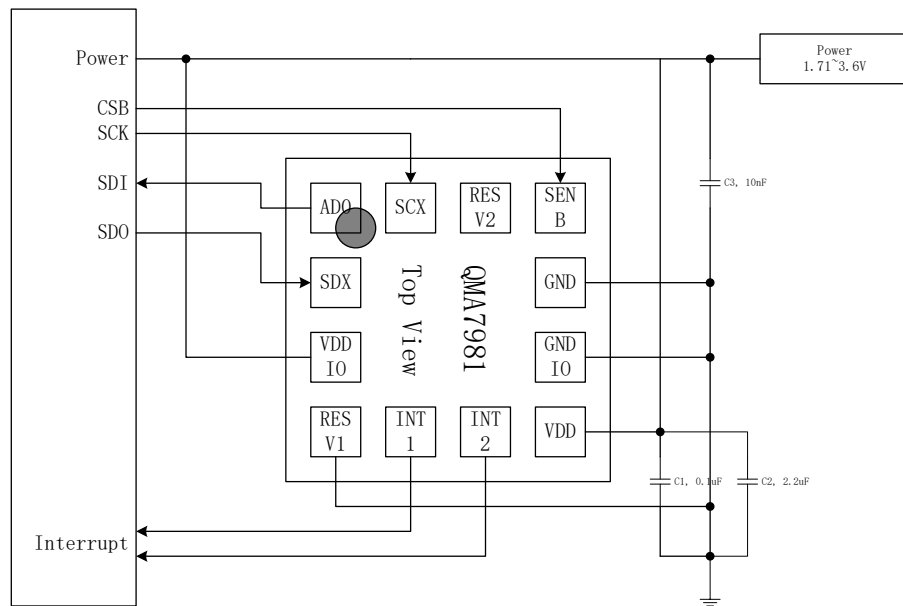

Figure 8. SPI Single Supply Connection

5 BASIC DEVICE OPERATION

5.1 Acceleration sensor

The QMA7981 acceleration sensor circuit consists of tri-axial sensors and application specific support circuits to measure the acceleration of device. When a DC power supply is applied to the sensor, the sensor converts any accelerating incident in the sensitive axis directions to charge output.

5.2 Power Management

Device has two power supply pins. VDD is the main power supply for all of the internal blocks, including analog and digital. VDDIO is a separate power supply, for digital interface only.

The device contains a power-on-reset generator. It generates reset pulse as power on, which can load the register's default value, for the device to function properly.

To make sure the POR block functions well, we should have such constrains on the timing of VDD and VDDIO.

The device should turn-on both power pins in order to operate properly. When the device is powered on, all registers are reset by POR, then the device transits to the standby mode and waits for further commends.

Table 6 provides references for four power states.

Table 6. Power States

Power State	VDD	VDDIO	Power State description
1	0V	0V	Device Off, No Power Consumption
2	0V	1.71v~3.6v	Not allowed. User need to make sure that VDDIO is less than VDD. Otherwise, there will be leakage from VDDIO to VDD through internal ESD devices
3	1.71v~3.6v	0V	Device Off, Same Current as Standby Mode
4	1.71v~3.6v	1.71v~VDD	Device On, Normal Operation Mode, Enters Standby Mode after POR

5.3 Power On/Off Time

Device has two power supply pins and two ground pins. VDD is the main power supply for all of the internal blocks, including analog and digital. VDDIO is a separate power supply, for digital interface only. GND is 0V supply for all of internal blocks, and GNDIO for digital interface.

There is no limitation on the voltage levels of VDD and VDDIO relative to each other, as long as they are within operating range.

The device contains a power-on-reset generator. It generates reset pulse as power on, which can load the register's default value, for the device to function properly.

To make sure the POR block functions well, we should have such constrains on the timing of VDD. The power on/off time related to the device is in Table 7

Table 7. Time Required for Power On/Off

Parameter	Symbol	Condition	Min.	Typ.	Max.	Unit
POR Completion Time	PORT	Time Period After VDD and VDDIO at Operating Voltage to Ready for I ² C Command and Analogy Measurement.			250	μs
Power off Voltage	SDV	Voltage that Device Considers to be Power Down.			0.2	V
Power on Interval	PINT	Time Period Required for Voltage Lower Than SDV to Enable Next POR	100			μs
Power on Time	PSUP	Time Period Required for Voltage from SDV to 90% of final value			50	ms

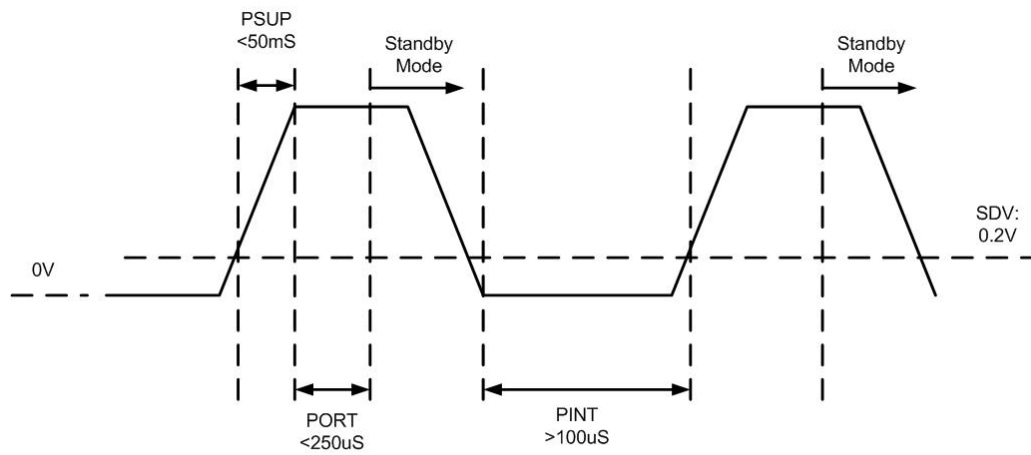

Power On/Off Timing

Figure 9. Power On/Off Timing

5.4 Communication Bus Interface I²C and Its Addresses

This device will be connected to a serial interface bus as a slave device under the control of a master device, such as the processor. Control of this device is carried out via I²C.

This device is compliant with I²C -Bus Specification, document number: 9398 393 40011. As an I²C compatible device, this device has a 7-bit serial address and supports I²C protocols. This device supports standard and fast speed modes, 100 kHz and 400 kHz, respectively. External pull-up resistors are required to support all these modes.

There are two I²C addresses selected by connecting pin 1 (AD0) to GND or VDDIO. The first six MSB are hardware configured to "001001" and the LSB can be configured by AD0.

Table 8. I²C Address Options

AD0 (pin 1)	I ² C Slave Address(HEX)	I ² C Slave Address(BIN)
Connect to GND	12	0010010
Connect to VDDIO	13	0010011

6 MODES OF OPERATION

6.1 Modes Transition

QMA7981 has two different operational modes, controlled by register (0x11), MODE_BIT. The main purpose of these modes is for power management. The modes can be transitioned from one to another, as shown below, through I²C commands. The default mode after power-on is standby mode.

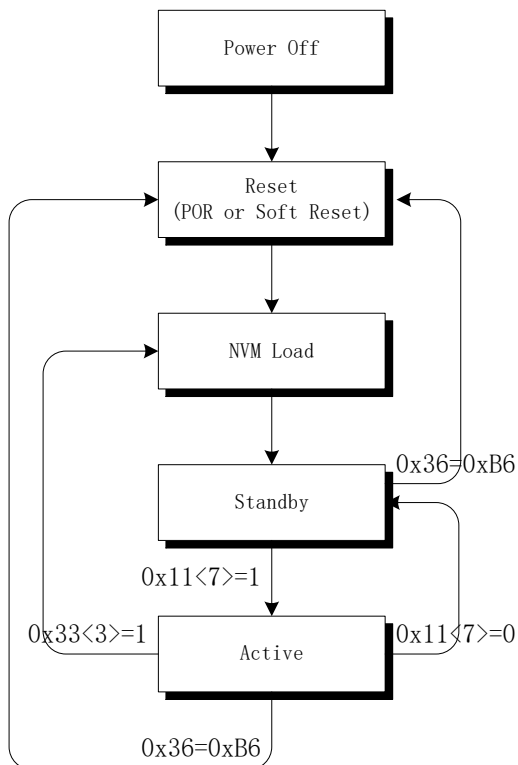

Figure 10. Basic operation flow after power-on

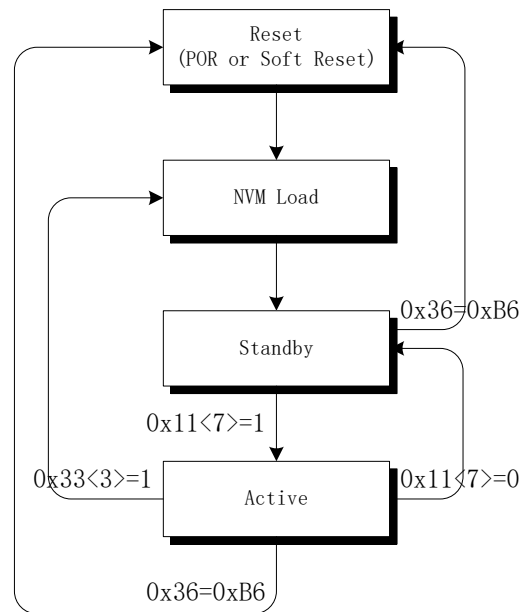

Figure 11. The work mode transferring

The default mode after power on is standby mode. Through I²C instruction, device can switch between standby mode and active mode. With SOFTRESET by writing 0xB6 into register 0x36, all of the registers will get default values. SOFTRESET can be done both in active mode and in standby mode. Also, by writing 1 in NVM_LOAD (0x33<3>) when device is in active mode, the NVM related image registers will get default value from NVM, however, other registers will keep the values of their own.

6.2 Description of Modes

6.2.1 Active Mode

In active mode, the ADC digitizes the charge signals from transducer, and digital signal processor conditions these signals in digital domain, processes the interrupts, and send data to Data registers (0x01~0x06).

6.2.2 Standby Mode

In standby mode, most of the blocks are off, while device is ready for access through I²C. Standby mode is the default mode after power on or soft reset. Device can enter into this mode by set the soft reset register (0x36) to 0xB6 or set the MODE_BIT (0x11<7>) to logic 0.

Besides the above two modes, the device also contains NVM loading state. This state is used to reset the value of the NVM related image registers. There are two bits related to this state. When NVM_LOAD (0x33<3>) is set to 1, NVM loading starts. When the device is in NVM loading state, NVM_RDY (0x33<2>) is set to logic 0 by device. After NVM loading is finished, NVM_RDY (0x33<2>) is set back to logic 1 by device, and NVM_LOAD is reset to 0 by device automatically. NVM loading can only happen when NVM_LOAD is set to 1 in active mode. If the user sets this NVM_LOAD bit to 1 in standby mode, the device will not take the action until it enters into active state by setting MODE_BIT (0x11<7>) to logic 1.

After loading NVM, the device will enter into standby mode directly.

The loading time for NVM is about 100uS.

7 Functions and interrupts

ASIC support interrupts, such as STEP_INT, DRDY_INT, ANY_MOT_INT, SIG_MOT_INT, NO_MOT_INT, RAISE_INT, etc.

7.1 STEP_INT

The STEP/STEP_QUIT detect that the user is entering/exiting step mode. When the user enter into step mode, at least one axis sensor data will vary periodically, by numbering the variation periods the step counter can be calculated.

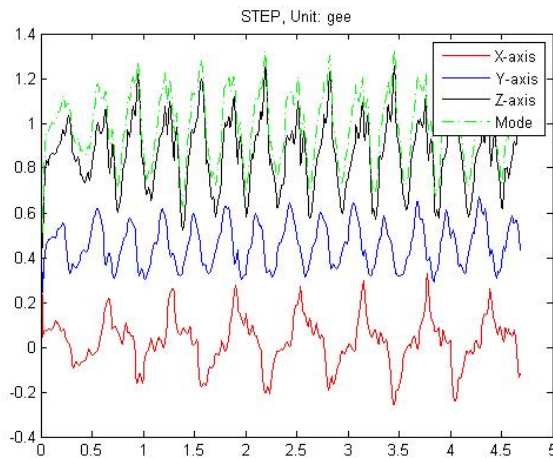

Figure 10. STEP/STEP_QUIT

Median data (max+min) / 2 is called dynamic threshold, the max and min data can be updated by certainly samples, the sample number can be set by register STEP_SAMPLE_CNT (0x12<6:0>). When the sensor data decreasing (or increasing) through the dynamic threshold, a user run step is detected.

Register STEP_PRECISION (0x13<6:0>) is used as threshold when updating the new collected sensor data. Sensor data below the threshold will be discarded, this helps removing unstable variations causing failed detection.

The run step event happened at certain interval timing. All of the events outside the timing window will not be regarded as a run step and the step counter will not counted. The timing window can be set by register STEP_TIME_UP(0x15) and



STEP_TIME_LOW(0x14), the conversion ODR numbers ranged from STEP_TIME_LOW *ODR to 8* STEP_TIME_UP*ODR .

STEP_COUNT_PEAK<2:0> is used to set a fixed peak value for step detection, 0.05G~0.4G can be set. STEP_COUNT_P2P<2:0> is used to set a peak to peak threshold for step detection, 0.3G~1G can be set.

To remove unstable variation which will cause false STEP event detection, the step counter considers steps as valid step events only after some continuous steps detected; the start threshold can be set by 0x1F<7:5>. Also, the step counter register STEP_CNT<23:0> ({0x0E,0x08,0x07}) will be updated immediately by the setting number, and interrupt STEP is also generated.

The related interrupt status bit is STEP_INT (0x0A<3>) and SIG_STEP (0x0A<6>). When the interrupt is generated, the value of STEP_INT will be set to logic 1, which will be cleared after the interrupt status register is read by user.

STEP_IEN/SIG_STEP_IEN (0x16<3>/0x16<6>) is the enable bit for the STEP_INT/SIG_STEP_INT. Also, to get this interrupt on PIN_INT1 and/or PIN_INT2, we need to set INT1_STEP (0x19<3>)/INT1_SIG_STEP (0x19<6>) or INT2_STEP (0x1B<3>)/INT2_SIG_STEP (0x1B<6>) to logic 1, to map the internal interrupt to the interrupt PINs.

7.2 DRDY_INT

The width of the acceleration data is 14 bits, in two’s complement representation. The data of each axis is split into 2 parts, the MSB part (one byte contains bit 13 to bit 6) and the LSB part (one byte contains bit 5 to bit 0). Reading data should start with LSB part. When user is reading the LSB byte of data, to ensure the integrity of the acceleration data, the content of MSB can be locked, by setting SHADOW_DIS (0x21<6>) to logic 0. This lock function can be disabled by setting SHADOW_DIS to logic 1. Without lock, the MSB and LSB content will be updated by new value immediately. The bit NEW_DATA in the LSB byte is the flag of the new data. If new data is updated, this NEW_DATA flag will be 1, and will be cleared when corresponding MSB or LSB is read by user.

Also, the user should note that even with SHADOW_DIS=0, the data of 3 axes are not guaranteed from the same time point.

The device supports four different acceleration measurement ranges. The range is setting through RANGE (0x0F<3:0>), and the details as following:

RANGE	Acceleration range	Resolution
0001	2g	244ug/LSB
0010	4g	488ug/LSB
0100	8g	977ug/LSB
1000	16g	1.95mg/LSB
1111	32g	3.91mg/LSB
Others	2g	244ug/LSB

The interrupt for the new data serves for the synchronous data reading for the host. It is generated after storing a new value of z-axis acceleration data into data register. This interrupt will be cleared automatically when the next data conversion cycle starts, and the interrupt will be effective about 64*MCLK, and automatically cleared. The interrupt mode for the new data is fixed to be non-latched.

7.3 ANY_MOT_INT

Any motion Any motion detection uses slope between two successive data to detect the changes in motion. It generates interrupt when a preset threshold ANY_MOT_TH (0x2E) is exceeded.

The time difference between two successive data depends on the output data rate (ODR).

$$\text{Slope}(t1) = (\text{acc}(t1) - \text{acc}(t0)) * \text{ODR}$$

The any motion detection criteria are fulfilled and interrupt is generated if any of enabled channels exceeds ANY_MOT_TH for ANY_MOT_DUR (0x2C<1:0>) consecutive times.

As long as all the enabled channels data fall or stay below ANY_MOT_TH for ANY_MOT_DUR consecutive times, the interrupt will be reset unless the interrupt signal is latched.

The any motion detection engine will send out the signals of axis which triggered the interrupt (ANY_MOT_FIRST_X (0x09<0>), ANY_MOT_FIRST_Y (0x09<1>), ANY_MOT_FIRST_Z (0x09<2>)) and the sign of the motion (ANY_MOT_SIGN (0x09<3>))

7.4 SIG_MOT_INT

A significant motion is a motion due to a change in user location.

The algorithm is as following:

- 1) Look for movement, same setting as any motion detection
- 2) If movement detected, sleep for T_Skip (0x2F<3:2>)
- 3) Look for movement
 - a) If no movement detected within T_Proof (0x2F<5:4>), go back to 1
 - b) If movement detected, report a significant movement, and generate the interrupt

The significant motion detection and any motion detection are exclusive, user can select either one through SIG_MOT_SEL (0x2F<0>).

If significant motion is detected, the engine will set SIG_MOT_INT (0x0A<0>).

7.5 NO_MOT_INT

No-motion interrupt is generated if the slope (absolute value of acceleration difference) on all selected axes is smaller than the programmable threshold for a programmable time. Figure shows the timing for the no-motion interrupt. Register (0x2C) NO_MOT_DUR defines the delay times before the no-motion interrupt is generated. Table lists the delay times adjustable with register (0x2C) NO_MOT_DUR.

The no-motion interrupt is enabled per axis by writing logic 1 to bits (0x18) NO_MOTION_EN_X, (0x18) NO_MOTION_EN_Y, and (0x18) NO_MOTION_EN_Z, respectively. The no-motion threshold is set through the (0x2D) NO_MOT_TH register. The meaning of an LSB of (0x2D) NO_MOT_TH depends on the selected g-range: it corresponds to 3.91mg in 2g-range (7.81mg in 4g-range, 15.6mg in 8g-range, 31.25mg in 16g-range, 62.5mg in 32g-range). Therefore the maximum value is 996mg in 2g-range (2g in 4g-range, 4g in 8g-range, 8g in 16g-range, and 16g in 32g-range). The time difference between the successive acceleration samples depends on the selected ODR and equates to 1/ODR.

7.6 RAISE_INT

Raise wake algorithm is used to detect the action of raise hand (or hand down). The interrupt is enabled by writing logic 1 to bits (0x16[1]) RAISE_EN, (0x16[2]) HD_EN. User can adjust the sensitivity through the registers. The register RAISE_WAKE_SUM_TH(0x2A[5:0]) defines the strength of hand action (raise and down). The register RAISE_DIFF_TH(0x2A[7:6], 0x2B[1:0]) defines the differential values of twice actions, when the hand behavior almost done the differential value will be smaller and we can use this register to set the threshold. RAISE_WAKE_PERIOD and RAISE_WAKE_TIMEOUT_TH define the duration of the total hand action.

7.7 Interrupt configuration

The device has the above 3 interrupt engines. Each of the interrupts can be enabled and configured independently. If the trigger condition of the enabled interrupt fulfilled, the corresponding interrupt status bit will be set to logic 1, and the mapped interrupt pin will be activated. The device has two interrupt PINs, INT1 and INT2. Each of the interrupts can be mapped to either PIN or both PINs.

The interrupt status registers INT_ST(0x09~0x0d) will update when a new data word is written into the data registers. If an interrupt is disabled, the related active interrupt status bit is disabled immediately.

When interrupt condition is fulfilled, related bit of interrupt will be set, until the associated interrupt condition is no more valid. Read operation to related register will also clear the register.

Device supports 2 interrupt modes, non-latched, and latched mode. The interrupt modes are set through LATCH_INT (0x21<0>).

In non-latched mode, the mapped interrupt pin will be set and/or cleared same as associated interrupt register bit. Also, the mapped interrupt pin can be cleared with read operation to any of the INT_ST(0x09~0x0d).

Exception to this is the new data interrupt and step interrupt, which are automatically reset after a fixed time ($T_{Pulse} = 64/MCLK$), no matter LATCH_INT (0x21<0>) is set to 0 or 1.

In latched mode, the clearings of mapped pins are determined by INT_RD_CLR (0x21<7>).

If the condition for triggering the interrupt still holds, the interrupt status will be set again with the next change of the data registers.

Mapping the interrupt pins can be set by INT_MAP (0x19~0x1B).

The electrical interrupt pins can be set INT_PIN_CONF (0x20<3:0>). The active logic level can be set to 1 or 0, and the interrupt pin can be set to open-drain or push-pull.

8 I²C COMMUNICATION PROTOCOL

8.1 I²C Timings

Table 9 and Figure 11 describe the I²C communication protocol times

Table 9. I²C Timings

Parameter	Symbol	Condition	Min.	Typ.	Max.	Unit
SCL Clock	f_{scl}		0		400	kHz
SCL Low Period	t_{low}		1			μ s
SCL High Period	t_{high}		1			μ s
SDA Setup Time	t_{sdat}		0.1			μ s
SDA Hold Time	t_{hdat}		0		0.9	μ s
Start Hold Time	t_{hdsta}		0.6			μ s
Start Setup Time	t_{susta}		0.6			μ s
Stop Setup Time	t_{susto}		0.6			μ s
New Transmission Time	t_{buf}		1.3			μ s
Rise Time	t_r					μ s
Fall Time	t_f					μ s

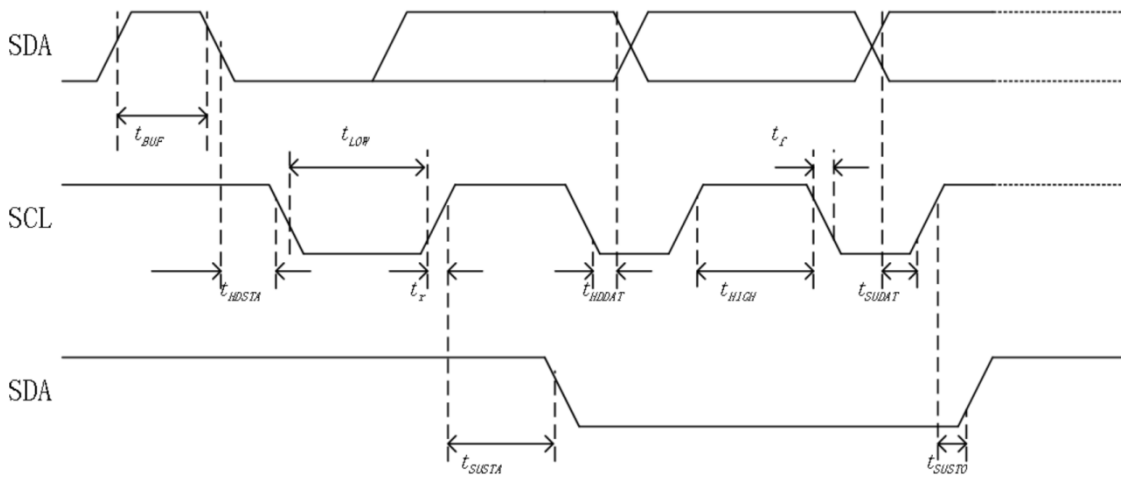

Figure 11. I²C Timing Diagram

8.2 I²C R/W Operation

8.2.1 Abbreviation

Table 10. Abbreviation

SACK	Acknowledged by slave
MACK	Acknowledged by master
NACK	Not acknowledged by master
RW	Read/Write

8.2.2 Start/Stop/Ack

START: Data transmission begins with a high to transition on SDA while SCL is held high. Once I²C transmission starts, the bus is considered busy.

STOP: STOP condition is a low to high transition on SDA line while SCL is held high.

ACK: Each byte of data transferred must be acknowledged. The transmitter must release the SDA line during the acknowledge pulse while the receiver must then pull the SDA line low so that it remains stable low during the high period of the acknowledge clock cycle.

NACK: If the receiver doesn't pull down the SDA line during the high period of the acknowledge clock cycle, it's recognized as NACK by the transmitter.

8.2.3 I²C Write

I²C write sequence begins with start condition generated by master followed by 7 bits slave address and a write bit (R/W=0). The slave sends an acknowledge bit (ACK=0) and releases the bus. The master sends the one byte register address. The slave again acknowledges the transmission and waits for 8 bits data which shall be written to the specified register address. After the slave acknowledges the data byte, the master generates a stop signal and terminates the writing protocol.

Table 11. I²C Write

START	Slave Address							R W	SACK	Register Address (0x11)							SACK	Data (0x80)								SACK	STOP
	0	0	1	0	0	1	0	0		0	0	0	1	0	0	0		1	1	0	0	0	0	0	0		

8.2.4 I²C Read

I²C write sequence consists of a one-byte I²C write phase followed by the I²C read phase. A start condition must be generated between two phase. The I²C write phase addresses the slave and sends the register address to be read. After slave acknowledges the transmission, the master generates again a start condition and sends the slave address together with a read bit (R/W=1). Then master releases the bus and waits for the data bytes to be read out from slave. After each data byte the master has to generate an acknowledge bit (ACK = 0) to enable further data transfer. A NACK from the master stops the data being transferred from the slave. The slave releases the bus so that the master can generate a STOP condition and terminate the transmission.

The register address is automatically incremented and more than one byte can be sequentially read out. Once a new data read transmission starts, the start address will be set to the register address specified in the current I²C write command.

Table 12. I²C Read

START	Slave Address							R W	SACK	Register Address (0x00)							SACK								
	0	0	1	0	0	1	0	0		0	0	0	0	0	0	0		0							
ST	Slave Address							R W	SA	Data (0x00)							M	Data (0x01)							

	0	0	1	0	0	1	0	1		0	0	0	0	0	0	1	0		0	0	0	0	0	0	0	0
MACK	Data (0x02)								MACK	Data (0x07)								MACK	STOP							
	0	0	0	0	0	0	1	0		0	0	0	0	0	0	0	0									

9 REGISTERS

9.1 Register Map

The table below provides a list of the 8-bit registers embedded in the device and their respective function and addresses

Table 13. Register Map

Add.	Name	bit7	bit6	bit5	bit4	bit3	bit2	bit1	bit0	R/W	DEF		
0x3F		RAISE_WAKE_PERIOD[10:8]				RAISE_WAKE_TIMEOUT_TH[11:8]				RW	02		
0x3E	RAISE_CFG	RAISE_WAKE_TIMEOUT_TH[7:0]										RW	00
0x36	S_RESET	SOFTRESET: 0xB6										RW	00
0x35		YZ_TH_SEL[2:0]					RAISE_WAKE_PERIOD[7:0]					RW	81
0x34							Y_TH[4:0]					RW	9D
0x32	ST	SELFTTEST_BIT					SELFTTEST_SIGN	BP_AXIS_STEP<1:0>			RW	00	
0x31										RW	00		
0x30	RST_MOT	MO_BP_CO	STEP_BP_CO		LOW_RST_N	HIGH_RST_N	NO_MOT_RST_N	SIG_MOT_RST_N	ANY_MOT_RST_N	RW	1F		
0x2F				SIG_MOT_TPROOF<1:0>		SIG_MOT_TSKIP<1:0>			SIG_MOT_SEL	RW	00		
0x2E		ANY_MOT_TH<7:0>										RW	00
0x2D		NO_MOT_TH<7:0>										RW	00
0x2C	MOT_CFG	NO_MOT_DUR<5:0>					ANY_MOT_DUR<1:0>					RW	00
0x2B		HD_Z_TH[2:0]			HD_X_TH[2:0]			RAISE_WAKE_DIFF_TH[3:2]			RW	7C	
0x2A	RAISE_CFG	RAISE_WAKE_DIFF_TH[1:0]			RAISE_WAKE_SUM_TH[5:0]					RW	D8		
0x29		OS_CUST_Z<7:0>										RW	00
0x28		OS_CUST_Y<7:0>										RW	00
0x27	OS_CUST	OS_CUST_X<7:0>										RW	00
0x21	INT_CFG	INT_RD_CLR	SHADOW_DIS	DIS_I2C	1	1	1	LATCH_INT_STEP	LATCH_INT	RW	1C		
0x20	INT_PIN_CFG	DIS_PU_SENB	DIS_IE_ADO	EN_SPI3W	STEP_COUNT_PEAK<2>	INT2_OD	INT2_LVL	INT1_OD	INT1_LVL	RW	05		
0x1F		STEP_START_CNT<2:0>			STEP_COUNT_PEAK<1:0>		STEP_COUNT_P2P<2:0>				RW	A9	
0x1E		Z_TH[3:0]				X_TH[3:0]				RW	66		
0x1D	STEP_CFG	STEP_INTERVAL<6:0>							EN_RESET_DC		RW	00	
0x1C		INT2_NO_MOT	1	1	INT2_DATA	INT2_LOW	INT2_HIGH	1	INT2_ANY_MOT	RW	62		
0x1B		1	INT2_SIG_STEP	1	1	INT2_STEP	INT2_HD	INT2_RAISE	INT2_SIG_MOT	RW	B0		
0x1A		INT1_NO_MOT	1	1	INT1_DATA	INT1_LOW	INT1_HIGH	1	INT1_ANY_MOT	RW	62		
0x19	INT_MAP	1	INT1_SIG_STEP	1	1	INT1_STEP	INT1_HD	INT1_RAISE	INT1_SIG_MOT	RW	B0		
0x18		NO_MOT_EN_Z	NO_MOT_EN_Y	NO_MOT_EN_X	1	1	ANY_MOT_EN_Z	ANY_MOT_EN_Y	ANY_MOT_EN_X	RW	18		
0x17		1	1	1	INT_DATA_EN	LOW_EN	HIGH_EN_Z	HIGH_EN_Y	HIGH_EN_X	RW	E0		
0x16	INT_EN	1	SIG_STEP_IEN	1	1	STEP_IEN	HD_EN	RAISE_EN	1	RW	B1		
0x15		STEP_TIME_LOW<7:0>										RW	00
0x14		STEP_TIME_LOW<7:0>										RW	19
0x13		STEP_CLR	STEP_PRECISION<6:0>								RW	7F	
0x12	STEP_CFG	STEP_EN	STEP_SAMPLE_CNT<6:0>								RW	14	
0x11	PM	MODE_BIT	1	T_RSTB_SINC_SEL<1:0>			MCLK_SEL<3:0>			RW	40		
0x10	BW	1	1	1	BW<4:0>						RW	E0	
0x0F	FSR	1	1	1	1	RANGE<3:0>					RW	F0	
0x0E	STEP_CNT	STEP_CNT<23:16>										R	00
0x0D										R	00		
0x0C					HIGH_INT	HIGH_SIGN	HIGH_FIRST_Z	HIGH_FIRST_Y	HIGH_FIRST_X	R	00		
0x0B					DATA_INT	LOW_INT				R	00		
0x0A			SIG_STEP			STEP_INT	HD_INT	RAISE_INT	SIG_MOT_INT	R	00		
0x09	INT_ST	NO_MOT				ANY_MOT_SIGN	ANY_MOT_FIRST_Z	ANY_MOT_FIRST_Y	ANY_MOT_FIRST_X	R	00		
0x08		STEP_CNT<15:8>										R	00
0x07	STEP_CNT	STEP_CNT<7:0>										R	00
0x06		ACC_Z<13:6>										R	00
0x05		ACC_Z<5:0>					NEWDATA_Z					R	00
0x04		ACC_Y<13:6>										R	00
0x03		ACC_Y<5:0>					NEWDATA_Y					R	00
0x02		ACC_X<13:6>										R	00
0x01	DATA	ACC_X<5:0>					NEWDATA_X					R	00
0x00	CHIP ID	CHIP ID to indicate the product version										R	ANA

9.2 Register Definition

Register 0x00 (CHIP_ID)

Bit7	Bit6	Bit5	Bit4	Bit3	Bit2	Bit1	Bit0	R/W	Default
CHIP_ID<7:0>								RW	0xEX

This register is used to identify the device

Register 0x01 ~ 0x02 (DXL, DXM)

Bit7	Bit6	Bit5	Bit4	Bit3	Bit2	Bit1	Bit0	R/W	Default
DX<5:0>							NEWDATA _X	R	0x00
DX<13:6>								R	0x00

DX: 14bits acceleration data of x-channel. This data is in two's complement.
 NEWDATA_X: 1, acceleration data of x-channel has been updated since last reading
 0, acceleration data of x-channel has not been updated since last reading

Register 0x03 ~ 0x04 (DYL, DYM)

Bit7	Bit6	Bit5	Bit4	Bit3	Bit2	Bit1	Bit0	R/W	Default
DY<5:0>							NEWDATA _Y	R	0x00
DY<13:6>								R	0x00

DY: 14bits acceleration data of y-channel. This data is in two's complement.
 NEWDATA_Y: 1, acceleration data of y-channel has been updated since last reading
 0, acceleration data of y-channel has not been updated since last reading

Register 0x05 ~ 0x06 (DZL, DZM)

Bit7	Bit6	Bit5	Bit4	Bit3	Bit2	Bit1	Bit0	R/W	Default
DZ<5:0>							NEWDATA _Z	R	0x00
DZ<13:6>								R	0x00

DZ: 14bits acceleration data of z-channel. This data is in two's complement.
 NEWDATA_Z: 1, acceleration data of z-channel has been updated since last reading
 0, acceleration data of z-channel has not been updated since last reading

Register 0x07 ~ 0x08 (STEP_CNT)

Bit7	Bit6	Bit5	Bit4	Bit3	Bit2	Bit1	Bit0	R/W	Default
STEP_CNT<7:0>								R	0x00
STEP_CNT<15:8>								R	0x00

STEP_CNT<15:0>: 16 bits of step counter, out of total 24bits data. The MSB data are in 0x0e

Register 0x09 (INT_ST0)

Bit7	Bit6	Bit5	Bit4	Bit3	Bit2	Bit1	Bit0	R/W	Default
NO_MOT	SIG_STEP			ANY_MOT _SIGN	ANY_MOT _FIRST_Z	ANY_MOT _FIRST_Y	ANY_MOT _FIRST_X	R	0x00

NO_MOT: 1, no_motion interrupt active
 0, no_motion interrupt inactive

ANY_MOT_SIGN: 1, sign of any_motion triggering signal is negative
 0, sign of any_motion triggering signal is positive

ANY_MOT_FIRST_Z: 1, any_motion interrupt is triggered by Z axis
 0, any_motion interrupt is not triggered by Z axis

ANY_MOT_FIRST_Y: 1, any_motion interrupt is triggered by Y axis
 0, any_motion interrupt is not triggered by Y axis

ANY_MOT_FIRST_X: 1, any_motion interrupt is triggered by X axis
 0, any_motion interrupt is not triggered by X axis

Register 0x0a (INT_ST1)



Bit7	Bit6	Bit5	Bit4	Bit3	Bit2	Bit1	Bit0	R/W	Default
	SIG_STEP			STEP_INT	HD_INT	RAISE_INT	SIG_MOT_INT	R	0x00

SIG_STEP: 1, significant step is active
0, significant step is inactive

STEP_INT: 1, step valid interrupt is active
0, step quit interrupt is inactive

HD_INT: 1, hand down interrupt is active
0, hand down interrupt is inactive

RAISE_INT: 1, raise hand interrupt is active
0, raise hand interrupt is inactive

SIG_MOT_INT: 1, significant interrupt is active
0, significant interrupt is inactive

Register 0x0b (INT_ST2)

Bit7	Bit6	Bit5	Bit4	Bit3	Bit2	Bit1	Bit0	R/W	Default
			DATA_INT					R	0x00

DATA_INT: 1, data ready interrupt active
0, data ready interrupt inactive

Register 0x0e (STEP_CNT)

Bit7	Bit6	Bit5	Bit4	Bit3	Bit2	Bit1	Bit0	R/W	Default
STEP_CNT<23:16>								R	0x00

STEP_CNT<23:16>: 8bit MSB data of step counter, out of total 24bits data. The LSB data are in 0x07 and 0x08

Register 0x0f (FSR)

Bit7	Bit6	Bit5	Bit4	Bit3	Bit2	Bit1	Bit0	R/W	Default
1	1	1		RANGE<3:0>				RW	0xF0

RANGE<3:0>: set the full scale of the accelerometer. Setting as following

RANGE<3:0>	Acceleration range	Resolution
0001	2g	244ug/LSB
0010	4g	488g/LSB
0100	8g	977ug/LSB
1000	16g	1.95mg/LSB
1111	32g	3.91mg/LSB
Others	2g	244ug/LSB

Register 0x10 (BW)

Bit7	Bit6	Bit5	Bit4	Bit3	Bit2	Bit1	Bit0	R/W	Default
1	1	1	BW<4:0>					RW	0xE0

BW<4:0>: bandwidth setting, as following

BW<4:0>	ODR
xx000	MCLK/7695
xx001	MCLK/3855
xx010	MCLK/1935
xx011	MCLK/975
xx100	
xx101	MCLK/15375
xx110	MCLK/30735
xx111	MCLK/61455
Others	MCLK/7695

Register 0x11 (PM)

Bit7	Bit6	Bit5	Bit4	Bit3	Bit2	Bit1	Bit0	R/W	Default
MODE_BIT	1	T_RSTB_SINC_SEL<1:0>		MCLK_SEL<3:0>				RW	0x40

MODE_BIT: 1, set device into active mode
0, set device into standby mode

T_RSTB_SINC_SEL<1:0>: Reset clock setting. The preset time is reserved for CIC filter in digital

- 11, T_RSTB_SINC=8*MCLK
- 10, T_RSTB_SINC=6*MCLK
- 01, T_RSTB_SINC=4*MCLK
- 00, T_RSTB_SINC=3*MCLK

MCLK_SEL<3:0>: set the master clock to digital

MCLK_SEL<3:0>	Freq of MCLK
0000	500KHz
0001	333KHz
0010	200KHz
0011	100KHz
0100	50KHz
0101	25KHz
0110	12.5KHz
0111	5KHz
1xxx	Reserved

Register 0x12 (STEP_CONF0)

Bit7	Bit6	Bit5	Bit4	Bit3	Bit2	Bit1	Bit0	R/W	Default
STEP_EN	STEP_SAMPLE_CNT<6:0>						RW	0x14	

STEP_EN: enable step counter, this bit should be set when using step counter

STEP_SAMPLE_CNT:

sample count setting for dynamic threshold calculation. The actual value is STEP_SAMPLE_CNT<6:0>*8, default is 0xC, 96 sample count

Register 0x13 (STEP_CONF1)

Bit7	Bit6	Bit5	Bit4	Bit3	Bit2	Bit1	Bit0	R/W	Default
STEP_CLR	STEP_PRECISION<6:0>						RW	0x7F	

STEP_CLR: clear step count in register 0x07 ,0x08 and 0x0E

STEP_PRECISION<6:0>:

 threshold for acceleration change of two successive sample which is used to update sample_new register in step counter, the actual g value is STEP_PRECISION<6:0>*LSB*16 when STEP_PRECISION<6:0>!=0000000 & !=1111111
 When STEP_PRECISION<6:0>=0000000, always use P2P/8
 When STEP_PRECISION<6:0>=1111111, always use P2P/16
 When STEP_PRECISION<6:0>=?, always use P2P/4

Register 0x14 (STEP_CONF2)

Bit7	Bit6	Bit5	Bit4	Bit3	Bit2	Bit1	Bit0	R/W	Default
STEP_TIME_LOW<7:0>								RW	0x19

STEP_TIME_LOW<7:0>: the short time window for a valid step, the actual time is STEP_TIME_LOW<7:0>*(1/ODR)

Register 0x15 (STEP_CONF3)

Bit7	Bit6	Bit5	Bit4	Bit3	Bit2	Bit1	Bit0	R/W	Default
STEP_TIME_UP<7:0>								RW	0x00

STEP_TIME_UP<7:0>: time window for quitting step counter, the actual time is STEP_TIME_UP<7:0>*8*(1/ODR)

Register 0x16 (INT_EN0)

Bit7	Bit6	Bit5	Bit4	Bit3	Bit2	Bit1	Bit0	R/W	Default
1	SIG_STEP_I EN	1	1	STEP_IEN	HD_EN	RAISE_EN	1	RW	0xB1

 SIG_STEP_IEN: 1, enable significant step interrupt
 0, disable significant step interrupt

 STEP_IEN: 1, enable step valid interrupt
 0, disable step valid interrupt

 HD_EN: 1, enable hand-down interrupt
 0, disable hand-down interrupt

 RAISE_EN: 1, enable raise-hand interrupt
 0, disable raise-hand interrupt

Register 0x17 (INT_EN1)

Bit7	Bit6	Bit5	Bit4	Bit3	Bit2	Bit1	Bit0	R/W	Default
1	1	1	INT_DATA _EN					RW	0xE0

INT_DATA_EN: 1, enable data ready interrupt

0, disable data ready interrupt

Register 0x18 (INT_EN2)

Bit7	Bit6	Bit5	Bit4	Bit3	Bit2	Bit1	Bit0	R/W	Default
NO_MOT_EN_Z	NO_MOT_EN_Y	NO_MOT_EN_X	1	1	ANY_MOT_EN_Z	ANY_MOT_EN_Y	ANY_MOT_EN_X	RW	0x18

NO_MOT_EN_Z: 1, enable no_motion interrupt on Z axis
 0, disable no_motion interrupt on Z axis

NO_MOT_EN_Y: 1, enable no_motion interrupt on Y axis
 0, disable no_motion interrupt on Y axis

NO_MOT_EN_X: 1, enable no_motion interrupt on X axis
 0, disable no_motion interrupt on X axis

ANY_MOT_EN_Z: 1, enable any_motion interrupt on Z axis
 0, disable any_motion interrupt on Z axis

ANY_MOT_EN_Y: 1, enable any_motion interrupt on Y axis
 0, disable any_motion interrupt on Y axis

ANY_MOT_EN_X: 1, enable any_motion interrupt on X axis
 0, disable any_motion interrupt on X axis

Register 0x19 (INT_MAP0)

Bit7	Bit6	Bit5	Bit4	Bit3	Bit2	Bit1	Bit0	R/W	Default
1	INT1_SIG_STEP	1	1	INT1_STEP	INT1_HD	INT1_RAISE	INT1_SIG_MOT	RW	0xB0

INT1_SIG_STEP: 1, map significant step interrupt to INT1 pin
 0, not map significant step interrupt to INT1 pin

INT1_STEP: 1, map step valid interrupt to INT1 pin
 0, not map step valid interrupt to INT1 pin

INT1_HD: 1, map hand down interrupt to INT1 pin
 0, not map hand down interrupt to INT1 pin

INT1_RAISE: 1, map raise hand interrupt to INT1 pin
 0, not map raise hand interrupt to INT1 pin

INT1_SIG_MOT: 1, map significant interrupt to INT1 pin
 0, not map significant interrupt to INT1 pin

Register 0x1a (INT_MAP1)

Bit7	Bit6	Bit5	Bit4	Bit3	Bit2	Bit1	Bit0	R/W	Default
INT1_NO_MOT	1	1	INT1_DATA			1	INT1_ANY_MOT	RW	0x62

INT1_NO_MOT: 1, map no_motion interrupt to INT1 pin
 0, not map no_motion interrupt to INT1 pin

INT1_DATA: 1, map data ready interrupt to INT1 pin
 0, not map data ready interrupt to INT1 pin

INT1_ANY_MOT: 1, map any motion interrupt to INT1 pin
 0, not map any motion interrupt to INT1 pin

Register 0x1b (INT_MAP2)

Bit7	Bit6	Bit5	Bit4	Bit3	Bit2	Bit1	Bit0	R/W	Default
1	INT2_SIG_STEP	1	1	INT2_STEP	INT2_HD	INT2_RAISE	INT2_SIG_MOT	RW	0xB0

INT2_SIG_STEP: 1, map significant step interrupt to INT2 pin
 0, not map significant step interrupt to INT2 pin

INT2_STEP: 1, map step valid interrupt to INT2 pin
 0, not map step valid interrupt to INT2 pin

INT2_HD: 1, map hand down interrupt to INT2 pin
 0, not map hand down interrupt to INT2 pin

INT2_RAISE: 1, map raise hand interrupt to INT2 pin
 0, not map raise hand interrupt to INT2 pin

INT2_SIG_MOT: 1, map significant interrupt to INT2 pin
 0, not map significant interrupt to INT2 pin

Register 0x1c (INT_MAP3)

Bit7	Bit6	Bit5	Bit4	Bit3	Bit2	Bit1	Bit0	R/W	Default
INT2_NO_MOT	1	1	INT2_DATA			1	INT2_ANY_MOT	RW	0x62

INT2_NO_MOT: 1, map no_motion interrupt to INT2 pin
 0, not map no_motion interrupt to INT2 pin
 INT2_DATA: 1, map register data ready interrupt to INT2 pin
 0, not map register data ready interrupt to INT2 pin
 INT2_ANY_MOT: 1, map any motion interrupt to INT2 pin
 0, not map any motion interrupt to INT2 pin

Register 0x1d (SIG_STEP_TH)

Bit7	Bit6	Bit5	Bit4	Bit3	Bit2	Bit1	Bit0	R/W	Default
STEP_INTERVAL<7:0>								RW	0x00

STEP_INTERVAL <7:0>: threshold of significant step. When MOD(STEP_CNT, STEP_INTERVAL)=0, SIG_STEP_INT will be generated.

Register 0x1e (raise hand: X_TH Z_TH)

Bit7	Bit6	Bit5	Bit4	Bit3	Bit2	Bit1	Bit0	R/W	Default
Z_TH<3:0>				X_TH<3:0>				RW	0x66

X_TH<3:0>: 0~7.5, LSB 0.5 (unit : m/s²)
 Z_TH<3:0>: -8~7, LSB 1 (unit : m/s²)

Register 0x1f

Bit7	Bit6	Bit5	Bit4	Bit3	Bit2	Bit1	Bit0	R/W	Default
STEP_START_CNT<2:0>			STEP_COUNT_PEAK<1:0>		STEP_COUNT_P2P<2:0>			RW	0xA9

STEP_START_CNT<2:0>: th_step_pattern = 0/4/8/12/16/24/32/40
 STEP_COUNT_PEAK<2:0>: FIXED_PEAK = 0.05g + 0.05g * STEP_COUNT_PEAK<2:0>.
 This FIXED_PEAK is used in algorithm of STEP COUNTER.
 STEP_COUNT_PEAK<2> is in register 0x20<4> and
 STEP_COUNT_PEAK[2:0]= {0x20[4], 0x1F[4:3]}
 STEP_COUNT_P2P<2:0>: FIXED_P2P = 0.3g + 0.1g * STEP_COUNT_P2P<2:0>.
 STEP_COUNT_P2P[3:0]= {0x1F[2:0]}

Register 0x20 (INTPIN_CONF)

Bit7	Bit6	Bit5	Bit4	Bit3	Bit2	Bit1	Bit0	R/W	Default
DIS_PU_SENB	DIS_IE_AD0	EN_SPI3W	STEP_COUNT_PEAK<2>	INT2_OD	INT2_LVL	INT1_OD	INT1_LVL	RW	0x05

DIS_PU_SENB: 1, disable pull-up resistor of PIN_SENB
 0, enable pull-up resistor of PIN_SENB
 DIS_IE_AD0: 1, disable input of AD0
 0, not disable input of AD0
 EN_SPI3W: 1, enable 3W SPI
 0, 4W SPI
 STEP_COUNT_PEAK<2>: Definition in 0x1F<4:3>
 INT2_OD: 1, open-drain for INT2 pin
 0, push-pull for INT2 pin
 INT2_LVL: 1, logic high as active level for INT2 pin
 0, logic low as active level for INT2 pin
 INT1_OD: 1, open-drain for INT1 pin
 0, push-pull for INT1 pin
 INT1_LVL: 1, logic high as active level for INT1 pin
 0, logic low as active level for INT1 pin

Register 0x21 (INT_CFG)

Bit7	Bit6	Bit5	Bit4	Bit3	Bit2	Bit1	Bit0	R/W	Default
INT_RD_CLR	SHADOW_DIS	DIS_I2C	1	1	1	LATCH_INT_STEP	LATCH_INT	RW	0x1C

INT_RD_CLR: 1, clear all the interrupts in latched-mode, when any read operation to any of registers from 0x09 to 0x0D
 0, clear the related interrupts, only when read the register INT_ST (0x09 to 0x0D),
 no matter the interrupts in latched-mode, or in non-latched-mode.
 Reading 0x09 will clear the register 0x09 only and the others keep the status

SHADOW_DIS: 1, disable the shadowing function for the acceleration data
 0, enable the shadowing function for the acceleration data.
 when shadowing is enabled, the MSB of the acceleration data is locked,
 when corresponding LSB of the data is reading.
 This can ensure the integrity of the acceleration data during the reading.
 The MSB will be unlocked when the MSB is read.

DIS_I2C: 1: disable I2C. Setting this bit to 1 in SPI mode is recommended
 0: enable I2C

LATCH_INT_STEP: 1, step related interrupt is in latch mode
 0, step related interrupt is in non-latch mode

LATCH_INT: 1, interrupt is in latch mode
 0, interrupt is in non-latch mode

Register 0x27 (OS_CUST_X)

Bit7	Bit6	Bit5	Bit4	Bit3	Bit2	Bit1	Bit0	R/W	Default
OS_CUST_X<7:0>								RW	0x00

OS_CUST_X<7:0>: offset calibration of X axis for user, the LSB depends on full-scale of the device which is 3.9mg in 2g range, 7.8mg in 4g range, 15.6mg in 8g range, 31.2mg in 16g, and 62.5mg in 32g

Register 0x28 (OS_CUST_Y)

Bit7	Bit6	Bit5	Bit4	Bit3	Bit2	Bit1	Bit0	R/W	Default
OS_CUST_Y<7:0>								RW	0x00

OS_CUST_Y<7:0>: offset calibration of Y axis for user, the LSB depends on full-scale of the device which is 3.9mg in 2g range, 7.8mg in 4g range, 15.6mg in 8g range, 31.2mg in 16g, and 62.5mg in 32g

Register 0x29 (OS_CUST_Z)

Bit7	Bit6	Bit5	Bit4	Bit3	Bit2	Bit1	Bit0	R/W	Default
OS_CUST_Z<7:0>								RW	0x00

OS_CUST_Z<7:0>: offset calibration of Z axis for user, the LSB depends on full-scale of the device which is 3.9mg in 2g range, 7.8mg in 4g range, 15.6mg in 8g range, 31.2mg in 16g, and 62.5mg in 32g

Register 0x2a (RAISE_WAKE_SUM_TH RAISE_WAKE_DIFF_TH)

Bit7	Bit6	Bit5	Bit4	Bit3	Bit2	Bit1	Bit0	R/W	Default	
RAISE_WAKE_DIFF_TH<1:0>		RAISE_WAKE_SUM_TH<5:0>							RW	0xD8

RAISE_WAKE_SUM_TH <5:0>: 0 ~ 31.5 (LSB 0.5 m/s²)

RAISE_WAKE_DIFF_TH<3:0>	UNIT (m/s ²)
0	0.2
1	0.3
2	0.4
3	0.5
4	0.6
5	0.7
6	0.8
7	0.9
8	1.0
9	1.1
10	1.2
default	0.2

Register 0x2b (RAISE_WAKE_DIFF_TH HD_X_TH HD_Z_TH)

Bit7	Bit6	Bit5	Bit4	Bit3	Bit2	Bit1	Bit0	R/W	Default
HD_Z_TH<2:0>			HD_X_TH<2:0>			RAISE_WAKE_DIFF_TH<3:2>		RW	0x7C

HD_X_TH<2:0> : hand down x threshold, 0~7 (m/s²)

HD_Z_TH<2:0> : hand down z threshold, 0~7 (m/s²)

Register 0x2c (MOT_CONF0)

Bit7	Bit6	Bit5	Bit4	Bit3	Bit2	Bit1	Bit0	R/W	Default
NO_MOT_DUR<5:0>						ANY_MOT_DUR<1:0>		RW	0x00

NO_MOT_DUR<5:0>: no motion interrupt will be triggered when slope < NO_MOT_TH for the times which defined by NO_MOT_DUR<5:0>



Duration = (NO_MOT_DUR<3:0> + 1) * 1s, if NO_MOT_DUR<5:4> =b00
 Duration = (NO_MOT_DUR<3:0> + 4) * 5s, if NO_MOT_DUR<5:4> =b01
 Duration = (NO_MOT_DUR<3:0> + 10) * 10s, if NO_MOT_DUR<5:4> =b1x

ANY_MOT_DUR<1:0>: any motion interrupt will be triggered when slope > ANY_MOT_TH for (ANY_MOT_DUR<1:0> + 1) samples

Register 0x2d (MOT_CONF1)

Bit7	Bit6	Bit5	Bit4	Bit3	Bit2	Bit1	Bit0	R/W	Default
NO_MOT_TH<7:0>								RW	0x00

NO_MOT_TH<7:0>: Threshold of no-motion interrupt. The threshold definition is as following
 TH= NO_MOT_TH<7:0> * 16 * LSB

Register 0x2e (MOT_CONF2)

Bit7	Bit6	Bit5	Bit4	Bit3	Bit2	Bit1	Bit0	R/W	Default
ANY_MOT_TH<7:0>								RW	0x00

ANY_MOT_TH<7:0>: Threshold of any motion interrupt. The threshold definition is as following
 TH= ANY_MOT_TH<7:0> * 16 * LSB

Register 0x2f (MOT_CONF3)

Bit7	Bit6	Bit5	Bit4	Bit3	Bit2	Bit1	Bit0	R/W	Default
		SIG_MOT_TPROOF<1:0>		SIG_MOT_TSKIP<1:0>		SIG_MOT_SEL		RW	0x00

SIG_MOT_TPROOF<1:0>: 00, T_PROOF=0.25s
 01, T_PROOF=0.5s
 10, T_PROOF=1s
 11, T_PROOF=2s

SIG_MOT_TSKIP<1:0>: 00, T_SKIP=1.5s
 01, T_SKIP=3s
 10, T_SKIP=6s
 11, T_SKIP=12s

SIG_MOT_SEL: 1, select significant motion interrupt
 0, select any motion interrupt

Register 0x30

Bit7	Bit6	Bit5	Bit4	Bit3	Bit2	Bit1	Bit0	R/W	Default
MO_BP_CO	STEP_BP_CO				NO_MOT_RST_N	SIG_MOT_RST_N	ANY_MOT_RST_N	RW	0x1F

MO_BP_CO: 1, motion detector will use data without OS_CUST
 0, motion detector will use data with OS_CUST

STEP_BP_CO: 1, pedometer will use data without OS_CUST
 0, pedometer will use data with OS_CUST

NO_MOT_RST_N: 0, Reset no motion detector. After reset, user should write 1 back.

SIG_MOT_RST_N: 0, Reset significant motion detector. After reset, user should write 1 back.

ANY_MOT_RST_N: 0, Reset any motion detector. After reset, user should write 1 back.

Register 0x32 (ST)

Bit7	Bit6	Bit5	Bit4	Bit3	Bit2	Bit1	Bit0	R/W	Default
SELFTTEST_BIT					SELFTTEST_SIGN	BP_AXIS_STEP<1:0>		RW	0x00

SELFTTEST_BIT: 1, self-test enabled. When self-test enabled, a delay of 3ms is necessary for the value settling.
 0, normal

SELFTTEST_SIGN: 1, set self-test excitation positive
 0, set self-test excitation negative

BP_AXIS_STEP<1:0>: 11, bypass Z axis, use only X and Y axes data for step counter algorithm
 10, bypass Y axis, use only X and Z axes data for step counter algorithm
 01, bypass X axis, use only Y and Z axes data for step counter algorithm
 00, use all of 3 axes data for step counter algorithm

Register 0x34 (Y_TH YZ_TH_SEL)

Bit7	Bit6	Bit5	Bit4	Bit3	Bit2	Bit1	Bit0	R/W	Default	
YZ_TH_SEL<2:0>			Y_TH<4:0>						RW	0x9D

Y_TH: -16 ~ 15 (m/s²)

YZ_TH_SEL<2:0>	UNIT (m/s ²)
0	7.0
1	7.5
2	8.0
3	8.5
4	9.0
5	9.5
6	10.0
7	10.5

Register 0x35 (RAISE_WAKE_PERIOD)

Bit7	Bit6	Bit5	Bit4	Bit3	Bit2	Bit1	Bit0	R/W	Default
RAISE_WAKE_PERIOD<7:0>								RW	0x81

RAISE_WAKE_PERIOD<10:0>: * ODR period = wake count (EX. ODR = 1ms, 0X35 = 100 → wake count = 0.1 sec)

Register 0x36 (SR)

Bit7	Bit6	Bit5	Bit4	Bit3	Bit2	Bit1	Bit0	R/W	Default
SOFT_RESET								RW	0x00

SOFT_RESET: 0xB6, soft reset all of the registers. After soft-reset, user should write 0x00 back

Register 0x3e (RAISE_WAKE_TIMEOUT_TH)

Bit7	Bit6	Bit5	Bit4	Bit3	Bit2	Bit1	Bit0	R/W	Default
RAISE_WAKE_TIMEOUT_TH<7:0>								RW	0x00

Register 0x3f (RAISE_WAKE_TIMEOUT_TH RAISE_WAKE_PERIOD RAISE_WAKE_EN)

Bit7	Bit6	Bit5	Bit4	Bit3	Bit2	Bit1	Bit0	R/W	Default
RAISE_WAKE_PERIOD<10:8>				RAISE_WAKE_TIMEOUT_TH<11:8>				RW	0x02

RAISE_WAKE_TIMEOUT_TH<11:0> * ODR period = timeout count (EX. ODR = 1ms, 0X3e = 100 → timeout count = 0.1 sec)

ORDERING INFORMATION

Ordering Number	Temperature Range	Package	Packaging
QMA7981-TR	-40°C~85°C	LGA-12	Tape and Reel: 5k pieces/reel

Caution

This part is sensitive to damage by electrostatic discharge. Use ESD precautionary procedures when touching, removing or inserting.

CAUTION: ESDS CAT. 1B

FIND OUT MORE

For more information on QST's Accelerometer Sensors contact us at 86-21-50497300.

The application circuits herein constitute typical usage and interface of QST product. QST does not provide warranty or assume liability of customer-designed circuits derived from this description or depiction.

 矽睿	Document #: 13-52-12	Title: QMA7981 Datasheet	Rev: D
---	-----------------------------	---------------------------------	----------------------

QST reserves the right to make changes to improve reliability, function or design. QST does not assume any liability arising out of the application or use of any product or circuit described herein; neither does it convey any license under its patent rights nor the rights of others.

ISO9001 : 2015

China Patents 201510000399.8, 201510000425.7, 201310426346.3, 201310426677.7, 201310426729.0, 201210585811.3 and 201210553014.7 apply to the technology described.