

2K x 8 Reprogrammable PROM

Features

- 5V \pm 10% VCC, commercial, industrial and military
- Windowed Packages available for reprogrammability
- OTP (One-Time-Programmable) Packages available
- High speed
 - 20 ns (commercial)
 - 25 ns (military)
- CMOS for optimum speed/power
- Slim 300-mil or standard 600-mil packaging available
- Direct replacement for Cypress PROMs
- Direct replacement for bipolar PROMs
- EPROM technology 100% programmable
- Low power
 - 660 mW (commercial and military)
- Low standby power
 - 220 mW (commercial and military)
- TTL-compatible I/O

General Description

The QP7C291A, and QP7C292A are high-performance 2K-word by 8-bit CMOS PROMs. They are functionally identical, but are packaged in 300-mil (QP7C291A) and 600-mil wide plastic and hermetic DIP packages (QP7C292A). The QP7C291A is also available in LCC/PLCC packages.

The devices are available in windowed packages (Erasable when exposed to UV light) and can be reprogrammed. They are also available in non-windowed OTP (One-Time-Programmable) hermetic and plastic packages.

The memory cells utilize proven EPROM floating-gate technology and byte-wide intelligent programming algorithms.

The QP7C291A, and QP7C292A, are plug-in replacements for Cypress PROMs. They are also designed to be plug-in replacements for bipolar devices and offer the advantages of lower power, re-programmability, superior performance and programming yield. The EPROM cell requires only 12.5V for the supervoltage and low current requirements allow for gang programming. The EPROM cells allow for each memory location to be tested 100%, as each location is written into, erased, and exercised prior to packaging. Each PROM is tested for AC performance to guarantee that after customer programming the product will meet DC and AC specification limits.

A read is accomplished by placing an active LOW signal on CS1, and active HIGH signals on CS2 and CS3. The contents of the memory location addressed by the address line (A0 – A10) will become available on the output lines (O0 – O7).

QP Semiconductor products are not authorized for use in any space applications. The inclusion of QP Semiconductor products in space applications implies that the space application manufacturer assumes all risk of such use and in doing so indemnifies QP Semiconductor against all charges.

Connection Diagrams

	CerDIP/PDIP/Cerpack 24 Lead	LCC/PLCC
<p>QP7C291A QP7C292A</p> <p>Hermetic Packages available in both Erasable (Windowed and OTP – One-Time-Programmable (Non-Windowed) versions.</p> <p>Molded Plastic Packages (PDIP/PLCC are only available as OTP (Non-Windowed).</p>		

Block Diagram

QP7C291A
QP7C292A

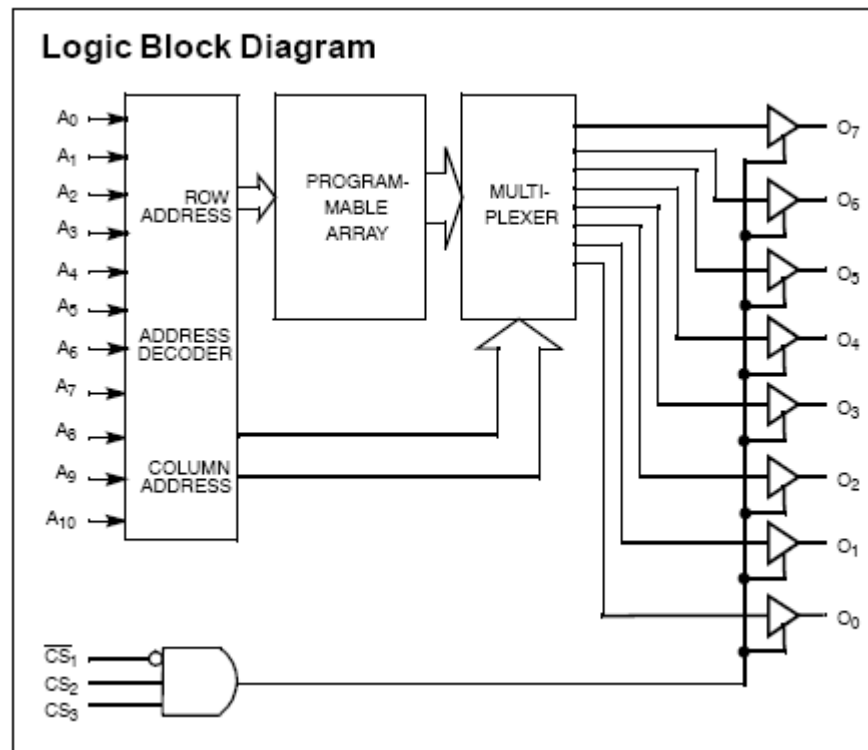

Absolute Maximum Ratings

Stresses above the AMR may cause permanent damage, extended operation at AMR may degrade performance and affect reliability

Condition	Units	Notes
Supply Voltage to Ground	-0.5 to 7.0 Volts	
DC Voltage Applied to Outputs in High Z State	-0.5 to 7.0 Volts	
DC Input Voltage	-3.0V to 7.0 Volts	
DC Program Voltage	13.0 Volts	
UV Exposure	7258 W _{SEC} /cm ²	

Storage Temperature	-65 to +155 °C	
Ambient Temperature with Power Applied	-55 to +125 °C	
Junction Temperature	150 °C	/1 /2

Recommended Operating Conditions

Condition		Units	Notes
Supply Voltage Range	4.5 to 5.5	Volts DC	5V ± 10%
Case Operating Range (T _c)	-0C to +70	°C	Commercial
Case Operating Range (T _c)	-40C to +85	°C	Industrial
Case Operating Range (T _c)	-55 to +125	°C	Military

Notes:

Apply to Absolute Maximum, Recommended Operating Conditions and Electrical Performance Characteristics.

/1 – Applies to all versions, but is critical for molded plastic products. T_j above listed limits can activate mold compound flame retardant.

/2 – Maximum T_j is not to be exceeded.

/3 – V_{CC} 4.5 to 5.5 Volts

/4 – For Test Purposes, not more than one output at a time should be shorted. Short circuit test duration should not exceed 30 seconds.

TABLE I – ELECTRICAL PERFORMANCE CHARACTERISTICS

Test	Symbol	Conditions /3 Case Operating Range (°C)	Min	Max	Unit
Output Voltage High	V _{OH}	V _{CC} = 4.5V, I _{OH} = -4.0mA	2.4		V
Output Voltage Low	V _{OL}	V _{CC} = 4.5V, I _{OL} = 16.0mA		0.4	V
Input High Voltage	V _{IH}	Guaranteed Input logical High for all inputs	2.0	V _{CC}	V
Input Low Voltage	V _{IL}	Guaranteed Input logical Low for all inputs		0.8	V
Input Load Current	I _{IX}	GND ≤ V _{IN} ≤ V _{CC}	-10	10	µA
Output Leakage Current	I _{OZ}	GND ≤ V _{OUT} ≤ V _{CC} , Output Disabled	-10	10	µA
Output Short Circuit Current /4	I _{OS}	V _{CC} = 5.5V, V _{OUT} = GND	-20	-90	mA
Operating Supply Current	I _{CC}	V _{CC} = 5.5V, I _{OUT} = 0 mA			
		20ns Commercial		120	mA
		25ns Commercial		90	mA
		35ns Commercial		90	mA
		50ns Commercial		90	mA
		25ns Military		120	mA
		35ns Military		90	mA
50ns Military		90	mA		
Programming Supply Voltage	V _{PP}		12	13	V

TABLE I – ELECTRICAL PERFORMANCE CHARACTERISTICS

Test	Symbol	Conditions /3 Case Operating Range (°C)	Min	Max	Unit
Programming Supply Current	I _{PP}			50	MA
Input High Programming Voltage	V _{IHP}		3.0		V
Input Low Programming Voltage	V _{ILP}			0.4	V
Input Capacitance	C _{IN}	T _A =25°C, f=1MHz, V _{CC} =5.0V		10	pF
Output Capacitance	C _{OUT}	T _A =25°C, f=1MHz, V _{CC} =5.0V		10	pF
Address to Output Valid	t _{AA}	QP7C291(292)A-20		20	nS
		QP7C291(292)A-25		25	nS
		QP7C291(292)A-35		35	nS
		QP7C291(292)A-50		50	nS
Chip Select Inactive to High Z	T _{HZCS1}	QP7C291(292)A-20		15	nS
		QP7C291(292)A-25		15	nS
		QP7C291(292)A-35		20	nS
		QP7C291(292)A-50		20	nS
Chip Select Active to Output	T _{ACS1}	QP7C291(292)A-20		15	nS
		QP7C291(292)A-25		15	nS
		QP7C291(292)A-35		20	nS
		QP7C291(292)A-50		20	nS

AC Test Loads

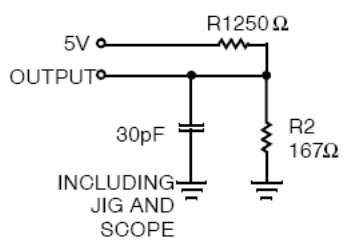

(a) Normal Load

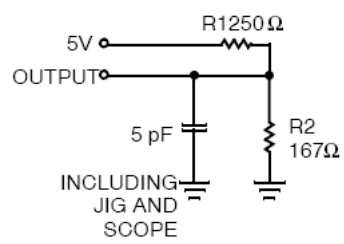

(b) High Z Load

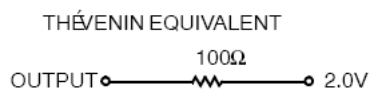
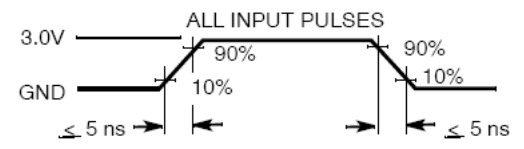

Waveforms

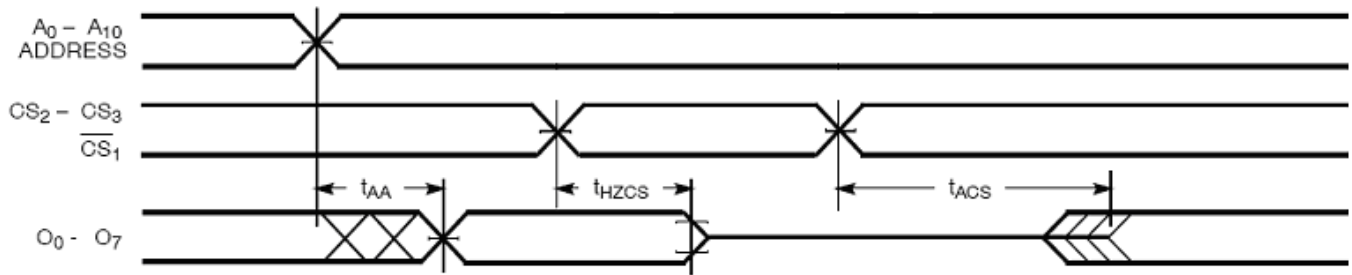

Mode	Pin Function				
	A ₁₀ -A ₀ /5	CS ₃ /PGM	CS ₂ /VFY	CS ₁ BAR/V _{PP}	O ₇ -O ₀
Read	Address	V _{IH}	V _{IH}	V _{IL}	Output Data
Output Disable	Address	X /6	X /6	V _{IH}	High Z
Output Disable	Address	X /6	V _{IL}	X /6	High Z
Output Disable	Address	V _{IL}	X /6	X /6	High Z
Program	Address	V _{ILP}	V _{IHP}	V _{PP}	Data In
Program Verify	Address	V _{IHP}	V _{ILP}	V _{PP}	Output Data
Program Inhibit	Address	V _{IHP}	V _{IHP}	V _{PP}	High Z
Intelligent Program	Address	V _{ILP}	V _{IHP}	V _{PP}	Data In
Blank Check Zeros	Address	V _{IHP}	V _{ILP}	V _{PP}	Zeros Out

/5 – Normal V_{IH}/V_{IL} Levels representing Address Desired
 /6 – X = "Don't Care", but not to exceed V_{CC} +5%

Erase Characteristics:

Wavelengths of light less than 4000 Angstroms begin to erase these PROMs. For this reason, an opaque label should be placed over the window if the PROM is exposed to sunlight or fluorescent lighting for extended periods of time.

The recommended dose of ultraviolet light for erasure is a wavelength of 2537 Angstroms for a minimum dose (UV intensity x exposure time of 25 Wsec/cm². For an ultraviolet lamp with a 12 mW/cm² power rating, the exposure time would be approximately 35 minutes. These PROMs need to be within 1 inch of the lamp during erasure. Permanent damage may result if the PROM is exposed to high-intensity UV light for an extended period of time.

7258 Wsec/cm² is the recommended maximum dosage.

Programming Information:

The QP7C291A and QP7C292A program using the same programming algorithm as Cypress 7C291A and 7C292A devices. A variety of programming equipment currently supports the Cypress Algorithm. QP Semiconductor has verified that the devices program on Data I/O Unisite and on a programmer supplied by EETools.

Ordering Information

Temp Range	t _{AA} ns	Part Number	Package	Mil-Std-1835	Generic
Commercial	20	QP7C291A-20JC	28-Lead PLCC		7C291A
Commercial	20	QP7C291A-20PC	24-Lead 300-mil Plastic DIP		7C291A
Commercial	20	QP7C291A-20WC	24-Lead 300-mil Windowed CerDIP	GDIP3-T24	7C291A
Commercial	20	QP7C292A-20PC	24-Lead 600-mil Plastic DIP		7C292A
Commercial	20	QP7C292A-20WC	24-Lead 600-mil Windowed CerDIP	GDIP1-T24	7C292A
Commercial	25	QP7C291A-25JC	28-Lead PLCC		7C291A
Commercial	25	QP7C291A-25PC	24-Lead 300-mil Plastic DIP		7C291A
Commercial	25	QP7C291A-25WC	24-Lead 300-mil Windowed CerDIP	GDIP3-T24	7C291A
Commercial	25	QP7C291AL-25JC	28-Lead PLCC		7C291A
Commercial	25	QP7C291AL-25PC	24-Lead 300-mil Plastic DIP		7C291A
Commercial	25	QP7C291AL-25WC	24-Lead 300-mil Windowed CerDIP	GDIP3-T24	7C291A
Commercial	25	QP7C292A-25PC	24-Lead 600-mil Plastic DIP		7C292A
Commercial	25	QP7C292A-25WC	24-Lead 600-mil Windowed CerDIP	GDIP1-T24	7C292A
Commercial	25	QP7C292AL-25PC	24-Lead 600-mil Plastic DIP		7C292A
Commercial	25	QP7C292AL-25WC	24-Lead 600-mil Windowed CerDIP	GDIP1-T24	7C292A
Commercial	35	QP7C291A-35JC	28-Lead PLCC		7C291A
Commercial	35	QP7C291A-35PC	24-Lead 300-mil Plastic DIP		7C291A
Commercial	35	QP7C291A-35WC	24-Lead 300-mil Windowed CerDIP	GDIP3-T24	7C291A
Commercial	35	QP7C291AL-35JC	28-Lead PLCC		7C291A
Commercial	35	QP7C291AL-35PC	24-Lead 300-mil Plastic DIP		7C291A
Commercial	35	QP7C291AL-35WC	24-Lead 300-mil Windowed CerDIP	GDIP3-T24	7C291A
Commercial	35	QP7C292A-35PC	24-Lead 600-mil Plastic DIP		7C292A
Commercial	35	QP7C292A-35WC	24-Lead 600-mil Windowed CerDIP	GDIP1-T24	7C292A
Commercial	35	QP7C292AL-35PC	24-Lead 600-mil Plastic DIP		7C292A
Commercial	35	QP7C292AL-35WC	24-Lead 600-mil Windowed CerDIP	GDIP1-T24	7C292A
Industrial	20	QP7C291A-20JI	28-Lead PLCC		7C291A
Industrial	20	QP7C291A-20PI	24-Lead 300-mil Plastic DIP		7C291A
Industrial	20	QP7C291A-20WI	24-Lead 300-mil Windowed CerDIP	GDIP3-T24	7C291A
Industrial	20	QP7C292A-20PI	24-Lead 600-mil Plastic DIP		7C292A
Industrial	20	QP7C292A-20WI	24-Lead 600-mil Windowed CerDIP	GDIP1-T24	7C292A
Industrial	25	QP7C291A-25DI	24-Lead 300-mil CerDIP	GDIP3-T24	7C291A
Industrial	25	QP7C291A-25JI	28-Lead PLCC		7C291A
Industrial	25	QP7C291A-25KI	24-Lead Flatpack	GDFP2-F24	7C291A
Industrial	25	QP7C291A-25LI	28-Lead LCC	CQCC1-N28	7C291A
Industrial	25	QP7C291A-25PI	24-Lead 300-mil Plastic DIP		7C291A
Industrial	25	QP7C291A-25QI	28-Lead Windowed LCC	CQCC1-N28	7C291A
Industrial	25	QP7C291A-25TI	24-Lead Windowed Flatpack	GDFP2-F24	7C291A
Industrial	25	QP7C291A-25WI	24-Lead 300-mil Windowed CerDIP	GDIP3-T24	7C291A
Industrial	25	QP7C291AL-25JI	28-Lead PLCC		7C291A
Industrial	25	QP7C291AL-25PI	24-Lead 300-mil Plastic DIP		7C291A
Industrial	25	QP7C291AL-25WI	24-Lead 300-mil Windowed CerDIP	GDIP3-T24	7C291A
Industrial	25	QP7C292A-25DI	24-Lead 600-mil CerDIP	GDIP1-T24	7C292A
Industrial	25	QP7C292A-25PI	24-Lead 600-mil Plastic DIP		7C292A
Industrial	25	QP7C292A-25WI	24-Lead 600-mil Windowed CerDIP	GDIP1-T24	7C292A
Industrial	25	QP7C292AL-25PI	24-Lead 600-mil Plastic DIP		7C292A
Industrial	25	QP7C292AL-25WI	24-Lead 600-mil Windowed CerDIP	GDIP1-T24	7C292A
Industrial	35	QP7C291A-35DI	24-Lead 300-mil CerDIP	GDIP3-T24	7C291A
Industrial	35	QP7C291A-35JI	28-Lead PLCC		7C291A
Industrial	35	QP7C291A-35KI	24-Lead Flatpack	GDFP2-F24	7C291A
Industrial	35	QP7C291A-35LI	28-Lead LCC	CQCC1-N28	7C291A

QP7C291A / QP7C292A

Temp Range	t _{AA} ns	Part Number	Package	Mil-Std-1835	Generic
Industrial	35	QP7C291A-35PI	24-Lead 300-mil Plastic DIP		7C291A
Industrial	35	QP7C291A-35QI	28-Lead Windowed LCC	CQCC1-N28	7C291A
Industrial	35	QP7C291A-35TI	24-Lead Windowed Flatpack	GDIP2-F24	7C291A
Industrial	35	QP7C291A-35WI	24-Lead 300-mil Windowed CerDIP	GDIP3-T24	7C291A
Industrial	35	QP7C291AL-35JI	28-Lead PLCC		7C291A
Industrial	35	QP7C291AL-35PI	24-Lead 300-mil Plastic DIP		7C291A
Industrial	35	QP7C291AL-35WI	24-Lead 300-mil Windowed CerDIP	GDIP3-T24	7C291A
Industrial	35	QP7C292A-35DI	24-Lead 600-mil CerDIP	GDIP1-T24	7C292A
Industrial	35	QP7C292A-35PI	24-Lead 600-mil Plastic DIP		7C292A
Industrial	35	QP7C292A-35WI	24-Lead 600-mil Windowed CerDIP	GDIP1-T24	7C292A
Industrial	35	QP7C292AL-35PI	24-Lead 600-mil Plastic DIP		7C292A
Industrial	35	QP7C292AL-35WI	24-Lead 600-mil Windowed CerDIP	GDIP1-T24	7C292A
Industrial	50	QP7C291A-50DI	24-Lead 300-mil CerDIP	GDIP3-T24	7C291A
Industrial	50	QP7C291A-50KI	24-Lead Flatpack	GDIP2-F24	7C291A
Industrial	50	QP7C291A-50LI	28-Lead LCC	CQCC1-N28	7C291A
Industrial	50	QP7C291A-50QI	28-Lead Windowed LCC	CQCC1-N28	7C291A
Industrial	50	QP7C291A-50TI	24-Lead Windowed Flatpack	GDIP2-F24	7C291A
Industrial	50	QP7C291A-50WI	24-Lead 300-mil Windowed CerDIP	GDIP3-T24	7C291A
Industrial	50	QP7C292A-50DI	24-Lead 600-mil CerDIP	GDIP1-T24	7C292A
Industrial	50	QP7C292A-50WI	24-Lead 600-mil Windowed CerDIP	GDIP1-T24	7C292A
Military	25	QP7C291A-25DMB	24-Lead 300-mil CerDIP	GDIP3-T24	7C291A
Military	25	QP7C291A-25KMB	24-Lead Flatpack	GDIP2-F24	7C291A
Military	25	QP7C291A-25LMB	28-Lead LCC	CQCC1-N28	7C291A
Military	25	QP7C291A-25QMB	28-Lead Windowed LCC	CQCC1-N28	7C291A
Military	25	QP7C291A-25TMB	24-Lead Windowed Flatpack	GDIP2-F24	7C291A
Military	25	QP7C291A-25WMB	24-Lead 300-mil Windowed CerDIP	GDIP3-T24	7C291A
Military	25	QP7C292A-25DMB	24-Lead 600-mil CerDIP	GDIP1-T24	7C292A
Military	25	QP7C292A-25WMB	24-Lead 600-mil Windowed CerDIP	GDIP1-T24	7C292A
Military	25	5962-87650053A	28-Lead Windowed LCC	CQCC1-N28	7C291A
Military	25	5962-8765005JA	24-Lead 600-mil Windowed CerDIP	GDIP1-T24	7C292A
Military	25	5962-8765005KA	24-Lead Windowed Flatpack	GDIP2-F24	7C291A
Military	25	5962-8765005LA	24-Lead 300-mil Windowed CerDIP	GDIP3-T24	7C291A
Military	35	5962-88734043A	28-Lead LCC	CQCC1-N28	7C291A
Military	35	5962-8873404JA	24-Lead 600-mil CerDIP	GDIP1-T24	7C292A
Military	35	5962-8873404KA	24-Lead Flatpack	GDIP2-F24	7C291A
Military	35	5962-8873404LA	24-Lead 300-mil CerDIP	GDIP3-T24	7C291A
Military	35	QP7C291A-35DMB	24-Lead 300-mil CerDIP	GDIP3-T24	7C291A
Military	35	QP7C291A-35KMB	24-Lead Flatpack	GDIP2-F24	7C291A
Military	35	QP7C291A-35LMB	28-Lead LCC	CQCC1-N28	7C291A
Military	35	QP7C291A-35QMB	28-Lead Windowed LCC	CQCC1-N28	7C291A
Military	35	QP7C291A-35TMB	24-Lead Windowed Flatpack	GDIP2-F24	7C291A
Military	35	QP7C291A-35WMB	24-Lead 300-mil Windowed CerDIP	GDIP3-T24	7C291A
Military	35	QP7C292A-35DMB	24-Lead 600-mil CerDIP	GDIP1-T24	7C292A
Military	35	QP7C292A-35WMB	24-Lead 600-mil Windowed CerDIP	GDIP1-T24	7C292A
Military	35	5962-87650033A	28-Lead Windowed LCC	CQCC1-N28	7C291A
Military	35	5962-8765003JA	24-Lead 600-mil Windowed CerDIP	GDIP1-T24	7C292A
Military	35	5962-8765003KA	24-Lead Windowed Flatpack	GDIP2-F24	7C291A
Military	35	5962-8765003LA	24-Lead 300-mil Windowed CerDIP	GDIP3-T24	7C291A
Military	35	5962-88734033A	28-Lead LCC	CQCC1-N28	7C291A
Military	35	5962-8873403JA	24-Lead 600-mil CerDIP	GDIP1-T24	7C292A
Military	35	5962-8873403KA	24-Lead Flatpack	GDIP2-F24	7C291A
Military	35	5962-8873403LA	24-Lead 300-mil CerDIP	GDIP3-T24	7C291A

Temp Range	t _{AA} ns	Part Number	Package	Mil-Std-1835	Generic
Military	45	5962-87650043A	28-Lead Windowed LCC	CQCC1-N28	7C291A
Military	45	5962-8765004JA	24-Lead 600-mil Windowed CerDIP	GDIP1-T24	7C292A
Military	45	5962-8765004KA	24-Lead Windowed Flatpack	GDIP2-F24	7C291A
Military	45	5962-8765004LA	24-Lead 300-mil Windowed CerDIP	GDIP3-T24	7C291A
Military	45	5962-88734023A	28-Lead LCC	CQCC1-N28	7C291A
Military	45	5962-8873402JA	24-Lead 600-mil CerDIP	GDIP1-T24	7C292A
Military	45	5962-8873402KA	24-Lead Flatpack	GDIP2-F24	7C291A
Military	45	5962-8873402LA	24-Lead 300-mil CerDIP	GDIP3-T24	7C291A
Military	50	QP7C291A-50DMB	24-Lead 300-mil CerDIP	GDIP3-T24	7C291A
Military	50	QP7C291A-50KMB	24-Lead Flatpack	GDIP2-F24	7C291A
Military	50	QP7C291A-50LMB	28-Lead LCC	CQCC1-N28	7C291A
Military	50	QP7C291A-50QMB	28-Lead Windowed LCC	CQCC1-N28	7C291A
Military	50	QP7C291A-50TMB	24-Lead Windowed Flatpack	GDIP2-F24	7C291A
Military	50	QP7C291A-50WMB	24-Lead 300-mil Windowed CerDIP	GDIP3-T24	7C291A
Military	50	QP7C292A-50DMB	24-Lead 600-mil CerDIP	GDIP1-T24	7C292A
Military	50	QP7C292A-50WMB	24-Lead 600-mil Windowed CerDIP	GDIP1-T24	7C292A
Military	50	5962-87650013A	28-Lead Windowed LCC	CQCC1-N28	7C291A
Military	50	5962-8765001JA	24-Lead 600-mil Windowed CerDIP	GDIP1-T24	7C292A
Military	50	5962-8765001KA	24-Lead Windowed Flatpack	GDIP2-F24	7C291A
Military	50	5962-8765001LA	24-Lead 300-mil Windowed CerDIP	GDIP3-T24	7C291A
Military	55	5962-87650023A	28-Lead Windowed LCC	CQCC1-N28	7C291A
Military	55	5962-8765002JA	24-Lead 600-mil Windowed CerDIP	GDIP1-T24	7C292A
Military	55	5962-8765002KA	24-Lead Windowed Flatpack	GDIP2-F24	7C291A
Military	55	5962-8765002LA	24-Lead 300-mil Windowed CerDIP	GDIP3-T24	7C291A
Military	55	5962-88734013A	28-Lead LCC	CQCC1-N28	7C291A
Military	55	5962-8873401JA	24-Lead 600-mil CerDIP	GDIP1-T24	7C292A
Military	55	5962-8873401KA	24-Lead Flatpack	GDIP2-F24	7C291A
Military	55	5962-8873401LA	24-Lead 300-mil CerDIP	GDIP3-T24	7C291A

* denotes Lead Free Lead Finish

In addition to those products listed above, QP Semiconductor supports Industrial Temperature Range, Source Control Drawing SCD, and custom package development for this product family.

Notes:

Hermetic Package outline information and specifications are defined by Mil-Std-1835 package dimension requirements.

Military Products manufactured by QP Semiconductor are compliant to the assembly, burn-in, test and quality conformance requirements of Test Methods 5004 & 5005 of Mil-Std-883 for Class B or Q devices as appropriate. The appropriate DSCC Detail Specifications define the electrical test requirements for each device.

The listed drawings, Mil-PRF-38535, Mil-Std-883 and Mil-Std-1835 are available online at <http://www.dsccl.dla.mil/>

Additional information is available at our website <http://www.qpsemi.com>