

Product Overview

The QPA9119 is a high linearity driver amplifier in a low-cost, RoHS compliant, surface mount package. This InGaP/GaAs HBT delivers high performance across a broad range of frequencies with +44 dBm OIP3 and +27.2 dBm P1dB while only consuming 130 mA quiescent current. All devices are 100% RF and DC tested.

The QPA9119 incorporates on-chip features that differentiate it from other products in the market. The amplifier integrates an on-chip DC over-voltage and RF over-drive protection. This protects the amplifier from electrical DC voltage surges and high input RF input power levels that may occur in a system. On-chip ESD protection allows the amplifier to have a very robust Class 1C HBM ESD rating.

The QPA9119 is targeted for use as a driver amplifier in wireless infrastructure where high linearity, medium power, and high efficiency are required. The device an excellent candidate for transceiver line cards in current and next generation multi-carrier 3G / 4G base stations.

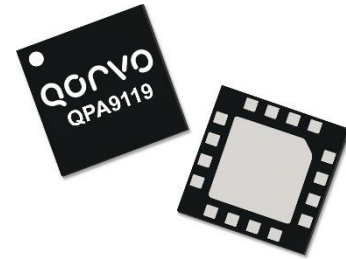

16 Pad 3 x 3 mm QFN Package

Key Features

- 400 – 4200 MHz
- +27.2 dBm P1dB
- +44 dBm Output IP3
- 17 dB Gain at 2140 MHz
- +5 V Single Supply, I_{CC} = 130 mA
- Internal RF Overdrive Protection
- Internal DC Overvoltage Protection
- On Chip ESD Protection
- 3 x 3 mm QFN Package

Applications

- Repeaters / DAS
- Mobile Infrastructure
- Defense Communications
- General Purpose Wireless

Functional Block Diagram

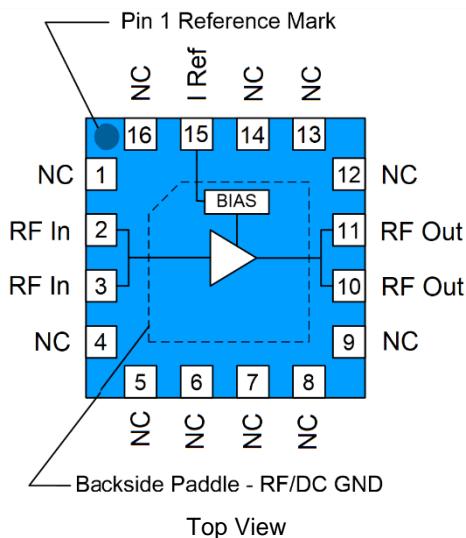

Ordering Information

Part No.	Description
QPA9119	2,500 pieces on a 7" reel (standard)
QPA9119-PCB900	869–960 MHz Evaluation Board
QPA9119-PCB2140	2110–2170 MHz Evaluation Board

Absolute Maximum Ratings

Parameter	Rating
Storage Temperature	-65 to +150 °C
RF Input Power, CW, 50 Ω, T=25 °C	+27 dBm
Device Voltage (V _{CC})	+8 V
Dissipated Power (P _{DISS})	1.7 W

Exceeding any one or a combination of the Absolute Maximum Rating conditions may cause permanent damage to the device. Extended application of Absolute Maximum Rating conditions to the device may reduce device reliability.

Recommended Operating Conditions

Parameter	Min	Typ	Max	Units
Device Voltage (V _{CC})	+4.75	+5	+5.25	V
T _{CASE}	-40		+105	°C
T _j for >10 ⁶ hours MTTF			+175	°C

Electrical specifications are measured at specified test conditions. Specifications are not guaranteed over all recommended operating conditions.

Electrical Specifications

Parameter	Conditions ⁽¹⁾	Min	Typ	Max	Units
Operational Frequency Range		400		4200	MHz
Test Frequency			2140		MHz
Gain		15.5	17.1	18.5	dB
Input Return Loss			14		dB
Output Return Loss			11		dB
Output P1dB		+26.4	+27.2		dBm
Output IP3	P _{out} = +9 dBm/tone, Δf = 1 MHz	+41.0	+43.8		dBm
LTE Channel Power ⁽²⁾	-50 dBc ACLR See Note 2		+18.1		dBm
Noise Figure			4.8		dB
Reference Bias current	Pin 15		7		mA
Quiescent Current, I _{CCQ}	Pins 10, 11	115	130	155	mA
Total Current			137		mA
Thermal Resistance, θ _{JC}	Junction to case			50.3	°C/W

Notes:

1. Test conditions unless otherwise noted: V_{CC} = V_{PD} = +5.0 V, Temp = +25 °C, 50 Ω system.
2. ACLR test set-up: LTE, 20 MHz E-UTRA, +20 MHz offset, PAR = 9.5 dB at 0.01% Probability

S-Parameters

Freq (GHz)	S11 (dB)	S11 (ang)	S21 (dB)	S21 (ang)	S12 (dB)	S12 (ang)	S22 (dB)	S22 (ang)
0.05	-6.62	-174.41	27.28	124.83	-24.82	87.65	-4.37	-172.48
0.10	-6.11	-174.19	23.31	125.16	-36.26	0.46	-2.80	-159.87
0.20	-7.34	-152.53	17.32	131.27	-40.20	9.27	-2.05	-177.15
0.40	-0.95	-162.11	20.48	144.17	-33.75	33.77	-4.17	166.09
0.60	-0.67	-177.80	19.46	120.55	-32.49	22.94	-4.88	167.74
0.80	-0.81	174.16	17.80	105.64	-32.11	18.72	-4.89	167.06
1.00	-0.92	168.52	16.25	94.63	-31.86	16.69	-4.81	164.86
1.20	-1.00	163.75	14.88	85.61	-31.62	15.38	-4.73	162.09
1.40	-1.06	159.42	13.67	77.74	-31.39	14.42	-4.66	158.97
1.60	-1.10	155.28	12.59	70.57	-31.16	13.48	-4.57	155.65
1.80	-1.12	151.20	11.59	63.86	-30.95	12.50	-4.48	152.21
2.00	-1.13	147.13	10.68	57.49	-30.74	11.44	-4.38	148.80
2.20	-1.13	142.97	9.83	51.35	-30.56	10.16	-4.26	145.35
2.40	-1.13	138.79	9.03	45.42	-30.40	8.87	-4.15	142.00
2.60	-1.12	134.61	8.25	39.65	-30.26	7.52	-4.03	138.91
2.80	-1.09	130.44	7.50	34.07	-30.15	5.99	-3.89	136.04
3.00	-1.05	126.28	6.77	28.70	-30.06	4.49	-3.75	133.19
3.20	-1.03	122.34	6.07	23.53	-30.00	3.00	-3.63	130.49
3.40	-1.00	118.66	5.38	18.51	-29.95	1.37	-3.52	128.09
3.60	-0.95	115.17	4.72	13.69	-29.93	-0.17	-3.38	125.84
3.80	-0.91	111.69	4.09	9.01	-29.91	-1.72	-3.25	123.58
4.00	-0.89	109.84	3.55	4.09	-29.84	-3.69	-3.09	118.66
4.20	-0.86	107.48	2.95	-0.05	-29.86	-5.00	-2.99	116.78
4.40	-0.82	105.44	2.38	-3.91	-29.88	-6.15	-2.88	115.15
4.60	-0.79	103.60	1.84	-7.62	-29.91	-7.26	-2.76	113.43
4.80	-0.77	102.20	1.34	-11.12	-29.93	-8.27	-2.68	111.71
5.00	-0.76	100.98	0.87	-14.54	-29.95	-9.25	-2.61	110.10
5.20	-0.75	100.03	0.44	-17.85	-29.97	-10.10	-2.54	108.53
5.40	-0.74	99.00	0.04	-21.17	-29.98	-11.00	-2.47	106.94
5.60	-0.74	98.11	-0.33	-24.43	-29.98	-11.73	-2.41	105.20
5.80	-0.75	97.20	-0.67	-27.76	-29.96	-12.52	-2.36	103.39
6.00	-0.76	96.42	-0.99	-31.12	-29.92	-13.30	-2.32	101.42

Test Conditions: $V_{CC}=+5\text{ V}$, $I_{CO}=130\text{ mA}$ (typ.), Temp.=+25 °C, unmatched 50 Ohm system, reference plane at device leads

869–960 MHz Evaluation Board – QPA9119-PCB900

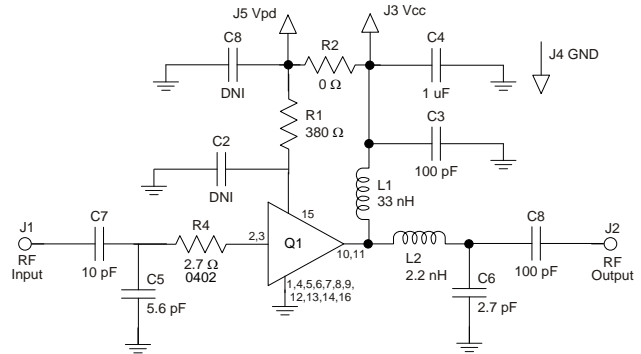
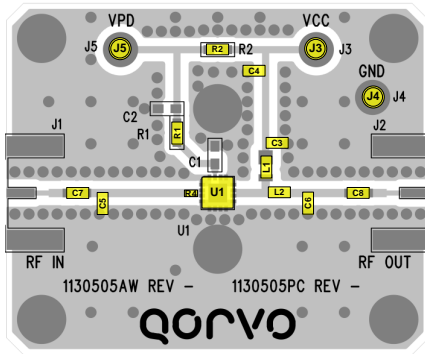

Notes:

1. See Evaluation Board PCB Information for material and stack up.
2. Critical component placement locations:
 - Distance from U1 (left edge) to R4 (right edge): 25 mils (1.2 deg. at 920 MHz)
 - Distance from U1 (left edge) to C5 (right edge): 360 mils (17 deg. at 920 MHz)
 - Distance from U1 (right edge) to L2 (left edge): 120 mils (5.7 deg. at 920 MHz)
 - Distance from U1 (right edge) to C6 (left edge): 347 mils (16.5 deg. at 920 MHz)

Bill of Material – QPA9119-PCB900

Reference Des.	Value	Description	Manuf.	Part Number
-	-	Printed Circuit Board	Qorvo	
U1	-	QPA9119 Amplifier, QFN pkg.	Qorvo	QPA9119
R2	0 Ω	Resistor, Chip, 0603	various	
R4	2.7 Ω	Resistor, Chip, 0402, 1%, 1/16W	various	
R1	380 Ω	Resistor, Chip, 0603, 1%, 1/16W	various	
L2	2.2 nH	Inductor, 0603, +/-0.3 nH	Toko	LL1608-FSL2N2S
L1	33 nH	Inductor, 0805, 5%, Coilcraft CS Series	Coilcraft	0805CS-330XJLB
C7	10 pF	Cap., Chip, 0603, 5%, 50V. NPO/COG	various	
C6	2.7 pF	Cap., Chip, 0603, +/-0.1pF. 200V. NPO/COG NPO/COG	various	
C2, C8	100 pF	Cap., Chip, 0603, 5%, 50V, NPO/COG	various	
C4	1.0 μF	Cap., Chip, 0603, 10%, 10V, X5R	various	
C5	5.6 pF	Cap., Chip, 0603, +/-0.1pF. 200V. NPO/COG	various	

Typical Performance – QPA9119-PCB900

Parameter	Conditions ⁽¹⁾	Typical Value			Units
Frequency		869	920	960	MHz
Gain		21.1	21.2	21.1	dB
Input Return Loss		10	13	17	dB
Output Return Loss		13	12	11	dB
Output P1dB		+28.0	+28.2	+28.3	dBm
OIP3	Pout= +21 dBm/tone, Δf=1 MHz	+43.5	+43.8	+43.5	dBm
LTE Channel Power ⁽²⁾	-50 dBc ACLR	+18.3	+18.7	+18.7	dBm
Noise Figure		6.8	6.7	6.7	dB

Notes:

1. Test conditions unless otherwise noted: V_{CC} = V_{PD} = +5V, I_{CQ} = 130 mA, I_{REF} = 7 mA, Temp.=+25 °C
2. ACLR Test set-up: LTE, 20 MHz E-UTRA, +20 MHz offset, PAR = 9.5 dB at 0.01% Probability

Performance Plots – QPA9119-PCB900

Test conditions unless otherwise noted: $V_{CC} = V_{PD} = +5V$, $I_{CQ} = 130\text{ mA}$, $I_{REF} = 7\text{ mA}$, $Temp. = +25^\circ\text{C}$

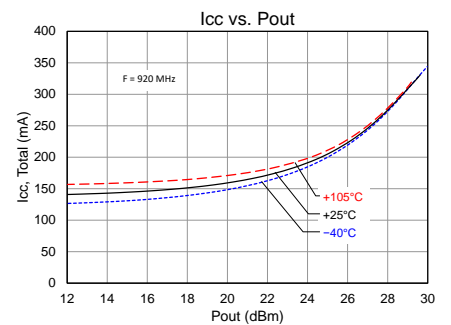
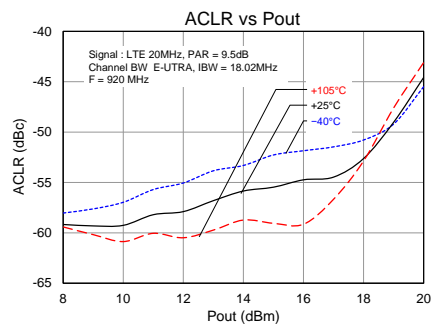
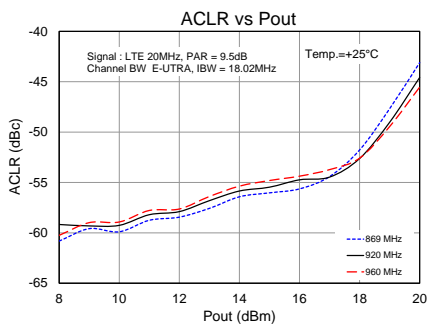
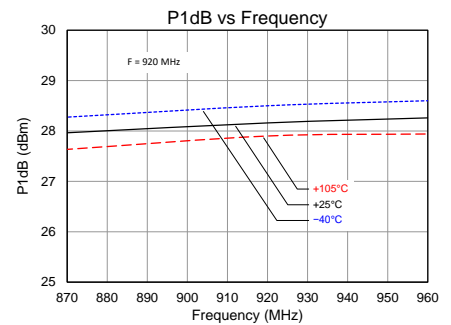
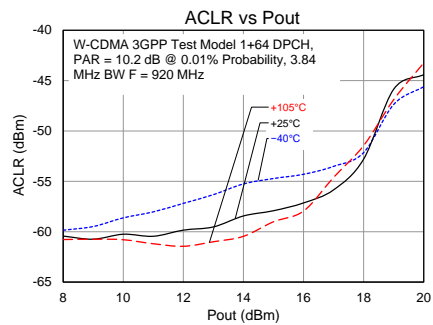
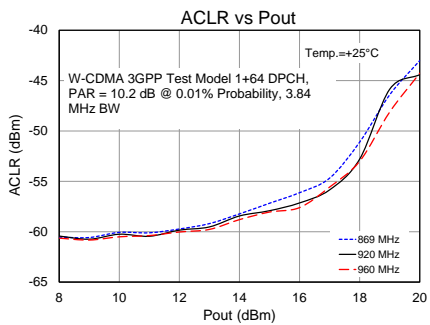
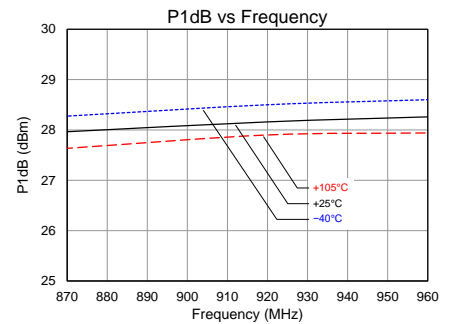
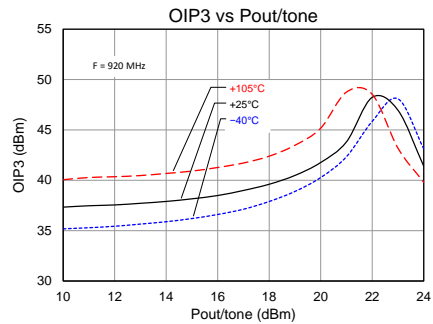
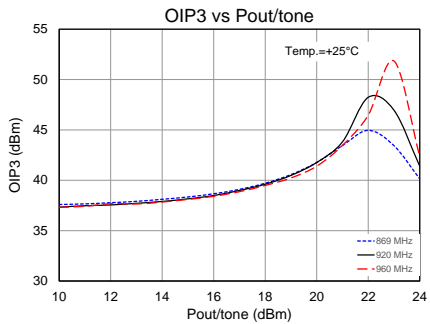
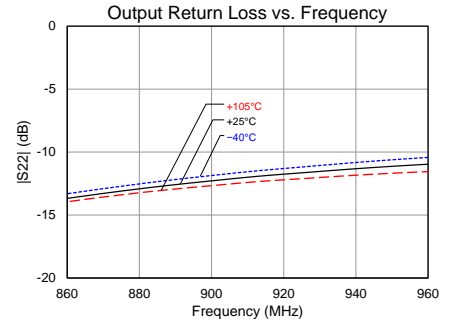
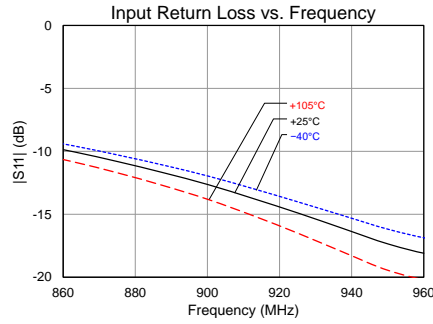
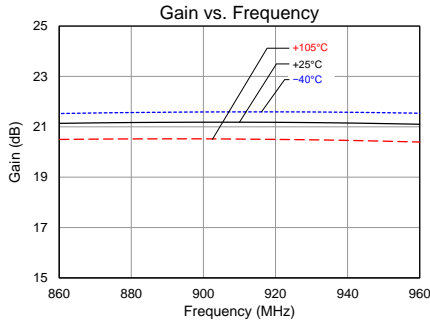

2110–2170 MHz Evaluation Board – QPA9119-PCB2140

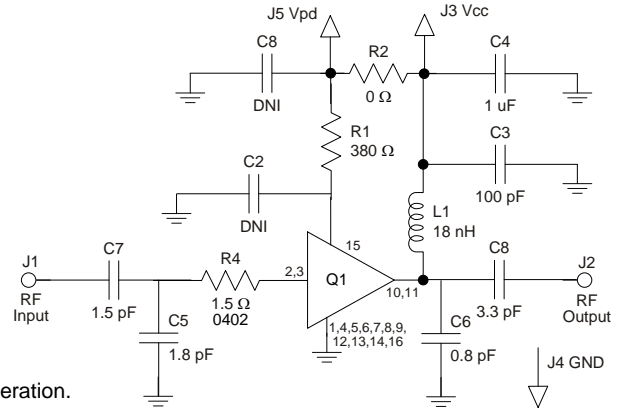
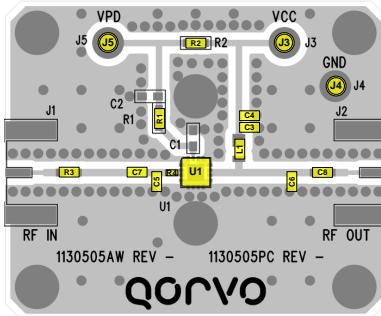

Notes:

1. See Evaluation Board PCB Information for material and stack up.
2. The recommended component values are dependent upon the frequency of operation.
3. All components are of 0603 size unless stated on the schematic.
4. Critical component placement locations:
 - Distance from U1 (left edge) to R4 (right edge): 32 mils (3.6 deg. at 2140 MHz)
 - Distance from U1 (left edge) to C5 (right edge): 70 mils (7.8 deg. at 2140 MHz)
 - Distance from U1 (left edge) to C7 (right edge): 152 mils (16.8 deg. at 2140 MHz)
 - Distance from U1 (right edge) to C8 (left edge): 380 mils (42.0 deg. at 2140 MHz)
 - Distance from U1 (right edge) to C6 (left edge): 305 mils (33.7 deg. at 2140 MHz)

Bill of Material QPA9119-PCB2140

Reference Des.	Value	Description	Manuf.	Part Number
n/a	n/a	Printed Circuit Board	Qorvo	
U1	n/a	QPA9119 Amplifier, QFN pkg.	Qorvo	QPA9119
R2	0 Ω	Resistor, Chip, 0603	various	
R4	1.5 Ω	Resistor, Chip, 0402, 1%, 1/16W	various	
R1	380 Ω	Resistor, Chip, 0603, 1%, 1/16W	various	
C3	100 pF	Cap., Chip, 0603, 5%, 50V, NPO/COG	various	
L1	18 nH	Inductor, 0805, 5%, Coilcraft CS Series	Coilcraft	0805CS-180XJLB
C7	1.5 pF	Cap., Chip, 0603, +/-0.1pF. 200V. NPO/COG 5%,	various	
C6	0.8 pF	Cap., Chip, 0603, +/-0.1pF. 200V. NPO/COG	various	
C8	3.3 pF	Cap., Chip, 0603, +/-0.1pF. 200V. NPO/COG	various	
C4	1.0 μF	Cap., Chip, 0603, 10%, 10V, X5R	various	
C5	1.8 pF	Cap., Chip, 0603, +/-0.1pF. 200V. NPO/COG	various	

Typical Performance – QPA9119-PCB2140

Parameter	Conditions	Typical Value			Units
Frequency		2110	2140	2170	MHz
Gain		17.1	17.1	17.0	dB
Input Return Loss		13	14	14	dB
Output Return Loss		12	11	11	dB
Output P1dB		+27.4	+27.2	+27.1	dBm
OIP3	Pout= +13 dBm/tone, Δf=1 MHz	+43.5	+43.8	+43.6	dBm
LTE Channel Power ⁽²⁾	-50 dBc ACLR	+18.2	+18.1	+18.4	dBm
Noise Figure		4.8	4.8	4.8	dB

Notes:

1. Test Conditions: $V_{CC} = V_{PD} = +5V$, $I_{CO} = 130\text{ mA}$, $I_{REF} = 7\text{ mA}$, Temp.=+25 °C
2. ACLR Test set-up: LTE, 1-CH E-UTRA, +20 MHz offset, PAR = 9.5 dB at 0.01% Probability

Performance Plots – QPA9119-PCB2140

Test conditions unless otherwise noted: $V_{CC} = V_{PD} = +5V$, $I_{CQ} = 130\text{ mA}$, $I_{REF} = 7\text{ mA}$, $Temp. = +25^\circ\text{C}$

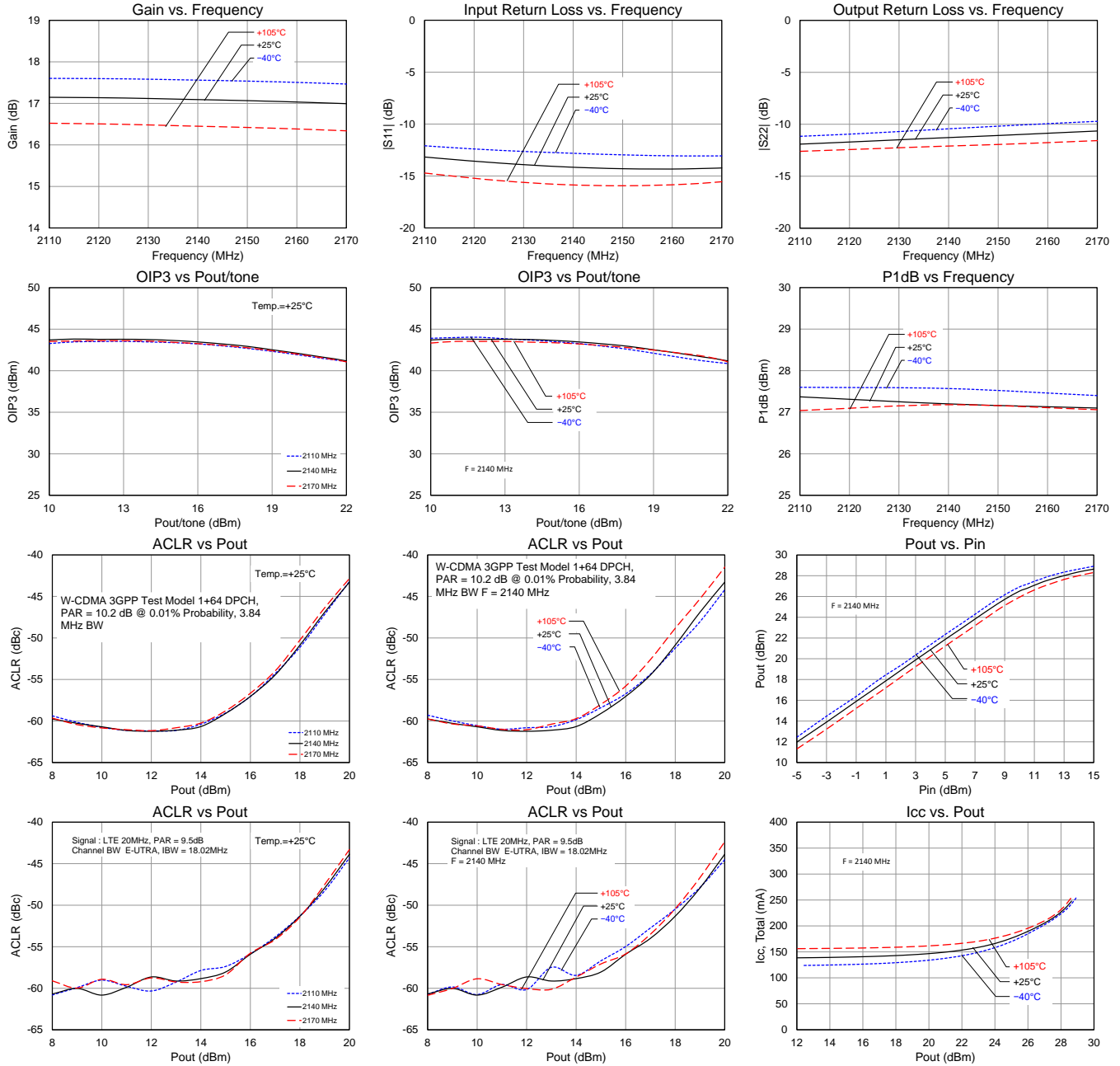

2300 – 2700 MHz Reference Design

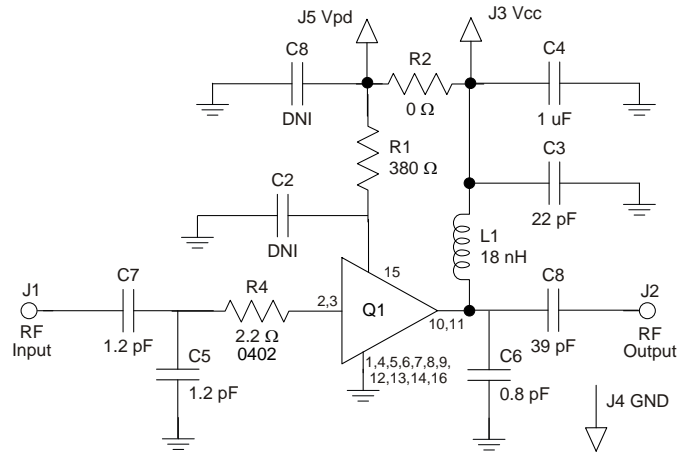
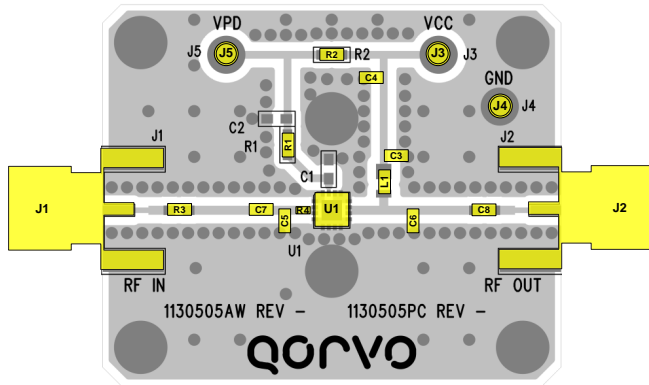

Notes:

1. See Evaluation Board PCB Information for material and stack up.
2. Critical component placement locations:
 - Distance between U1 (left edge) to R4 (right edge): 15 mil
 - Distance between U1 (left edge) to C5 (right edge): 80 mil
 - Distance between U1 (left edge) to C7 (right edge): 130 mil
 - Distance between U1 (right edge) to C6 (left edge): 130 mil

Bill of Material – 2300 ~ 2700 MHz Reference Design

Ref. Des.	Value	Description	Manuf.	Part Number
-	-	Printed Circuit Board	Qorvo	
U1	-	0.5 W High Linearity Amplifier	Qorvo	QPA9119
R1	380 Ω	Res., Chip, 0603, +/-1%, 1/10W	various	
R2, R3	0 Ω	Res., Chip, 0603	various	
C5, C7	1.2 pF	CAP, 0603, +/-0.1pF. 200V. NPO/COG	various	
C6	0.8 pF	CAP, 0603, +/-0.1pF. 200V. NPO/COG	various	
C8	39 pF	Cap., Chip, 0603, +/-5%. 50V NPO/COG	various	
C3	22 pF	Cap., Chip, 0603, +/-5%. 50V NPO/COG	various	
R4	2.2 Ω	Res., Chip, 0402, +/-1%, 1/10W	various	
C4	1.0 μF	CAP, 0603, 10%, X5R, 10V	various	
L1	18 nH	Inductor, 0805, 5%, Coilcraft CS series	Coilcraft	0805CS-180XJLB

Typical Performance 2300~2700 MHz Reference Design

Parameter	Conditions	Typical Value					Units
		2300	2400	2500	2600	2700	
Frequency		2300	2400	2500	2600	2700	MHz
Gain		14.1	14.3	14.3	14.1	13.7	dB
Input Return Loss		7.6	10	13	13	11	dB
Output Return Loss		9.1	8.8	8.6	8.3	8.2	dB
Output P1dB		+27.3	+27.6	+27.6	+27.3	+27.1	dBm
Output IP3	Pout= +15 dBm/tone, Δf= 1 MHz	+46.1	+44.5	+44.1	+44.5	+44.9	dBm
Quiescent Collector Current, I _{CQ}		130					mA

Notes:

1. Test Conditions: V_{CC} = V_{PD} = +5V, I_{CQ} = 130 mA, I_{REF} = 7 mA, Temp.=+25 °C

Performance Plots 2300 – 2700 MHz Reference Design

Test Conditions: $V_{CC} = V_{PD} = +5V$, $I_{CQ} = 130\text{ mA}$, $I_{REF} = 7\text{ mA}$, $Temp. = +25^\circ\text{C}$

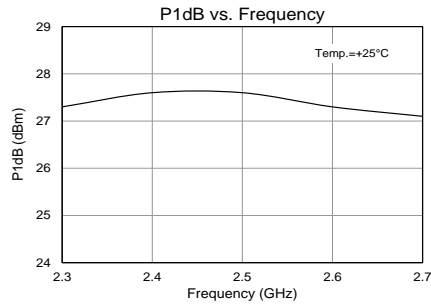
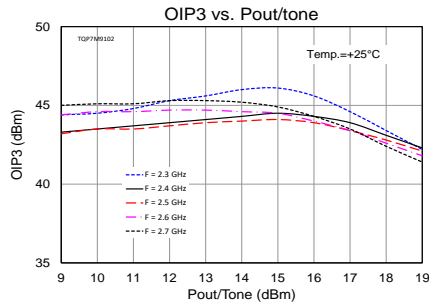
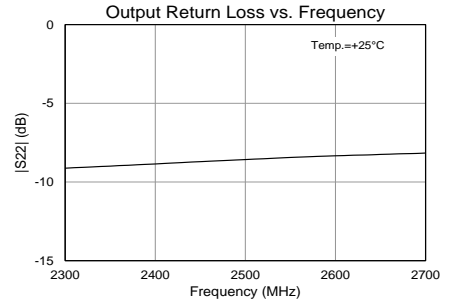
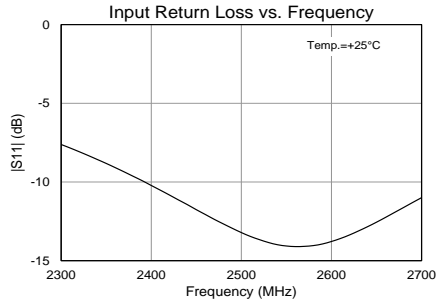
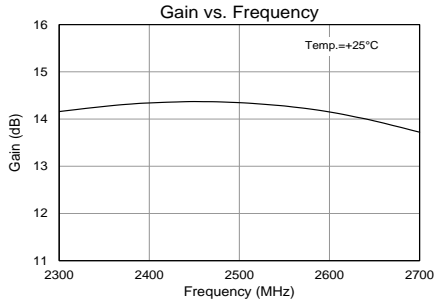

Pad Configuration and Description

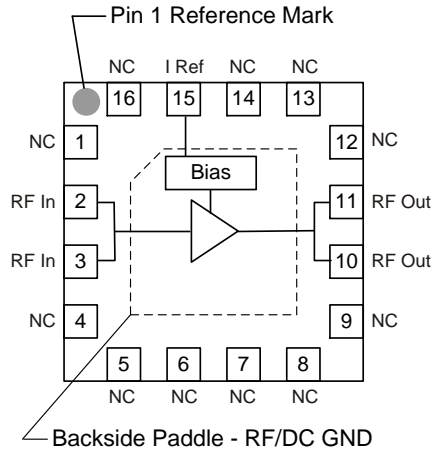

Top View

Pad No.	Label	Description
1, 4, 5, 6, 7, 8, 9, 12, 13, 14, 16	NC	No electrical connection. Land pads should be provided for PCB mounting integrity.
2, 3	RF IN	RF input. External DC Block required. Requires conjugate match for optimal performance.
10, 11	RF OUT / V _{CC}	RF output. External DC Block and bias voltage required. Requires matching.
15	I REF	Sets the bias current for the amp. Also can be used to power down device.
Backside Paddle	GND	RF/DC ground. Use recommended via pattern to minimize inductance and thermal resistance. See PCB Mounting Pattern for suggested footprint.

Evaluation Board PCB Information

PC Board Layout

PCB 1130505 Material (stack up)

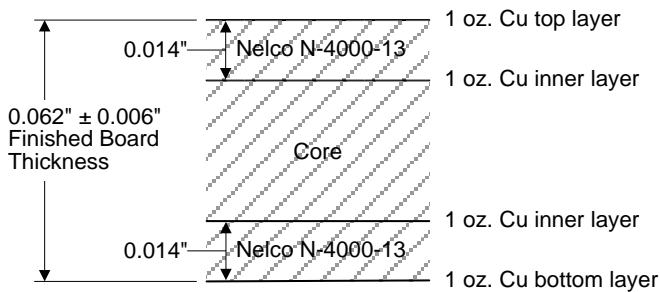

50-ohm line dimensions: width = 0.029", spacing = 0.029"

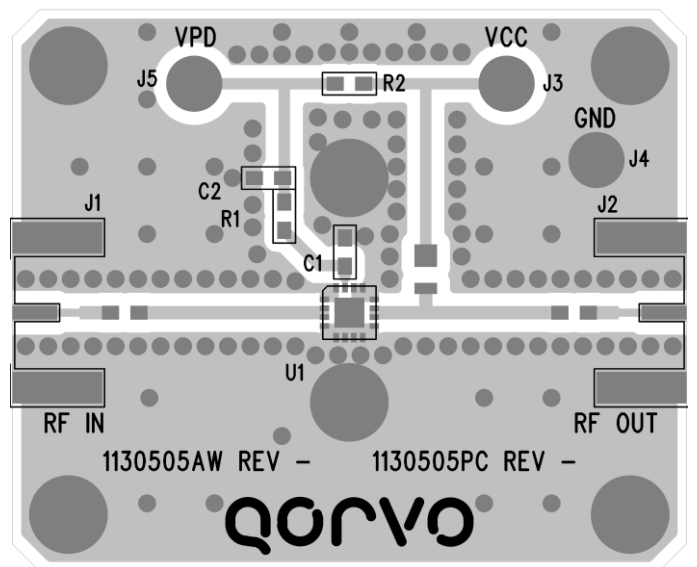

Package Marking and Dimensions

Marking: Part Number – 9119
Date Code – YYWW
Lot Code – AaXXXX

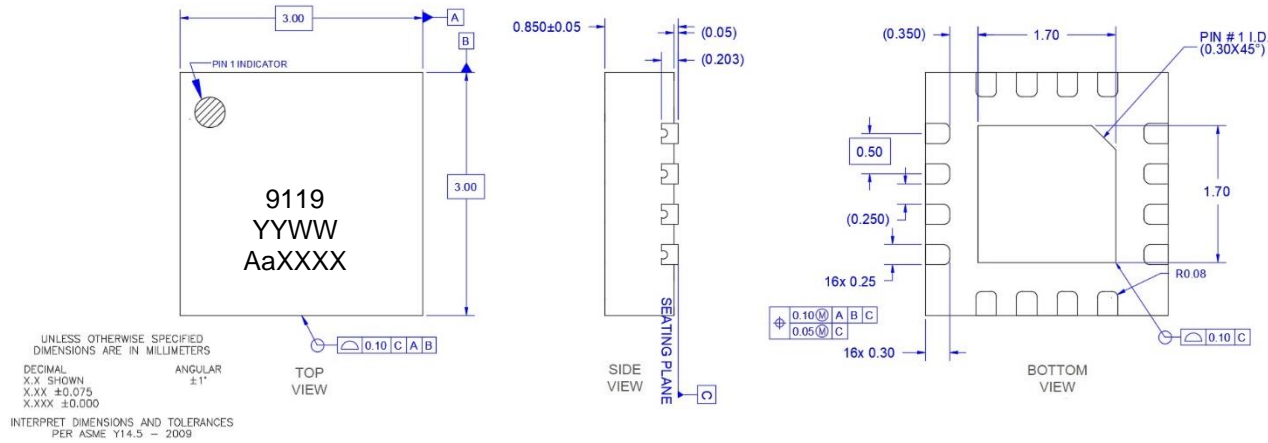

- Notes:
1. All dimensions are in millimeters. Angles are in degrees.
 2. The terminal #1 identifier and terminal numbering conform to JESD 95-1 SPP-012.
 3. Contact plating: NiPdAu

PCB Mounting Pattern

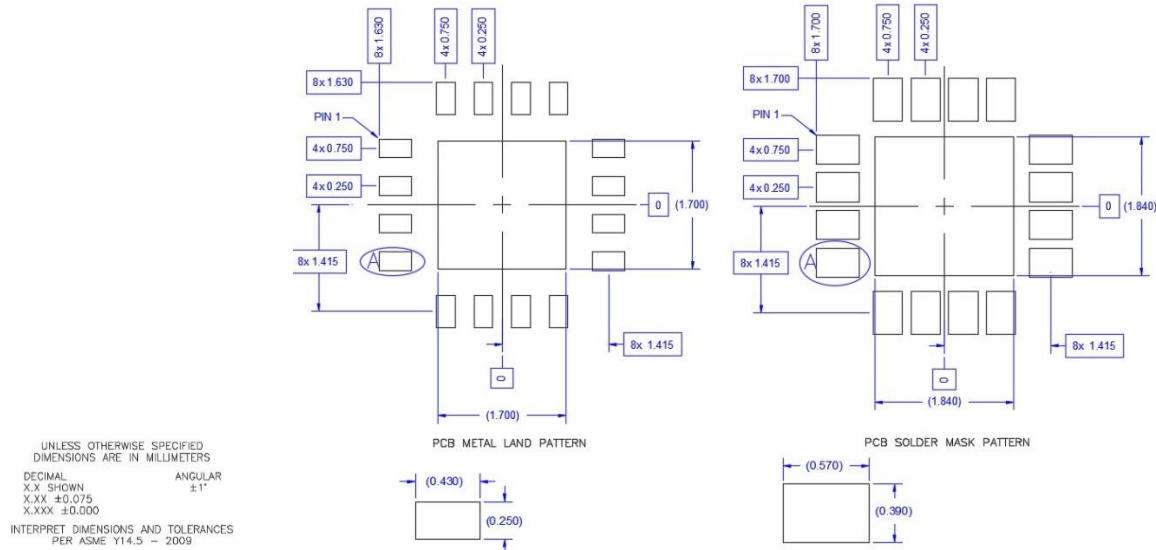

- Notes:
1. All dimensions are in millimeters. Angles are in degrees.
 2. Use 1 oz. copper minimum for top and bottom layer metal.
 3. Vias are required under the backside paddle of this device for proper RF/DC grounding and thermal dissipation. We recommend a 0.35mm (#80/.0135") diameter bit for drilling via holes and a final plated thru diameter of 0.25 mm (0.10").
 4. Ensure good package backside paddle solder attach for reliable operation and best electrical performance.

Tape and Reel Information – Carrier and Cover Tape Dimensions

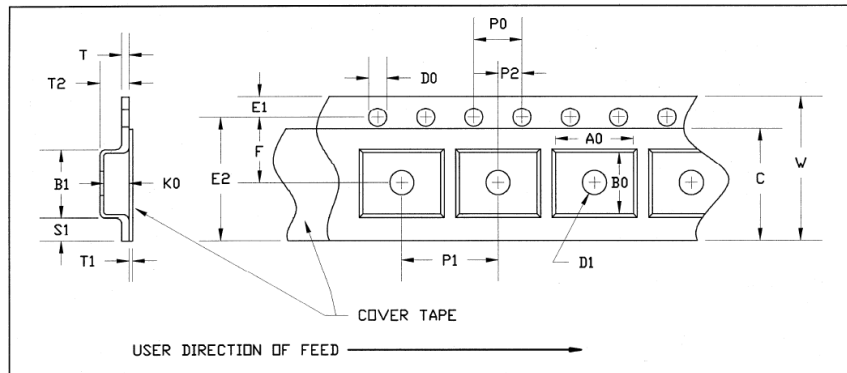
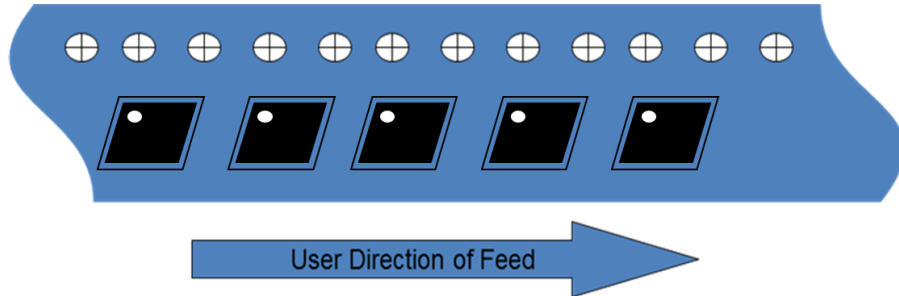

Feature	Measure	Symbol	Size (in)	Size (mm)
Cavity	Length	A0	0.126	3.20
	Width	B0	0.126	3.20
	Depth	K0	0.039	1.00
	Pitch	P1	0.157	4.00
Centerline Distance	Cavity to Perforation - Length Direction	P2	0.079	2.00
	Cavity to Perforation - Width Direction	F	0.217	5.50
Cover Tape	Width (Reverence Only)	C	0.362	9.20
Carrier Tape	Width	W	0.472	12.00

Tape and Reel Information – Reel Dimensions

Standard T/R size = 2500 pieces on a 7" reel.

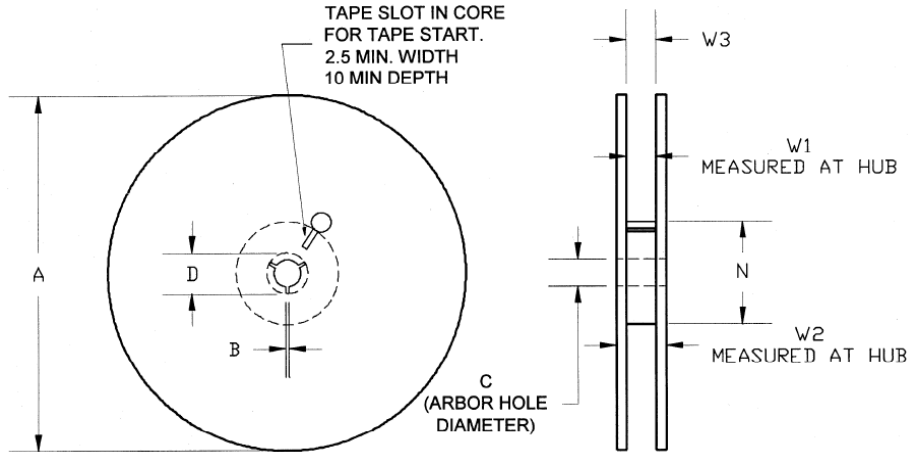

Feature	Measure	Symbol	Size (in)	Size (mm)
Flange	Diameter	A	6.969	177.0
	Thickness	W2	0.717	18.2
	Space Between Flange	W1	0.504	12.8
Hub	Outer Diameter	N	2.283	58.0
	Arbor Hole Diameter	C	0.512	13.0
	Key Slit Width	B	0.079	2.0
	Key Slit Diameter	D	0.795	20.2

Tape and Reel Information – Tape Length and Label Placement

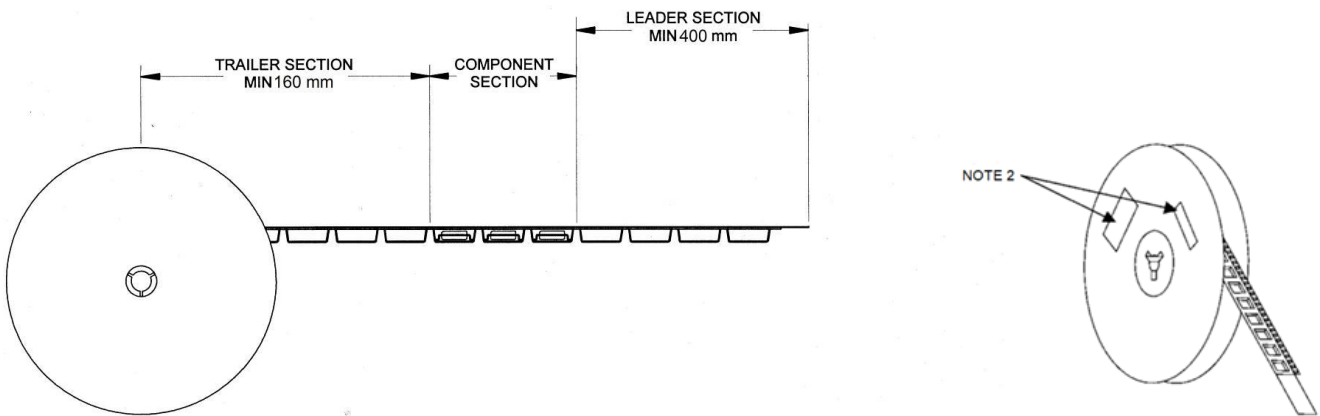

- Notes:
1. Empty part cavities at the trailing and leading ends are sealed with cover tape. See EIA 481-1-A.
 2. Labels are placed on the flange opposite the sprockets in the carrier tape.

Handling Precautions

Parameter	Rating	Standard
ESD – Human Body Model (HBM)	Class 1C	ESDA / JEDEC JS-001-2012
ESD – Charged Device Model (CDM)	Class C3	JEDEC JESD22-C101F
MSL – Moisture Sensitivity Level	Level 1	IPC/JEDEC J-STD-020



Caution!
ESD-Sensitive Device

Solderability

Compatible with both lead-free (260°C max. reflow temp.) and tin/lead (245°C max. reflow temp.) soldering processes. Solder profiles available upon request.

Contact plating: NiPdAu

RoHS Compliance

This part is compliant with 2011/65/EU RoHS directive (Restrictions on the Use of Certain Hazardous Substances in Electrical and Electronic Equipment) as amended by Directive 2015/863/EU.

This product also has the following attributes:

- Lead Free
- Halogen Free (Chlorine, Bromine)
- Antimony Free
- TBBP-A (C₁₅H₁₂Br₄O₂) Free
- PFOS Free
- SVHC Free



Contact Information

For the latest specifications, additional product information, worldwide sales and distribution locations:

Web: www.qorvo.com

Tel: 1-844-890-8163

Email: customer.support@qorvo.com

Important Notice

The information contained herein is believed to be reliable; however, Qorvo makes no warranties regarding the information contained herein and assumes no responsibility or liability whatsoever for the use of the information contained herein. All information contained herein is subject to change without notice. Customers should obtain and verify the latest relevant information before placing orders for Qorvo products. The information contained herein or any use of such information does not grant, explicitly or implicitly, to any party any patent rights, licenses, or any other intellectual property rights, whether with regard to such information itself or anything described by such information. **THIS INFORMATION DOES NOT CONSTITUTE A WARRANTY WITH RESPECT TO THE PRODUCTS DESCRIBED HEREIN, AND QORVO HEREBY DISCLAIMS ANY AND ALL WARRANTIES WITH RESPECT TO SUCH PRODUCTS WHETHER EXPRESS OR IMPLIED BY LAW, COURSE OF DEALING, COURSE OF PERFORMANCE, USAGE OF TRADE OR OTHERWISE, INCLUDING THE IMPLIED WARRANTIES OF MERCHANTABILITY AND FITNESS FOR A PARTICULAR PURPOSE.**

Without limiting the generality of the foregoing, Qorvo products are not warranted or authorized for use as critical components in medical, life-saving, or life-sustaining applications, or other applications where a failure would reasonably be expected to cause severe personal injury or death.

Copyright 2025 © Qorvo, Inc. | Qorvo is a registered trademark of Qorvo, Inc.