

## General Description

The QPB1006 is a high power connectorized SSPA module with bias circuit card suitable for installation into OEM assemblies. The amplifier requires +28 Volts DC and customer supplied thermal management. The device is an excellent candidate for high power test equipment, communications, jamming applications, or any application requiring capability for simultaneous power amplification of signals across the 2.0 – 7.5 GHz spectrum.

The QPB1006 incorporates Qorvo high efficiency GaN MMICs, spatially combined in a compact structure to achieve robust, high performance power amplification across the 2.0 – 7.5 GHz frequency range.

The included bias circuit card assembly provides and sequences all required DC voltages from a single customer supplied +28 volt input. Mute and pulse functionality, as well as a summary fault output are available. Individual device current monitoring in analog format is also available.

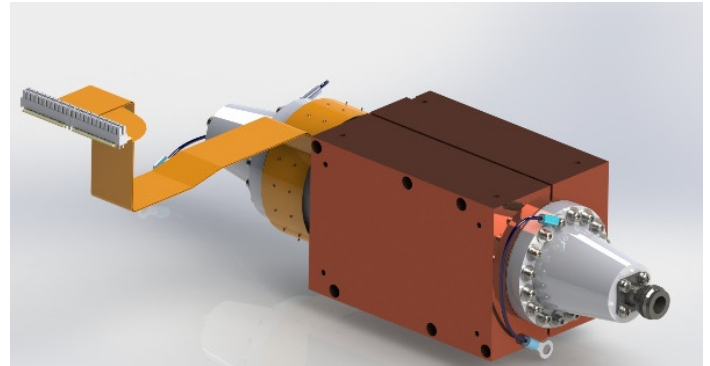

## Product Features

- Frequency: 2.0 – 7.5 GHz
- Saturated Output Power: 150 watts (nom.)
- Small Signal Gain: 30 dB
- Bias Conditions: +28 V single supply,  $I_{DQ} = 9.6A$
- Included gate and drain voltage generation
- Included gate and drain voltage sequencing

*Performance characteristics vary across the product's operating band. Refer to the electrical specification table and data plots for details, including variance across operating temperature.*

## Functional Block Diagram

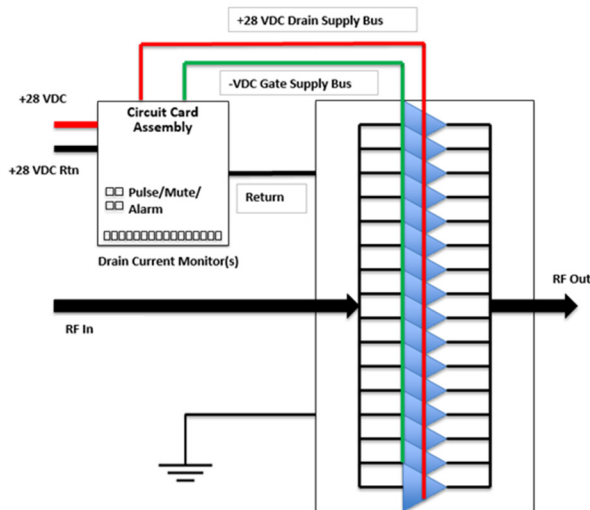

## Applications

- Jamming
- Radar
- Military Communications
- Defense Communications
- Test & Measurement
- EMI Testing

## Ordering Information

Part No.	ECCN	Description
QPB1006	3A001.b.4.b.1	2.0 – 7.5 GHz 150 Watt Amplifier



### Absolute Maximum Ratings

Parameter	Rating
RF Input Power, CW, 50 Ω, T <sub>CASE</sub> =25 °C	+28 dBm
Load VSWR	3.0:1
Device Voltage (V <sub>DD</sub> )	+29 V
Dissipated Power (P <sub>DISS</sub> )	700 W
Storage Temperature	-55 to +100 °C

Exceeding any one or a combination of the Absolute Maximum Rating conditions may cause permanent damage to the device. Extended application of Absolute Maximum Rating conditions to the device may reduce device reliability.

### Recommended Operating Conditions

Parameter	Min	Typ	Max	Units
Voltage (V <sub>DC</sub> )		+28		V
Operating Temperature	-40	+25	+71	°C
Quiescent Current (I <sub>dq</sub> )	8.0	9.6	12.0	A

Electrical specifications are measured at specified test conditions. Specifications are not guaranteed over all recommended operating conditions.



## Electrical Specifications

Please reference data plots for more details.

Parameter	Conditions <sup>(1)</sup>	Min	Typ	Max	Units
Operational Frequency Range		2.0		7.5	GHz
Output Power (P <sub>IN</sub> = 28 dBm)	2.0 GHz		52.2		dBm
	4.0 GHz		51.7		dBm
	6.0 GHz		51.7		dBm
	7.5 GHz		50.7		dBm
Power Added Efficiency (P <sub>IN</sub> = 28 dBm)	2.0 GHz		35.6		%
	4.0 GHz		28.4		%
	6.0 GHz		25.5		%
	7.5 GHz		22.0		%
Small Signal Gain	2.0 GHz		33.2		dB
	4.0 GHz		33.2		dB
	6.0 GHz		32.6		dB
	7.5 GHz		30.1		dB
Small Signal Gain Flatness			2.6		dB
Input Return Loss (average)			See plot		dB
Output 2 <sup>nd</sup> Harmonic	F <sub>0</sub> = 2 – 7.5 GHz, P <sub>IN</sub> = 28 dBm		See plot		dBc
Output 3 <sup>rd</sup> Harmonic	F <sub>0</sub> = 2 – 7.5 GHz, P <sub>IN</sub> = 28 dBm		See plot		dBc
Non-Harmonic Spurious	F <sub>0</sub> = 2 – 7.5 GHz, P <sub>IN</sub> = 28 dBm			-60	dBc
DC Input Power (average)			590		W
Unit Weight	Spatium Only		13.40 (6.08)		Lbs. (kg)
Unit Weight	Spatium plus Bias Card		13.65 (6.19)		Lbs. (kg)

Notes:

1. Test conditions unless otherwise noted: V<sub>DC</sub> = +28 V, Outer Clamp Temperature = +25 °C, 50 Ohm system

**Performance Plots – QPB1006 Large Signal, Small Signal, Harmonics**

Test conditions unless otherwise noted:  $V_{DC} = +28\text{ V}$ , Outer Clamp Temperature =  $+25\text{ }^{\circ}\text{C}$ , 50 Ohm system

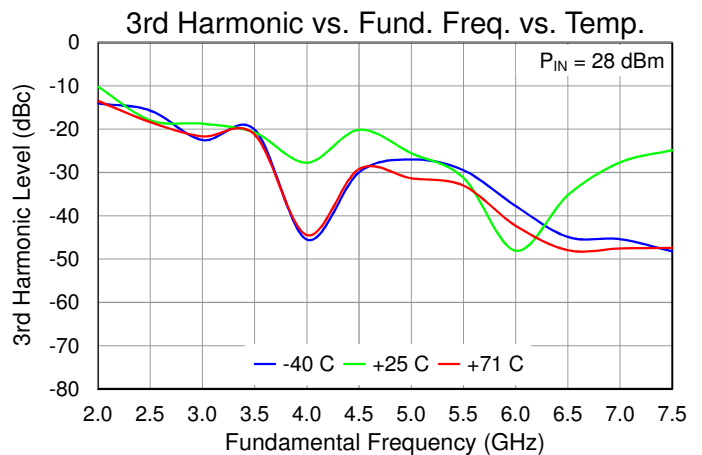
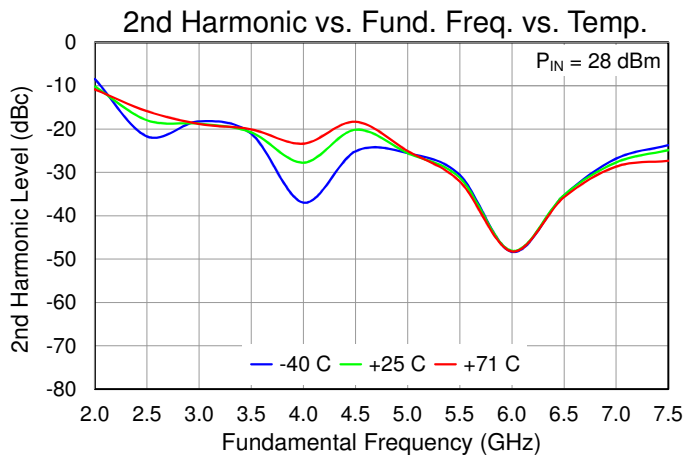
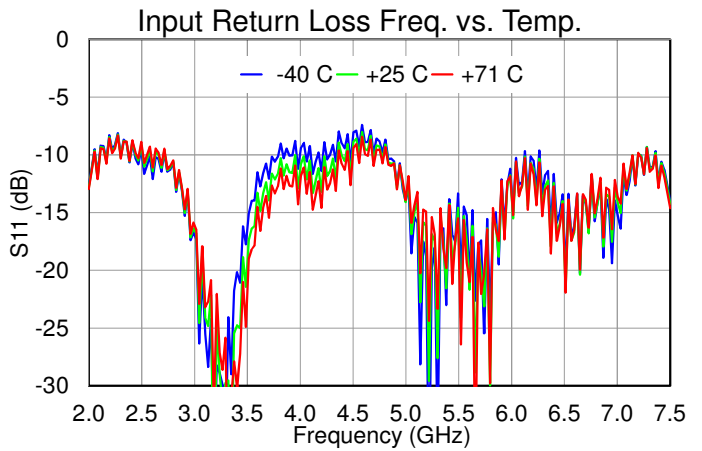
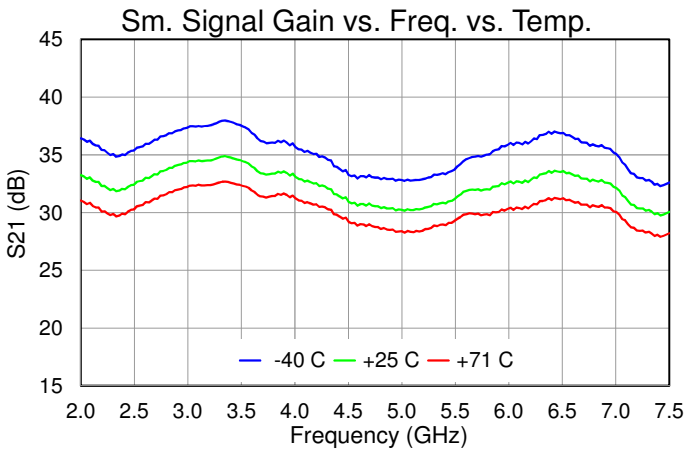
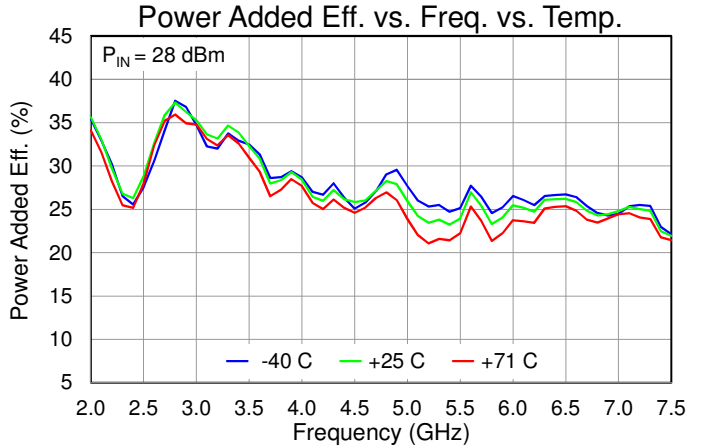
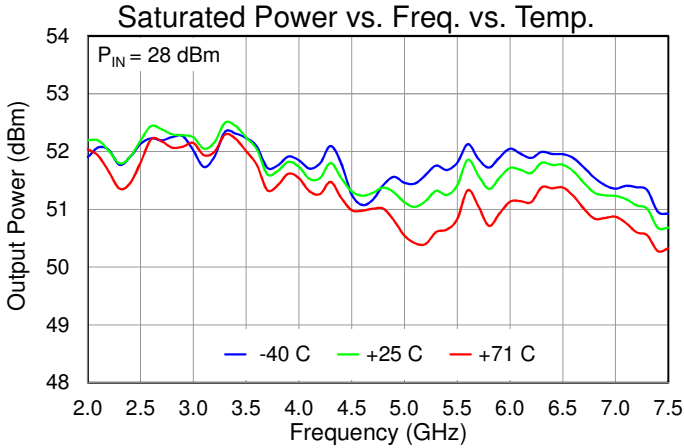

**Performance Plots – QPB1006 Large Signal**

Test conditions unless otherwise noted:  $V_{DC} = +28\text{ V}$ , Outer Clamp Temperature =  $+25\text{ }^\circ\text{C}$ , 50 Ohm system

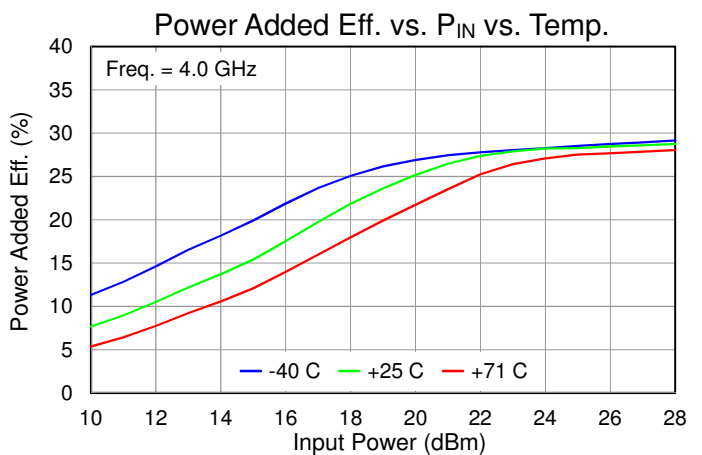
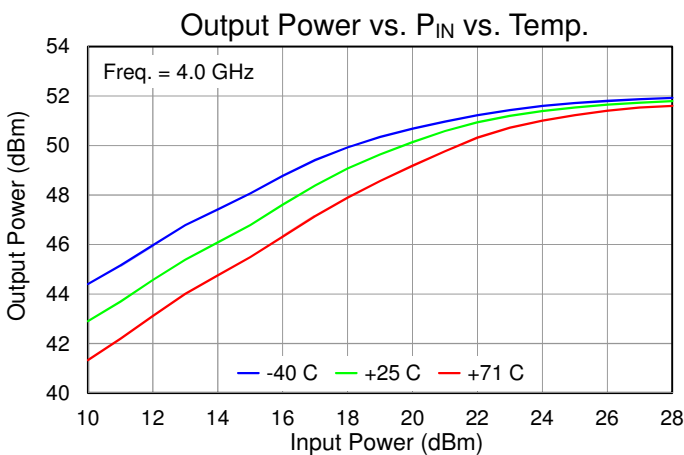
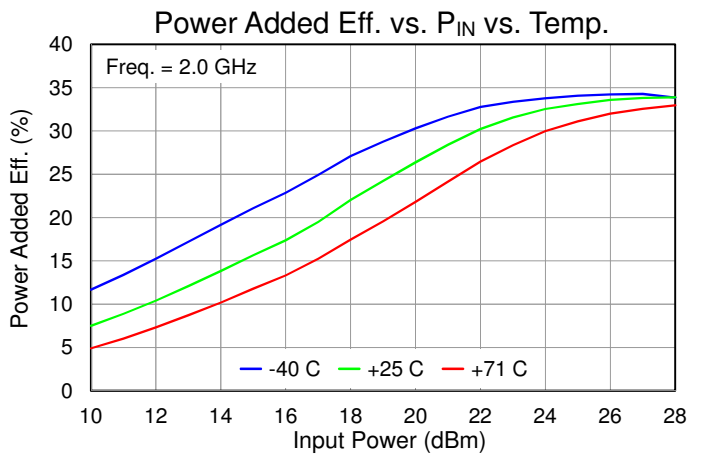
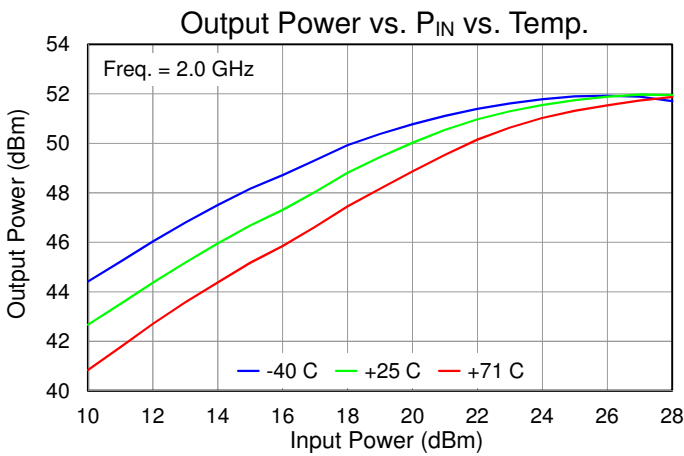
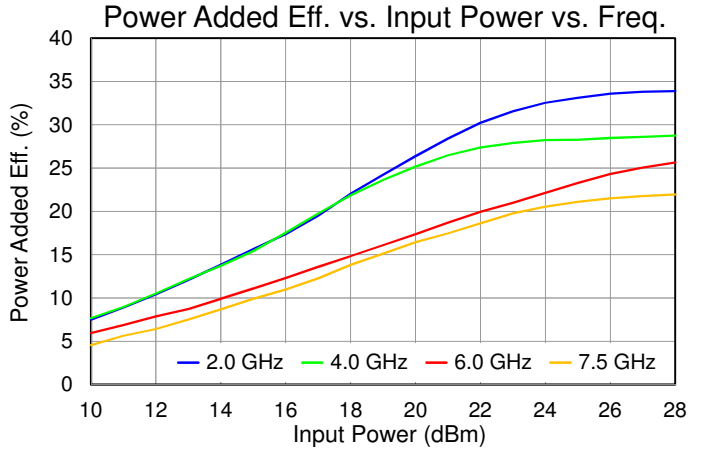
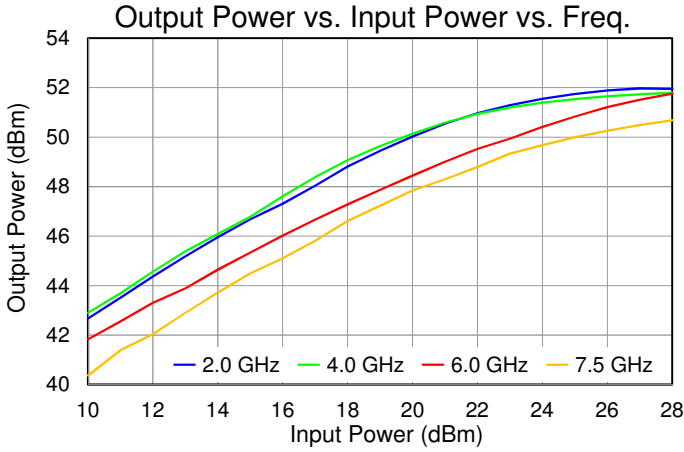

**Performance Plots – QPB1006 Large Signal**

Test conditions unless otherwise noted:  $V_{DC} = +28\text{ V}$ , Outer Clamp Temperature =  $+25\text{ }^{\circ}\text{C}$ , 50 Ohm system

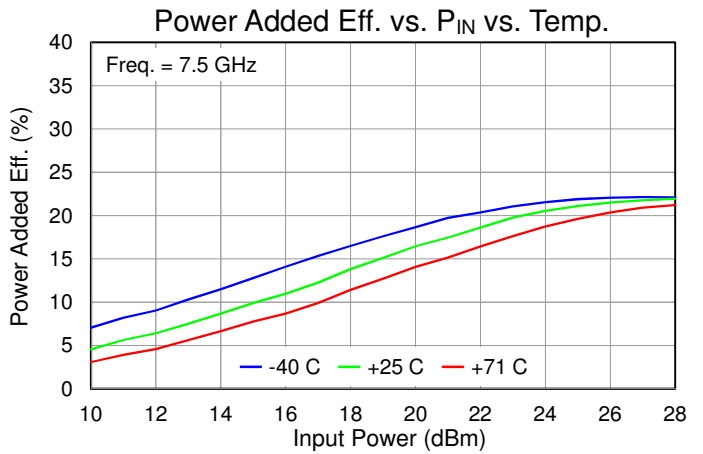
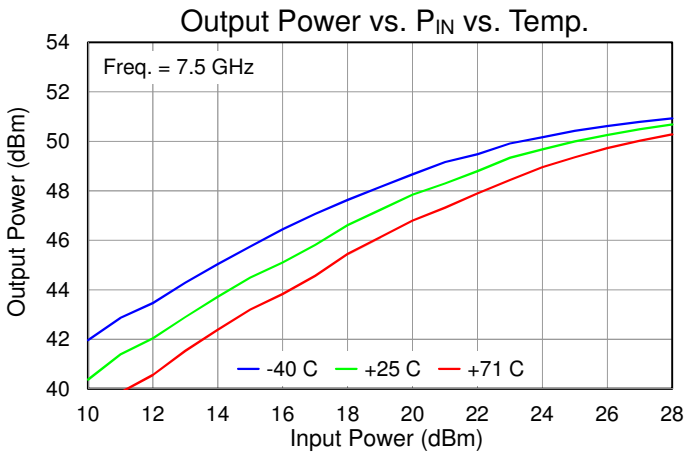
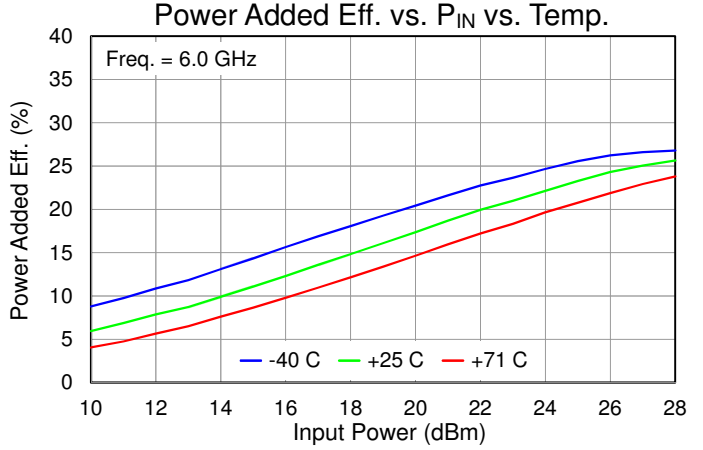
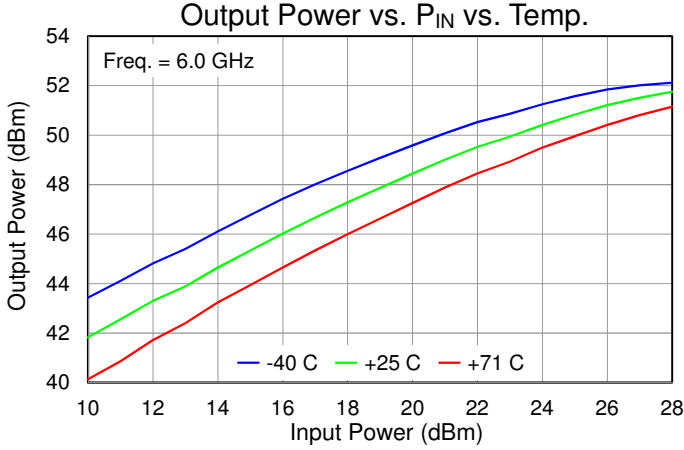

**Block Diagram and Description**

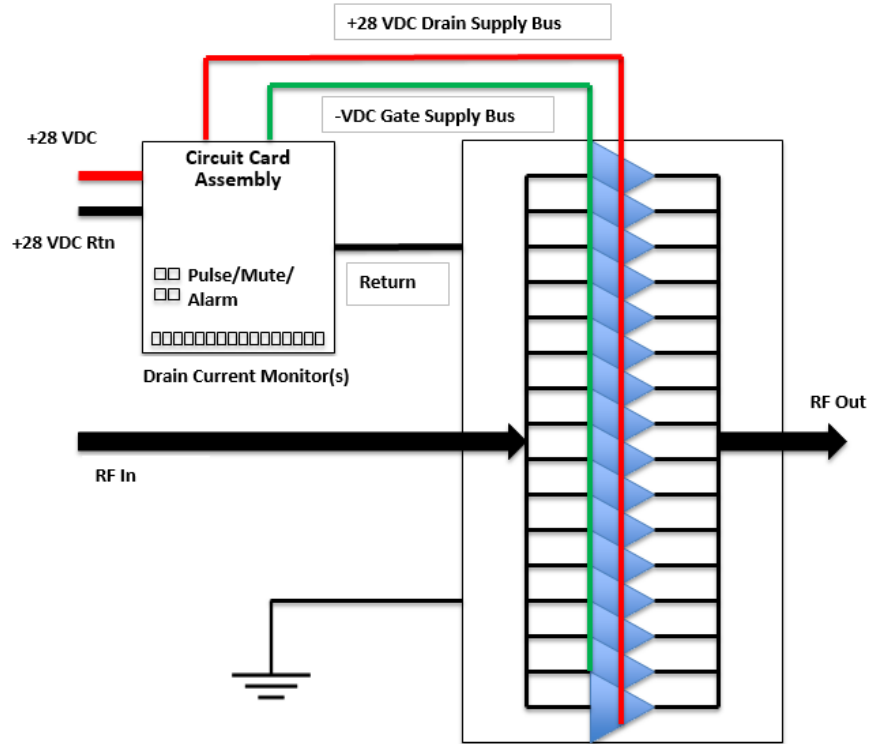

I/O Port	Label	Description
RF In	N/A	SMA (F) RF Input
RF Out	N/A	TNC (F) High Power RF Output
+28 VDC	N/A	Six 14 Ga x 8" Red Wires Ring Lug #10 Stud Terminated
+28 VDC Return	N/A	Six 14 Ga x 8" Black Wires Ring Lug #10 Stud Terminated

## Package Marking and Dimensions

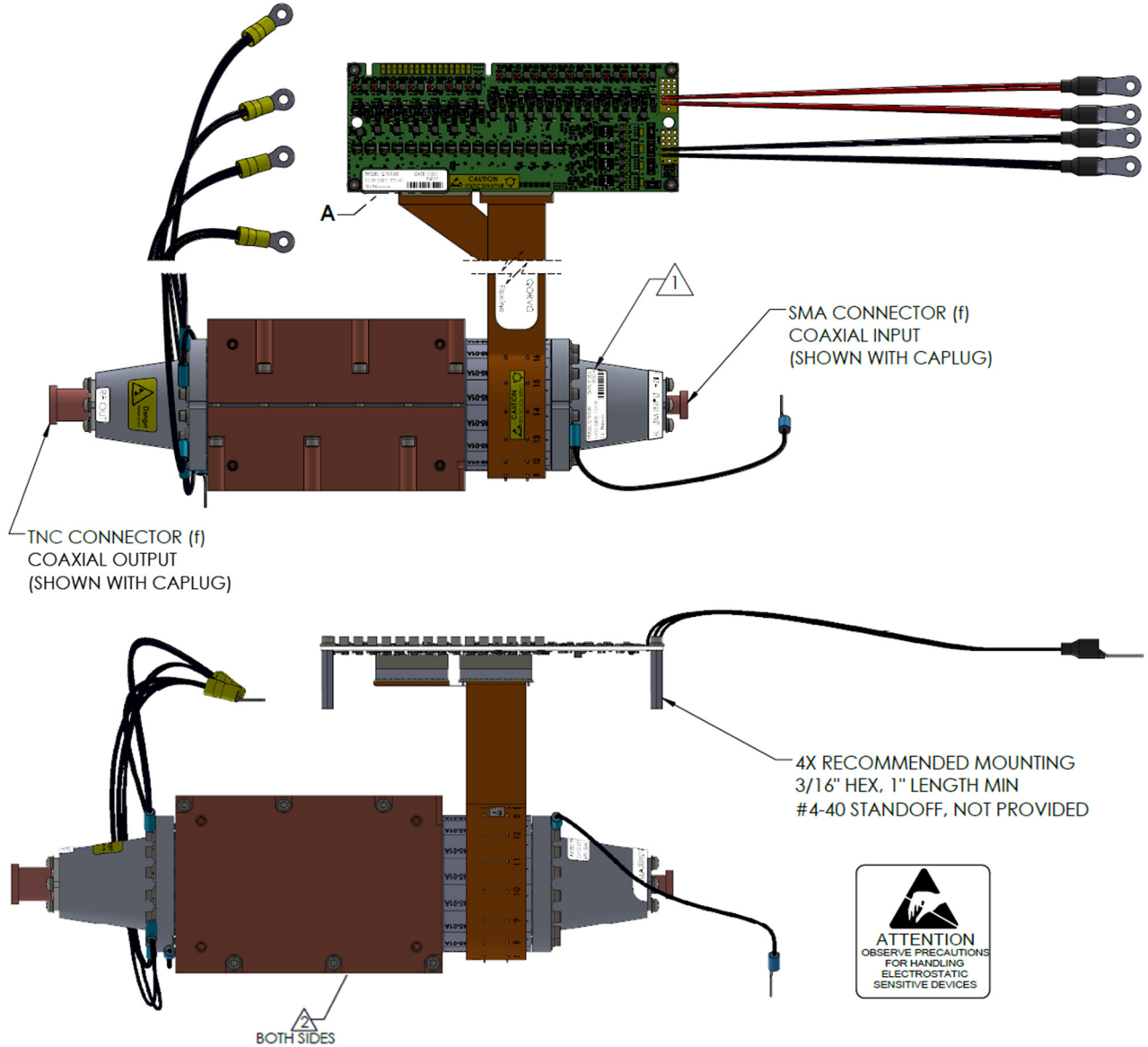

1 LABELS ARE IDENTICAL. ENSURE SERIAL NUMBER IS THE SAME ON BOTH UNITS FOR MATCH SET.  
 SN: \* \* \* \* \*

└─ BATCH I.D.  
 └─ WORK WEEK  
 └─ CALENDAR YEAR  
 └─ MANUFACTURER

2 ADEQUATE HEATSINK REQUIRED ON INDICATED SURFACES OF CLAMP.

MODEL: QPB1006	DATE CODE: WWYY
CAGE CODE: 1CVM1	
SN: Mxxxxxxx	

1 2X DETAIL A

Units in INCHES



## Package Marking and Dimensions (continued)

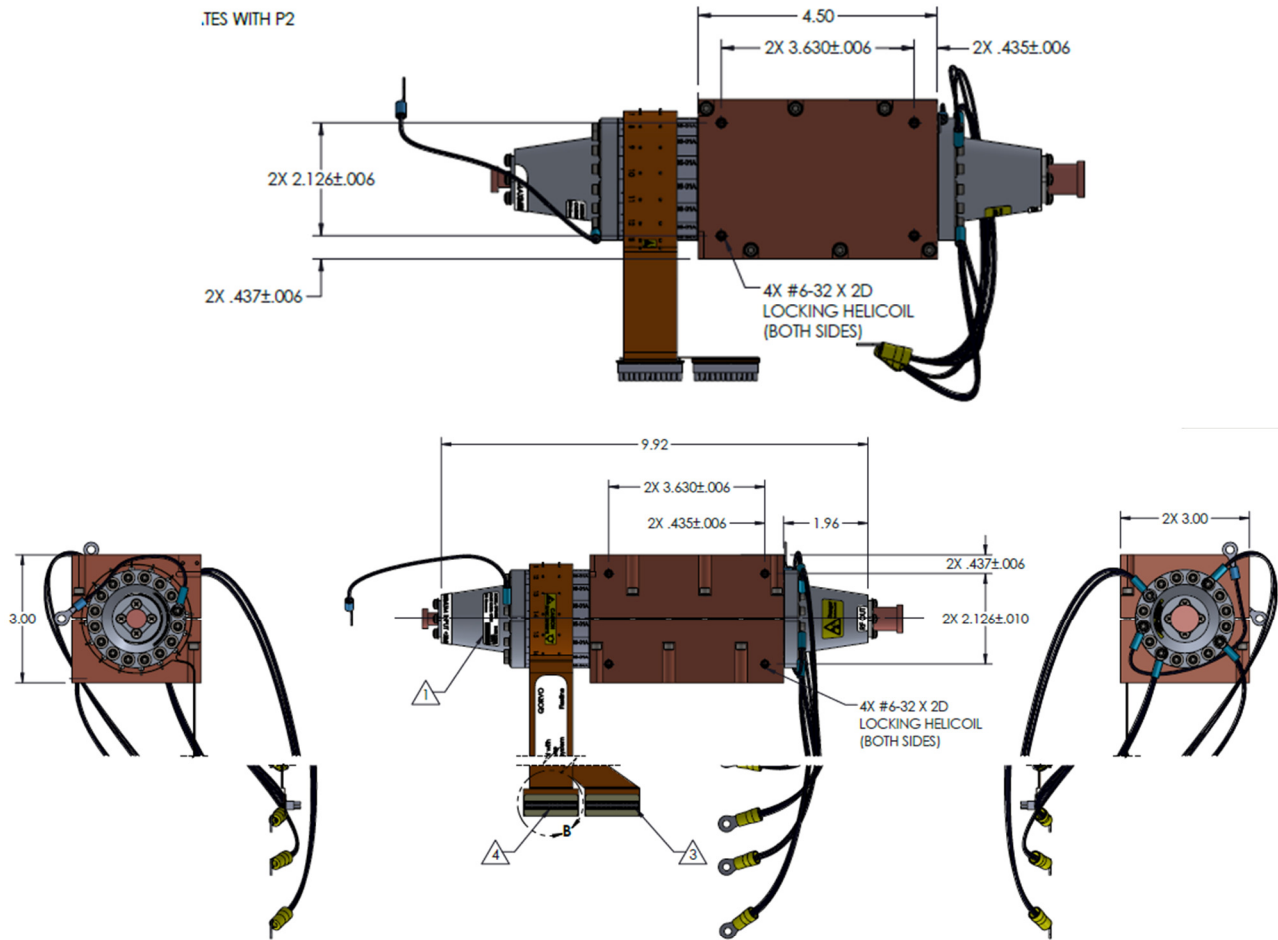

- ⚠ J1 (SAMTEC IPS1 CONN): MATES WITH P1  
PIN OUT MATCHES PLUG.
- ⚠ J2 (SAMTEC IPS1 CONN): MATES WITH P2  
PIN OUT MATCHES PLUG.

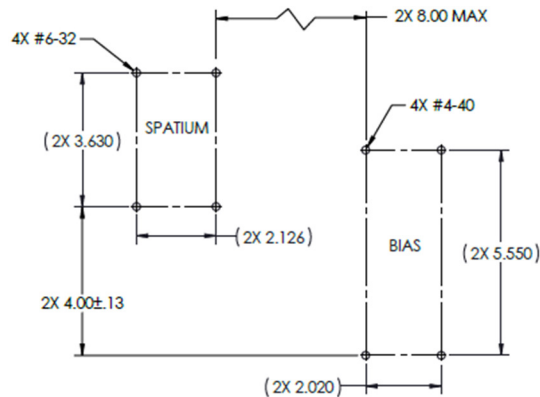

**SPATIUM AND BIAS  
RECOMMENDED MOUNTING HOLE LOCATIONS**

Units in INCHES

**Package Marking and Dimensions (continued)**

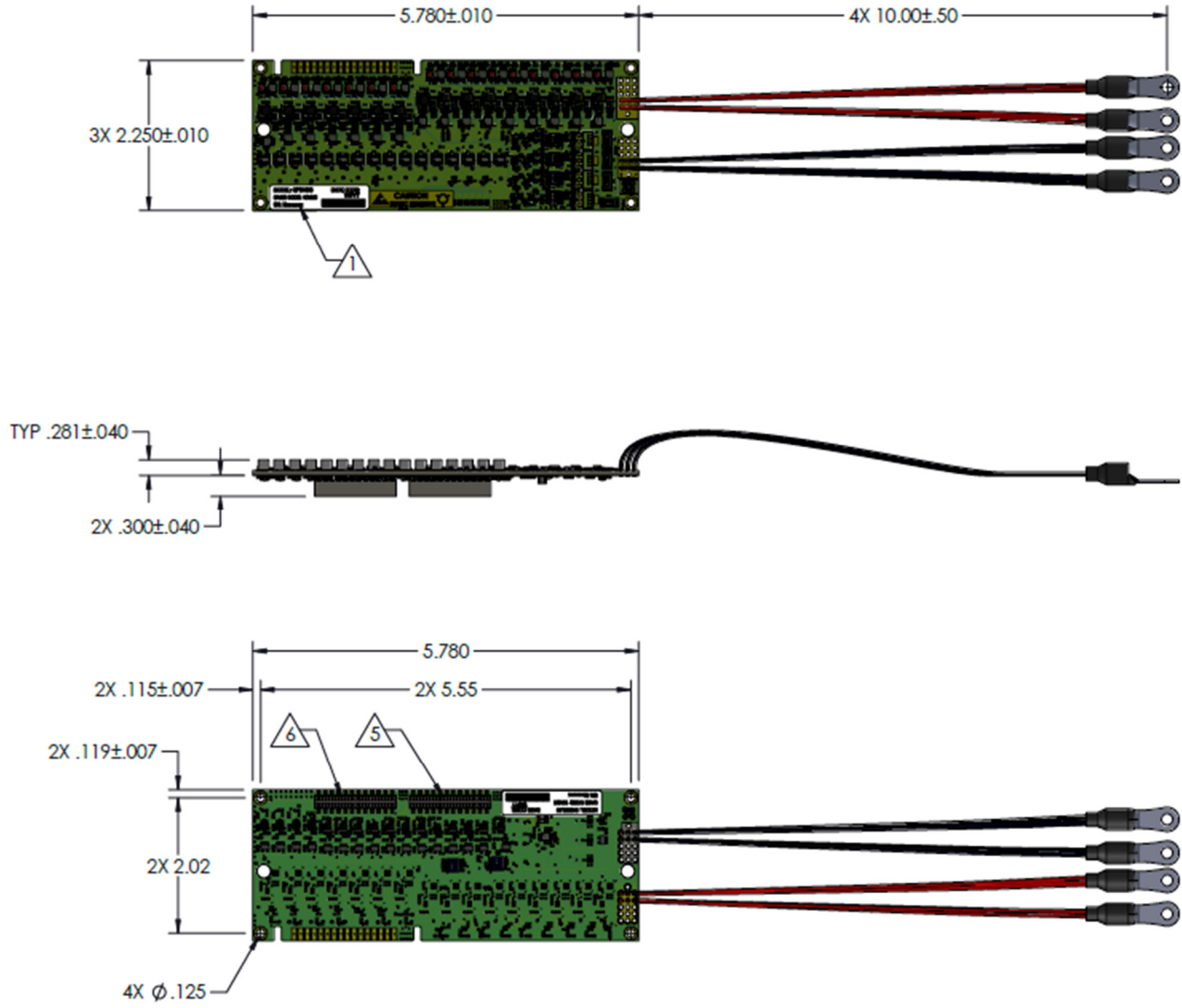

Bias Circuit Card Detail

Units in INCHES



## Handling Precautions

---



Caution!  
ESD-Sensitive Device

## Contact Information

---

For the latest specifications, additional product information, worldwide sales and distribution locations:

**Tel: 1-844-890-8163**

**Web: [www.qorvo.com](http://www.qorvo.com)**

**Email: [customer.support@qorvo.com](mailto:customer.support@qorvo.com)**

For technical questions and application information: **Email: [spatium-info.engineering@qorvo.com](mailto:spatium-info.engineering@qorvo.com)**

## Important Notice

---

The information contained herein is believed to be reliable. Qorvo makes no warranties regarding the information contained herein. Qorvo assumes no responsibility or liability whatsoever for any of the information contained herein. Qorvo assumes no responsibility or liability whatsoever for the use of the information contained herein. The information contained herein is provided "AS IS, WHERE IS" and with all faults, and the entire risk associated with such information is entirely with the user. All information contained herein is subject to change without notice. Customers should obtain and verify the latest relevant information before placing orders for Qorvo products. The information contained herein or any use of such information does not grant, explicitly or implicitly, to any party any patent rights, licenses, or any other intellectual property rights, whether with regard to such information itself or anything described by such information.

Qorvo products are not warranted or authorized for use as critical components in medical, life-saving, or life-sustaining applications, or other applications where a failure would reasonably be expected to cause severe personal injury or death.

Copyright 2017 © Qorvo, Inc. | Qorvo is a registered trademark of Qorvo, Inc.