

### Product Overview

Qorvo’s QPM1021 is a packaged, high power amplifier fabricated on Qorvo’s production 0.15 um GaN on SiC process. The QPM1021 operates from 10–12 GHz and provides 100 W (50 dBm) of saturated output power with 20 dB of large signal gain and greater than 32 % power-added efficiency.

The QPM1021 is packaged in a 10-lead 19.05 x 19.05 mm bolt-down package, with a pure copper base for superior thermal management. Both RF ports are internally DC blocked and matched to 50 ohms allowing for simple system integration.

The QPM1021 is ideally suited for both commercial and military radar systems, satellite communications systems, and data links.

RoHS compliant.

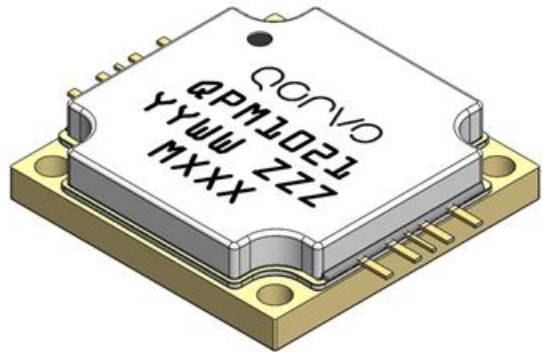

### Key Features

- Frequency Range: 10 – 12 GHz
- $P_{SAT}$ : > 50 dBm ( $P_{IN}$  = 28 dBm)
- PAE: > 32% ( $P_{IN}$  = 28 dBm)
- Large Signal Gain: > 20 dB ( $P_{IN}$  = 28 dBm)
- Small Signal Gain: > 26 dB
- Bias:  $V_D$  = 28 V,  $I_{DQ}$  = 2.0 A
- Package Dimensions: 19.05 x 19.05 x 4.52 mm
- Performance Under Pulsed Operation

*Performance is typical across frequency. Please reference electrical specification table and data plots for more details.*

### Functional Block Diagram

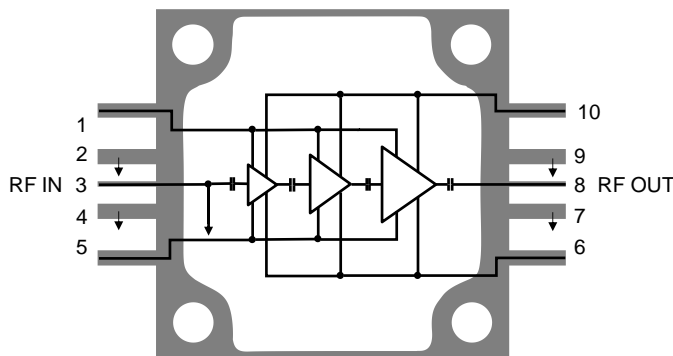

Top View

### Applications

- Radar
- Electronic Warfare

### Ordering Information

Part No.	Description
QPM1021	10–12 GHz 100 Watt GaN Power Amplifier (20 pcs.)
QPM1021S2	QPM1021 Samples (2 pcs.)
QPM1021EVB	QPM1021 Evaluation Board

## Absolute Maximum Ratings

Parameter	Rating
Drain Voltage ( $V_D$ )	29.5 V
Gate Voltage Range ( $V_G$ )	-5 to 0 V
Drain Current ( $I_D$ )	18.2 A
Gate Current ( $I_G$ )	See plot pg. 11
Power Dissipation ( $P_{DISS}$ ), 85 °C, Pulsed; PW = 150 $\mu$ s, DC = 20%	435 Watts
Input Power ( $P_{IN}$ ), 50 $\Omega$ , 85 °C, $V_D = 28$ V, Pulsed; PW = 150 $\mu$ s, DC = 20%	32 dBm
Input Power ( $P_{IN}$ ), 85 °C, VSWR 3:1, $V_D = 28$ V, Pulsed; PW = 150 $\mu$ s, DC = 20%	38 dBm
Mounting Temperature	Refer to Assembly Notes, page 15
Storage Temperature	-55 to 150 °C

Exceeding any one or a combination of the Absolute Maximum Rating conditions may cause permanent damage to the device. Extended application of Absolute Maximum Rating conditions to the device may reduce device reliability.

## Electrical Specifications

Parameter	Conditions <sup>(1)</sup>	Min	Typ	Max	Units
Frequency Range		10		12	GHz
Output Power	$P_{IN} = 28$ dBm, Pulsed	10.0 GHz 49.5 11.2 GHz 48.0 12.0 GHz 48.0	51.3 50.3 50.4		dBm
Power Added Efficiency	$P_{IN} = 28$ dBm, Pulsed	10.0 GHz 22.0 11.2 GHz 20.8 12.0 GHz 19.2	32.9 29.4 26.2		%
$P_{OUT}$ Temperature Coefficient	Temp: 25 °C to 85 °C, $P_{IN} = 28$ dBm)		-0.012		dB/°C
Small Signal Gain		10.0 GHz 11.2 GHz 12.0 GHz	26.6 22.8 20.2		dB
Input Return Loss			13		dB
Output Return Loss			11		dB
Small Sig. Gain Temp. Coefficient	Temp: -40°C to 85 °C		-0.110		dB/°C
Recommended Operating Voltage		24	28	28	V

Notes:

Test conditions unless otherwise noted: T = 25 °C,  $V_D = 28$  V,  $I_{DQ} = 2.0$  A, PW = 150  $\mu$ s, Duty Cycle = 20%

## Recommended Operating Conditions

Parameter	Min	Typ	Max	Units
Drain Voltage ( $V_D$ )		28		V
Drain Current ( $I_{DQ}$ )		2.0		A
Operating Temperature Range	-40	25	85	°C

Electrical specifications are measured at specified test conditions. Specifications are not guaranteed over all recommended operating conditions.

## Performance Plots – Large Signal

Test conditions unless otherwise noted:  $T = 25\text{ }^{\circ}\text{C}$ ,  $V_D = 28\text{ V}$ ,  $I_{DQ} = 2.0\text{ A}$ ,  $P_{IN} = 28\text{ dBm}$ ,  $PW = 150\text{ }\mu\text{s}$ , Duty Cycle = 20%

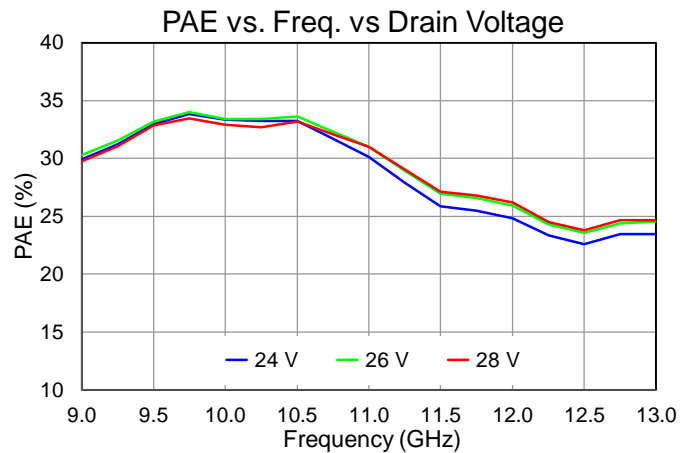
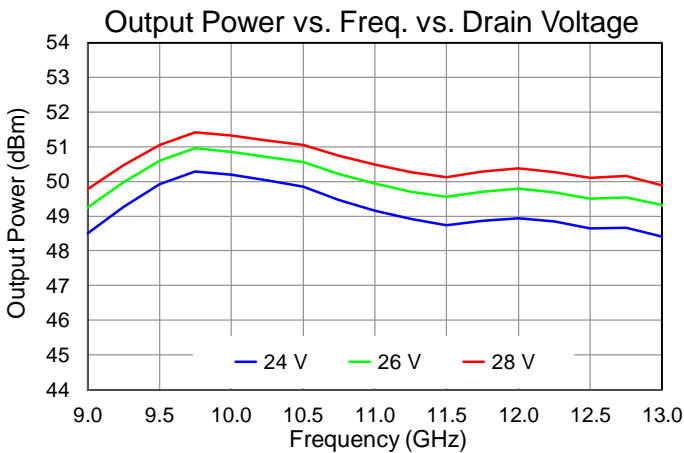
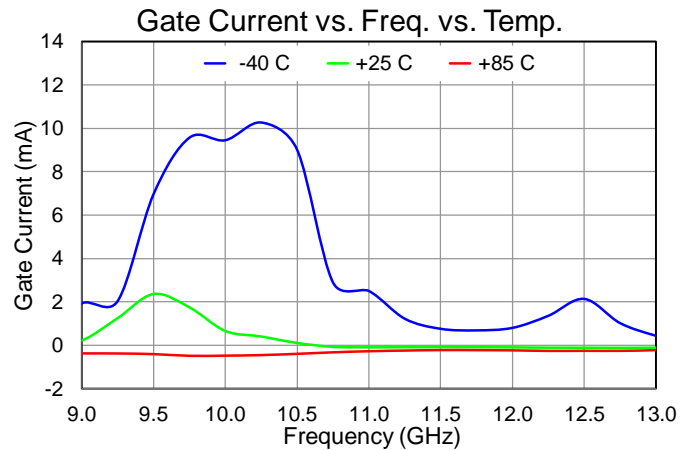
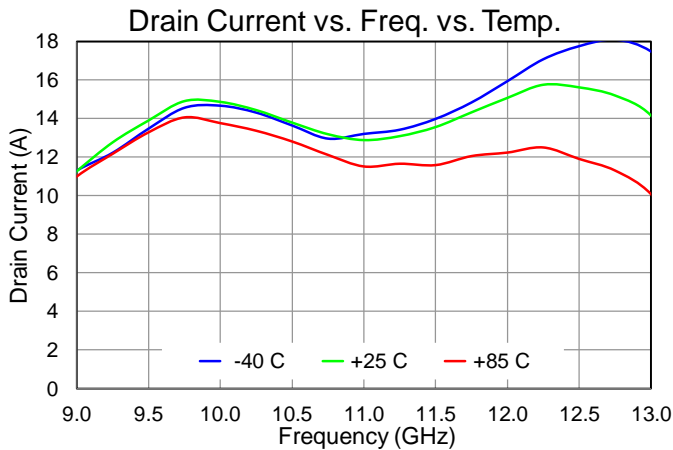
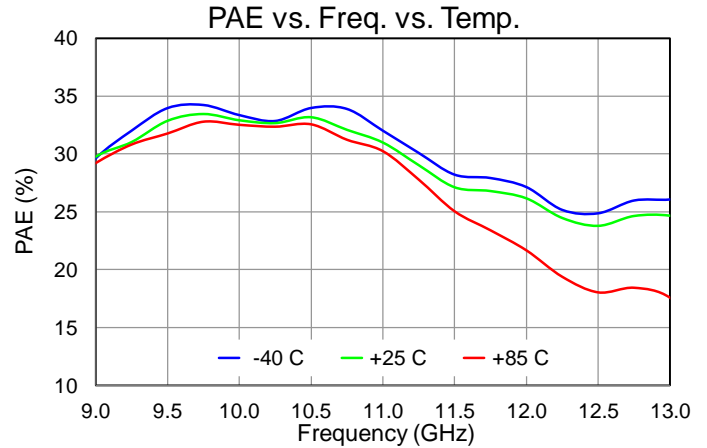
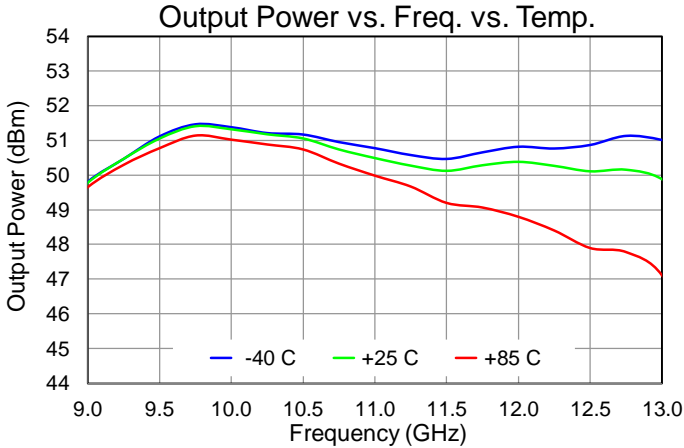

## Performance Plots – Large Signal

Test conditions unless otherwise noted:  $T = 25\text{ }^{\circ}\text{C}$ ,  $V_D = 28\text{ V}$ ,  $I_{DQ} = 2.0\text{ A}$ ,  $P_{IN} = 28\text{ dBm}$ ,  $PW = 150\text{ }\mu\text{s}$ , Duty Cycle = 20%

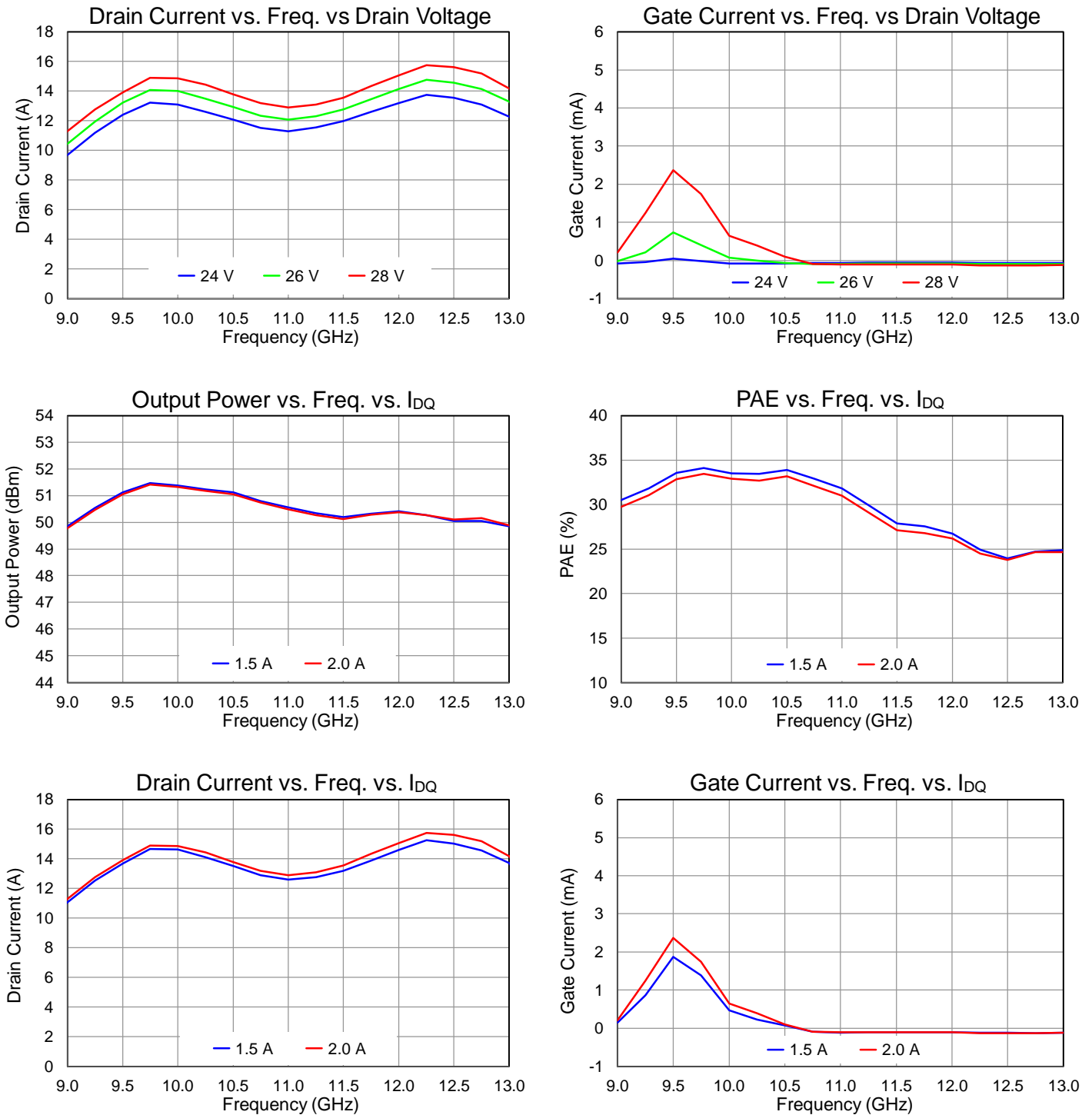

## Performance Plots – Large Signal

Test conditions unless otherwise noted:  $T = 25\text{ }^{\circ}\text{C}$ ,  $V_D = 28\text{ V}$ ,  $I_{DQ} = 2.0\text{ A}$ ,  $P_{IN} = 28\text{ dBm}$ ,  $PW = 150\text{ }\mu\text{s}$ , Duty Cycle = 20%

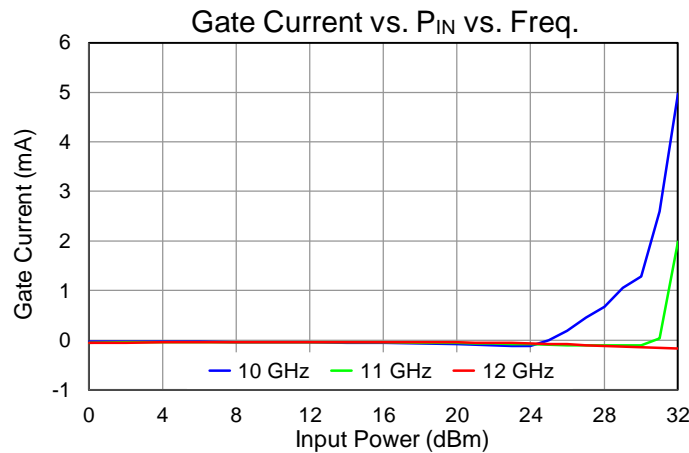
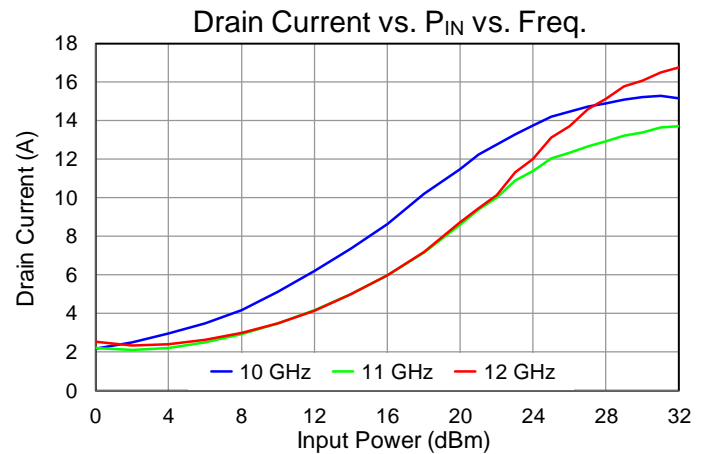
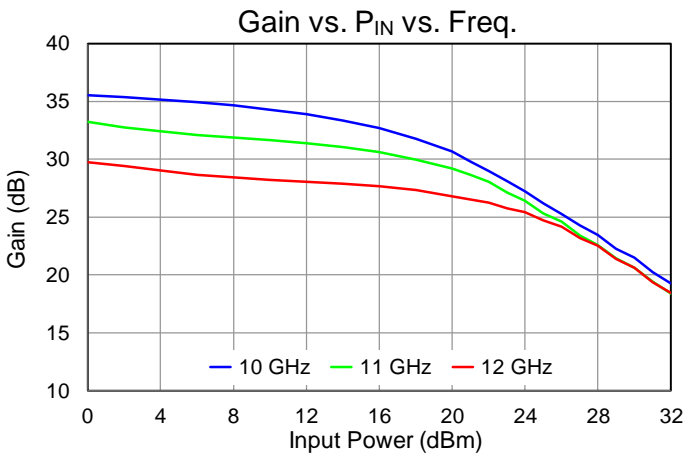
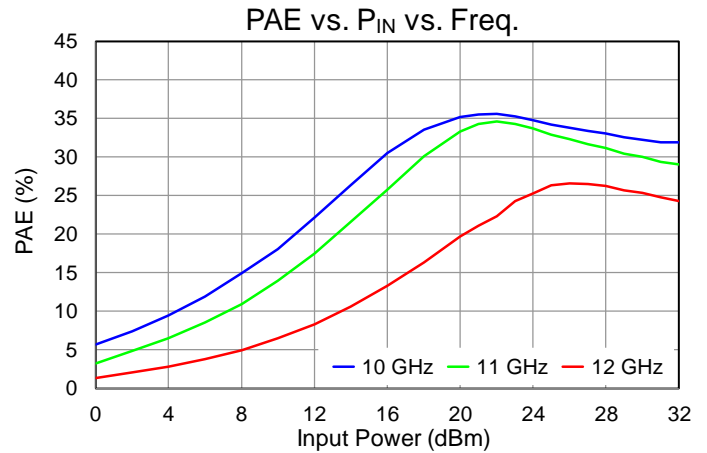
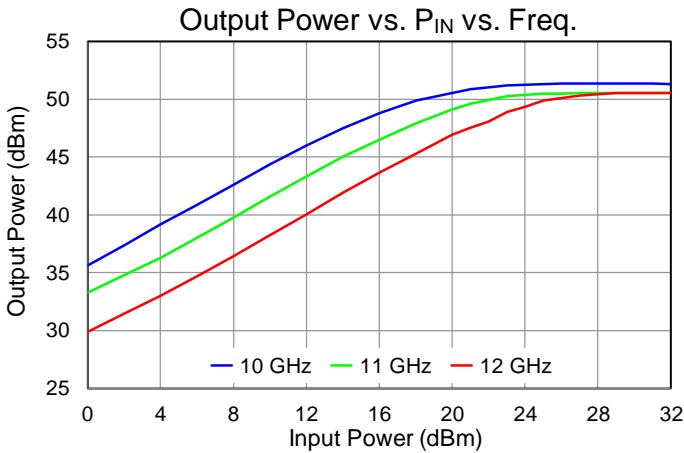

## Performance Plots – Large Signal

Test conditions unless otherwise noted:  $T = 25\text{ }^{\circ}\text{C}$ ,  $V_D = 28\text{ V}$ ,  $I_{DQ} = 2.0\text{ A}$ ,  $\text{Freq} = 11\text{ GHz}$ ,  $\text{PW} = 150\text{ }\mu\text{s}$ ,  $\text{Duty Cycle} = 20\%$

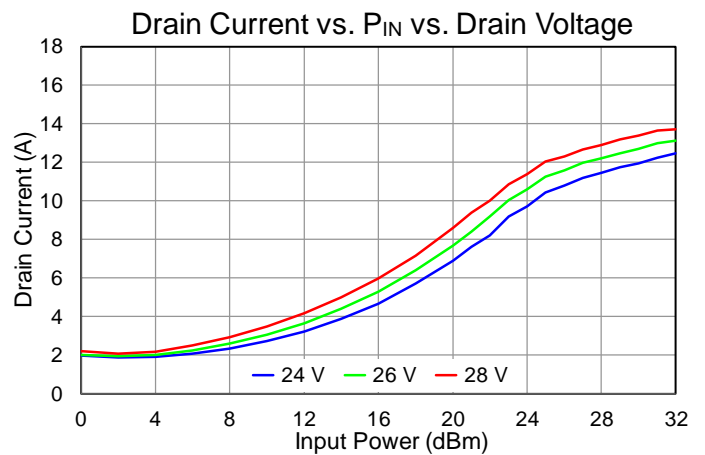
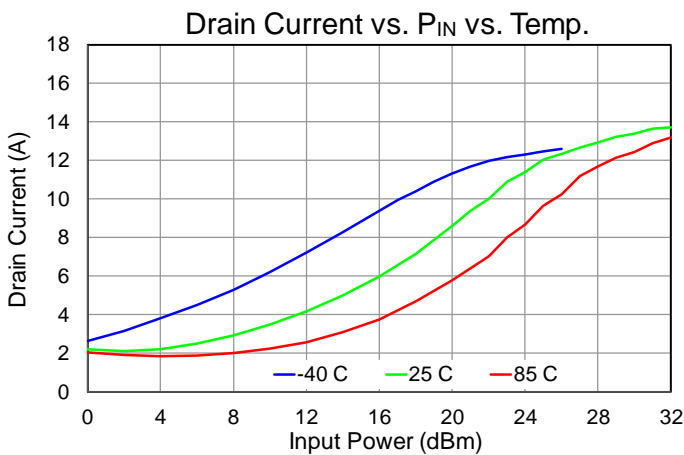
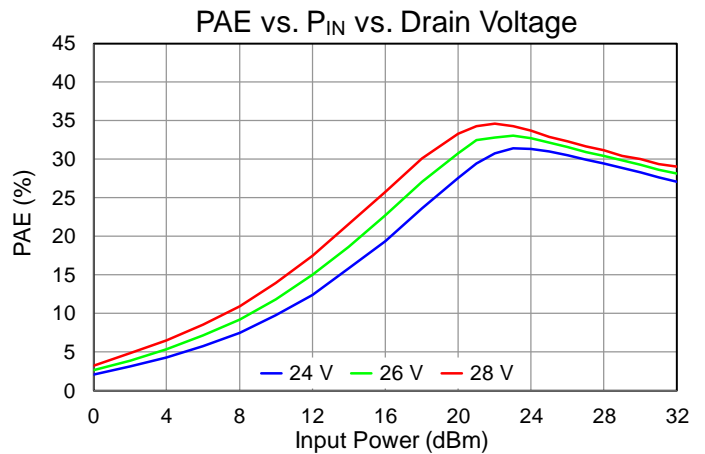
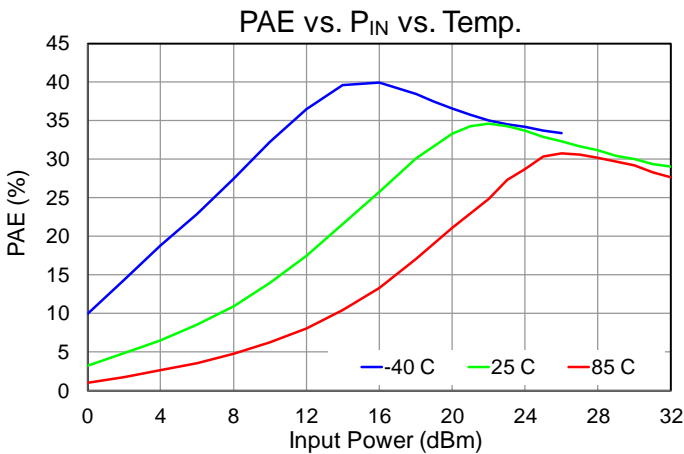
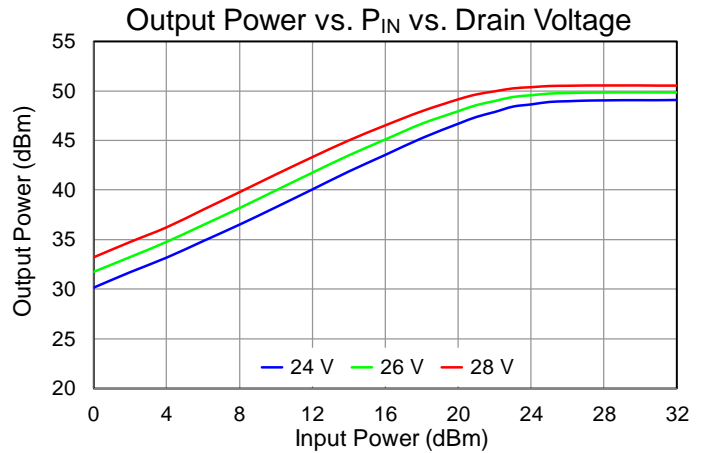
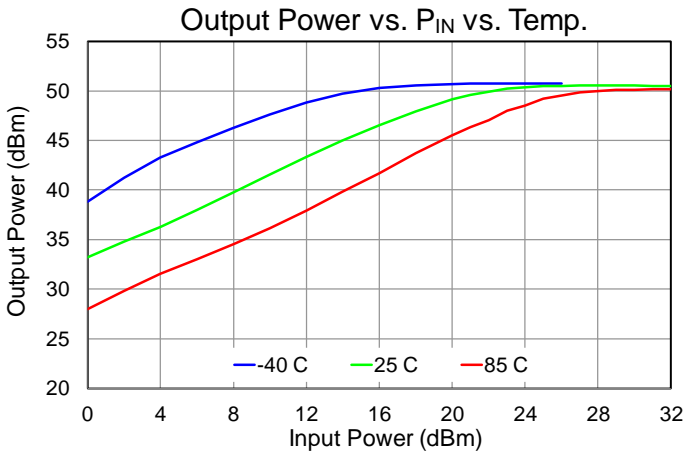

## Performance Plots – Large Signal

Test conditions unless otherwise noted:  $T = 25\text{ }^{\circ}\text{C}$ ,  $V_D = 28\text{ V}$ ,  $I_{DQ} = 2.0\text{ A}$ ,  $\text{Freq} = 11\text{ GHz}$ ,  $\text{PW} = 150\text{ }\mu\text{s}$ ,  $\text{Duty Cycle} = 20\%$

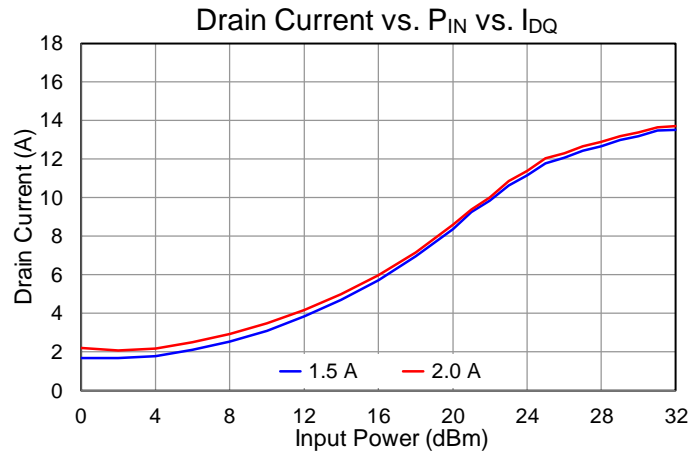
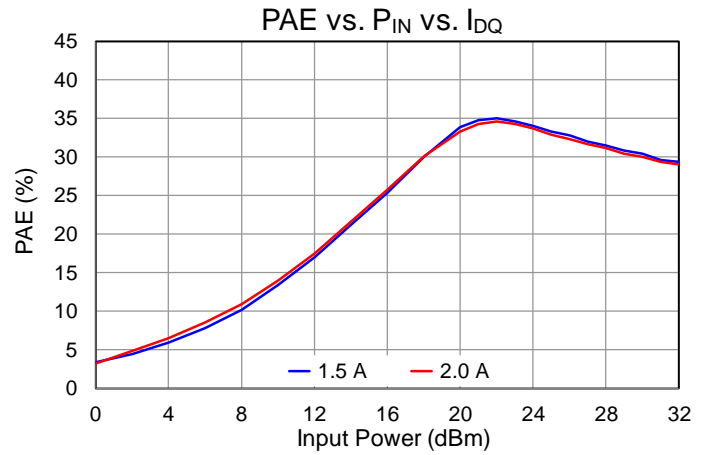
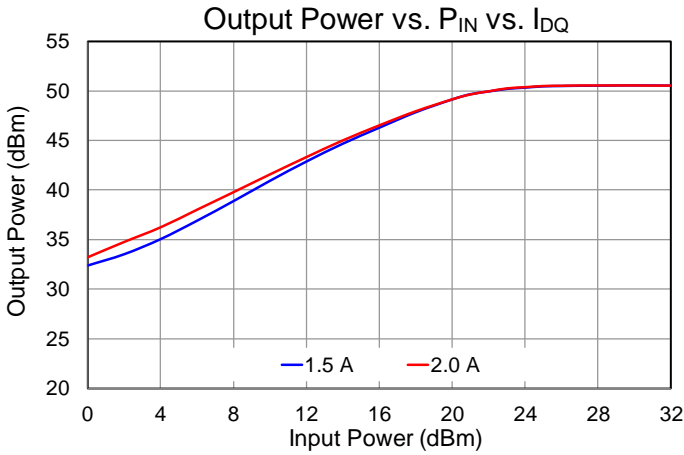

Performance Plots – Harmonics

Test conditions unless otherwise noted: T = 25 °C, V<sub>D</sub> = 28 V, I<sub>DQ</sub> = 2.0 A, PW = 150 us, Duty Cycle = 20%

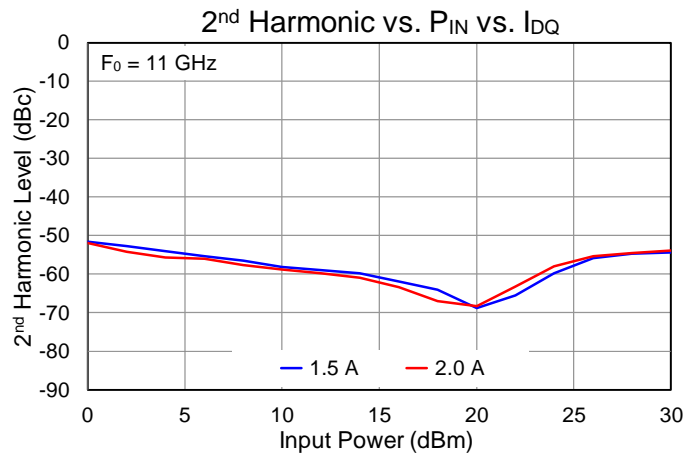
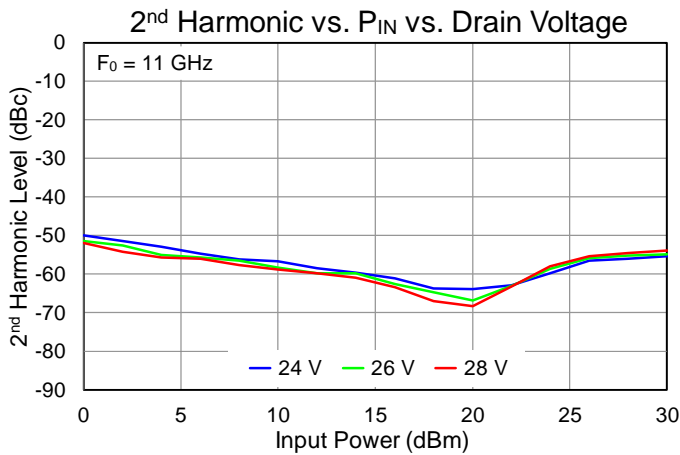
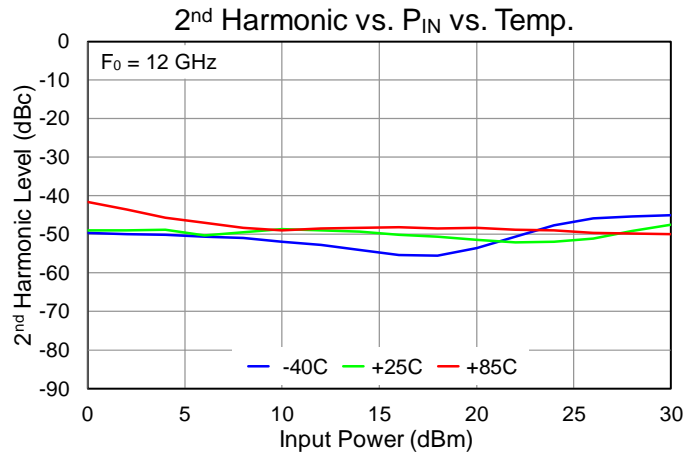
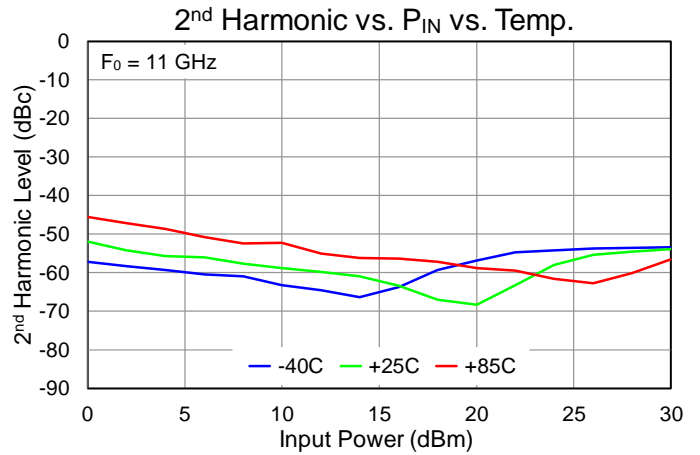
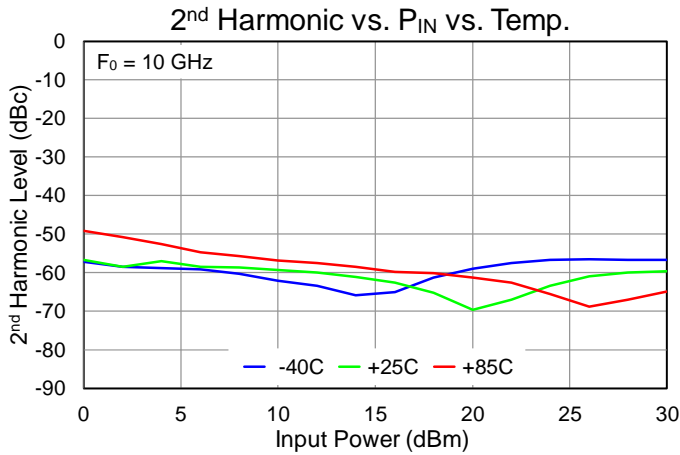



**Performance Plots – Small Signal**

Test conditions unless otherwise noted: T = 25 °C, V<sub>D</sub> = 28 V, I<sub>BQ</sub> = 2.0 A

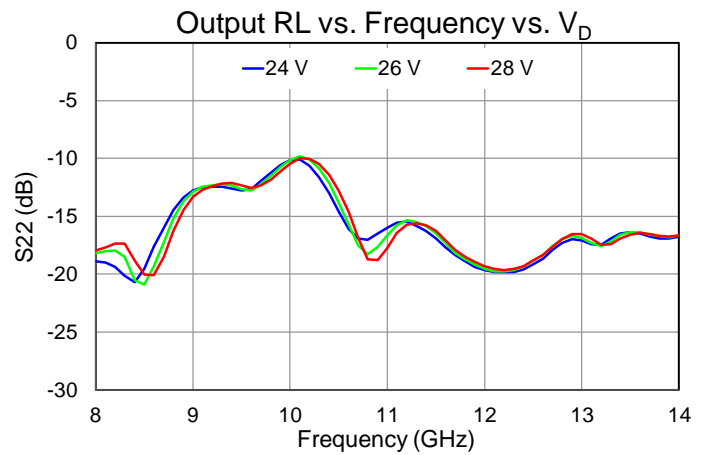
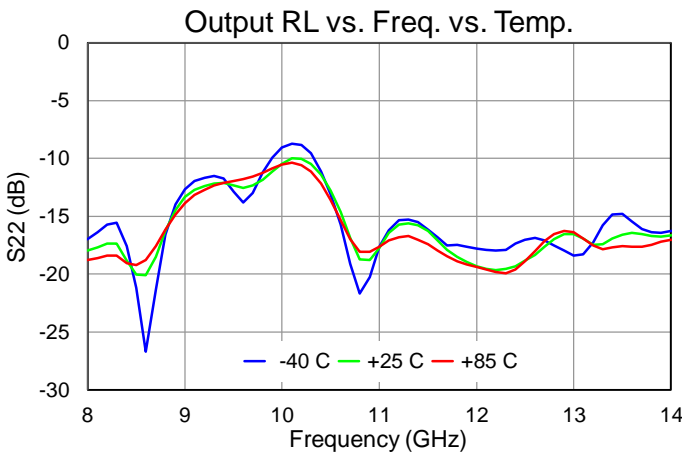
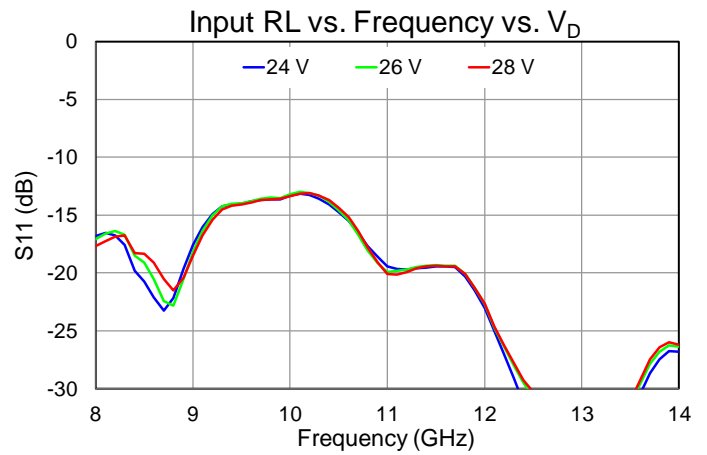
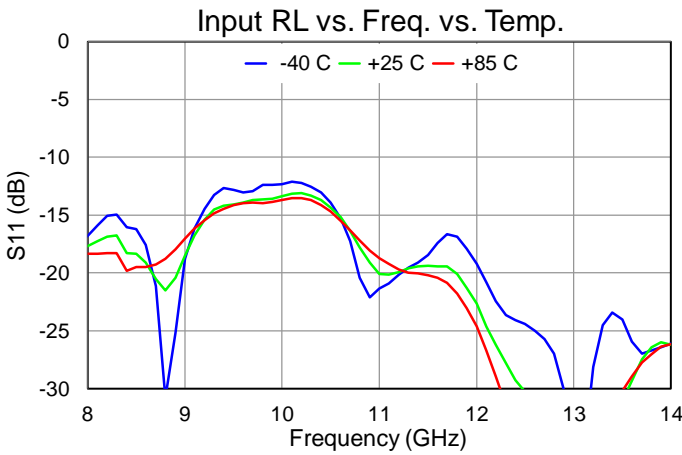
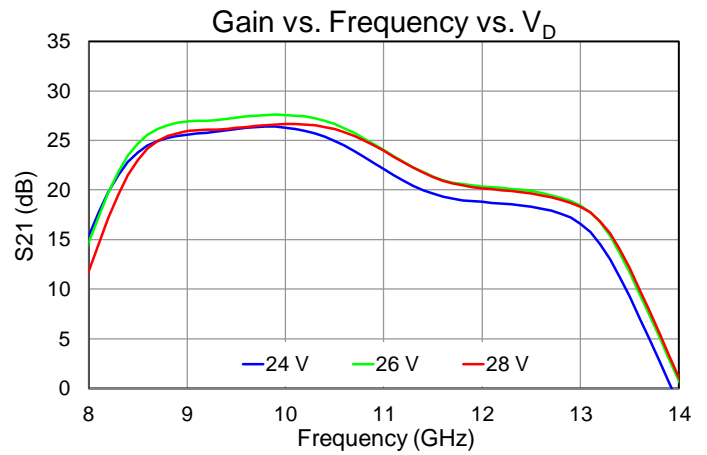
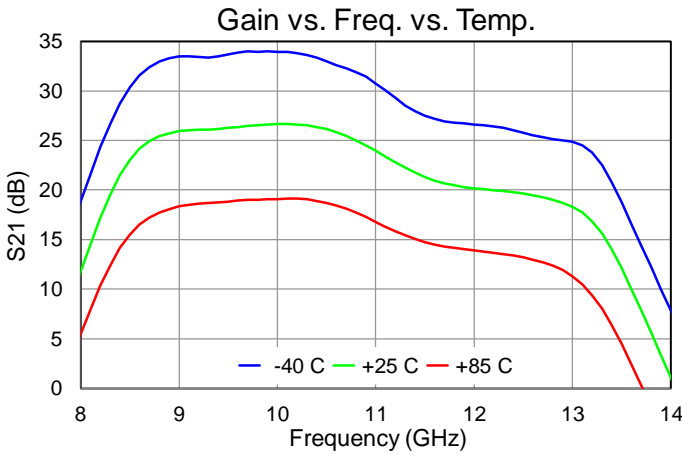

Performance Plots – Small Signal

Test conditions unless otherwise noted: T = 25 °C, V<sub>D</sub> = 28 V, I<sub>DQ</sub> = 2.0 A

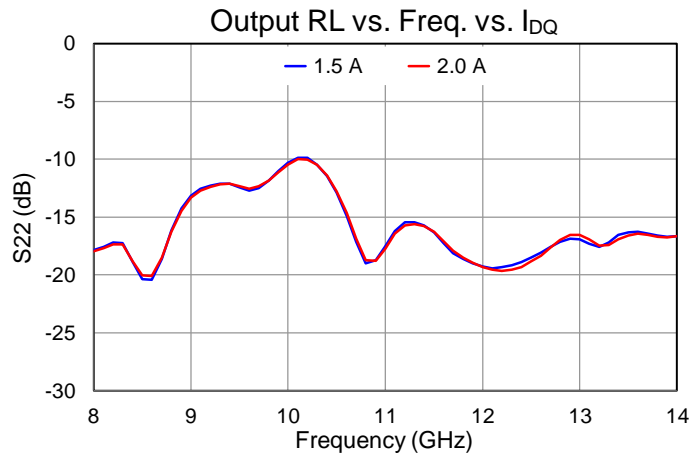
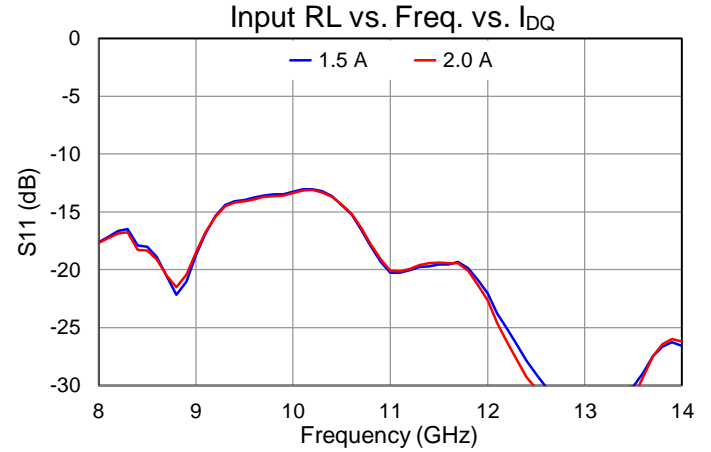
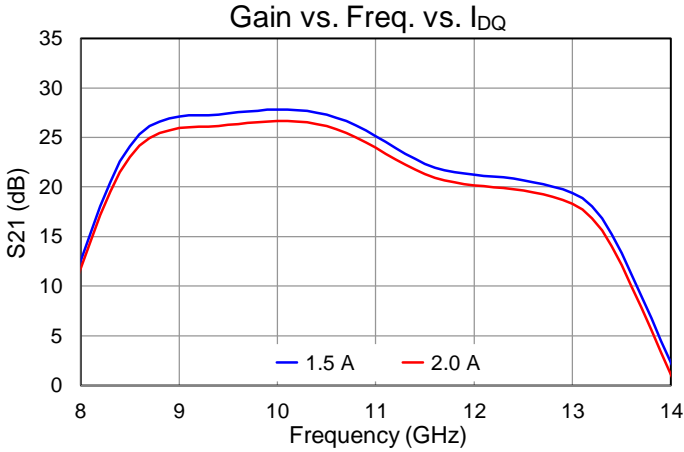

## Thermal and Reliability Information

Parameter	Test Conditions	Value	Units
Thermal Resistance ( $\theta_{JC}$ ) <sup>(1)</sup>	$T_{BASE} = 85^{\circ}\text{C}$ , $V_D = +28\text{ V}$ , $I_{DQ} = 2.0\text{ A}$ , $P_{DISS} = 56\text{ W}$	0.200	$^{\circ}\text{C}/\text{W}$
Channel Temperature, $T_{CH}$ (No RF)		96.1	$^{\circ}\text{C}$
Thermal Resistance ( $\theta_{JC}$ ) <sup>(1)</sup>	$T_{BASE} = 85^{\circ}\text{C}$ , $V_D = +28\text{ V}$ , Freq = 12 GHz, $P_{IN} = 28\text{ dBm}$ , $I_{DQ} = 2.0\text{ A}$ , $I_{D\_Drive} = 12.3\text{ A}$ , $P_{OUT} = 48.8\text{ dBm}$ , $P_{DISS} = 271.3\text{ W}$	0.258	$^{\circ}\text{C}/\text{W}$
Channel Temperature, $T_{CH}$ (Under RF)		154.9	$^{\circ}\text{C}$
Thermal Resistance ( $\theta_{JC}$ ) <sup>(1)</sup>	$T_{BASE} = 85^{\circ}\text{C}$ , $V_D = +28\text{ V}$ , Freq = 12 GHz, $P_{IN} = 32\text{ dBm}$ , $I_{DQ} = 2.0\text{ A}$ , $I_{D\_Drive} = 15.6\text{ A}$ , $P_{OUT} = 50.1\text{ dBm}$ , $P_{DISS} = 333.2\text{ W}$	0.264	$^{\circ}\text{C}/\text{W}$
Channel Temperature, $T_{CH}$ (Under RF)		172.9	$^{\circ}\text{C}$

**Notes:**

1. Thermal resistance measured to back of package ( $T = 85^{\circ}\text{C}$ ).
2. Refer to the following document: [GaN Device Channel Temperature, Thermal Resistance, and Reliability Estimates](#)

## Gate Current and Dissipated Power

Test conditions unless otherwise noted:  $T = 85^{\circ}\text{C}$ ,  $I_{DQ} = 2.0\text{ A}$ ,  $P_{IN} = 28\text{ dBm}$ ,  $PW = 150\text{ us}$ , Duty Cycle = 20%

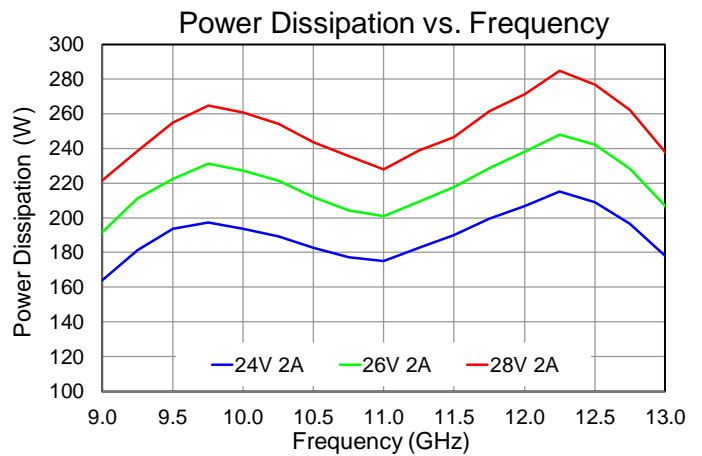
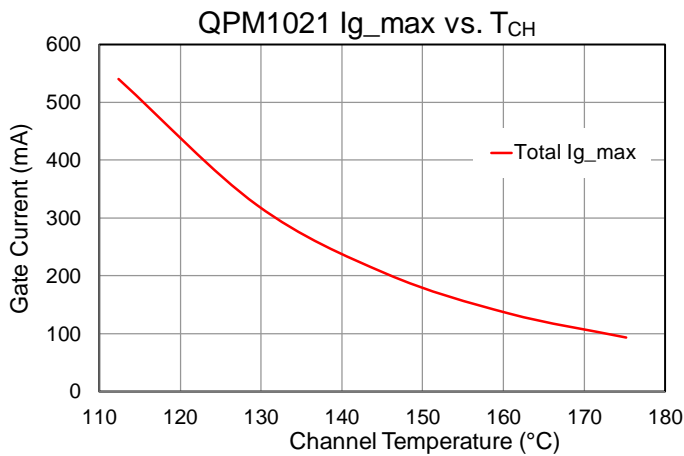

Applications Information

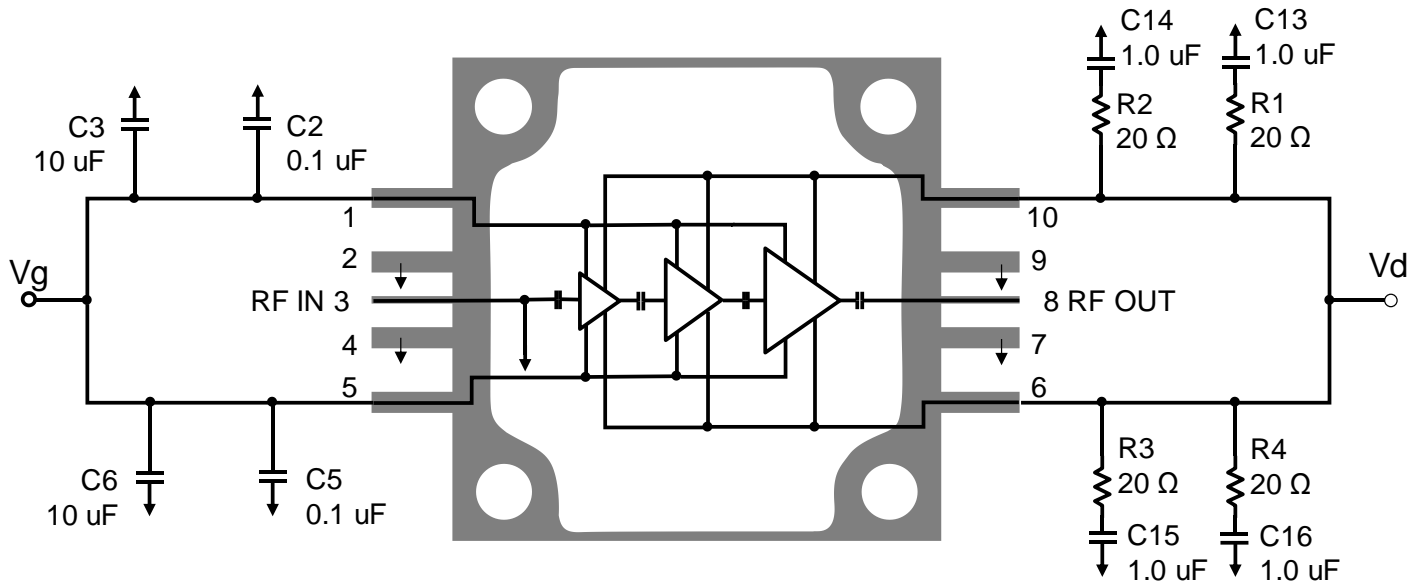

Notes:

1.  $V_G$  &  $V_D$  need to be biased from both sides.

Bias-Up Procedure

1. Set  $I_D$  limit to 17 A (peak),  $I_G$  limit to 60 mA
2. Set  $V_G$  to -5.0 V
3. Set  $V_D$  +28 V
4. Adjust  $V_G$  more positive until  $I_{DQ} = 2.0$  A, peak
5. Apply RF signal

Bias-Down Procedure

1. Turn off RF signal
2. Reduce  $V_G$  to -5.0 V. Ensure  $I_{DQ} \sim 0$ mA
4. Set  $V_D$  to 0 V
5. Turn off  $V_D$  supply
6. Turn off  $V_G$  supply

Evaluation Board (EVB) Layout Assembly

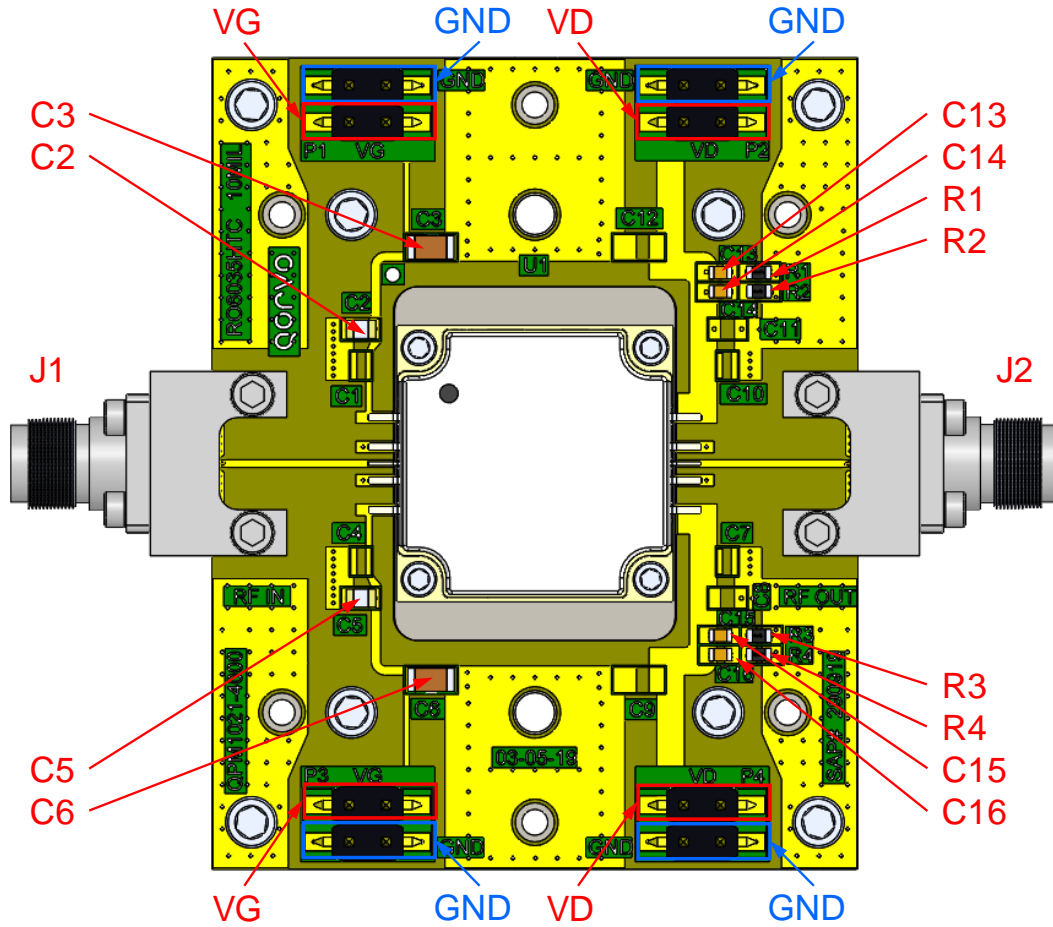

Bill of Materials

Reference Des.	Value	Description	Manuf.	Part Number
C3, C6	10 uF	CAP, CER, 10 uF, 50 V, 20%, X5R, 1206	Various	
C2, C5	0.1 uF	CAP, 0.1uF, 10%, 50V, X7R, 0805	Various	
C13, C14, C15, C16		CAP, 1uF, 10%, 50V, X7R, 0603	Various	
R1, R2, R3, R4	20 Ohm	RES 0603 20Ohms 200mW 1% -55 to +155C	Various	
J1, J2	2.92 mm	Female End Launch Connector	Southwest Microwave	1092-02A-5
PCB	-----	Rogers 6035HTC, 10 mil dielectric, 0.5 oz. copper (gold plated)	Rogers Corp.	

## Mechanical Information and Bond Pad Description

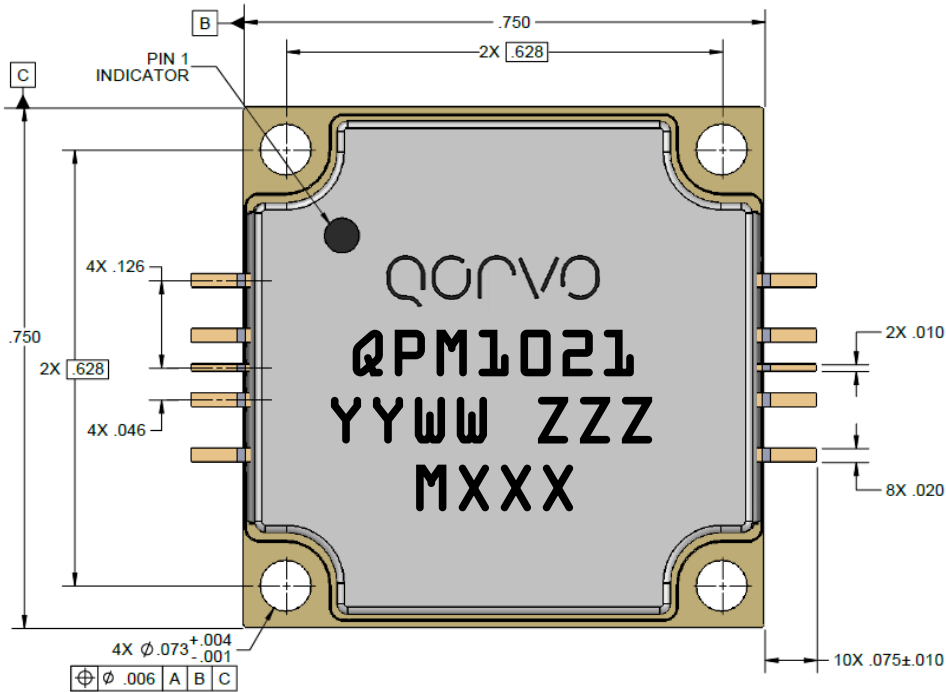

**NOTES:**

1. **MATERIALS**  
 PACKAGE BASE: COPPER  
 LEADS: ALLOY 194  
 LID: PLASTIC  
 FINISH: GOLD
2. **PART IS EPOXY SEALED**
3. **UNITS: INCHES**
4. **TOLERANCES (UNLESS NOTED):**  
 .XX = ± .01  
 .XXX = ± .005
5. **MARKINGS**  
 PART NUMBER: QPM1021  
 WORK YEAR: YY  
 WORK WEEK: WW  
 SERIAL NUMBER: ZZZ  
 BATCH ID: MXXX



## Package Lead Description

Pad No.	Symbol	Description
1, 5	V <sub>G</sub>	Gate voltage. Bias network is required; see Application Circuit on page 12. Gate must be biased from both sides.
2, 4, 7, 9	Ground	Must be grounded to PCB
3	RF Input	RF Input; matched to 50 Ω, DC blocked, DC grounded
6, 10	V <sub>D</sub>	Drain voltage. Bias network is required; see Application Circuit on page 12.
8	RF Output	RF Output; matched to 50 Ω, DC blocked

## Assembly Notes

---

1. Carefully clean the PC board, base plate, and package leads with alcohol. Allow it to dry fully.
2. To improve the thermal and RF performance, Qorvo recommends attaching a heat sink to the bottom of the package and apply either a thermal compound (Arctic Silver 5 recommended) or a .004 inch (maximum thickness) Indium shim between the heat sink and the package. Refer to the applications note [Application of Arctic Silver 5 Thermal Compound and Indium Shims for Qorvo CP-style Packaged Components](#) for more information.
3. The component leads should be manually soldered. Apply a low residue solder alloy meeting J-STD-001 (ROLO, ROL1 or equivalent) with a liquidus temperature below 220 °C to each pin of the QPM1021. The use of low residue/no-clean flux (ROLO, ROL1) is recommended. The package lead temperature should not exceed 260 deg C. Each solder connection should be completed within 2 to 5 seconds. Adding flux during hand soldering of the component leads with localized spot cleaning is acceptable. Soldering irons meeting the requirements of J-STD-001, Appendix A are acceptable.
4. The leads should be soldered in a staggered or star pattern from side to side, and never solder two adjacent leads. This allows the heat to dissipate on each lead, and not cause the adjacent leads to become de-soldered and damaged or displaced.



5. The packaged part should not be subjected to conventional SMT automated solder reflow processes.
6. (The following is for information only. There are many variables in a second level assembly that Qorvo does not control, so Qorvo does not recommend an absolute torque value.) Use screws to attach the component to the heat sink. A suggested final torque value is 16 in-oz. for a 0-80 screw. Start with screws finger tight, then torque to 8 in-oz., then torque to final value. Use the following tightening pattern:

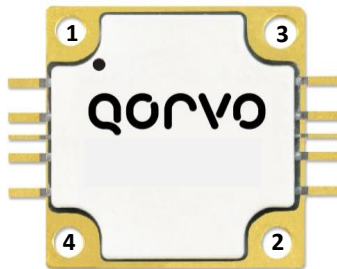

## Handling Precautions

Parameter	Rating	Standard
ESD – Human Body Model (HBM)	1C	ESDA / JEDEC JS-001-2012
ESD – Charged Device Model (CDM)	C3	JEDEC JESD22-C101F
MSL – Moisture Sensitivity Level	NA	



Caution!  
ESD-Sensitive Device

## Solderability

The component leads should be manually soldered, and the package cannot be subjected to conventional reflow processes. The use of no-clean solder to avoid washing after soldering is recommended.

## RoHS Compliance

This part is compliant with 2011/65/EU RoHS directive (Restrictions on the Use of Certain Hazardous Substances in Electrical and Electronic Equipment) as amended by Directive 2015/863/EU.

This product also has the following attributes:

- Halogen Free (Chlorine, Bromine)
- Antimony Free
- TBBP-A (C<sub>15</sub>H<sub>12</sub>Br<sub>4</sub>O<sub>2</sub>) Free
- PFOS Free
- SVHC Free

## Contact Information

For the latest specifications, additional product information, worldwide sales and distribution locations:

**Web:** [www.qorvo.com](http://www.qorvo.com)

**Tel:** 1-844-890-8163

**Email:** [customer.support@qorvo.com](mailto:customer.support@qorvo.com)

## Important Notice

The information contained herein is believed to be reliable; however, Qorvo makes no warranties regarding the information contained herein and assumes no responsibility or liability whatsoever for the use of the information contained herein. All information contained herein is subject to change without notice. Customers should obtain and verify the latest relevant information before placing orders for Qorvo products. The information contained herein or any use of such information does not grant, explicitly or implicitly, to any party any patent rights, licenses, or any other intellectual property rights, whether with regard to such information itself or anything described by such information. **THIS INFORMATION DOES NOT CONSTITUTE A WARRANTY WITH RESPECT TO THE PRODUCTS DESCRIBED HEREIN, AND QORVO HEREBY DISCLAIMS ANY AND ALL WARRANTIES WITH RESPECT TO SUCH PRODUCTS WHETHER EXPRESS OR IMPLIED BY LAW, COURSE OF DEALING, COURSE OF PERFORMANCE, USAGE OF TRADE OR OTHERWISE, INCLUDING THE IMPLIED WARRANTIES OF MERCHANTABILITY AND FITNESS FOR A PARTICULAR PURPOSE.**

Without limiting the generality of the foregoing, Qorvo products are not warranted or authorized for use as critical components in medical, life-saving, or life-sustaining applications, or other applications where a failure would reasonably be expected to cause severe personal injury or death.

Copyright 2023 © Qorvo, Inc. | Qorvo is a registered trademark of Qorvo, Inc.