

DO NOT
SCALE FROM
THIS PRINT

No OF POSITIONS
-026, -052, -078
(PER ROW)

SOLDER TAIL LEAD STYLE
-01: 1.57[.062] BOARD
*-02: 2.36[.093] BOARD

(* = NOT TOOLED)

OPTION
-K: POLYIMIDE FILM
(NOT AVAILABLE FOR
-026 & -078)
(USE K-500-300,
SEE FIG. 2, SHT 4)
-TR: TAPE & REEL
(SEE NOTE 10)

GUIDE POSTS REQUIREMENT
-GP (SEE NOTE 9)

RIGHT ANGLE
-RA

PLATING SPECIFICATION

-S: SELECTIVE, 30Au / 50Ni MIN ON
CONTACT, MATTE TIN ON TAIL
(USE C-288-XX-S & IM-T-1G36-XX-S)
-L: LIGHT SELECTIVE, 30Au / 50Ni MIN ON
CONTACT, MATTE TIN ON TAIL
(USE C-288-XX-L & IM-T-1G36-XX-L)

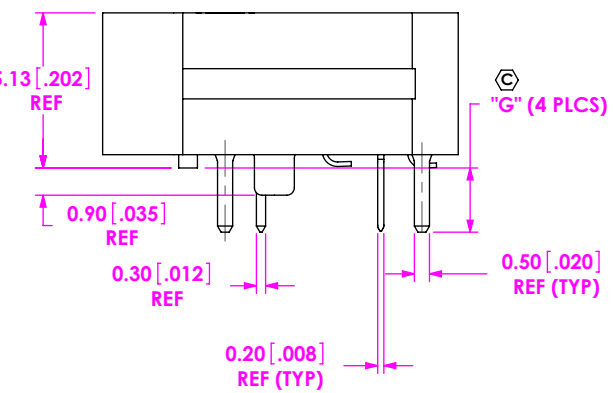
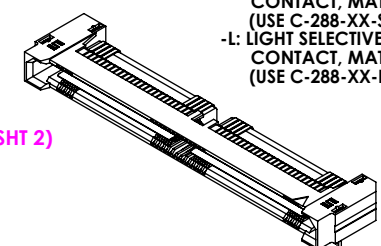
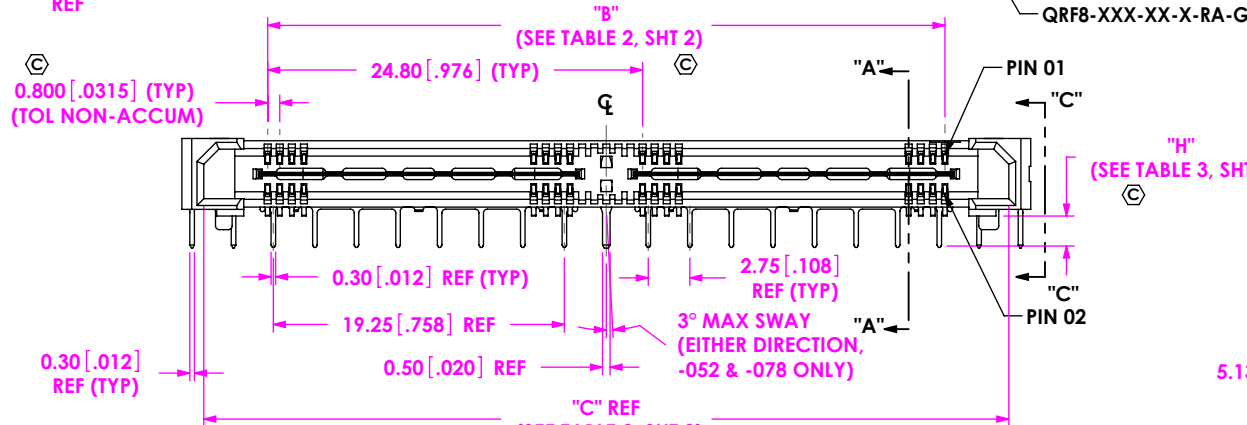
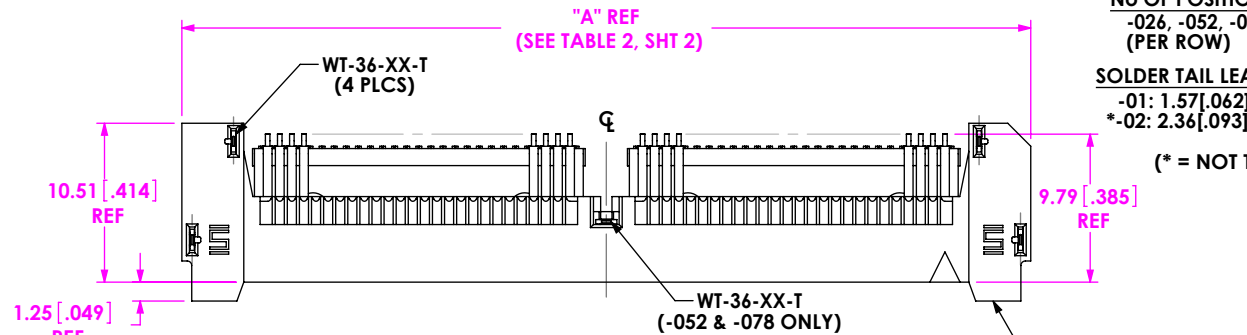

TABLE 1

LEAD STYLE	"OVER MOLDED GROUND PLANE"	"WELD TAB"
-01	IM-T-1G36-01-X	WT-36-01-T
*-02	IM-T-1G36-02-X	WT-36-02-T

(* = NOT TOOLED)

NOTES:

- ⊕ REPRESENTS A CRITICAL DIMENSION.
- BURR ALLOWANCE: 0.038[.0015] MAX.
- MINIMUM PUSHOUT FORCE: SIGNAL: 2.22N[.5 LB].
GROUND PLANE: 4.45N[1 LB].
- NOTE DELETED.
- MEASURE AT BEND TANGENCY.
- MEASURE ON PINS ONLY, STANDOFFS NOT INCLUDED IN MEASUREMENT.
- POST HEIGHT VARIATION BETWEEN ANY TWO PINS: 0.05[.002] MAXIMUM.
- FIRST ROW TAILS TO BE FLUSH TO .08 ABOVE THE SECOND ROW.
- PARTS WITH THE -GP OPTION MUST MATE TO -GP OPTIONED QRF8 PARTS.
- PARTS TO BE PACKAGED IN TRAYS, UNLESS -TR OPTION IS SPECIFIED.
- 078 POSITION IS NOT AVAILABLE IN TAPE AND REEL.
- CPC'S MUST BE MEASURED BOTH ENDS OF COMB OR CONNECTOR.
- USE INSPECTION FIXTURE # AT-2298-801-01 TO CHECK CRITICALS.

UNLESS OTHERWISE SPECIFIED,
DIMENSIONS ARE IN
MILLIMETERS [INCHES].
TOLERANCES ARE:
DECIMALS ANGLES
X.X: ±0.3 [0.1] 2°
X.XX: ±0.13 [0.05]
X.XXX: ±0.051 [0.020]

PROPRIETARY NOTE
THIS DOCUMENT CONTAINS INFORMATION
CONFIDENTIAL AND PROPRIETARY TO
SAMTEC, INC. AND SHALL NOT BE REPRODUCED
OR TRANSFERRED TO OTHER DOCUMENTS OR
DISCLOSED TO OTHERS OR USED FOR ANY
PURPOSE OTHER THAN THAT WHICH IT WAS
OBTAINED WITHOUT THE EXPRESSED WRITTEN
CONSENT OF SAMTEC, INC.

MATERIAL: DO NOT SCALE DRAWING SHEET SCALE: 2:1
INSULATORS: LCP
CONTACT: PHOS BRONZE
GROUND PLANE: PHOS BRONZE



520 PARK EAST BLVD, NEW ALBANY, IN 47150
PHONE: 812-944-6733 FAX: 812-948-5047
e-Mail info@SAMTEC.com code 55322

DESCRIPTION:
0.8mm Q-RATE RIGHT ANGLE SOCKET ASSEMBLY
DWG. NO.
QRF8-XXX-XX-X-RA-GP-XX
BY: R MUSSER 09/19/2008 SHEET 1 OF 5

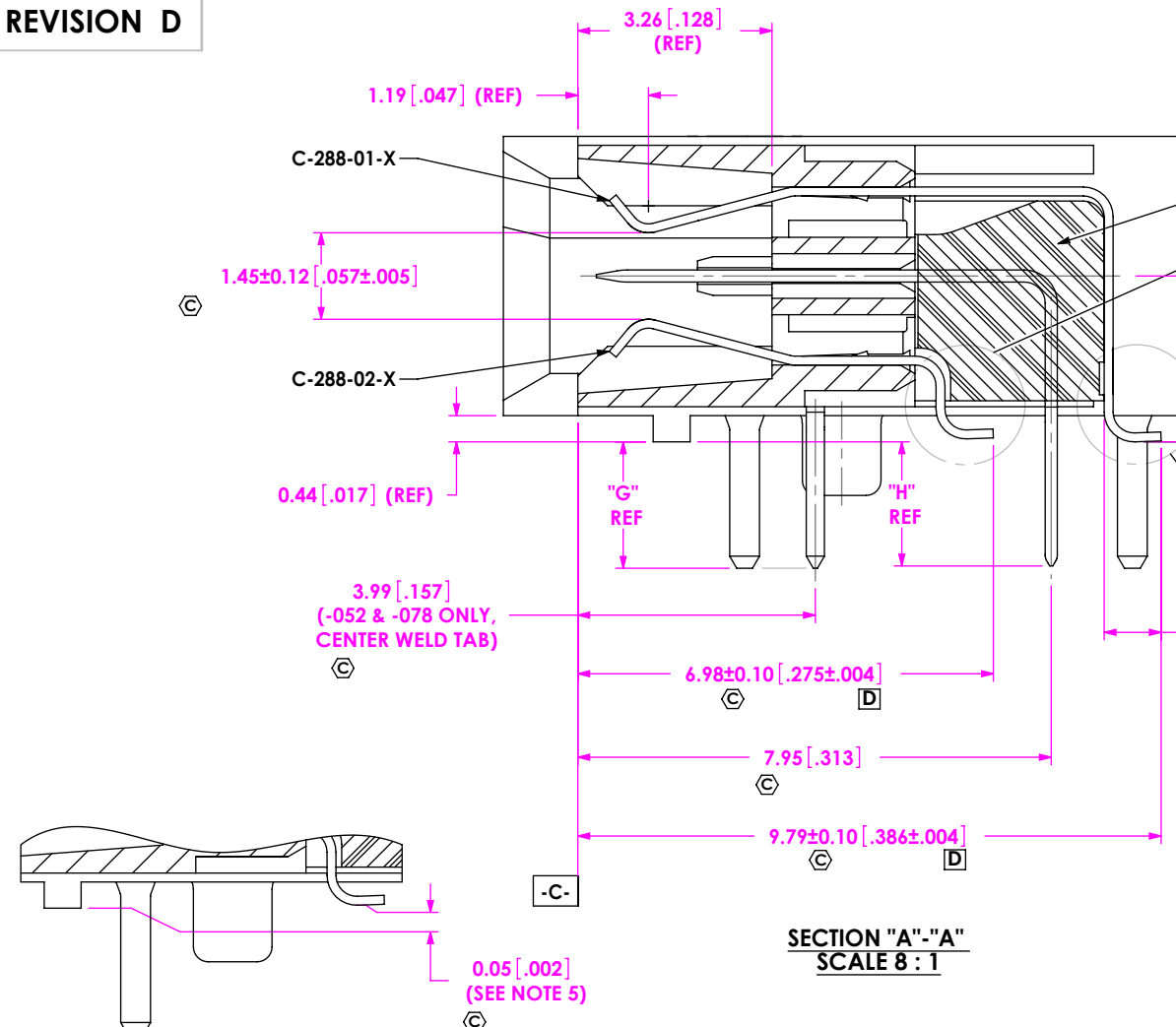

TABLE 4

No OF POSITIONS	BOTTOM ROW STRAIGHTNESS	TOP ROW STRAIGHTNESS	COPLANARITY
-026, -052, -078	0.10 [0.004]	0.10 [0.004]	0.15 [0.006]

TABLE 3

LEAD STYLE	"G"	"H"
-01	1.33 [0.052]	1.29 [0.051]
*-02	2.12 [0.083]	2.08 [0.082]

(* = NOT TOOLED)

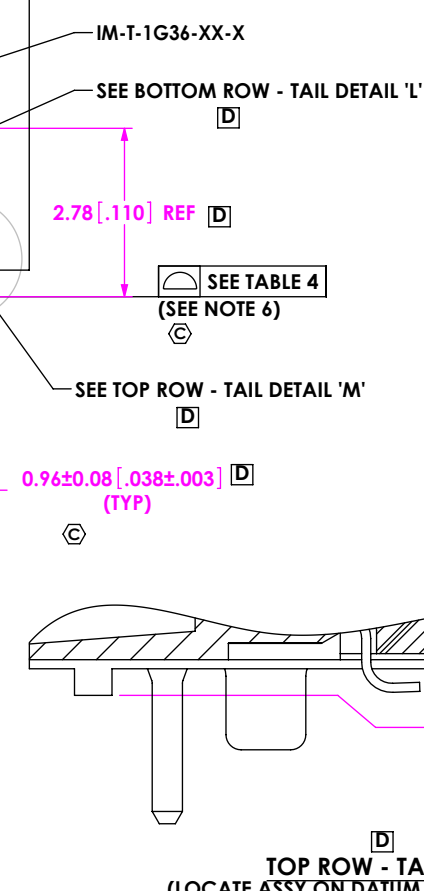

SECTION "A"-"A"
SCALE 8 : 1

TOP ROW - TAIL DETAIL 'M'
(LOCATE ASSY ON DATUM -C- FOR MEASUREMENTS)

BOTTOM ROW - TAIL DETAIL 'L'
(LOCATE ASSY ON DATUM -C- FOR MEASUREMENTS)

TABLE 2

No OF POSITIONS	"A"	"B"	"C"	"D"	"E"	"F"
-026	31.35 [1.234]	20.00 [0.787]	28.45 [1.120]	25.80 [1.016]	24.52 [0.965]	30.00 [1.181]
-052	56.15 [2.211]	44.80 [1.764]	53.25 [2.096]	50.60 [1.992]	49.32 [1.942]	54.80 [2.157]
-078	80.95 [3.187]	69.60 [2.740]	78.05 [3.073]	75.40 [2.969]	74.12 [2.918]	79.60 [3.134]

PROPRIETARY NOTE
THIS DOCUMENT CONTAINS INFORMATION CONFIDENTIAL AND PROPRIETARY TO SAMTEC, INC. AND SHALL NOT BE REPRODUCED OR TRANSFERRED TO OTHER DOCUMENTS OR DISCLOSED TO OTHERS OR USED FOR ANY PURPOSE OTHER THAN THAT WHICH IT WAS OBTAINED WITHOUT THE EXPRESSED WRITTEN CONSENT OF SAMTEC, INC.



520 PARK EAST BLVD, NEW ALBANY, IN 47150
PHONE: 812-944-6733 FAX: 812-948-5047
e-Mail info@SAMTEC.com code 55322

DO NOT SCALE DRAWING

SHEET SCALE: 2:1

DESCRIPTION:
0.8mm Q-RATE RIGHT ANGLE SOCKET ASSEMBLY

DWG. NO.
QRF8-XXX-XX-X-RA-GP-XX

BY: R MUSSER 09/19/2008 SHEET 2 OF 5

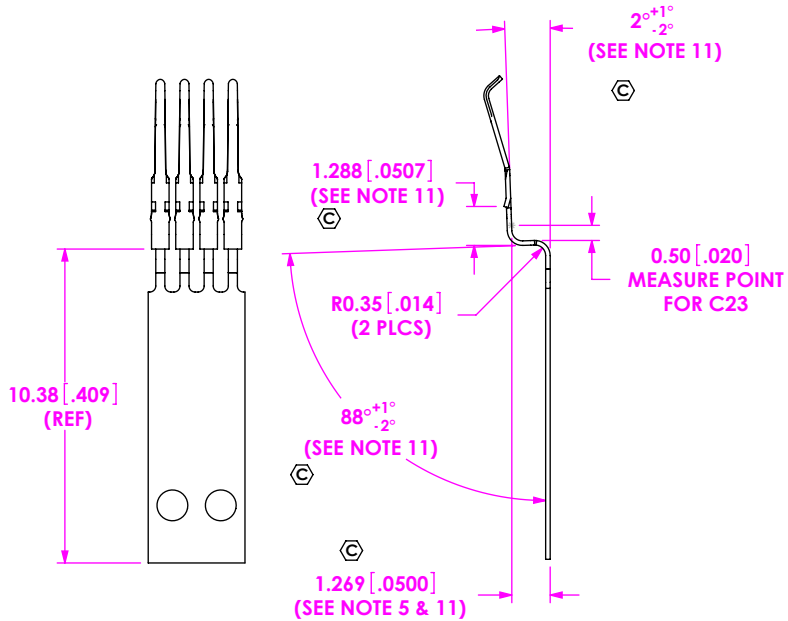

IN PROCESS 1
 [D] (FORM CONTACT C-288-02-X)

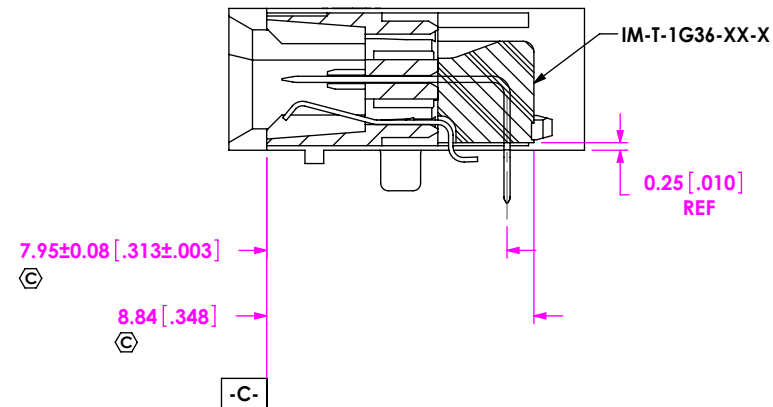

IN PROCESS 4
 (FILL OVER MOLDED GROUND PLANE)
 (IM-T-1G36-XX-X)

IN PROCESS 2
 (FILL BOTTOM ROW)

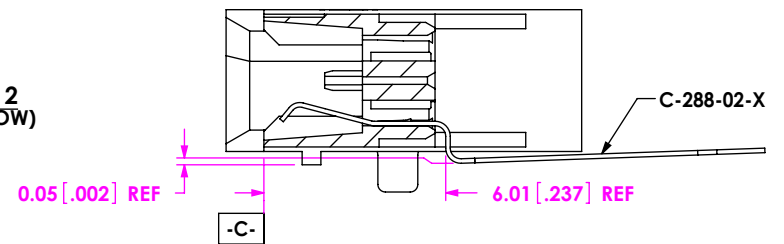

(SEE INSPECTION VIEW 1 FOR ASSEMBLY ORIENTATION AND CPC'S)

IN PROCESS 3
 (CUTOFF OF CARRIER)

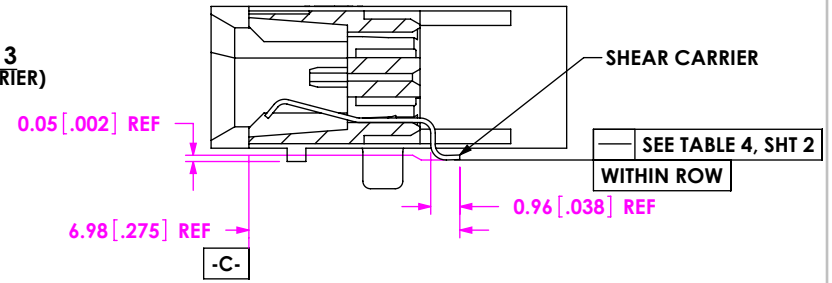

(SEE INSPECTION VIEW 1 FOR ASSEMBLY ORIENTATION AND CPC'S)

INSPECTION VIEW 1
 (SEE NOTE 12)

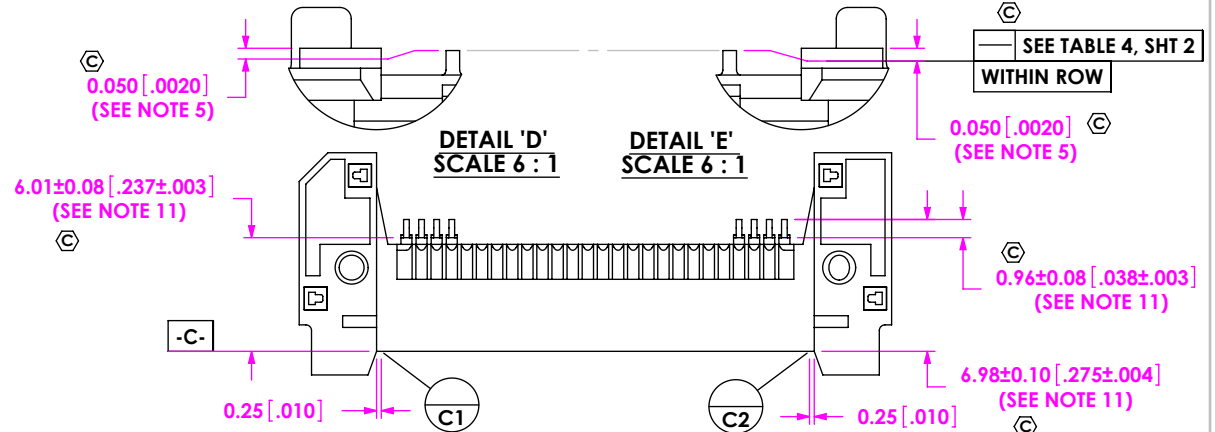
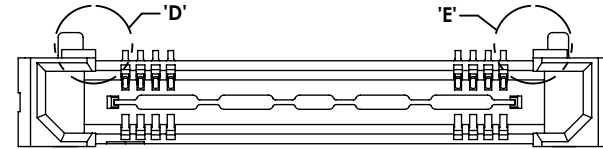

INSPECTION FOR IN PROCESS 2 & 3
 (CARRIER NOT SHOWN FOR IN PROCESS 2 INSPECTIONS)

PROPRIETARY NOTE
 THIS DOCUMENT CONTAINS INFORMATION CONFIDENTIAL AND PROPRIETARY TO SAMTEC, INC. AND SHALL NOT BE REPRODUCED OR TRANSFERRED TO OTHER DOCUMENTS OR DISCLOSED TO OTHERS OR USED FOR ANY PURPOSE OTHER THAN THAT WHICH IT WAS OBTAINED WITHOUT THE EXPRESSED WRITTEN CONSENT OF SAMTEC, INC.

DO NOT SCALE DRAWING

SHEET SCALE: 4:1

samtec

520 PARK EAST BLVD, NEW ALBANY, IN 47150
 PHONE: 812-944-6733 FAX: 812-948-5047
 e-Mail info@SAMTEC.com code 55322

DESCRIPTION:
 0.8mm Q-RATE RIGHT ANGLE SOCKET ASSEMBLY

DWG. NO.
QRF8-XXX-XX-X-RA-GP-XX

BY: R MUSSER 09/19/2008 SHEET 3 OF 5

REVISION D

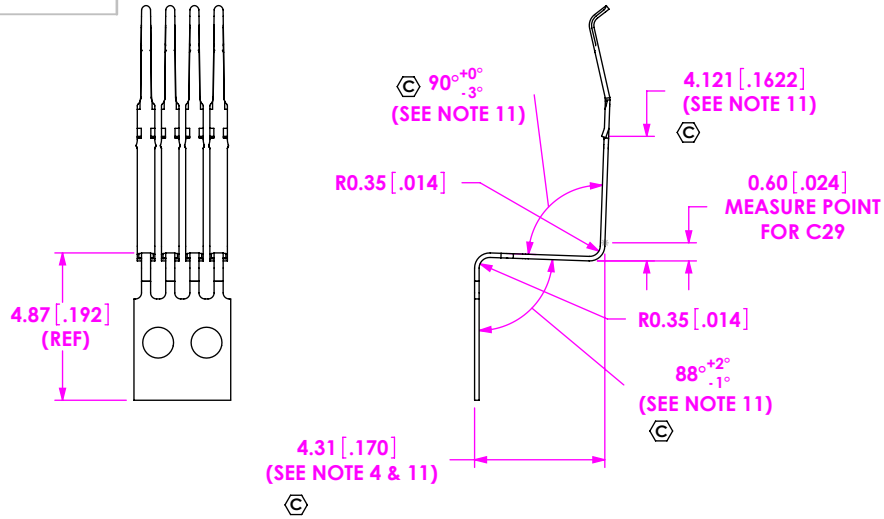

IN PROCESS 5
D (FORM CONTACT C-288-01-X)

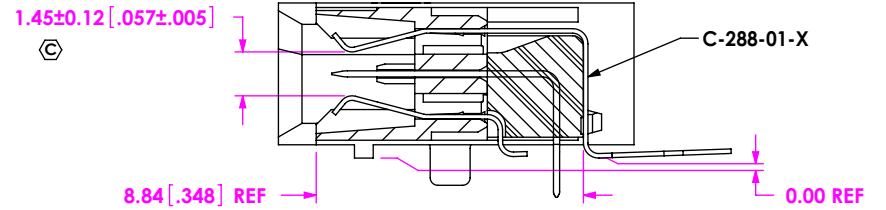

IN PROCESS 6
(FILL TOP ROW)
 (SEE INSPECTION VIEW 2 FOR ASSEMBLY ORIENTATION AND CPC'S)

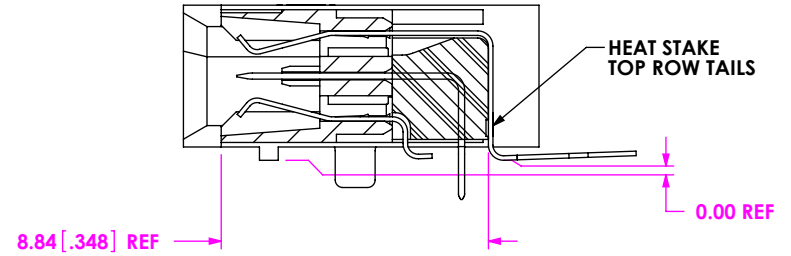

IN PROCESS 7
(HEAT STAKE TOP ROW CONTACTS)
 (SEE INSPECTION VIEW 2 FOR ASSEMBLY ORIENTATION AND CPC'S)

INSPECTION VIEW 2
 (SEE NOTE 12)

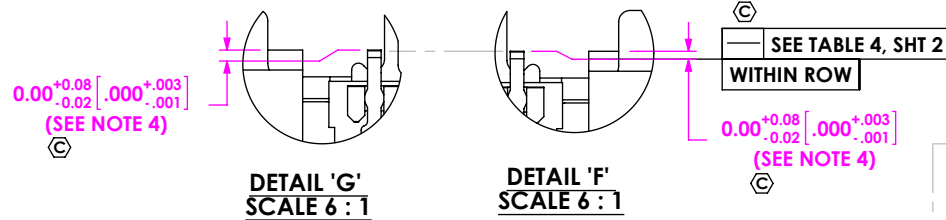
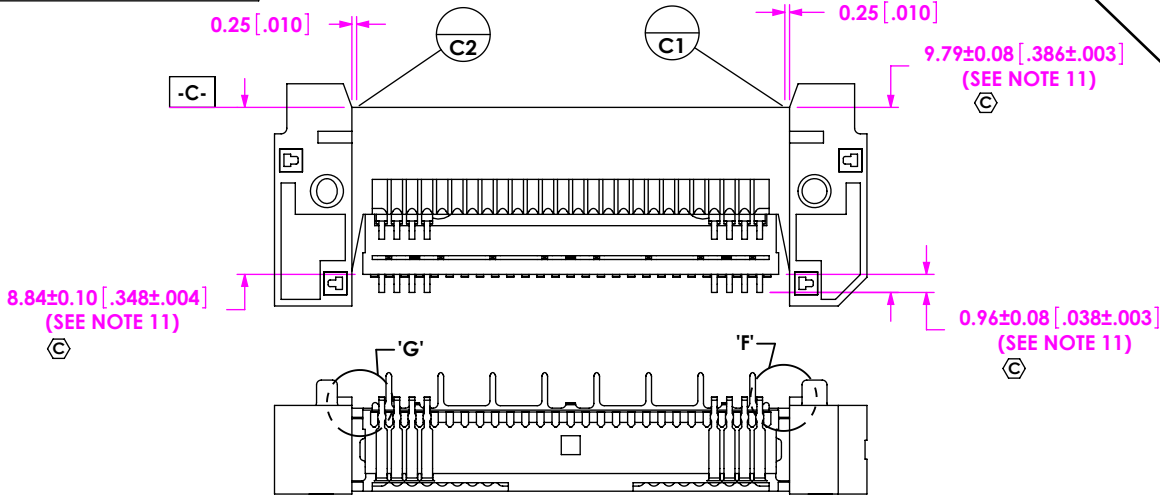

INSPECTION FOR IN PROCESS 6, 7 & 8
 (CARRIER NOT SHOWN FOR IN PROCESS 6 INSPECTIONS)

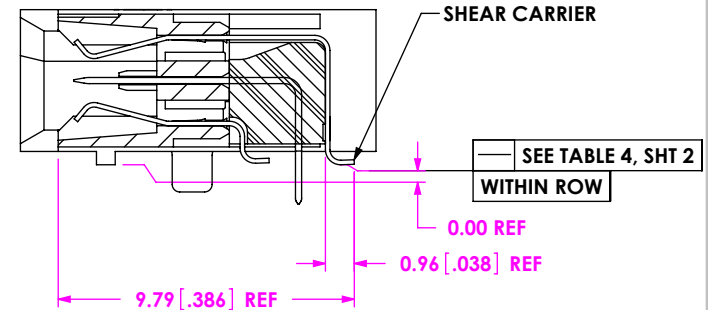

IN PROCESS 8
(CUTOFF OF CARRIER)
 (SEE INSPECTION VIEW 2 FOR ASSEMBLY ORIENTATION AND CPC'S)

PROPRIETARY NOTE
 THIS DOCUMENT CONTAINS INFORMATION CONFIDENTIAL AND PROPRIETARY TO SAMTEC, INC. AND SHALL NOT BE REPRODUCED OR TRANSFERRED TO OTHER DOCUMENTS OR DISCLOSED TO OTHERS OR USED FOR ANY PURPOSE OTHER THAN THAT WHICH IT WAS OBTAINED WITHOUT THE EXPRESSED WRITTEN CONSENT OF SAMTEC, INC.

DO NOT SCALE DRAWING
 SHEET SCALE: 4:1



520 PARK EAST BLVD, NEW ALBANY, IN 47150
 PHONE: 812-944-6733 FAX: 812-948-5047
 e-Mail info@SAMTEC.com code 55322

DESCRIPTION:
0.8mm Q-RATE RIGHT ANGLE SOCKET ASSEMBLY

DWG. NO.
QRF8-XXX-XX-X-RA-GP-XX

BY: R MUSSER 09/19/2008 SHEET 4 OF 5

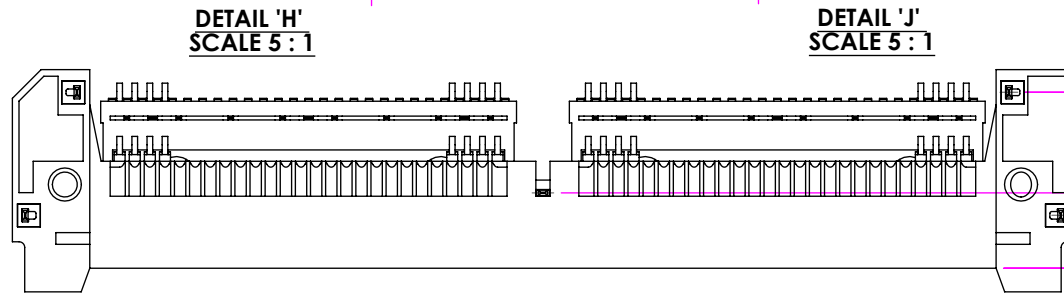
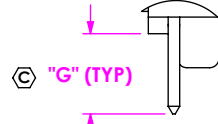
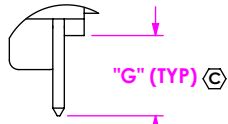
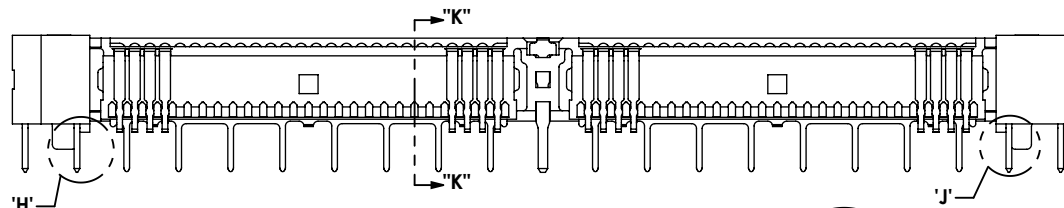

IN PROCESS 9
(FILL WELD TAB)
(WT-36-XX-T)

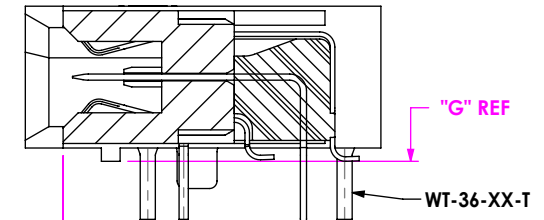

3.99 [.157] REF
(-052 & -078 ONLY)

"G" REF

WT-36-XX-T

6.51 [.256] REF

9.31 [.367] REF

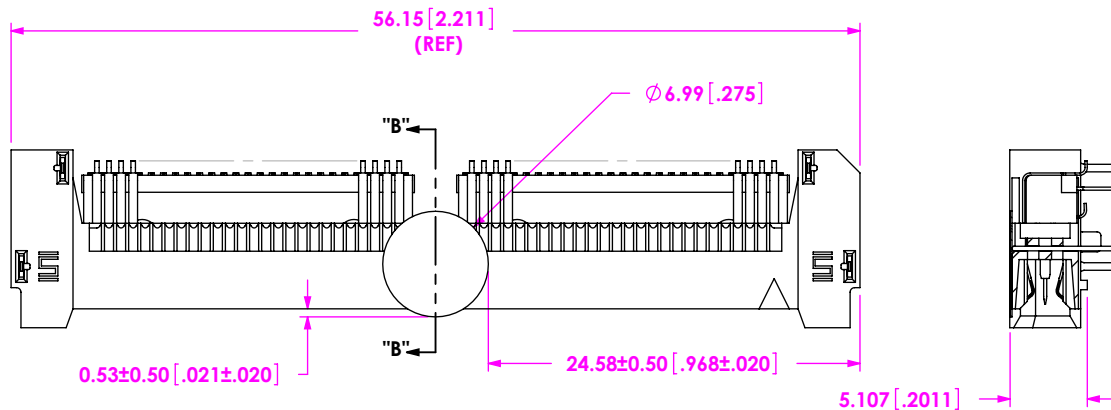

FIG 2
-K OPTION
(USE K-500-300)
(ONLY FOR QRF8-052-02-X-RA-GP-K SHOWN)
(SOME DETAIL REMOVED FOR CLARITY)

SECTION "B"-"B"
SCALE 2 : 1

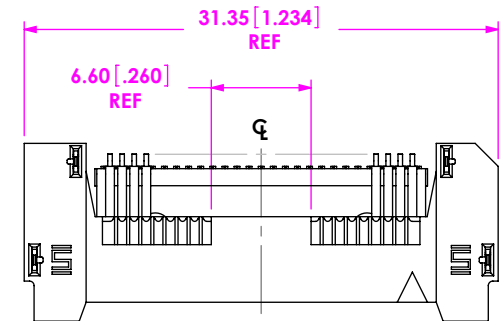

FIG 3
(QRF8-026-02-X-RA-GP SHOWN)
(SOME DETAIL REMOVED FOR CLARITY)

PROPRIETARY NOTE
THIS DOCUMENT CONTAINS INFORMATION
CONFIDENTIAL AND PROPRIETARY TO
SAMTEC, INC. AND SHALL NOT BE REPRODUCED
OR TRANSFERRED TO OTHER DOCUMENTS OR
DISCLOSED TO OTHERS OR USED FOR ANY
PURPOSE OTHER THAN THAT WHICH IT WAS
OBTAINED WITHOUT THE EXPRESSED WRITTEN
CONSENT OF SAMTEC, INC.

DO NOT SCALE DRAWING

SHEET SCALE: 4:1

samtec

520 PARK EAST BLVD, NEW ALBANY, IN 47150
PHONE: 812-944-6733 FAX: 812-948-5047
e-Mail info@SAMTEC.com code 55322

DESCRIPTION:
0.8mm Q-RATE RIGHT ANGLE SOCKET ASSEMBLY

DWG. NO.
QRF8-XXX-XX-X-RA-GP-XX

BY: R MUSSER 09/19/2008 SHEET 5 OF 5