

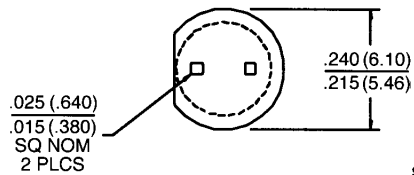

PLASTIC SILICON PHOTOTRANSISTOR

QSD122/123/124

PACKAGE DIMENSIONS

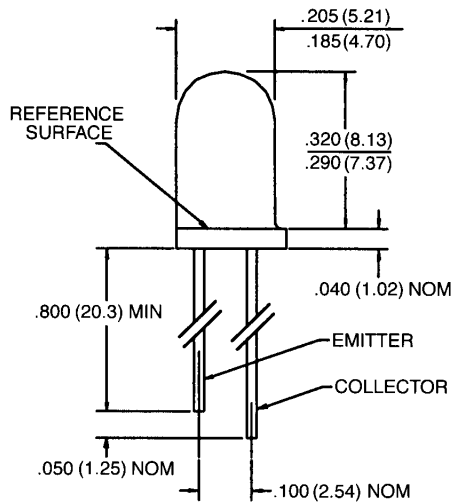

ST2144

DESCRIPTION

The QSD12X is a silicon phototransistor encapsulated in an infrared transparent, black T-1 $\frac{1}{4}$ package.

FEATURES

- Tight production distribution.
- Steel lead frames for improved reliability in solder mounting.
- Good optical-to-mechanical alignment.
- Narrow reception angle.
- Plastic package is infrared transparent black to attenuate visible light.
- Mechanically and spectrally matched to the QED123/222 LED.
- Black plastic body allows easy recognition from LED.

NOTES:

1. DIMENSIONS ARE IN INCHES (mm).
2. TOLERANCE IS $\pm .010$ (.25) UNLESS OTHERWISE SPECIFIED.
3. FLAT DENOTES EMITTER.



PLASTIC SILICON PHOTOTRANSISTOR

ABSOLUTE MAXIMUM RATINGS ($T_A = 25^\circ\text{C}$ Unless Otherwise Specified)

Storage Temperature	-40°C to + 100°C
Operating Temperature	-40°C to + 100°C
Soldering:	
Lead Temperature (Iron)	240°C for 5 sec. ^(2,3,4,5)
Lead Temperature (Flow)	260°C for 10 sec. ^(2,3,5)
Collector-Emitter Breakdown Voltage	30 Volts
Emitter-Collector Breakdown Voltage	5.0 Volts
Power Dissipation	100 mW ⁽¹⁾

ELECTRICAL CHARACTERISTICS ($T_A = 25^\circ\text{C}$ Unless Otherwise Specified)

(All measurements made under pulse conditions.)

PARAMETER	SYMBOL	MIN.	TYP.	MAX.	UNITS	TEST CONDITIONS
Collector-Emitter Breakdown	BV_{CEO}	30	—	—	V	$I_C = 1.0 \text{ mA}$
Emitter-Collector Breakdown	BV_{ECO}	5.0	—	—	V	$I_E = 100 \mu\text{A}$
Collector-Emitter Leakage	I_{CEO}	—	—	100	nA	$V_{CE} = 10 \text{ V}$
Reception Angle at 1/2 Sensitivity	θ	—	± 12	—	Degrees	
On-State Collector Current QSD122	$I_{C(ON)}$	1.0	—	6.0	mA	$E_e = 0.5 \text{ mW/cm}^2, V_{CE} = 5\text{V}^{(6)}$
On-State Collector Current QSD123	$I_{C(ON)}$	4.0	—	16.0	mA	$E_e = 0.5 \text{ mW/cm}^2, V_{CE} = 5\text{V}^{(6)}$
On-State Collector Current QSD124	$I_{C(ON)}$	6.0	—	—	mA	$E_e = 0.5 \text{ mW/cm}^2, V_{CE} = 5\text{V}^{(6)}$
Rise Time	t_r	—	7.0	—	μS	$I_C = .2 \text{ mA}, V_{CC} = 5 \text{ V}, R_L = 100\Omega$
Fall Time	t_f	—	7.0	—	μS	$I_C = .2 \text{ mA}, V_{CC} = 5 \text{ V}, R_L = 100\Omega$
Saturation Voltage	$V_{CE(SAT)}$	—	—	0.40	V	$I_C = 0.50 \text{ mA}, E_e = 0.5 \text{ mW/cm}^2^{(6)}$

NOTES

1. Derate power dissipation linearly 1.33 mW/°C above 25°C.
2. RMA flux is recommended.
3. Methanol or Isopropyl alcohols are recommended as cleaning agents.
4. Soldering iron tip 1/16" (1.6 mm) minimum from housing.
5. As long as leads are not under any stress or spring tension.
6. Light source is an AlGaAs LED emitting light at a peak wavelength of 880 nm.