

QUAD 606
Power Amplifier
Service Data

QUAD 606

Quad Electroacoustics Ltd.,
St. Peters Road, Huntingdon,
Cambs PE18 7DB England.
Telephone 0480 52561
Telex 32348 QUAD G
Fax 0480 413403

QUAD 606 service data

CONTENTS

	PAGE
Description	3
Specifications	4
Back View	5
Dismantling for Service	6
Replacing Mains Transformer.....	7
Changing Mains Voltage.....	8
Service Notes.....	9
Amplifier Performance Testing.....	10
Modifications.....	12
Fitting Link to Issue 1 and 2 PCB	13
Modified Mains Transformer Suspension	14
Mains Transformer Suspension (Before s/no 7000).....	15
Exploded View.....	16
Parts List	17
Rectifier 'T' Board PCB Layout.....	25
Pre Rectifier 'T' Board Wiring	25
Main Wiring Layout.....	26
Amplifier PCB Layouts. Issue 1 and 2 PCB.....	28
Issue 3 PCB	30
Circuit Diagrams: Issue 1 and 2 PCB.....	29
Issue 3 PCB	31

DESCRIPTION

The Quad 606 is a two channel power amplifier primarily intended for use in high quality sound reproducing systems. The amplifier is usually used in conjunction with a Quad control unit though other signal sources can readily be accommodated.

The amplifier uses a current dumping output circuit, a Quad invention which eliminates many of the problems associated with transistor amplifiers, and is covered by patents in several countries.

In a current dumping amplifier there is, in effect, both a low power very high quality Class A amplifier and a high power heavy duty amplifier. The low power Class A amplifier controls the loudspeakers at all times, calling upon the high power amplifier to provide most of the muscle. The small Class A amplifier is so arranged – it carries an error signal – that provided the larger power transistors (the current dumpers) of the high power amplifier get within the target area of the required output current, it will fill in the remainder accurately and completely.

The reproduced sound quality is *solely* dependent on the small Class A amplifier which, because of its low power can be made very good indeed. Problems of crossover distortion, quiescent current adjustment, thermal tracking, transistor matching, all disappear. There are no internal adjustments or alignment required and the choice of power transistor types is less restricted.

The Quad 606 is a very powerful amplifier and is capable of very high power output levels and should only be used with suitably rated loudspeakers.

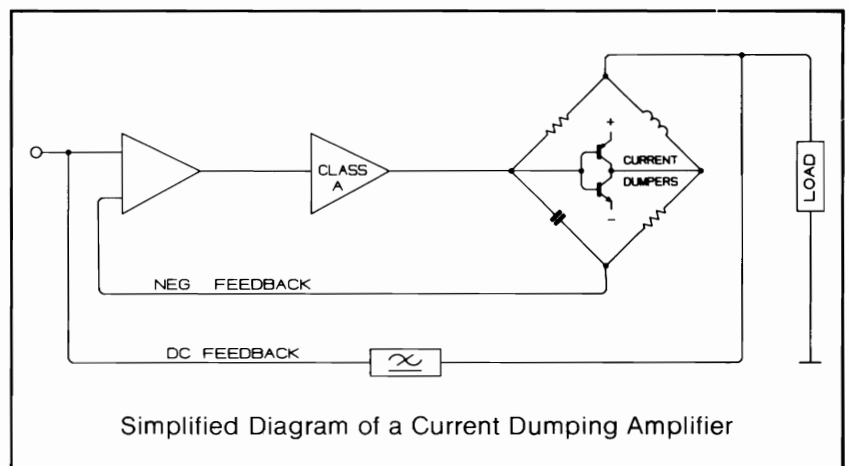

QUAD 606 service data

SPECIFICATIONS

Measurements apply to either channel.
All measurements made at 230V 50Hz AC.

POWER OUTPUT:

See graph. Max current 12A peak.

DISTORTION:

Continuous sine wave into 8Ω resistive load
20Hz- any level up to 130W < 0.01%
1kHz any level up to 130W < 0.01%
20kHz any level up to 130W < 0.03%

OUTPUT INTERNAL IMPEDANCE AND OFFSET:

1.5μH in series with 0.05Ω. Offset typically 7mV.

FREQUENCY RESPONSE:

Reference 1 kHz
-0.25dB at 20Hz and 20kHz
-1.0dB at 13Hz and 40kHz

POWER RESPONSE:

Reference 1 kHz
-0.25dB at 20Hz and 20kHz

SIGNAL INPUT LEVEL:

0.5V for 140W output into 8Ω
Amplifier loads the input by 20kΩ

SIGNAL INPUT OVERLOAD:

Instantaneous recovery up to +15dB overload.

CROSSTALK:

Input loaded by 1 kΩ
-100dB at 100Hz
-85dB at 1 kHz
-65dB at 10kHz

HUM AND NOISE:

Unweighted -105dB reference 140W
(15.7kHz measurement bandwidth)

STABILITY:

Unconditionally stable with any load or signal.

AC INPUT:

110-120V or 220-240V, (50-60Hz), 30-850W
Depending on signal level

WEIGHT:

12.0 Kg.

DIMENSIONS:

321 mm wide, 140 mm high, 240 mm deep.

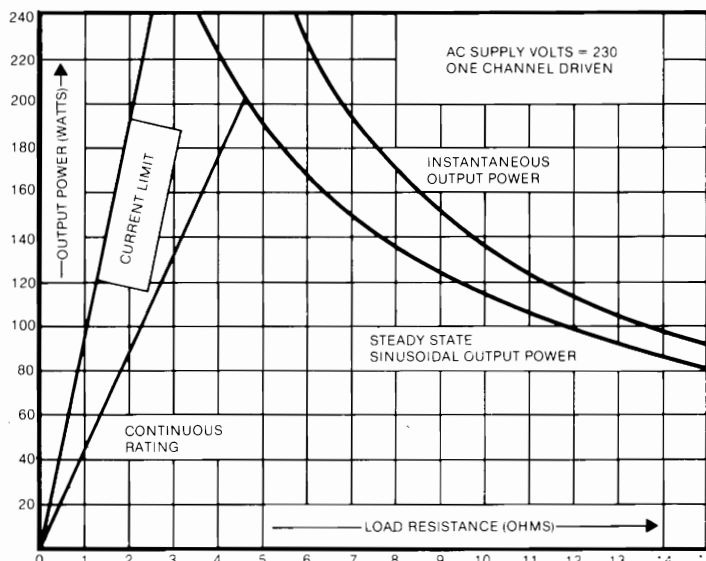

QUAD 606 service data

BACK VIEW

FIXING SCREWS FOR CENTRAL SURROUND
AND REAR SOCKET PANEL

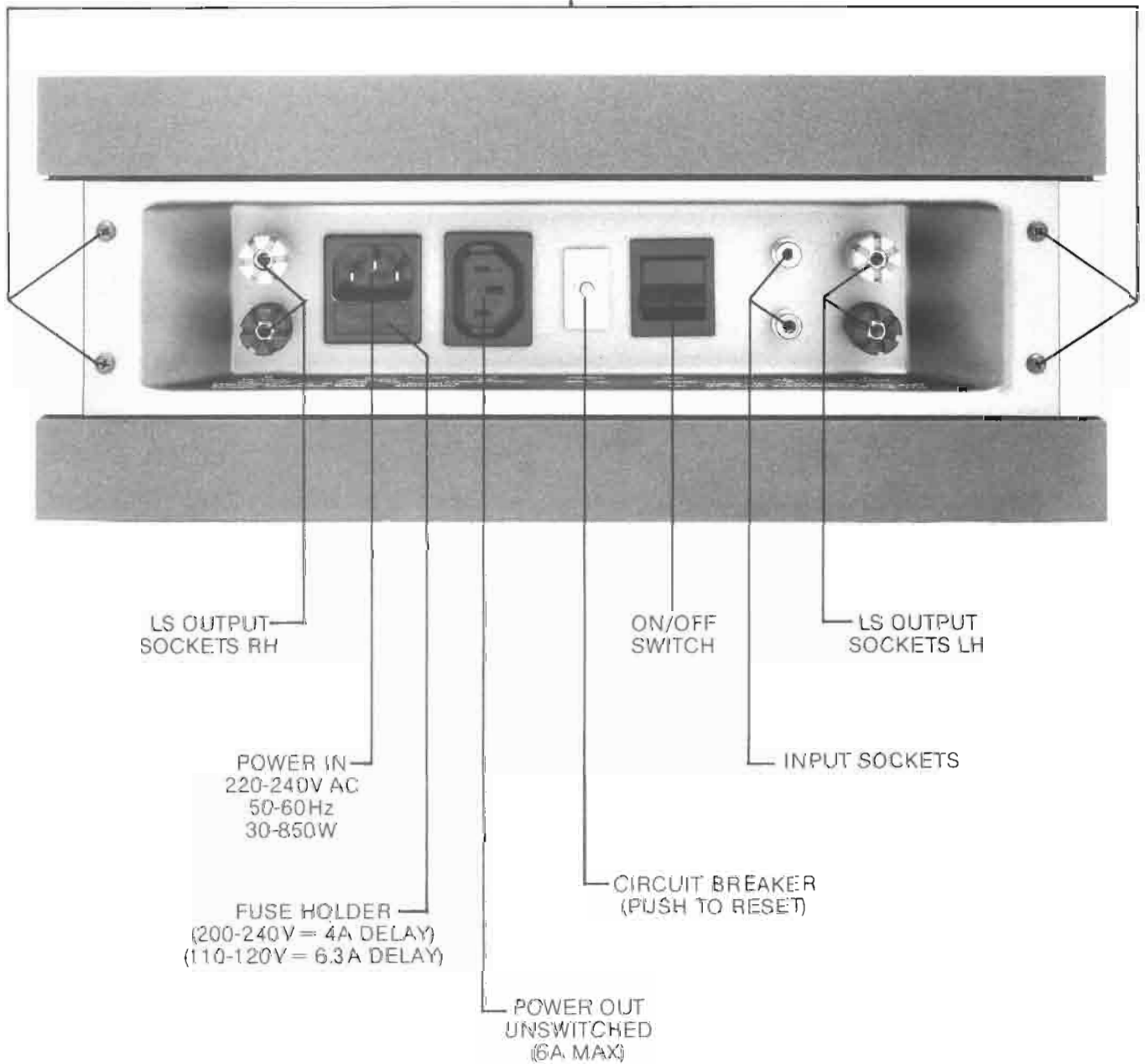

Q U A D 606 service data

DISMANTLING FOR SERVICE

All normal servicing can be carried out by removing the bottom cover/heatsink assembly. Proceed as follows:-

- (a) Disconnect from mains supply.
- (b) Remove lower 2 screws on rear socket panel (also lower 2 screws where fitted on central surround trim).
- (c) Loosen top 2 screws on rear socket panel a few turns.
- (d) Remove 4 bottom feet (take care not to lose the 4 rubber inserts).
- (e) Remove the 4 countersunk screws just inside the feet positions.
- (f) Remove bottom cover – the cover is a snug fit so some pressure (light tapping) may be required around the edges, be careful not to scratch/damage the paintwork.

Each amplifier board can be taken out for repair or replacement as follows:

- (a) Carefully remove the 6 push-fit connection tags (note colour code and connections).
- (b) Remove the 3 fixing screws holding the board to the top cover/heatsink. A long screwdriver is required for this which can go through the holes in the heatsink (outer 2 screws only).

When refitting, care must be taken to ensure that the heatsink contact surfaces are clean and flat – also a layer of silicon thermal paste must be applied, but only to the top cover/heatsink contact areas.

If necessary the rear socket panel assembly can be detached by removing the remaining 2 top fixing screws – be careful not to break any wiring.

The central surround trim can be removed completely by gently opening at the back and lifting forward to slip over the green on/off LED (on earlier models the surround was fixed by 4 separate fixing screws).

NOTE:

When refitting surround trim be careful not to break or bend it and ensure that the green on/off LED protrudes through the hole provided.

Q U A D 606 service data

To reassemble:-

- (a) If central surround trim has been removed first fit it and the top 2 screws on rear socket panel (also top 2 trim screws where fitted) – do not fully tighten screws but leave loose.
- (b) Place bottom cover in position and press home – due to the snug fit this may take some easing into position – a screwdriver inserted into the bottom fixing holes usually helps.
- (c) Fit 4 centre countersunk screws and 4 feet and fully tighten – do not lose rubber inserts.
- (d) Fit lower 2 screws on rear socket panel (also lower 2 trim screws where fitted).
- (e) Fully tighten all screws on rear socket panel and trim, ensuring that the trim is correctly positioned.

REPLACING MAINS TRANSFORMER

The mains transformer fitted is a heavy duty high quality component therefore failure is unlikely but should it be necessary to replace it proceed as follows:

- (a) Remove bottom cover, decorative surround trim and detach rear socket panel as explained in 'Dismantling for Service'.
- (b) Unsolder primary and secondary wires to transformer (note connections).
- (c) Either unsolder wires to on/off LED plate or remove LED plate assembly (one screw).
- (d) Disconnect red and black tags to both amplifier boards.
- (e) Remove the 4 fixing screws to the power supply chassis. The whole power supply assembly can now be swung out to allow access to the transformer (take care not to strain any connections).
- (f) The transformer can now be taken out by removing the 4 nuts/studs and lifting off the 2 retaining bars.
- (g) Refit in reverse order and ensure that the retaining bars are fitted with foam pads and that the screwed pillars are rubber covered. If not these should be replaced using the "Mains Transformer Modified Suspension Kit" (part number Q60SUSP). This would apply to amplifiers before s/no 3000.
- (h) Re-assemble the power supply chassis, reconnect the red/black tags to amplifier boards and re-fit LED plate. Ensure no leads are trapped or shorting.
- (i) Re-assemble complete amplifier.

Q U A D 606 service data

CHANGING MAINS VOLTAGE

The Quad 606 is normally supplied for 220/240V 50Hz AC operation. Links are provided on the mains transformer for 110/120V operation but the circuit breaker and mains fuse must also be replaced with the correct rating.

- (a) Remove bottom cover as shown in 'Dismantling for Service' and stand amplifier on its front face, to gain access to the transformer tags. It may help to detach and tilt-up the rear socket panel assembly.
- (b) Solder links as shown below to the primary tags and fit correct circuit breaker and mains fuse:-

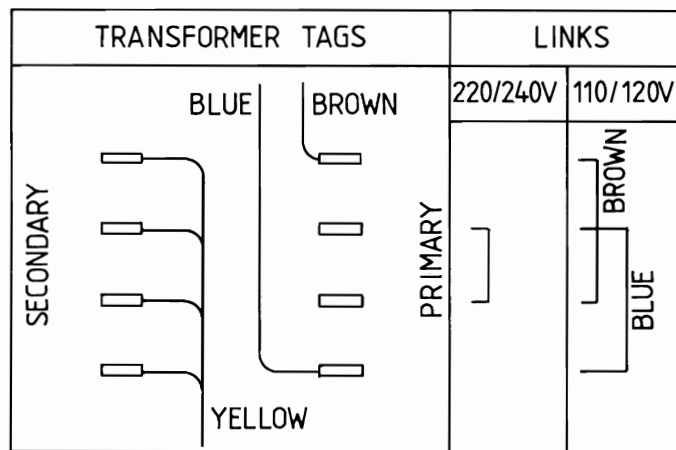

220/240V: Connect tags as shown using tinned copper link wire.

Circuit breaker 2A

Part number SP606AA

Fuse T4A

Part number UM04ADA

Rear Panel Label 220/240V

M20141A

110/120V:

Connect centre tags using brown and blue link wire.

Circuit breaker 4A

Part number SP606AB

Fuse T6A3

Part number UM6A3DA

Rear Panel Label 110/120V

M20141B

- (c) Assemble in reverse order.

IMPORTANT:

Ensure Quad 606 is clearly labelled to show voltage range set.

SERVICE NOTES

- (a) When replacing driver and output transistors it is imperative that new thermal conduction 'SIL' pads are fitted, **DO NOT RE-USE OLD PADS**. Also the 'Belleville' copper finish washers and heatsink washers must be refitted. Should heatsinks be removed they must be firmly reseated with heat conductive silicon paste.
- (b) The centre tapped DC Line (+55V, -55V) is floating and some faults may cause this to shift putting up to 110V on one side – possibly damaging R38 and R39 (2k2 ohm).
These components should always be checked during repairs.

QUAD 606 service data

AMPLIFIER PERFORMANCE TESTING

TEST EQUIPMENT REQUIREMENTS

1. Oscilloscope
2. Distortion Analyser
3. AF Signal Generator Sine/Square
4. Audio multivoltmeter
5. Multimeter
6. Dummy loads 8Ω (140W), 4Ω (225W), 1.414Ω (100W), 1Ω (75W)

(a) AC QUIESCENT CURRENT

Test under no signal conditions

240V Typically 60mA
120V Typically 120mA

(b) DC SUPPLY

Test under no signal conditions. +Ve and -Ve supply rails to be approximately 53–56V DC.

(c) INPUT SENSITIVITY

With dummy 8Ω load connected drive LH channel at 1kHz for 140W output (33.46V). Input to be $0.5V \pm 0.5dB$. Increase input and ensure no instability appears at clipping point. Repeat for RH channel.

(d) DISTORTION

With dummy 8Ω load connected drive LH channel for 130W output (32.25V). Distortion to be as shown for the following frequencies. Repeat for RH channel.

100Hz < 0.01%
1 kHz < 0.01%
3kHz < 0.01%
10kHz < 0.03%
20kHz < 0.03%

(e) LOW OUTPUT DISTORTION

With dummy 8Ω load connected check LH and RH channels at 1kHz and 1W output (2.828V). Check for clean undistorted waveform and no sign of instability.

(f) SQUARE WAVE PERFORMANCE

With dummy 8Ω loads connected drive LH and RH channels with 3kHz square wave at approximately 300mV. Vary input level but avoid clipping. Check for clean waveforms. Remove loads and check for overshoot.

(g) FREQUENCY RESPONSE

With dummy 8Ω load connected drive LH channel at 1kHz for 130W output (32.25V). Response should be within limits shown below, reference to 1kHz. Repeat for RH channel.

10Hz -3dB
20Hz -0.25dB
20kHz -0.25dB

(h) SIGNAL/NOISE RATIO

With dummy 8Ω load connected drive LH channel at 1kHz for 130W output (32.25V). Remove drive and short circuit input. Unweighted signal/noise ratio should be > -107dB (15.7kHz measurement bandwidth, -6dB per octave roll off above 10kHz). Repeat for RH channel.

'A' weighting will give approximately 6dB improvement.

Q U A D 606 service data

(i) CROSSTALK

With dummy 8Ω loads connected drive LH channel at 1kHz for 130W output (32.25V). Terminate input of RH channel with 1kHz and measure crosstalk at RH channel output, to be better than -85dB.

Repeat for RH channel driven and measure crosstalk at LH channel output.

(j) OUTPUT AT 4Ω

With dummy 4Ω load connected drive LH channel at 1kHz just prior to clipping. Output to be approximate 225W (30V) depending on temperature. Distortion < 0.01%. Repeat for RH channel.

(k) CURRENT OUTPUT DRIVE

With dummy 1.414Ω load connected drive LH channel at 1kHz and observe output on oscilloscope. The rms voltage measured just prior to clipping will equal the peak current in amps, nominally 11–12A.

Alternatively, if 1.414Ω resistors are not available use 1Ω resistors where an output of 7.78–8.49V rms equals a peak current of 11–12A.

Repeat for RH channel.

The circuit breaker will operate within approximately 4 seconds when hot and approximately 9 seconds when cold.

Q U A D 606 service data

MODIFICATIONS

- (1) **AUGUST 86**
(S/No 1050 APPROX.)
R42 10k ohm 5% (R10K0J4) added between collector/emitter of T3 on back of printed circuit board. R8 increased from 180 Ω to 270 Ω (R270RJ4). To improve high frequency overload performance (stability).
- (2) **NOVEMBER 86**
(S/No 1751 APPROX.)
Rectifier block changed from PM7A2Q to KBU8DX (DKBU8DX) mounted on 'T' board with capacitor C15 and fuse.
- (3) **DECEMBER 86**
(S/No 2000 APPROX.)
R11 reduced from 9R1 Ω to 7R5 Ω (R7R50F4) (sometimes 39 Ω across R11). To enable 606 to meet specification of 140W output for 0.5V input.
- (4) **JANUARY 87**
(S/No 2200 APPROX.)
2 x 40nF capacitors (C40N0M1) fitted to back of 'T' board between secondary windings and earth. To cure rectifier interference.
- (5) **MARCH 87**
(S/No 3000 APPROX.)
New transformer mountings to reduce mechanical noise. Modification kit Q60SUSP (see page 14).
- (6) **MARCH 87**
(S/No 3200 APPROX.)
Printed circuit board Iss. 2 introduced. Incorporating R42 10k Ω 5% (R10K0J4) on component side (see Mod 1).
- (7) **APRIL 87**
(S/No 3400 APPROX.)
New rectifier 'T' board introduced with 2 x 470nF (C470NKS) capacitors C18, C19 in place of 470nF C15 (C470NKS).
- (8) **MAY 87**
(S/No 3800 APPROX.)
Binding posts fitted for loudspeaker outputs.
- (9) **JUNE 87**
(S/No 4500 APPROX.)
Shorting link of 16 SWG (1.5mm) tinned copper wire connected across PCB track earths. (see page 13). 330nF (C330NXA) capacitor C20 fitted across mains transformer primary. To reduce interference from electrical appliances (thermostats etc).
- (10) **NOVEMBER 87**
(S/No 5700 APPROX.)
Printed circuit board Iss. 3 introduced to improve screening and reduce interference from electrical appliances. R14, R15 and CR1 taken to R20, R26 supply rail, to improve performance.
- (11) **MARCH 88**
(S/No 7000 APPROX.)
New transformer mountings and power supply chassis to reduce mechanical hum.

Q U A D 606 service data

FITTING LINK TO ISSUE 1 AND 2 PCB

(See page 12, Mod (9))

In cases of interference from household appliances, thermostats etc., connect a link across the track side of each amplifier printed circuit board as shown below.

- (a) Scratch the protective lacquer from each PCB at the two points marked 'O' adjacent to 'C9, R3' and 'IN' respectively, and connect an insulated piece of 16 swg (1.5mm) tinned copper wire between these points as indicated.
- (b) For very severe cases a 330nF 250V AC working capacitor (C20) may also be connected directly across the mains transformer primary connections.

These modifications were incorporated in production models with Issue 2 PCB, from S/No. 4500.

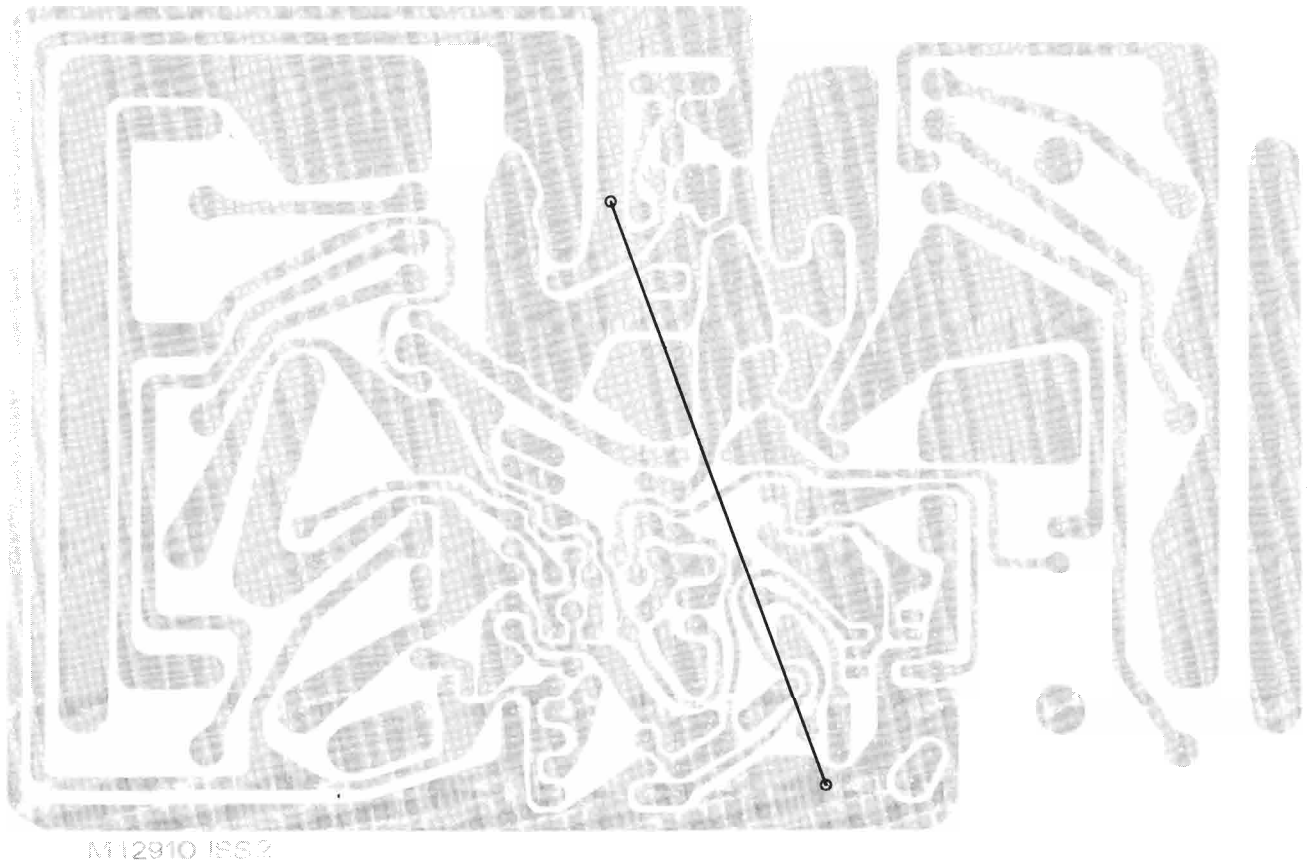

Q U A D 606 service data

MODIFIED MAINS TRANSFORMER SUSPENSION

(See page 12, Mod (5))

It has been discovered that the mains transformer can shift in transit if the amplifier is handled roughly. The transformer then bears against a mounting stud which transmits vibration to the case.

A revised transformer suspension has been fitted to all 606 from S/No 3000. Suspension modification kits are available (part no. Q60SUSP) and can be fitted to early model amplifiers which prove to be noisy.

Please note that the new transformer mountings and power supply chassis fitted from S/No 7000 cannot be retrofitted.

FITTING INSTRUCTIONS FOR SUSPENSION KIT Q60SUSP

- (a) Remove the LED board (one screw).
- (b) Remove the four screws which hold the power supply chassis.
- (c) Disconnect the HT supply tags to both boards.
- (d) The power supply chassis can now be swung out. Take care not to strain the connections to the mains transformer.
- (e) Remove the four screws holding down the two transformer retaining bars. Lift off the retaining bars and unscrew the four pillars.
- (f) Insert the new rubber covered pillars with shorter threaded end into heatsink and screw tight.
- (g) Affix the two foam pads centrally to the lower (flat) side of the two retaining bars using the double sided tape.
- (h) Refit the two retaining bars with the foam pads downwards so that they press onto the transformer. Fit the retaining nuts and tighten firmly.
- (i) Re-assemble the power supply chassis, reconnect the HT supplies and refit the LED board.

This modification reduces the hum level by about 15dB (x 1/5) and will cure all problems of mechanical hum unless the bonding between the faces of the Transformer cores has broken down.

Q U A D 606 service data

TRANSFORMER SUSPENSION BEFORE S/No. 7000

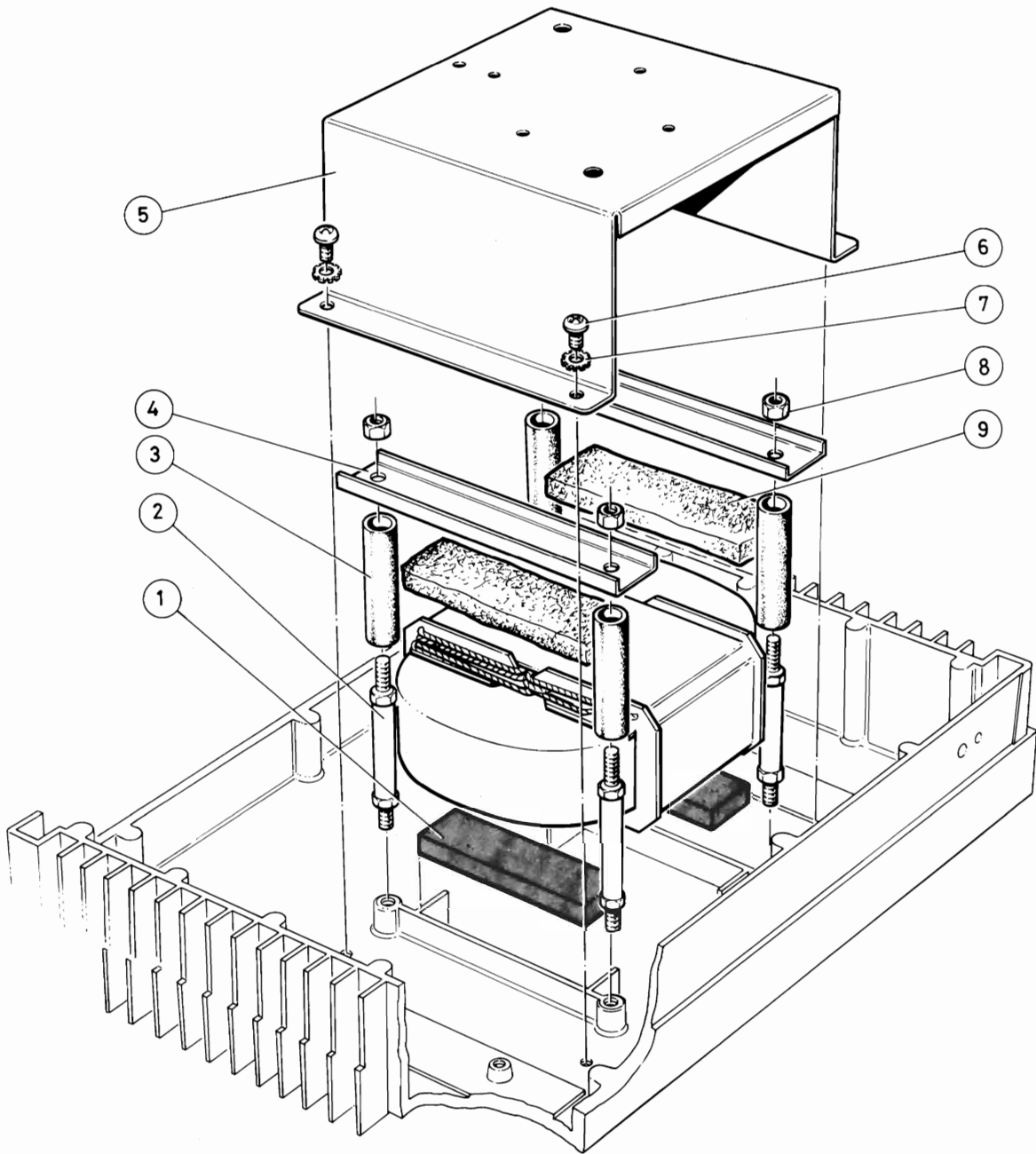

Ref.	Description	Qty	Part No.
1	Rubber Blocks	2	M2O151A
2	Mains Transformer Studs*	4	M20661A
3	Rubber Tube 5mm ID/3mm Wall (cut to 45mm)*	4	AT0503A
4	Mains Transformer Brackets*	2	M12867A
5	Power Supply Chassis	1	M20351A
6	Screw M4 x 6 Sup. Pan BZP STL	4	TM406PA
7	Washer Shakeproof M4 STL	4	TDM4NLA
8	Nut M5 Full Hex BZP STL*	4	TM5FHPA
9	Foam Packing*	2	ICHFOMA

*Supplied as Suspension Kit Q60SUSP

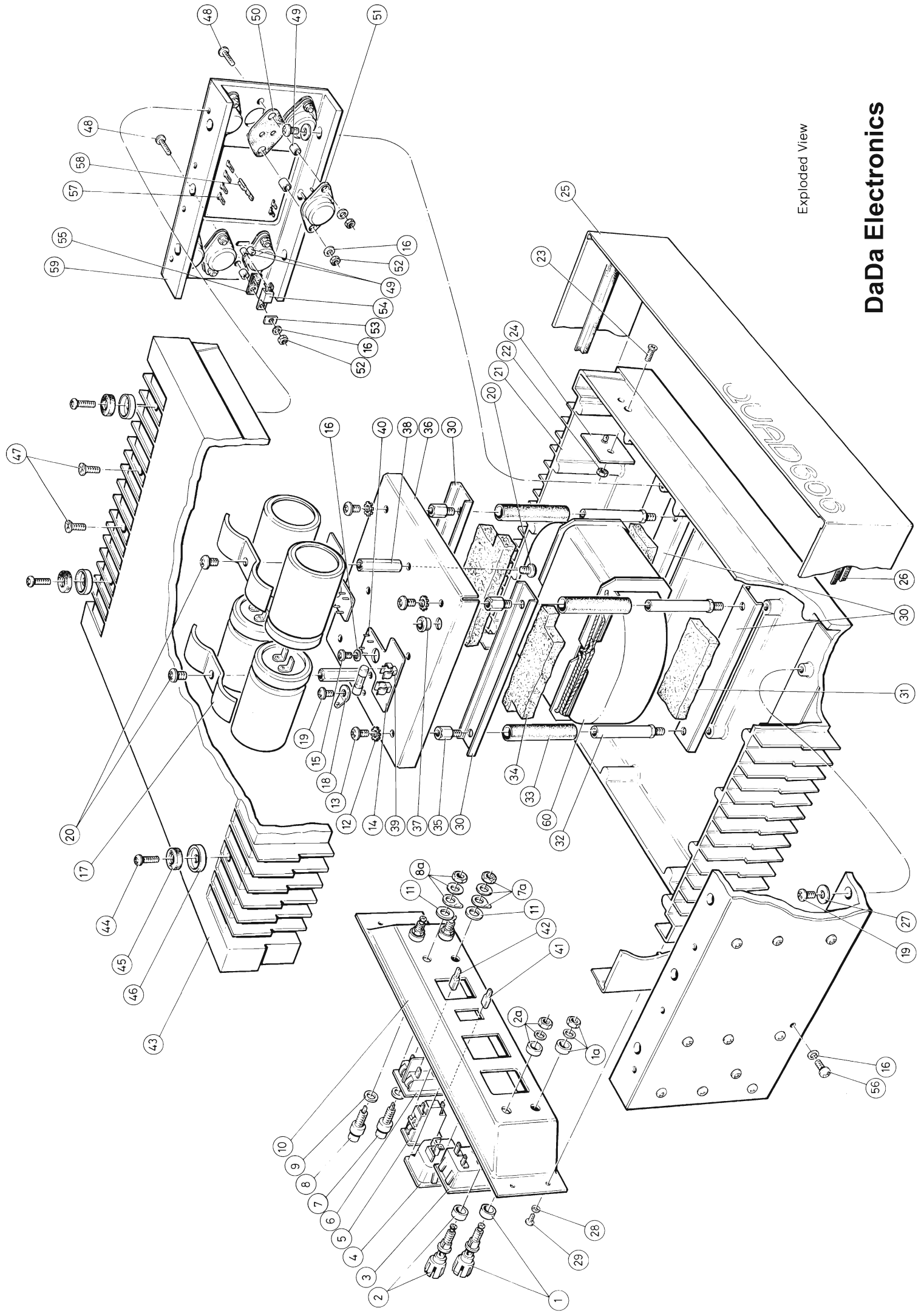

Exploded View

DaDa Electronics

PARTS LISTS

ORDERING SPARE PARTS

To allow for modifications etc. please quote component reference, value and description as well as the part number, when ordering spares. Also product model and serial number.

MECHANICAL PARTS (SEE EXPLODED VIEW)

Ref.	Description	Qty	Part No.
1	Terminal Post Red 30A (After S/No. 3800) C/W Fixings 1a (SK2)	2	PTPOST2
-	Socket 4mm Red (Before S/No. 3800) C/W Fixings (SK2)	2	PSRS14C
2	Terminal Post Black 30A (After S/No. 3800) C/W Fixings 2a (SK2)	2	PTPOST0
-	Socket 4mm Black (Before S/No. 3800) C/W Fixings (SK2)	2	PSBS14C
3	Mains Input Plug/Fuse Holder Euro (PL1)	1	PPF333C
4	Mains Outlet Socket Euro Moated (SK4)	1	PSP695S
5	Circuit Breaker 2A 240V (N1)*	1	SP606AA
6	Mains On/Off Switch (S1)	1	S2600HA
7	Phono Socket White C/W Fixings 7a (SK1)	1	PSPHOG9
8	Phono Socket Red C/W Fixings 8a (SK1)	1	PSPHOG2
9	Bush for Phono Sockets	2	M12716A
10	Rear Socket Panel	1	M20512A
11	Washer Neoprene 6mm Bore	2	AW1406A
12	Washer Shakeproof M5 STL	4	TDM5NLA
13	Screw M5 x 6 Pos. Pan BZP STL	4	TM506PA
14	Rectifier Sub Assembly Complete 'T' Board	2	Q60REPA
15	Screw M3 x 12 Sup. Pan BZP STL	2	TM312PA
16	Belleville Spring Washer	32	TD73206
17	Capacitor Clip	2	M12866A
18	Solder Tag	1	FT2006A
19	Screw M4 x 6	7	TM406PA
20	Screw M4 x 8	4	TM408PA

QUAD 606 service data

Ref.	Description	Qty	Part No.
21	Top Cover	1	M12862H
22	Nut M3 Full Hex BZP STL	1	TM3FHPA
23	Screw M3 x 8 CSK BZP STL	1	TM308CA
24	LED Sub Assembly Complete	1	Q60LEPA
25	Central Surround Trim C/W Extrusion 26	1	Q60TRIM
-	Central Surround Trim only	1	M60TRIG
26	Top Hat Extrusion	1	M20201A
27	Washer M4.4 x 12.5 x 0.8	6	TDM4NPA
28	Washer Shakeproof M3 STL	4	TDM3NLA
29	Screw M3 x 6 Sup. Pan. Black STL	4	TM306PF
30	Mains Transformer Brackets	4	M20981A
31	Foam Packing	2	ICHFOMA
32	Mains Transformer Studs	4	M20662A
33	Rubber Tube 5mm ID/3mm Wall (Cut to 45mm)	4	AT0503A
34	Transformer Mounting Sponge	2	M21471A
35	Spacer M5 x 10 Hex	4	TS510HA
36	Power Supply Chassis	1	M20352A
37	Nylon Bush B312-250 Black	2	NB31225
38	Capacitor Clip Spacer	2	M21011A
39	Fuse Clips E1073 (After S/No. 1750)	4	PFC073A
-	Fuse Holder L2390 (Before S/No. 1750)	2	PFL2390
40	PCB Stud	8	PAM9341
41	Shakeproof Terminal 2006-1	1	FT2006A
42	Shrouded Receptacle 0.25"	-	PS025 RA
43	Bottom Cover	1	M12862G
44	Screw M4 x 10 Pan Black STL	4	TM410PB
45	Rubber Foot Insert	4	M20172A
46	Metal Foot Anodised Black	4	M606FTB

Q U A D 606 service data

Ref.	Description	Qty	Part No.
47	Screw M4 x 10 Pos. CSK Sup Black STL	4	TM410CF
48	Screwed Stud M3 Self Broaching	28	M20381A
49	Nylon Insulating Bush 5mm	36	M12577C
50	Transistor Washer TO3	12	IWTO3XX
51	Transistor 17556	12	D17556X
52	Nut M3 Full Hex BZP STL	28	TM3FHPA
53	Transistor Metal H/S Washer TO220	4	DNR231A
54	Transistor 40872-K	4	D40872X
55	Transistor Washer TO220	4	IWTO220
56	Screw M3 x 6 Self Tapping	2	TC306PA
57	Amp Connector PCB Mounting (735187-2)	12	PAM1872
58	Amp Connector (341035-2)	12	PAM0352
59	Amplifier Sub Assembly C/W Heatsink	2	Q60PCBA
-	Heatsink only	2	M12868A
60	Mains Transformer 120-240V (L1)*	1	L12886A

*See main parts list for other voltage range part numbers.

Q U A D 606 service data

RESISTORS

Ref.	Description				Qty	Part No.
R1	560 Ω	5%	0.25W	Carbon Film		R560RJ4
R2	22k Ω	5%	0.25W	Carbon Film		R22K0J4
R3	5k6 Ω	5%	0.5W	Carbon Film		R5K60J2
R4	33 Ω	5%	0.25W	Carbon Film		R33R0J4
R5	120k Ω	5%	0.25W	Carbon Film		R120KJ4
R6	22k Ω	5%	0.25W	Carbon Film		R22K0J4
R7	10 Ω	5%	0.5W	Carbon Film		R10R0J2
R8	270 Ω	5%	0.25W	Carbon Film		R270RJ4
R9	330 Ω	5%	0.25W	Carbon Film		R330RJ4
R10	330 Ω	5%	0.25W	Carbon Film		R330RJ4
R11	7R5 Ω	1%	0.25W	Metal Film		R7R50F4
R12	3k3 Ω	5%	0.5W	Carbon Film		R3K30J2
R13	10k Ω	5%	0.25W	Carbon Film		R10K0J4
R14	3k3 Ω	5%	0.25W	Carbon Film		R3K30J4
R15	330 Ω	5%	0.25W	Carbon Film		R330RJ4
R16	560 Ω	5%	2.5W	W.W. Welwyn Type X2B		R560RJO
R17	560 Ω	5%	2.5W	W.W. Welwyn Type X2B		R560RJO
R18	0R12 Ω	5%	2.5W	W.W. CGS Type CB3		R0R12JC
R19	22 Ω	5%	0.25W	Carbon Film		R22R0J4
R20	0R1 Ω	5%	2.5W	W.W. CGS Type CB3		R0R10JC
R21	0R1 Ω	5%	2.5W	W.W. CGS Type CB3		R0R10JC
R22	0R1 Ω	5%	2.5W	W.W. CGS Type CB3		R0R10JC
R23	22 Ω	5%	0.25W	Carbon Film		R22R0J4
R24	560 Ω	2%	3W	CGS Type TFP3		R560RGC
R25	2M2 Ω	5%	0.25W	Carbon Film		R2M20J4
R26	0R1 Ω	5%	2.5W	W.W. CGS Type CB3		R0R10JC
R27	0R1 Ω	5%	2.5W	W.W. CGS Type CB3		R0R10JC
R28	0R1 Ω	5%	2.5W	W.W. CGS Type CB3		R0R10JC

Q U A D 606 service data

Ref.	Description				Qty	Part No.
R29	22 Ω	5%	0.25W	Carbon Film		R22R0J4
R30	22 Ω	5%	0.25W	Carbon Film		R22R0J4
R31	0R1 Ω	5%	2.5W	W.W. CGS Type CB3		R0R10JC
R32	0R1 Ω	5%	2.5W	W.W. CGS Type CB3		R0R10JC
R33	10 Ω	5%	0.5W	Carbon Film		R10R0J2
R34	0R1 Ω	5%	2.5W	W.W. CGS Type CB3		R0R10JC
R35	12k Ω	5%	1.6W	Metal Film		R12K0JR
R36	10k Ω	1%	0.25W	Metal Film		R10K0F4
R37	9k1 Ω	1%	0.25W	Metal Film		R9K10F4
R38	2k2 Ω	5%	0.5W	Carbon Film		R2K20J2
R39	2k2 Ω	5%	0.5W	Carbon Film		R2K20J2
R40	10 Ω	5%	0.25W	Carbon Film		R10R0J4
R41	10k Ω	5%	0.25W	Carbon Film		R10K0J4
R42	10k Ω	5%	0.25W	Carbon Film		R10K0J4

CAPACITORS

Ref.	Description				Qty	Part No.
C1	330pF	10%	50V	Ceramic		C330PKJ
C2	100nF	10%	100V	-		C100NKA
C3	680nF	10%	63V	-		C680NKA
C4	330pF	10%	50V	Ceramic		C330PKJ
C6	330pF	10%	50V	Ceramic		C330PKJ
C7	47 μ F	20%	63V	5mm PCM		C47U0MM
C8	47pF	1%	350V	Silver Mica		C47P0FS
C9	200 μ F	-10 +50%	63V	-		C220UTA
C10	47nF	5%	250V	-		C47N0JS
C11	220 μ F	-10 +50%	63V	-		C220UTA
C12	6k8 μ F		63V	Tag Connection		C6K8UTA
C13	6k8 μ F		63V	Tag Connection		C6K8UTA

Q U A D 606 service data

Ref.	Description				Qty	Part No.
C14	4n7F	10%	50V	Ceramic		C4N70SJ
C15	470nF	10%	250V	-		C470NJM
C16	4n7F	-20 +80%	63V	-		C4N70ZM
C18	470nF	10%	100V	-		C470NKS
C19	470nF	10%	100V	-		C470NKS
C20	330nF	10%	250V AC	Plessey Type X2		C330NXA

SEMICONDUCTORS

Ref.	Description				Qty	Part No.
T1	Transistor BC214C					DBC214C
T2	Transistor MPSA43-K					DMPSA43
T3	Transistor BC413C					DBC413X
T4	Transistor MPSA93-K					DMPSA93
T5	Transistor MPSA93-K					DMPSA93
T6	Transistor MPSA93-K					DMPSA93
T7	Transistor 40872-99					D40872X
T8	Transistor 40872-99					D40872X
T9	Transistor 17556					D17556X
T10	Transistor 17556					D17556X
T11	Transistor 17556					D17556X
T12	Transistor 17556					D17556X
T13	Transistor 17556					D17556X
T14	Transistor 17556					D17556X
T15	Transistor ZTX652-K					DZTX652
T16	Transistor ZTX752-K					DZTX752
D1	Diode Zener 6V8 500MW					D886V8A
D2	Diode Zener 6V8 500MW					D886V8A
D3	Diode 1 N4148					D1N4148

Q U A D 606 service data

Ref.	Description	Qty	Part No.
D4	Diode 1 N4003 1 A 200V		D1 N4003
D5	Diode 1 N4003 1 A 200V		D1 N4003
D6	Diode 1 N4003 1 A 200V		D1 N4003
D7	Diode 1 N4003 1 A 200V		D1 N4003
D8	Diode 1 N4003 1 A 200V		D1 N4003
D9	Diode 1 N4003 1 A 200V		D1 N4003
D10	Diode LED (T1) Green 3mm		BLG124T
D11	Bridge Rectifier KBU8D (After S/No. 1751)		DKBU8DX
-	Bridge Rectifier PM7A2Q (Before S/No. 1751)		DPM7A2Q
D12	Diode Zener 6V8 500MW		D886V8A
CR1	Current Source LM334Z		DLM334Z
CR2	Diode Current Regulator J503		DJ503XX
IC1	Integrated Circuit TLC271 CP		DTLC271

MISCELLANEOUS

Ref.	Description	Qty	Part No.
L1	Choke 20 μ H		L12861 A
L2	Choke 2 μ H 20%		L12914 A
L3	Choke 2 μ H 20%		L12914 A
L4	Choke 1 μ 5H 5%		L00582 A
L5	Mains Transformer 120-240V (Drg No. L2069-1 A)		L12886 A
-	Mains Transformer 100V (Japan)		L20681 J
-	Mains Transformer 110-220V (Semko)		L21061 S
N1	Circuit Breaker 2A 240V		SP606AA
-	Circuit Breaker 4A 120V		SP606AB
FS1	Fuse 4AT 20mm Delay 240V		UM04ADA
-	Fuse 6.3AT 20mm Delay 120V		UM6A3DA

Q U A D 606 service data

Ref.	Description	Qty	Part No.
FS2	Fuse 6.3AT 20mm Delay		UM6A3DA
SK1	Phono Socket Red Gold Plated		PSPHOG2
-	Phono Socket White Gold Plated		PSPHOG9
SK2	Terminal Post Red 30A (After S/No. 3800)	2	PTPOST2
-	Socket 4mm Red (Before S/No. 3800)	2	PSRS14C
SK3	Terminal Post Black 30A (Before S/No. 3800)	2	PTPOST0
-	Socket 4mm Black (Before S/No. 3800)	2	PSBS14C
SK4	Mains Outlet Socket – Euro Moated	-	PSP695S
PL1	Mains Input Plug/Fuse Holder – Euro	-	PPF333C
1	LED Sub Assembly	-	Q60LEPA
2	Rectifier 'T' Board Sub Assembly	2	Q60REPA
3	Amplifier Sub Assembly C/W Heatsink	2	Q60PCBA
4	Transformer Suspension Kit (For Models before S/No. 3000)		Q60SUSP
S1	Mains On/Off Switch 2600-HM-11 E		S2600 HA

ACCESSORIES

Ref.	Description	Qty	Part No.
1	Speaker Plug Red 4mm	2	PP60912
2	Speaker Plug Black 4mm	2	PP60920
3	Signal Lead 1 m 2 Phono-2 Phono		QP2P21 A
4	Mains Lead 1 m IEC Plug Shrouded-IEC Socket		QSPES1 B
5	Instruction Book (English)		OI601 EC

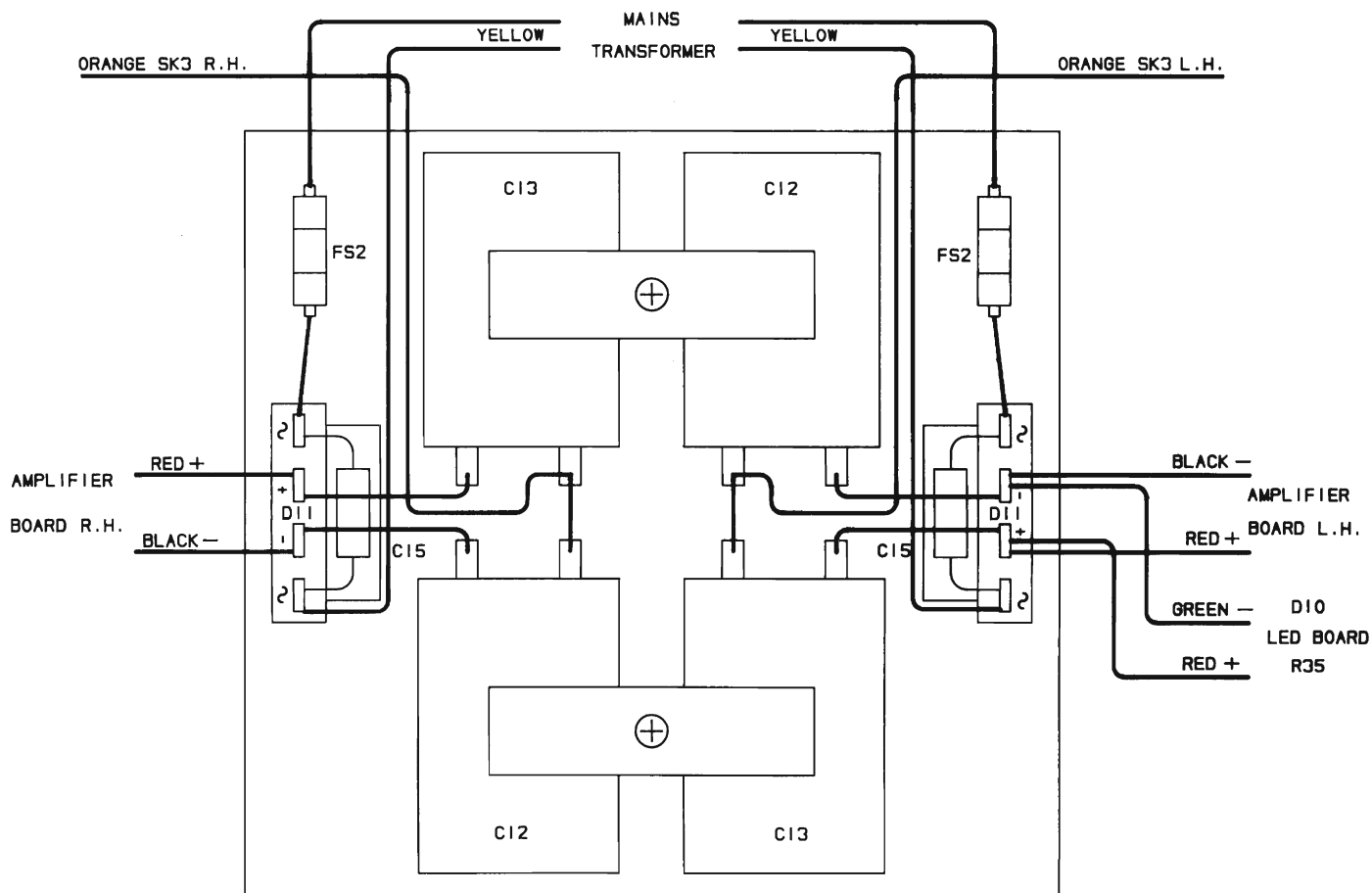

606 Pre Rectifier 'T' Board
 (Before S/No. 1751)
 (Bottom View)

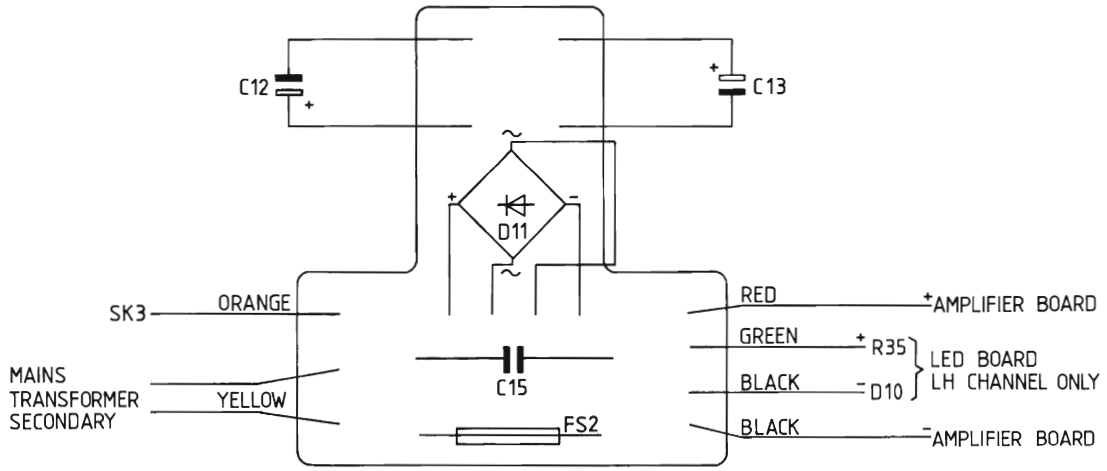

2033-1 T BOARD

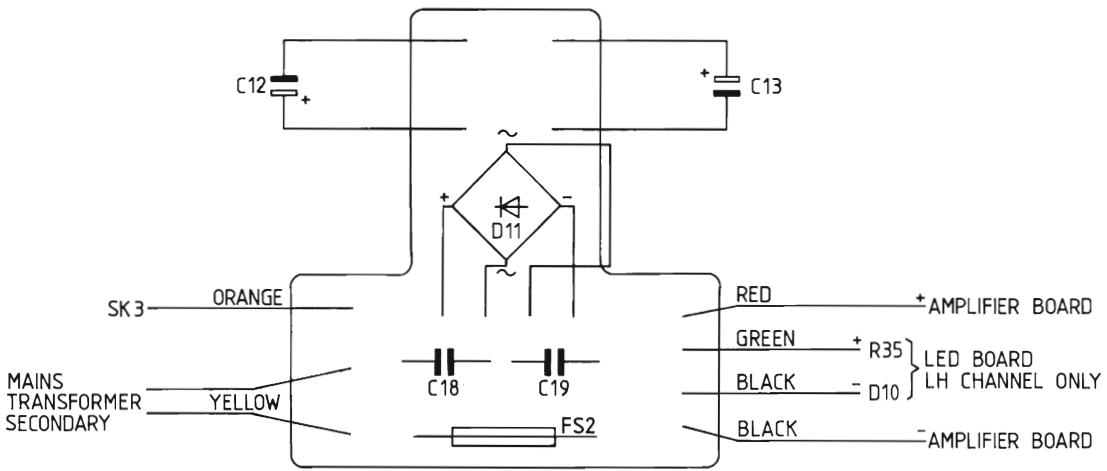

2033-3 T BOARD

WIRING COLOUR CODE
 BN = BROWN
 BL = BLACK
 B = BLUE
 GN = GREEN
 GN/Y = GREEN/YELLOW
 O = ORANGE
 R = RED
 Y = YELLOW
 WH = WHITE
 SCR = SCREEN

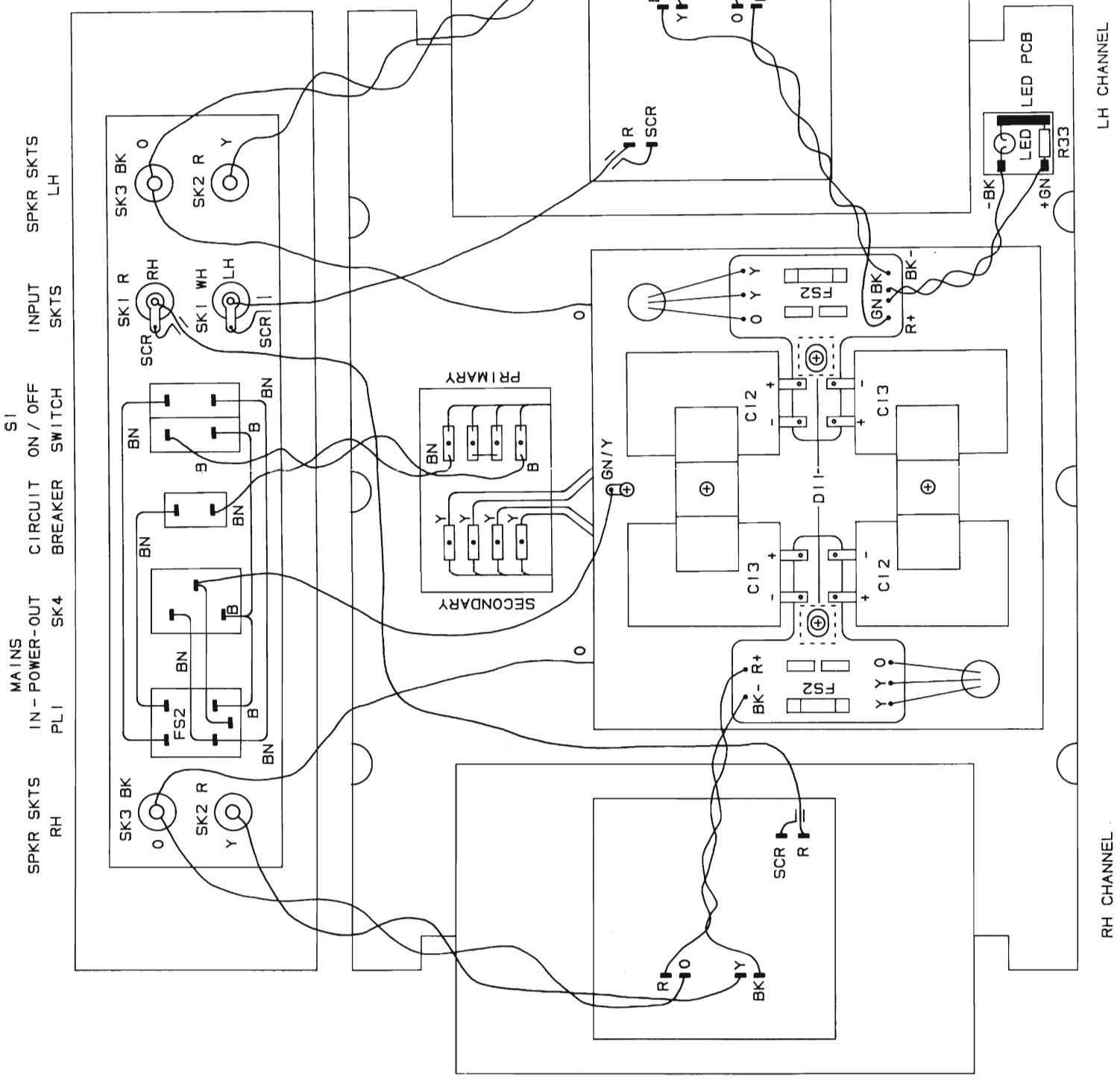

from 0-3200 issue 1
from 3200 till 5700 issue 2

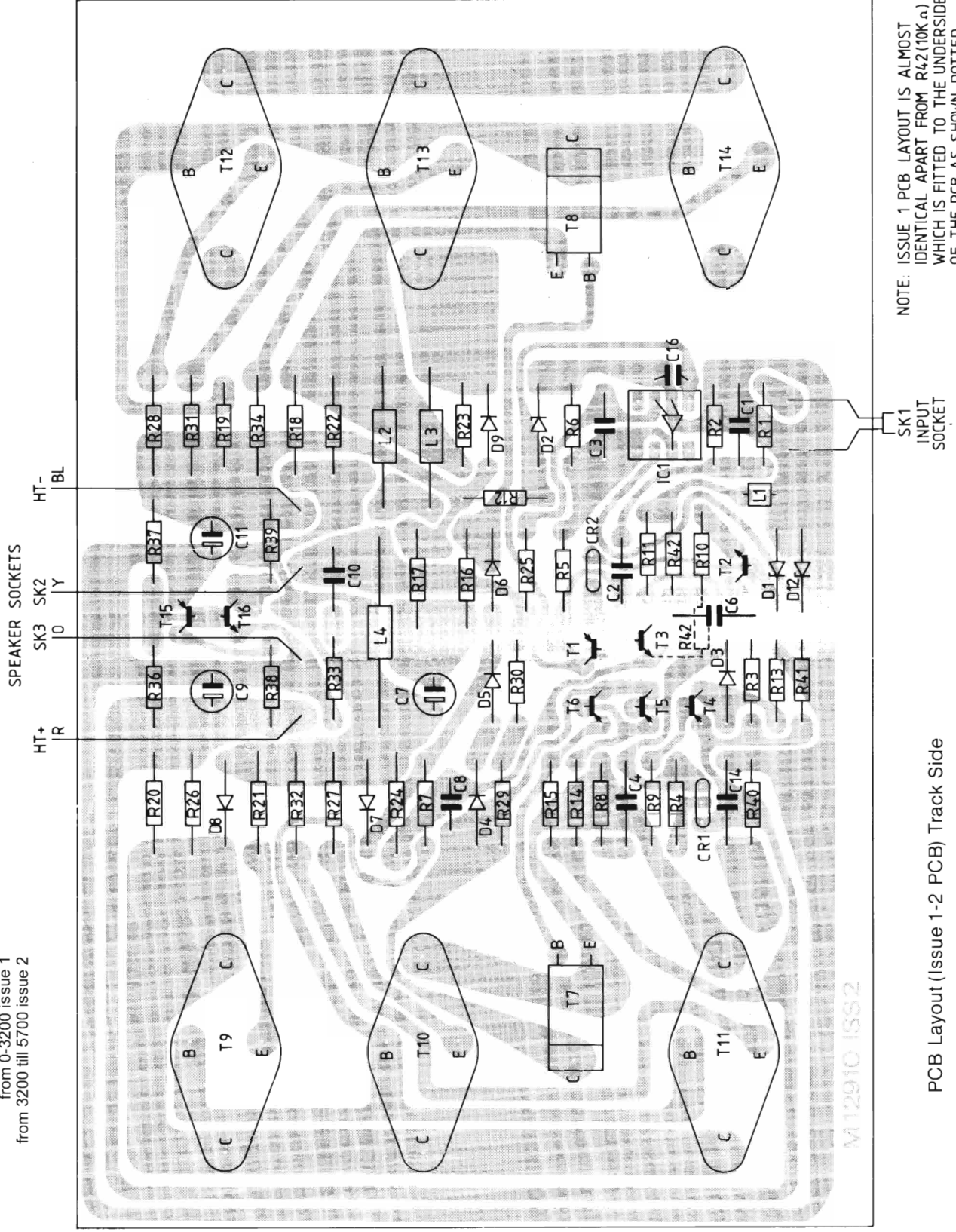

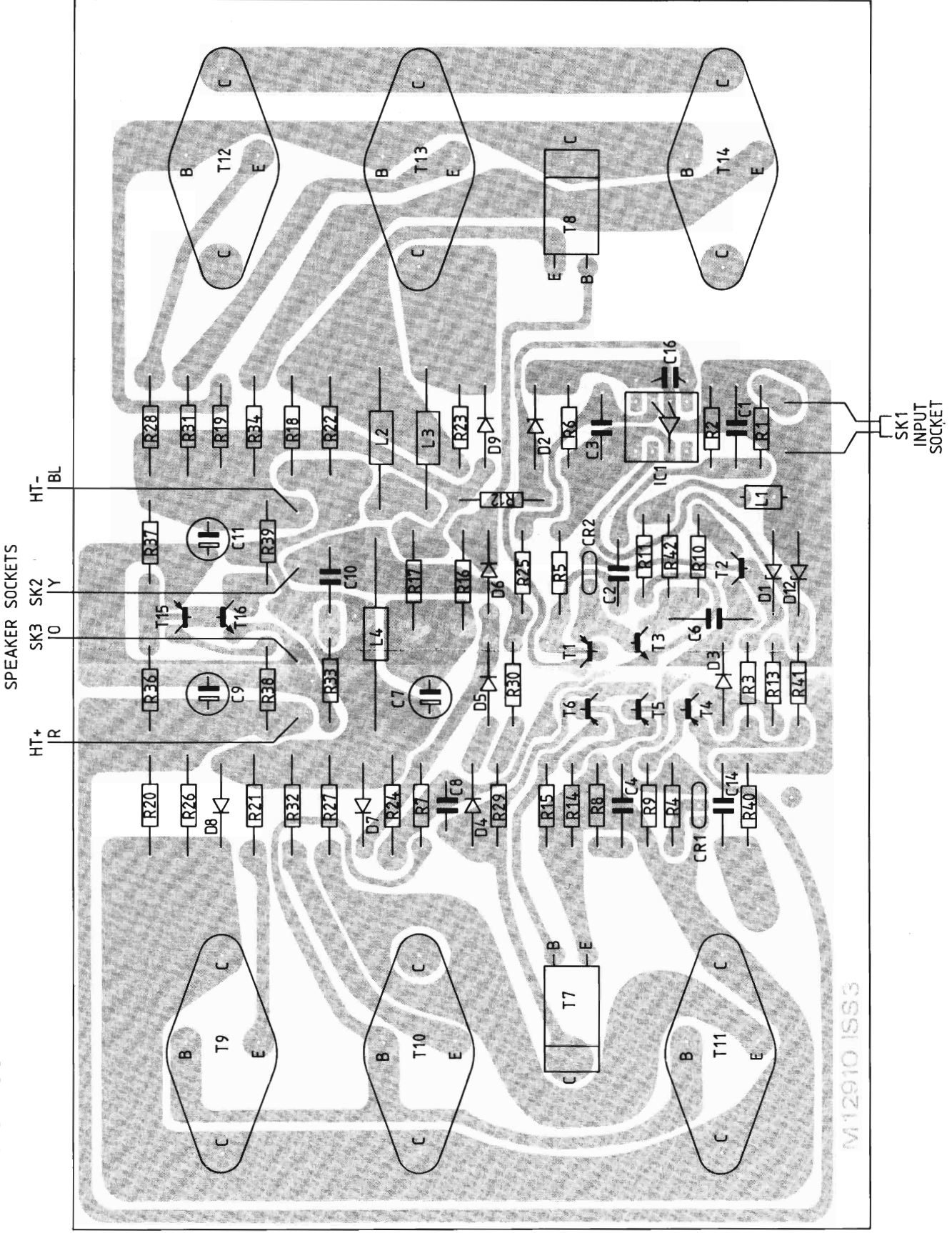

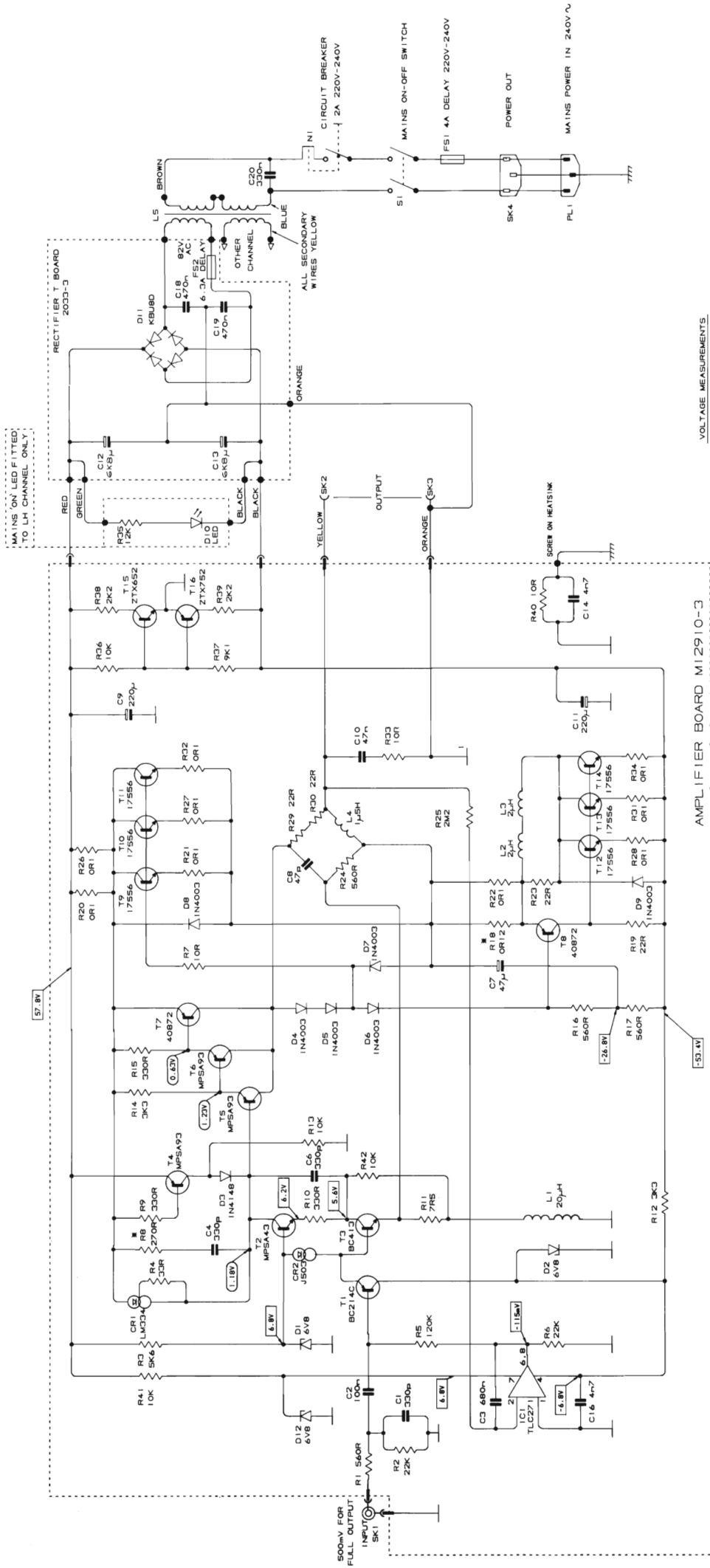

VOLTAGE MEASUREMENTS

- ALL VOLTAGES ARE TYPICAL AND WERE TAKEN WITH A MAINS SUPPLY OF 240V USING A THURLEY 1504 DIGITAL METER. WITH NO INPUT SIGNAL.
- MEASURED USING -VE PROBE WITH RESPECT TO +VE RAIL
- MEASURED USING +VE PROBE WITH RESPECT TO P.C.B. EARTH

■ VALUE SUBJECT TO CHANGE

serial 5700 and onwards Circuit Diagram (Issue 3 PCB)