

Typical Application



QX-EG-530

Audio and Visual Equipment

- Cassette Tape Recorder
- Car Cassette Player

Electronic governor motor

Model	Working Voltage	Rated Voltage	Rated Load		Rated Speed	Rated Load Current	Load Fluctuation (TYP)	Stall Torque
	(V)	(V)	g.cm	mN.m	r.p.m.	mA(TYP)	r.p.m / g.cm	g.cm
QX-EG-530-6F(6B)	4.2-7.5	6.0	8.0	0.78	2400±2%	132	9.0	38 at 4.2V
QX-EG-530-7F(7B)	5.0-9.0	7.5	8.0	0.78	2400±2%	115	9.0	45 at 5.0V
QX-EG-530-9F(9B)	6.0-11.0	9.0	8.0	0.78	2400±2%	92	9.0	50 at 6.0V
QX-EG-530-2F(2B)	8.4-15.0	8.0	8.0	0.78	2400±2%	73	9.0	60 at 8.4V

Dimensions

Unit: mm

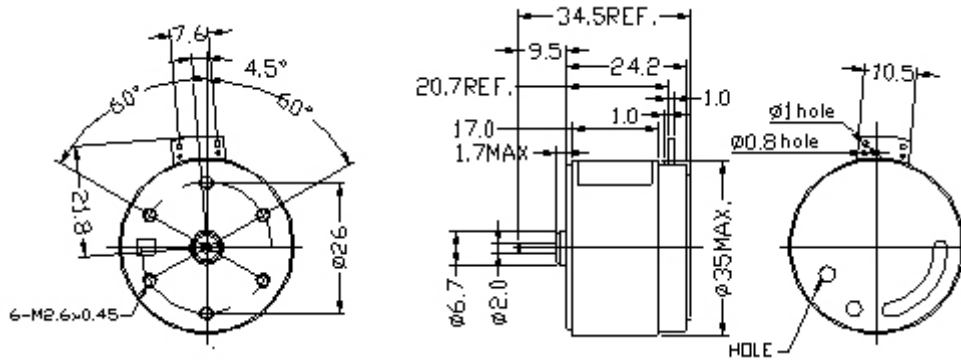

Weight: 70g (Approx)

Characteristic Curve

QX-EG-530KD 8.4V / 12V / 15.6V

