



# 82527 SERIAL COMMUNICATIONS CONTROLLER CONTROLLER AREA NETWORK PROTOCOL

*Automotive*

- **Supports CAN Specification 2.0**
  - Standard Data and Remote Frames
  - Extended Data and Remote Frames
- **Programmable Global Mask**
  - Standard Message Identifier
  - Extended Message Identifier
- **15 Message Objects of 8-Byte Data Length**
  - 14 Tx/Rx Buffers
  - 1 Rx Buffer with Programmable Mask
- **Flexible CPU Interface**
  - 8-Bit Multiplexed
  - 16-Bit Multiplexed
  - 8-Bit Non-Multiplexed (Synchronous/Asynchronous)
  - Serial Interface
- **Programmable Bit Rate**
- **Programmable Clock Output**
- **Flexible Interrupt Structure**
- **Flexible Status Interface**
- **Configurable Output Driver**
- **Configurable Input Comparator**
- **Two 8-Bit Bidirectional I/O Ports**
- **44-Lead PLCC Package**
- **44-Lead QFP Package**
- **Pinout Compatibility with the 82526**

The 82527 serial communications controller is a highly integrated device that performs serial communication according to the CAN protocol. It performs all serial communication functions such as transmission and reception of messages, message filtering, transmit search, and interrupt search with minimal interaction from the host microcontroller, or CPU.

The 82527 is Intel's first device to support the standard and extended message frames in CAN Specification 2.0 Part B. It has the capability to transmit, receive, and perform message filtering on extended message frames. Due to the backwardly compatible nature of CAN Specification 2.0, the 82527 also fully supports the standard message frames in CAN Specification 2.0 Part A.

The 82527 features a powerful CPU interface that offers flexibility to directly interface to many different CPUs. It can be configured to interface with CPUs using an 8-bit multiplexed, 16-bit multiplexed, or 8-bit non-multiplexed address/data bus for Intel and non-Intel architectures. A flexible serial interface (SPI) is also available when a parallel CPU interface is not required.

The 82527 provides storage for 15 message objects of 8-byte data length. Each message object can be configured as either transmit or receive except for the last message object. The last message object is a receive-only buffer with a special mask design to allow select groups of different message identifiers to be received.

The 82527 also implements a global masking feature for message filtering. This feature allows the user to globally mask any identifier bits of the incoming message. The programmable global mask can be used for both standard and extended messages.

The 82527 PLCC offers hardware, or pinout, compatibility with the 82526. It is pin-to-pin compatible with the 82526 except for pins 9, 30, and 44. These pins are used as chip selects on the 82526 and are used as CPU interface mode selection pins on the 82527.

The 82527 is fabricated using Intel's reliable CHMOS III 5V technology and is available in either 44-lead PLCC or 44-lead QFP for the automotive temperature range (–40°C to +125°C).

\*Other brands and names are the property of their respective owners.  
Information in this document is provided in connection with Intel products. Intel assumes no liability whatsoever, including infringement of any patent or copyright, for sale and use of Intel products except as provided in Intel's Terms and Conditions of Sale for such products. Intel retains the right to make changes to these specifications at any time, without notice. Microcomputer Products may have minor variations to this specification known as errata.  
COPYRIGHT © INTEL CORPORATION, 1995

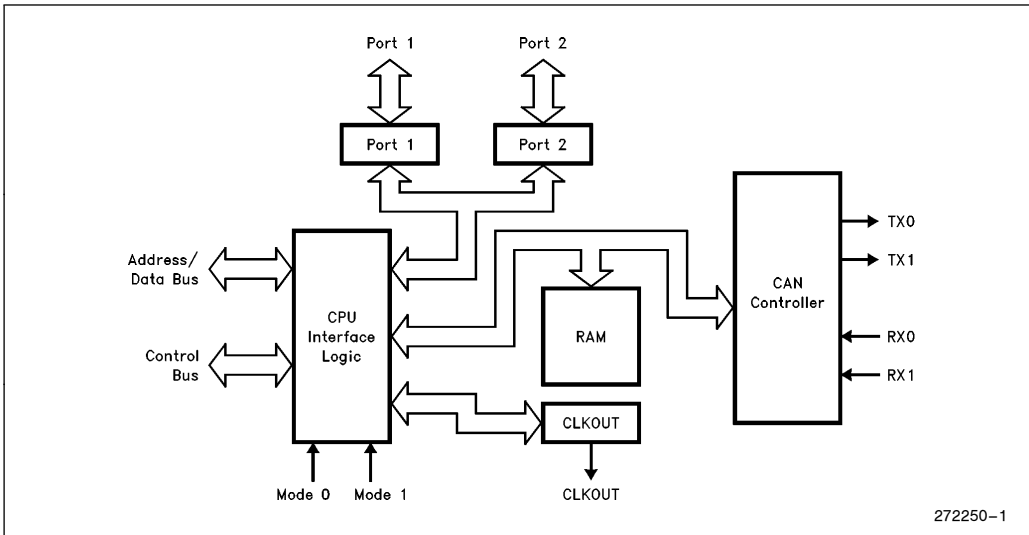

Figure 1. 82527 Block Diagram

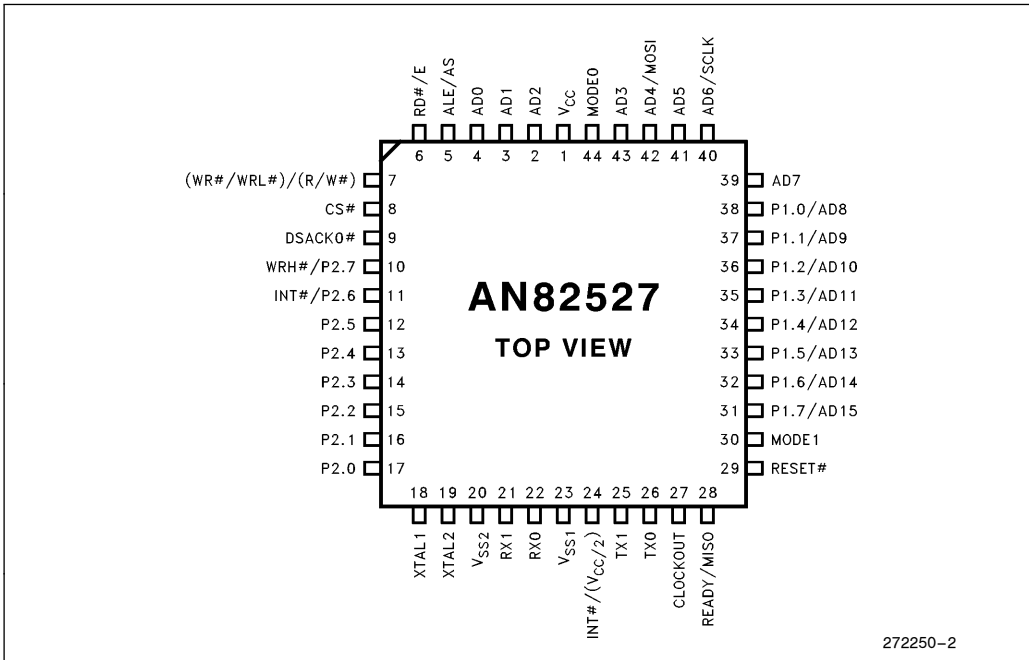

Figure 2. 44-Pin PLCC Package

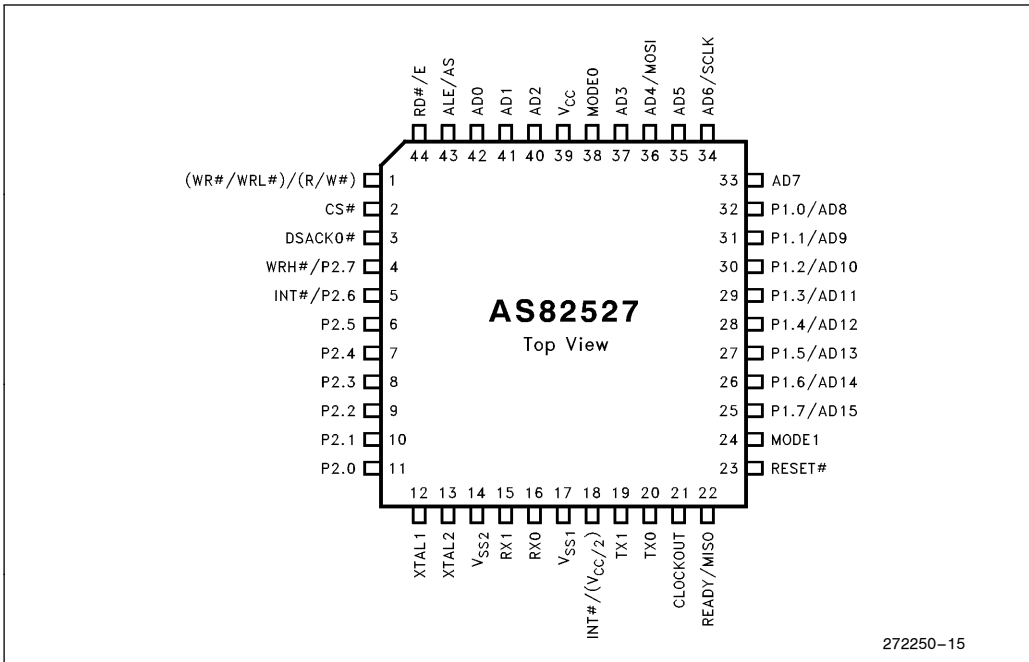

Figure 3. 44-Pin QFP Package

## PIN DESCRIPTION

The 82527 pins are described in this section. Table 1 presents the legend for interpreting the pin types.

**Table 1. Pin Type Legend**

Symbol	Description
I	Input only pin
O	Output only pin
I/O	Pin can be either input or output

## PIN DESCRIPTIONS

Pin Name	Pin Type	Pin Description
V <sub>SS1</sub>	Ground	GROUND connection must be connected externally to a V <sub>SS</sub> board plane. Provides digital ground.
V <sub>SS2</sub>	Ground	GROUND connection must be connected externally to a V <sub>SS</sub> board plane. Provides ground for analog comparator.
V <sub>CC</sub>	Power	POWER connection must be connected externally to +5V DC. Provides power for entire device.
XTAL1	I	Input for an external clock. XTAL1 (along with XTAL2) are the crystal connections to an internal oscillator.
XTAL2	O	Push-pull output from the internal oscillator. XTAL2 (along with XTAL1) are the crystal connections to an internal oscillator. If an external oscillator is used XTAL2 must be floated, or not be connected. XTAL2 must not be used as a clock output to drive other CPUs.
CLKOUT	O	Programmable clock output. This output may be used to drive the oscillator of the host microcontroller.
RESET #	I	Warm Reset: (V <sub>CC</sub> remains valid while RESET # is asserted), RESET # must be driven to a valid low level for 1 ms minimum. Cold Reset: (V <sub>CC</sub> is driven to a valid level while RESET # is asserted), RESET # must be driven low for 1 ms minimum measured from a valid V <sub>CC</sub> level. No falling edge on the reset pin is required during a cold reset event.
CS #	I	A low level on this pin enables CPU access to the 82527 device.
INT # (V <sub>CC</sub> /2)	O O	The interrupt pin is an open-drain output to the host microcontroller. V <sub>CC</sub> /2 is the power supply for the ISO low speed physical layer. The function of this pin is determined by the MUX bit in the CPU Interface Register (Address 02H) as follows: MUX = 1: pin 24 (PLCC) = V <sub>CC</sub> /2, pin 11 = INT # MUX = 0: pin 24 (PLCC) = INT #
RX0 RX1	I I	Inputs from the CAN bus line(s) to the input comparator. A recessive level is read when RX0 > RX1. A dominant level is read when RX1 > RX0. When the CoBy bit (Bus Configuration register) is programmed as a "1", the input comparator is bypassed and RX0 is the CAN bus line input.
TX0 TX1	O O	Serial data push-pull output to the CAN bus line. During a recessive bit TX0 is high and TX1 is low. During a dominant bit TX0 is low and TX1 is high.

Pin Name	Pin Type	Pin Description
AD0/A0/ICP AD1/A1/CP AD2/A2/CSAS AD3/A3/STE AD4/A4/MOSI AD5/A5 AD6/A6/SCLK AD7/A7	I/O-I-I I/O-I-I I/O-I-I I/O-I I/O-I-I I/O-I I/O-I-I I/O-I	Address/Data bus in 8-bit multiplexed mode. Address bus in 8-bit non-multiplexed mode. Low byte of A/D bus in 16-bit multiplexed mode. In Serial Interface mode, the following pins have the following meaning: AD0: ICP Idle Clock Polarity AD1: CP Clock Phase AD2: CSAS Chip Select Active State AD3: STE Sync Transmit Enable AD6: SCLK Serial Clock Input AD4: MOSI Serial Data Input
AD8/D0/P1.0 AD9/D1/P1.1 AD10/D2/P1.2 AD11/D3/P1.3 AD12/D4/P1.4 AD13/D5/P1.5 AD14/D6/P1.6 AD15/D7/P1.7	I/O-O-I/O I/O-O-I/O I/O-O-I/O I/O-O-I/O I/O-O-I/O I/O-O-I/O I/O-O-I/O I/O-O-I/O	High byte of A/D bus in 16-bit multiplexed mode. Data bus in 8-bit non-multiplexed mode. Low speed I/O port. P1 pins in 8-bit multiplexed mode and serial mode. Port pins have weak pullups until the port is configured by writing to 9FH and AFH.
P2.0 P2.1 P2.2 P2.3 P2.4 P2.5 P2.6/INT # P2.7/WRH #	I/O I/O I/O I/O I/O I/O I/O-O I/O-I	P2 in all modes. P2.6 is INT # when MUX = 1 and is open-drain. P2.7 is WRH # in 16-bit multiplexed mode.
Mode0 Mode1	I I	These pins select one of the four parallel interfaces. These pins are weakly held low during reset. <b>Mode1 Mode0</b> 0 0 8-bit multiplexed — Intel 0 0 Serial Interface mode entered when RD# = 0, WR# = 0 upon reset. 0 1 16-bit multiplexed — Intel 1 0 8-bit multiplexed — non-Intel 1 1 8-bit non-multiplexed
ALE/AS	I-I	ALE used for Intel modes. AS used for non-Intel modes, except Mode 3 this pin must be tied high.
RD # E	I I	RD # used for Intel modes. E used for non-Intel modes, except Mode 3 Asynchronous this pin must be tied high.
WR # /WRL # R/W #	I I	WR # in 8-bit Intel mode and WRL # in 16-bit Intel mode. R/W # used for non-Intel modes.
READY MISO	O O	READY is an output to synchronize accesses from the host microcontroller to the 82527. READY is an open-drain output to the host microcontroller. MISO is the serial data output for the serial interface mode.
DSACK0 #	O	DSACK0 # is an open-drain output to synchronize accesses from the host microcontroller to the 82527.

## ELECTRICAL CHARACTERISTICS

### ABSOLUTE MAXIMUM RATINGS\*

Storage Temperature .....  $-60^{\circ}\text{C}$  to  $+150^{\circ}\text{C}$   
 Voltage from Any Pin  
 to  $V_{SS}$  .....  $-0.5\text{V}$  to  $+7.0\text{V}$

Laboratory testing shows the 82527 will withstand up to 10 mA of injected current into both RX0 and RX1 pins for a total of 20 days without sustaining permanent damage. This high current condition may be the result of shorted signal lines. The 82527 will not function properly if the RX0/RX1 input voltage exceeds  $V_{CC} + 0.5\text{V}$ .

NOTICE: This is a production data sheet. The specifications are subject to change without notice.

*\*WARNING: Stressing the device beyond the "Absolute Maximum Ratings" may cause permanent damage. These are stress ratings only. Operation beyond the "Operating Conditions" is not recommended and extended exposure beyond the "Operating Conditions" may affect device reliability.*

### D.C. Characteristics $V_{CC} = 5\text{V} \pm 10\%$ ; $T_A = -40^{\circ}\text{C}$ to $+125^{\circ}\text{C}$

Symbol	Parameter	Min	Max	Conditions
$V_{IL}$	Input Low Voltage (All except RX0, RX1, AD0–AD7 in Mode 3)	$-0.5\text{V}$	0.8V	
$V_{IL1}$	Input Low Voltage for AD0–AD7 in Mode 3	$-0.5\text{V}$	0.5V	
$V_{IL2}$	Input Low Voltage (RX0) for Comparator Bypass Mode		0.5V	
$V_{IL3}$	Input Low Voltage for Port 1 and Port 2 Pins Not Used for Interface to Host CPU		$0.3 V_{CC}$	
$V_{IH}$	Input High Voltage (All except RX0, RX1, RESET #)	3.0V	$V_{CC} + 0.5\text{V}$	
$V_{IH1}$	Input High Voltage (RESET #) Hysteresis on RESET #	3.0V 200 mV	$V_{CC} + 0.5\text{V}$	
$V_{IH2}$	Input High Voltage (RX0) for Comparator Bypass Mode	4.0V		
$V_{IH3}$	Input High Voltage for Port 1 and Port 2 Pins Not Used for Interface to Host CPU	$0.7 V_{CC}$		
$V_{OL}$	Output Low Voltage (All Outputs except TX0, TX1)		0.45V	$I_{OL} = 1.6\text{ mA}$
$V_{OH}$	Output High Voltage (All Outputs except TX0, TX1, CLOCKOUT)	$V_{CC} - 0.8\text{V}$		$I_{OH} = -200\text{ }\mu\text{A}$
$V_{OHR1}$	Output High Voltage (CLOCKOUT)	$0.8 V_{CC}$		$I_{OH} = -80\text{ }\mu\text{A}$
$I_{LK}$	Input Leakage Current		$\pm 10\text{ }\mu\text{A}$	$V_{SS} < V_{IN} < V_{CC}$
$C_{IN}$	PIN Capacitance**		10 pF	$f_{XTAL} = 1\text{ KHz}$

**D.C. Characteristics**  $V_{CC} = 5V \pm 10\%$ ;  $T_A = -40^\circ\text{C}$  to  $+125^\circ\text{C}$ 

Symbol	Parameter	Min	Max	Conditions
$I_{CC}$	Supply Current <sup>(1)</sup>		50 mA	$f_{XTAL} = 16\text{ MHz}$
$I_{SLEEP}$	Sleep Current <sup>(1)</sup> with $V_{CC}/2$ Output Enabled, No Load with $V_{CC}/2$ Output Disabled		700 $\mu\text{A}$ 100 $\mu\text{A}$	
$I_{PD}$	Powerdown Current <sup>(1)</sup>		25 $\mu\text{A}$	XTAL1 Clocked

**NOTES:**

\*\*Typical value based on characterization data.

Port pins are weakly held after reset until the port configuration registers are written (9FH, AFH).

1. All pins are driven to  $V_{SS}$  or  $V_{CC}$  including RX0 and RX1.

**PHYSICAL LAYER SPECIFICATIONS** Load Condition: 100 pF

**D.C. Characteristics**  $V_{CC} = 5V \pm 10\%$ ;  $T_A = -40^\circ\text{C}$  to  $+125^\circ\text{C}$ 

RX0/RX1 and TX0/TX1	Min	Max	Conditions
Input Voltage	-0.5V	$V_{CC} + 0.5V$	
Common Mode Range	$V_{SS} + 1V$	$V_{CC} - 1V$	
Differential Input Threshold	$\pm 100\text{ mV}$		
Internal Delay 1: Sum of the Comparator Input Delay and the TX0/TX1 Output Driver Delay		60 ns	Load on TX0, TX1 = 100 pF, +100 mV to -100 mV RX0/RX1 differential
Internal Delay 2: Sum of the RX0 Pin Delay (if the Comparator is Bypassed) and the TX0/TX1 Output Driver Delay		50 ns	Load on TX0, TX1 = 100 pF
Source Current on Each TX0, TX1		-10 mA	$V_{OUT} = V_{CC} - 1.0V$
Sink Current on Each TX0, TX1		10 mA	$V_{OUT} = 1.0V$
Input Hysteresis for RX0/RX1		0V	
<b><math>V_{CC}/2</math></b>			
$V_{CC}/2$	2.38V	2.62V	$I_{OUT} \leq 75\ \mu\text{A}$ , $V_{CC} = 5V$

**CLOCKOUT SPECIFICATIONS**

Load Condition: 50 pF

Parameter	Min	Max
CLOCKOUT Frequency	XTAL/15	XTAL

### A.C. Characteristics for 8/16-Bit Multiplexed Intel Modes (Modes 0, 1)

Conditions:  $V_{CC} = 5V \pm 10\%$ ,  $V_{SS} = 0V$ ,  $T_A = -40^\circ C$  to  $+125^\circ C$ ,  $C_L = 100$  pF

Symbol	Parameter	Min	Max	Conditions
$1/t_{XTAL}$	Oscillator Frequency	8 MHz	16 MHz	
$1/t_{SCLK}$	System Clock Frequency	4 MHz	10 MHz	
$1/t_{MCLK}$	Memory Clock Frequency	2 MHz	8 MHz	
$t_{AVLL}$	Address Valid to ALE Low	7.5 ns		
$t_{LLAX}$	Address Hold after ALE Low	10 ns		
$t_{LHLL}$	ALE High Time	30 ns		
$t_{LLRL}$	ALE Low to RD# Low	20 ns		
$t_{CLLL}$	CS# Low to ALE Low	10 ns		
$t_{QVWH}$	Data Setup to WR# High	27 ns		
$t_{WHQX}$	Input Data Hold after WR# High	10 ns		
$t_{WLWH}$	WR# Pulse Width	30 ns		
$t_{WHLH}$	WR# High to Next ALE High	8 ns		
$t_{WHCH}$	WR# High to CS# High	0 ns		
$t_{RLRH}$	RD# Pulse Width This time is long enough to initiate a double read cycle by loading the High Speed Registers (04H, 05H), but is too short to READ from 04H and 05H (See $t_{RLDV}$ )	40 ns		
$t_{RLDV}$	RD# Low to Data Valid (Only for Registers 02H, 04H, 05H)	0 ns	55 ns	
$t_{RLDV1}$	RD# Low Data to Data Valid (for Registers except 02H, 04H, 05H) for Read Cycle without a Previous Write <sup>(1)</sup> for Read Cycle with a Previous Write <sup>(1)</sup>		$1.5 t_{MCLK} + 100$ ns $3.5 t_{MCLK} + 100$ ns	
$t_{RHDZ}$	Data Float after RD# High	0 ns	45 ns	
$t_{CLYV}$	CS# Low to READY Setup Condition: Load Capacitance on the READY Output: 50 pF		32 ns 40 ns	$V_{OL} = 1.0V$ $V_{OL} = 0.45V$
$t_{WLYZ}$	WR# Low to READY Float for a Write Cycle if No Previous Write is Pending <sup>(2)</sup>		145 ns	
$t_{WHYZ}$	End of Last Write to READY Float for a Write Cycle if a Previous Write Cycle is Active <sup>(2)</sup>		$2 t_{MCLK} + 100$ ns	
$t_{RLYZ}$	RD# Low to READY Float (for registers except 02H, 04H, 05H) for Read Cycle without a Previous Write <sup>(1)</sup> for Read Cycle with a Previous Write <sup>(1)</sup>		$2 t_{MCLK} + 100$ ns $4 t_{MCLK} + 100$ ns	



**A.C. Characteristics for 8/16-Bit Multiplexed Intel Modes (Modes 0, 1)**

Conditions:  $V_{CC} = 5V \pm 10\%$ ,  $V_{SS} = 0V$ ,  $T_A = -40^{\circ}C$  to  $+125^{\circ}C$ ,  $C_L = 100$  pF (Continued)

Symbol	Parameter	Min	Max	Conditions
$t_{WHDV}$	WR# High to Output Data Valid on Port 1/2	$t_{MCLK}$	$2 t_{MCLK} + 500$ ns	
$t_{COPO}$	CLKOUT Period	$(CD_V + 1) * t_{OSC}^{(3)}$		
$t_{CHCL}$	CLKOUT High Period	$(CD_V + 1) * \frac{1}{2} t_{OSC} - 10$	$(CD_V + 1) * \frac{1}{2} t_{OSC} + 15$	

**NOTES:**

References to WR# also pertain to WRH#.

1. Definition of "read cycle without a previous write": The time between the rising edge of WR# /WRH# (for the previous write cycle) and the falling edge of RD# (for the current read cycle) is greater than  $2 t_{MCLK}$ .
2. Definition of "write cycle with a previous write": The time between the rising edge of WR# /WRH# (for the previous write cycle) and the rising edge of WR# /WRH# (for the current write cycle) is less than  $2 t_{MCLK}$ .
3. Definition of  $CD_V$  is the value loaded in the CLKOUT register representing the CLKOUT divisor.

**A.C. Characteristics for 8/16-Bit Multiplexed Intel Modes (Modes 0, 1)**

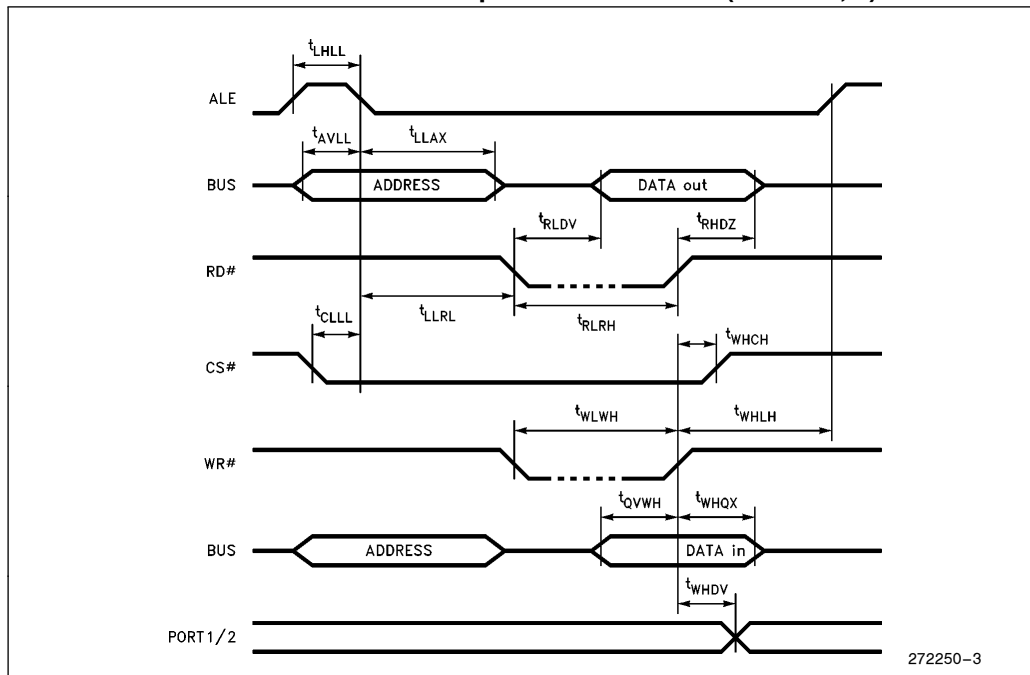

272250-3

**A.C. Characteristics for 8/16-Bit Multiplexed Intel Modes (Modes 0, 1)**

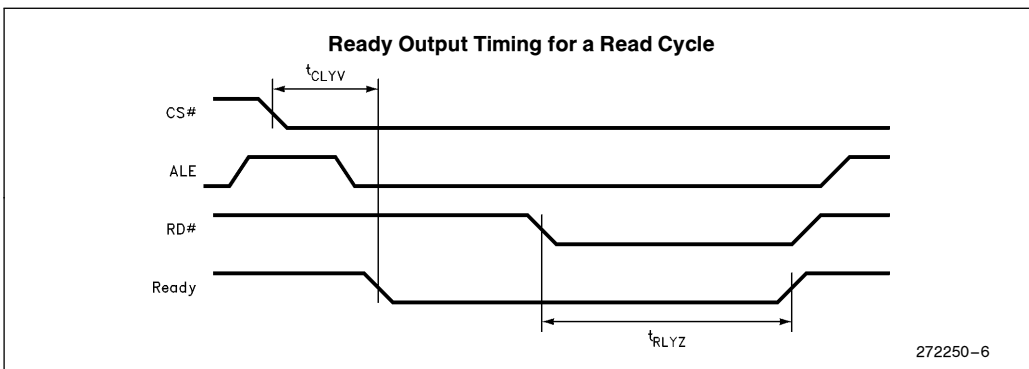
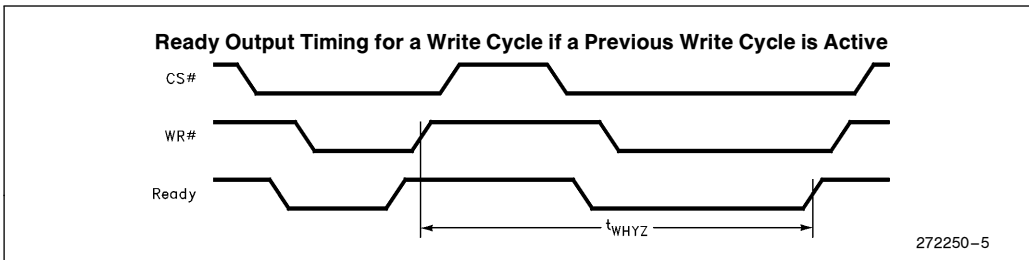
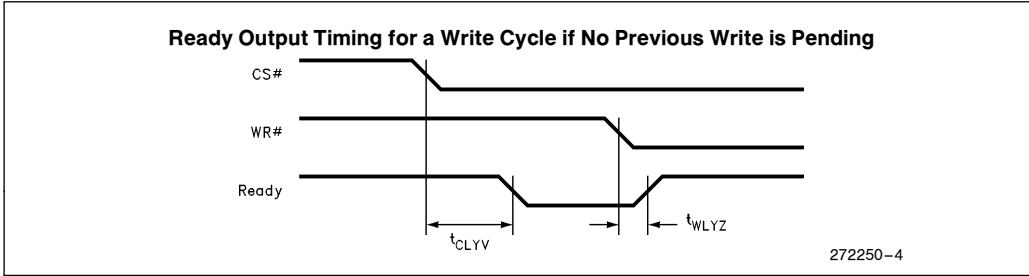

### A.C. Characteristics for 8-Bit Multiplexed Non-Intel Mode (Mode 2)

Conditions:  $V_{CC} = 5V \pm 10\%$ ,  $V_{SS} = 0V$ ,  $T_A = -40^\circ C$  to  $+125^\circ C$ ,  $C_L = 100$  pF

Symbol	Parameter	Min	Max
$1/t_{XTAL}$	Oscillator Frequency	8 MHz	16 MHz
$1/t_{SCLK}$	System Clock Frequency	4 MHz	10 MHz
$1/t_{MCLK}$	Memory Clock Frequency	2 MHz	8 MHz
$t_{AVSL}$	Address Valid to AS Low	7.5 ns	
$t_{SLAX}$	Address Hold after AS Low	10 ns	
$t_{ELDZ}$	Data Float after E Low	0 ns	45 ns
$t_{EHDV}$	E High to Data Valid for Registers 02H, 04H, 05H	0 ns	45 ns
	for Read Cycle without a Previous Write <sup>(1)</sup> for Read Cycle with a Previous Write (for Registers except for 02H, 04H, 05H)		1.5 $t_{MCLK} + 100$ ns 3.5 $t_{MCLK} + 100$ ns
$t_{QVEL}$	Data Setup to E Low	30 ns	
$t_{ELQX}$	Input Data Hold after E Low	20 ns	
$t_{ELDV}$	E Low to Output Data Valid on Port 1/2	$t_{MCLK}$	$2 t_{MCLK} + 500$ ns
$t_{EHEL}$	E High Time	45 ns	
$t_{ELEL}$	End of Previous Write (Last E Low) to E Low for a Write Cycle	$2 t_{MCLK}$	
$t_{SHSL}$	AS High Time	30 ns	
$t_{RSEH}$	Setup Time of R/W# to E High	30 ns	
$t_{SLEH}$	AS Low to E High	20 ns	
$t_{CLSL}$	CS# Low to AS Low	20 ns	
$t_{ELCH}$	E Low to CS# High	0 ns	
$t_{COPD}$	CLKOUT Period	$(CD_V + 1) * t_{OSC}^{(3)}$	
$t_{CHCL}$	CLKOUT High Period	$(CD_V + 1) * \frac{1}{2} t_{OSC} - 10$	$(CD_V + 1) * \frac{1}{2} t_{OSC} + 15$

#### NOTES:

1. Definition of "Read Cycle without a Previous Write": The time between the falling edge of E (for the previous write cycle) and the rising edge of E (for the current read cycle) is greater than  $2 t_{MCLK}$ .
2. Definition of "Write Cycle with a Previous Write": The time between the falling edge of E (for the previous write cycle) and the falling edge of E (for the current write cycle) is less than  $2 t_{MCLK}$ .
3. Definition of  $CD_V$  is the value loaded in the CLKOUT register representing the CLKOUT divisor.

**A.C. Characteristics for 8-Bit Multiplexed Non-Intel Mode (Mode 2)**

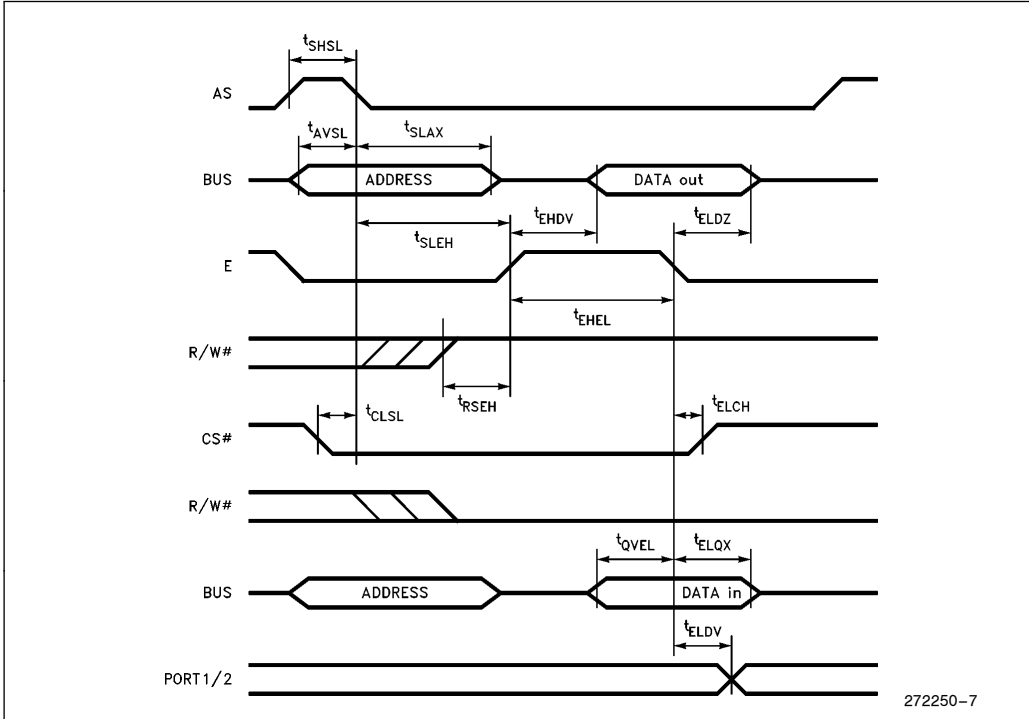

**A.C. Characteristics for 8-Bit Non-Multiplexed Asynchronous (Mode 3)**

 Conditions:  $V_{CC} = 5V \pm 10\%$ ,  $V_{SS} = 0V$ ,  $T_A = -40^\circ C$  to  $+125^\circ C$ ,  $C_L = 100$  pF

Symbol	Parameter	Min	Max
$1/t_{XTAL}$	Oscillator Frequency	8 MHz	16 MHz
$1/t_{SCLK}$	System Clock Frequency	4 MHz	10 MHz
$1/t_{MCLK}$	Memory Clock Frequency	2 MHz	8 MHz
$t_{AVCL}$	Address or R/W# Valid to CS# Low Setup	3 ns	
$t_{CLDV}$	CS# Low to Data Valid for High Speed Registers (02H, 04H, 05H)	0 ns	55 ns
	For Low Speed Registers (Read Cycle without Previous Write) <sup>(1)</sup>	0 ns	$1.5 t_{MCLK} + 100$ ns
	For Low Speed Registers (Read Cycle with Previous Write) <sup>(1)</sup>	0 ns	$3.5 t_{MCLK} + 100$ ns
$t_{KLDV}$	DSACK0# Low to Output Data Valid for High Speed Read Register		23 ns
	For Low Speed Read Register	< 0 ns	
$t_{CHDV}$	82527 Input Data Hold after CS# High	15 ns	
$t_{CHDH}$	82527 Output Data Hold after CS# High	0 ns	
$t_{CHDZ}$	CS# High to Output Data Float		35 ns
$t_{CHKH_1}$	CS# High to DSACK0# = 2.4V <sup>(3)</sup>	0 ns	55 ns
$t_{CHKH_2}$	CS# High to DSACK0# = 2.8V		150 ns
$t_{CHKZ}$	CS# High to DSACK0# Float	0 ns	100 ns
$t_{CHCL}$	CS# Width between Successive Cycles	25 ns	
$t_{CHAI}$	CS# High to Address Invalid	7 ns	
$t_{CHRI}$	CS# High to R/W# Invalid	5 ns	
$t_{CLCH}$	CS# Width Low	65 ns	
$t_{DVCH}$	CPU Write Data Valid to CS# High	20 ns	
$t_{CLKL}$	CS# Low to DSACK0# Low for High Speed Registers and Low Speed Registers Write Access without Previous Write <sup>(2)</sup>	0 ns	67 ns
$t_{CHKL}$	End of Previous Write (CS# High) to DSACK0# Low for a Write Cycle with a Previous Write <sup>(2)</sup>	0 ns	$2 t_{MCLK} + 145$ ns
$t_{COPD}$	CLKOUT Period	$(CD_V + 1) * t_{OSC}^{(4)}$	
$t_{CHCL}$	CLKOUT High Period	$(CD_V + 1) * \frac{1}{2} t_{OSC} - 10$	$(CD_V + 1) * \frac{1}{2} t_{OSC} + 15$

**NOTES:**

E and AS must be tied high in this mode.

 1. Definition of "Read Cycle without a Previous Write": The time between the rising edge of CS# (for the previous write cycle) and the falling edge of CS# (for the current read cycle) is greater than  $2 t_{MCLK}$ .

 2. Definition of "Write Cycle without a Previous Write": The time between the rising edge of CS# (for the previous write cycle) and the rising edge of CS# (for the current write cycle) is greater than  $2 t_{MCLK}$ .

3. An on-chip pullup will drive DSACK0# to approximately 2.4V. An external pullup is required to drive this signal to a higher voltage.

 4. Definition of  $CD_V$  is the value loaded in the CLKOUT register representing the CLKOUT divisor.

**A.C. Characteristics for 8-Bit Non-Multiplexed Asynchronous Mode (Mode 3)**

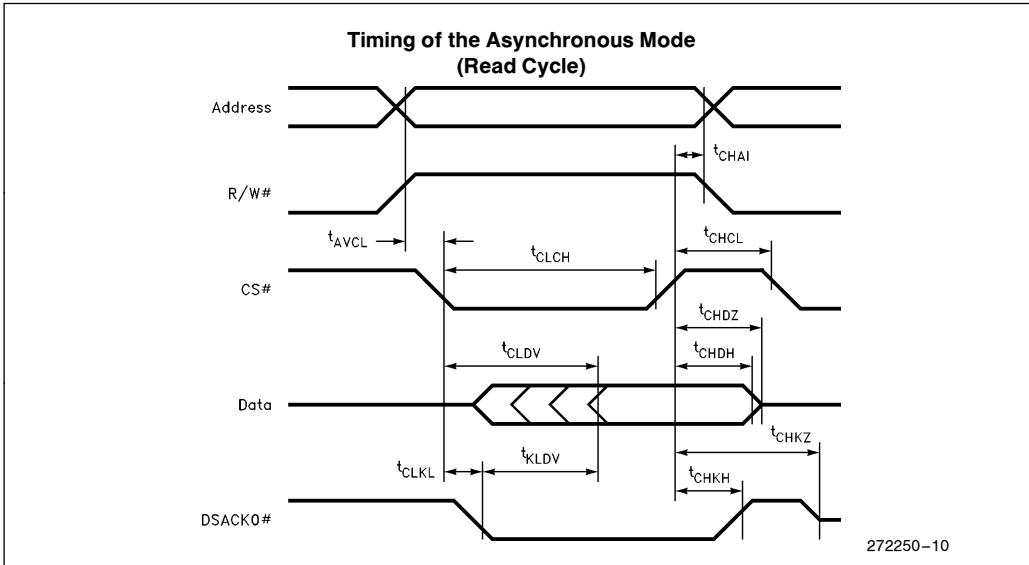

**A.C. Characteristics for 8-Bit Non-Multiplexed Asynchronous Mode (Mode 3)**

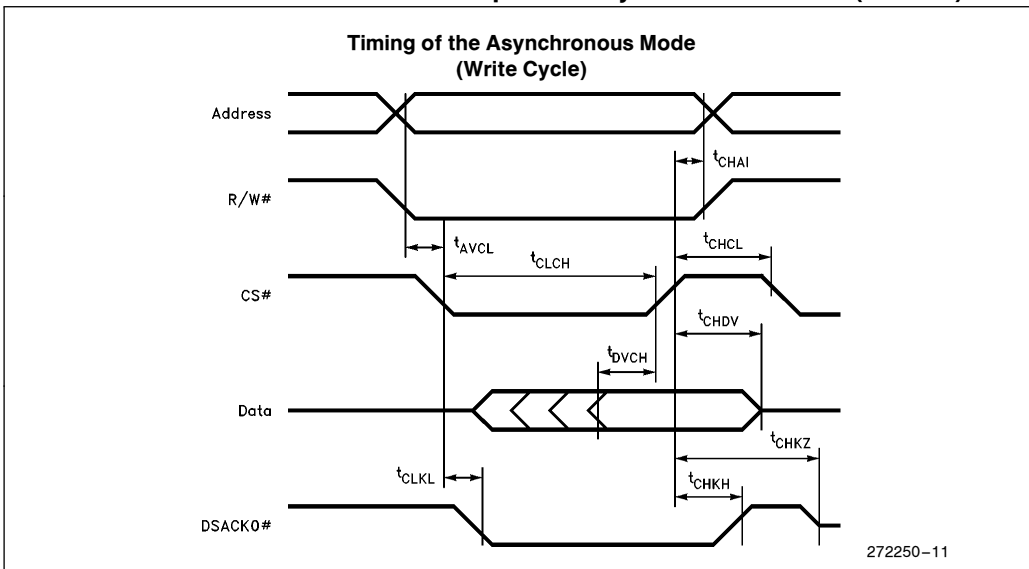

### A.C. Characteristics for 8-Bit Non-Multiplexed Synchronous Mode (Mode 3)

Conditions:  $V_{CC} = 5V \pm 10\%$ ,  $V_{SS} = 0V$ ,  $T_A = -40^\circ C$  to  $+125^\circ C$ ,  $C_L = 100$  pF

Symbol	Parameter	Min	Max
$1/t_{XTAL}$	Oscillator Frequency	8 MHz	16 MHz
$1/t_{SCLK}$	System Clock Frequency	4 MHz	10 MHz
$1/t_{MCLK}$	Memory Clock Frequency	2 MHz	8 MHz
$t_{EHDV}$	E High to Data Valid out of High Speed Register (02H, 04H, 05H)		55 ns
	Read Cycle without Previous Write for Low Speed Registers <sup>(1)</sup>		$1.5 t_{MCLK} + 100$ ns
	Read Cycle with Previous Write for Low Speed Registers <sup>(1)</sup>		$3.5 t_{MCLK} + 100$ ns
$t_{ELDH}$	Data Hold after E Low for a Read Cycle	5 ns	
$t_{ELDZ}$	Data Float after E Low		35 ns
$t_{ELDV}$	Data Hold after E Low for a Write Cycle	15 ns	
$t_{AVEH}$	Address and R/W# to E Setup	25 ns	
$t_{ELAV}$	Address and R/W# Valid after E Falls	15 ns	
$t_{CVEH}$	CS# Valid to E High	0 ns	
$t_{ELCV}$	CS# Valid after E Low	0 ns	
$t_{DVEL}$	Data Setup to E Low	55 ns	
$t_{EHEL}$	E Active Width	100 ns	
$t_{AVAV}$	Start of a Write Cycle after a Previous Write Access	$2 t_{MCLK}$	
$t_{AVCL}$	Address or R/W# to CS# Low Setup	3 ns	
$t_{CHAI}$	CS# High to Address Invalid	7 ns	
$t_{COPD}$	CLKOUT Period	$(CD_V + 1) * t_{OSC}^{(2)}$	
$t_{CHCL}$	CLKOUT High Period	$(CD_V + 1) * \frac{1}{2} t_{OSC} - 10$	$(CD_V + 1) * \frac{1}{2} t_{OSC} + 15$

#### NOTES:

- Definition of "Read Cycle without a Previous Write": The time between the falling edge of E (for the previous write cycle) and the rising edge of E (for the current read cycle) is greater than  $2 t_{MCLK}$ .
- Definition of  $CD_V$  is the value loaded in the CLKOUT register representing the CLKOUT divisor.

**A.C. Characteristics for 8-Bit Non-Multiplexed Synchronous Mode (Mode 3)**

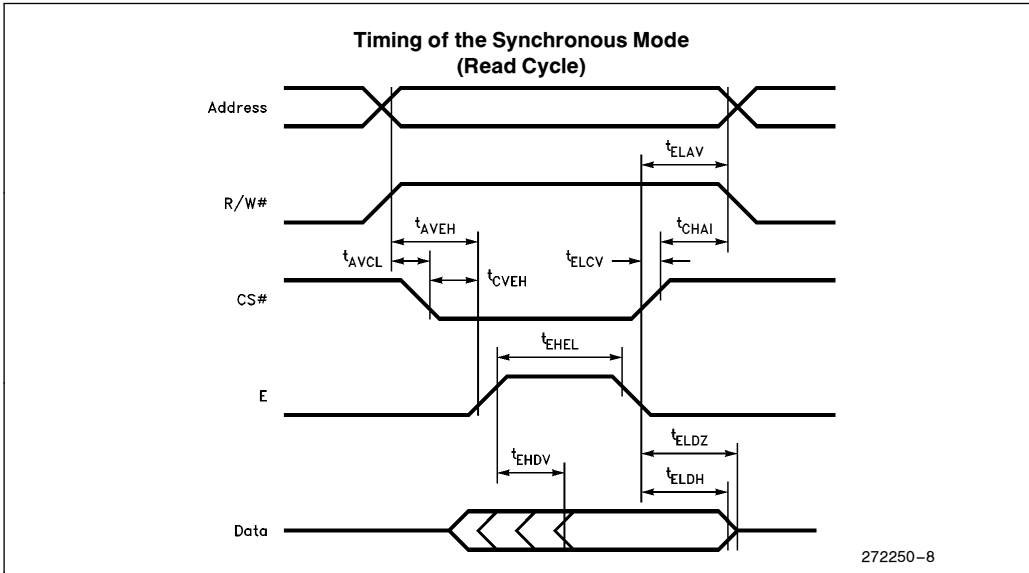

**A.C. Characteristics for 8-Bit Non-Multiplexed Synchronous Mode (Mode 3)**

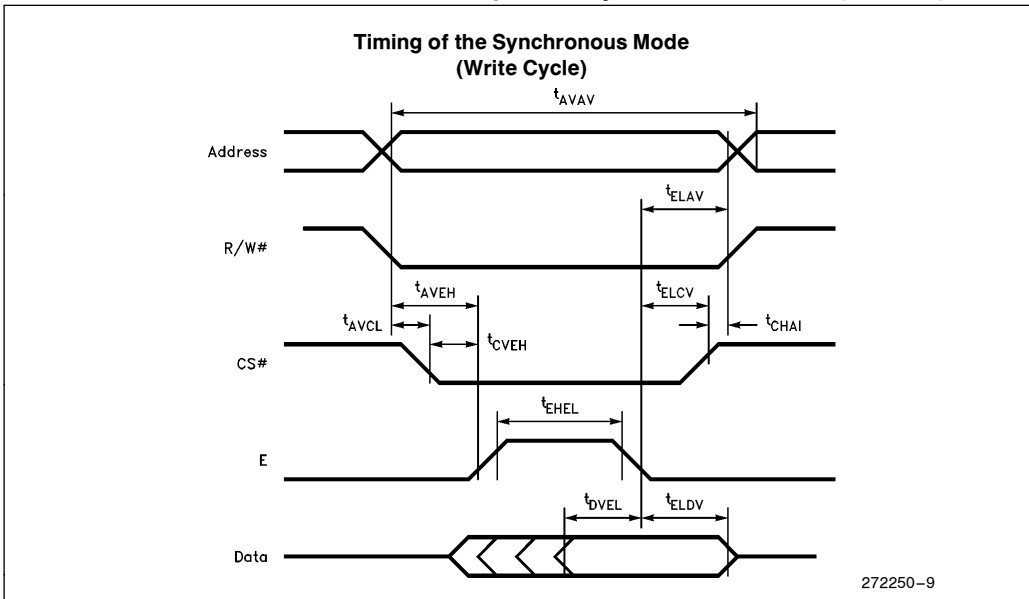



### A.C. Characteristics for Serial Interface Mode

Conditions:  $V_{CC} = 5V \pm 10\%$ ,  $V_{SS} = 0V$ ,  $T_A = -40^\circ C$  to  $+125^\circ C$ ,  $C_L = 100$  pF

Symbol	Parameter	Min	Max
SCLK	SPI Clock	0.5 MHz	8 MHz
$t_{CYC}$	1/SCLK	125 ns	2000 ns
$t_{SKHI}$	Minimum Clock High Time	84 ns	
$t_{SKLO}$	Minimum Clock Low Time	84 ns	
$t_{LEAD}$	ENABLE Lead Time	70 ns	
$t_{LAG}$	Enable Lag Time	109 ns	
$t_{ACC}$	Access Time		60 ns
$t_{PDO}$	Maximum Data Out Delay Time		59 ns
$t_{HO}$	Minimum Data Out Hold Time	0 ns	
$t_{DIS}$	Maximum Data Out Disable Time		665 ns
$t_{SETUP}$	Minimum Data Setup Time	35 ns	
$t_{HOLD}$	Minimum Data Hold Time	84 ns	
$t_{RISE}$	Maximum Time for Input to go from $V_{OL}$ to $V_{OH}$		100 ns
$t_{FALL}$	Maximum Time for Input to go from $V_{OH}$ to $V_{OL}$		100 ns
$t_{CS}$	Minimum Time between Consecutive CS# Assertions	670 ns	
$t_{COPD}$	CLKOUT Period	$(CD_V + 1) * t_{OSC}^{(1)}$	
$t_{CHCL}$	CLKOUT High Period	$(CD_V + 1) * \frac{1}{2} t_{OSC} - 10$	$(CD_V + 1) * \frac{1}{2} t_{OSC} + 15$

**NOTE:**

1. Definition of  $CD_V$  is the value loaded in the CLKOUT register representing the CLKOUT divisor.

**A.C. Characteristics for Serial Interface Mode**

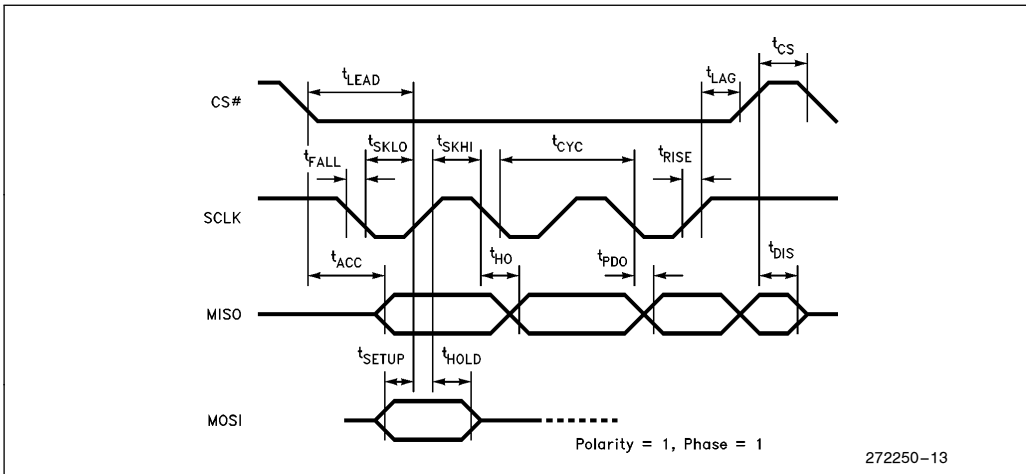
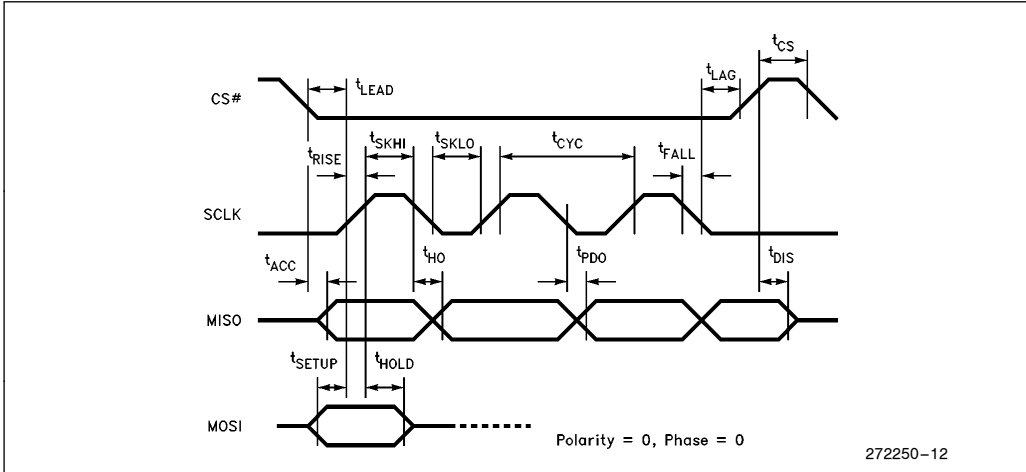

**A.C. TESTING INPUT**

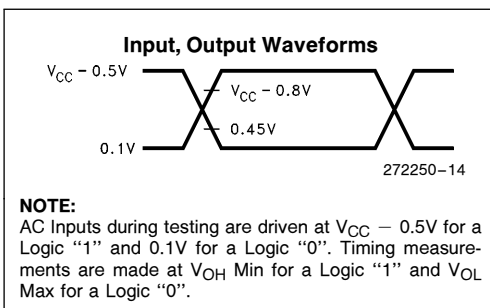

**DATA SHEET REVISION HISTORY**

This is the -006 revision of the 82527 data sheet. The following differences exist between the -005 version and the -006 revision. There were no specification changes between the -004 version and the -005 revision.

1. The 82527 44-ld QFP was added to the product description, the pinmap for the QFP package is also included.
2. The pin numbers were removed from the pin description list to accommodate the new 44-ld QFP package.



3. Removed XTAL1 and XTAL2 from the exceptions for  $V_{IL}$  spec. XTAL1  $V_{IL}$  is now specified at min = -0.5V, max = 0.8V. XTAL2 is an output.
4. Removed XTAL1 and XTAL2 from the exceptions for  $V_{IH}$  spec. XTAL1  $V_{IH}$  is now specified at min = 3.0V, max =  $V_{CC} + 0.5V$ . XTAL2 is an output.
5. Source and Sink current for TX0 and TX1 were corrected from minimum values to maximum values.
6. Mode 2; The  $t_{AVSL}$  specification was decreased to 7.5 ns from 33 ns.
7. Mode 2; The  $t_{SLAX}$  specification was decreased to 10 ns from 20 ns.
8. Mode 3, Asynchronous; The  $t_{DVCH}$  specification was decreased to 20 ns from 32 ns.
9. All modes; Two specifications were added for CLKOUT. These specifications are  $t_{COPD}$  (CLKOUT Period) =  $(CD_V + 1) * t_{OSC}$ , and  $t_{CHCL}$  (CLKOUT High Period) =  $\min(CD_V + 1) * \frac{1}{2} t_{OSC} - 10 \text{ ns}$  and  $\max(CD_V + 1) * \frac{1}{2} t_{OSC} + 15 \text{ ns}$ . **NOTE:**  $CD_V$  represented the value loaded in the lower nibble of the CLKOUT Register (1FH).
10. Serial Interface Mode; The maximum SCLK (SPI Clock) rate was increased to 8 MHz from 4.2 MHz. The minimum  $t_{CYC}$  (1/SCLK) was set at 125 ns from 238 ns to reflect the increased maximum SPI clock rate.
11. MODE0/1, the  $t_{WHQX}$  Specifications was decreased to 10 ns from 12.5 ns.

This is the -004 revision of the 82527 data sheet. The following differences exist between the -003 version and the -004 revision.

1. Remove notice on page 1 concerning Advance Information Data Sheet.
2. Page 4, AS pin description, add "pin tied high in Asynchronous mode 3".
3. Page 4, E pin description, add "pin tied high in mode 3".
4. Page 5, add  $V_{IH} = 0.7 V_{CC}$  and  $V_{IL} = 0.3 V_{CC}$  for LSIO port pins (pins not used to interface to host-CPU).
5. Page 6, change Differential Input Threshold from MAX spec to MIN spec.
6. Page 6, add Input Hysteresis spec for RX0/RX1 = 0V maximum.
7. Page 7,  $t_{LLAX}$  decreased from 20 ns to 10 ns (to interface to 20 MHz C196).
8. Page 7,  $t_{QVWH}$  decreased from 30 ns to 27 ns (to interface to 20 MHz C196).
9. Page 7,  $t_{WLWH}$  decreased from 40 ns to 30 ns (to interface to 20 MHz C196).
10. Page 7,  $t_{RLDV}$  increased from 45 ns to 55 ns.
11. Page 12,  $t_{CHKH}$  specification added for  $V_{IH} = 2.8V = 150 \text{ ns}$ .
12. Page 12,  $t_{CHAI}$  decreased from 10 ns to 7 ns.
13. Page 13, timing diagram for  $t_{AVCL}$  revised to show common CL low level.
14. Page 14,  $t_{CHAI}$  decreased from 10 ns to 7 ns.

15. Page 7,  $t_{CLLL}$  decreased from 20 ns to 10 ns.
  16. Page 3, RESET# description addition:  
 Warm reset: ( $V_{CC}$  remains valid while RESET# is asserted), RESET# must be driven to a valid low level for 1 ms minimum.  
 Cold reset: ( $V_{CC}$  is driven to a valid level while RESET# is asserted, RESET# must be driven low for 1 ms minimum measured from a valid  $V_{CC}$  level. No falling edge on the reset pin is required during a cold reset event.
  17. Page 2, Figure 2: Pin 7 name changed to (WR#/WRL#)/(R/W#) from WR#/(R/W#).
  18. Page 4, pin description name changed to (WR#/WRL#)/(R/W#) from WR#/(R/W#) and WR# in 8-bit Intel mode and WRL# in 16-bit Intel mode replaces the description WR# used for Intel modes.
  19. Page 5, ABSOLUTE MAXIMUM RATINGS addition: Laboratory testing shows the 82527 will withstand up to 10 mA for injected current into both RX0 and RX1 pins for a total of 20 days without sustaining permanent damage. This high current condition may be the result of shorted signal lines. The 82527 will not function properly if the RX0/RX1 input voltage exceeds  $V_{CC} + 0.5V$ .
  20. Page 12,  $t_{CHDV}$  decreased from 25 ns to 15 ns.
  21. Page 14,  $t_{ELDV}$  decreased from 25 ns to 15 ns.
  22. Page 7,  $t_{AVLL}$  decreased from 20 ns to 7.5 ns.
  23. Page 7,  $t_{WHQX}$  decreased from 20 ns to 12.5 ns.
- This is the -003 revision of the 82527 data sheet. The following differences exist between the -002 version and the -003 revision.
1. The data sheet has been revised to ADVANCE from PRELIMINARY, indicating the specifications have been verified through electrical tests.
  2. ABSOLUTE MAXIMUM RATINGS have been added.
  3.  $V_{IL}$  no longer applies to the AD0–AD7 pins in CPU Interface mode 3.
  4.  $V_{IL1}$  has been added to specify Input Low Voltage for AD0–AD7 pins in CPU Interface mode 3 as  $-0.5V$  minimum and  $+0.5V$  maximum.
  5.  $I_{CC}$  supply current has been reduced to 50 mA from 100 mA.
  6. Note 2 was added stating during  $I_{PD}$  testing, all pins are driven to  $V_{SS}$  or  $V_{CC}$ , including RX0 and RX1.
  7.  $t_{AVLL}$  has been decreased to 20 ns from 33 ns.
  8.  $t_{RLDV1}$  has been decreased to  $1.5 t_{MCLK} + 100$  ns from  $2 t_{MCLK} + 100$  ns for a Read Cycle without a previous Write (Modes 0, 1).  
 $t_{RLDV1}$  has been decreased to  $3.5 t_{MCLK} + 100$  ns from  $4 t_{MCLK} + 100$  ns for a Read Cycle with a previous Write (Modes 0, 1).
  9.  $t_{CLYV}$  has added the condition of  $V_{OL} = 1.0V$  for a 32 ns delay.  $t_{CLYV}$  is 40 ns for  $V_{OL} = 0.45$  (Modes 0, 1).
  10.  $t_{WHYZ}$  has been decreased to  $2 t_{MCLK} + 100$  ns from  $2 t_{MCLK} + 145$  ns (Modes 0, 1).
  11.  $t_{EHDV}$  has been decreased to  $1.5 t_{MCLK} + 100$  ns from  $2 t_{MCLK} + 100$  ns for a Read Cycle without a previous Write (Mode 2).  
 $t_{EHDV}$  has been decreased to  $3.5 t_{MCLK} + 100$  ns from  $4 t_{MCLK} + 100$  ns for a Read Cycle with a previous Write (Mode 2).
  12.  $t_{EEL}$  has been decreased to  $2 t_{MCLK}$  from  $2 t_{MCLK} + 145$  ns (Mode 2).
  13.  $t_{CLDV}$  has been decreased to 55 ns from 65 ns (Mode 3).
  14.  $t_{CHKH}$  is specified for  $V_{IH} = 2.4V$ , decreased from  $V_{IH} = 3.0V$ . Note 3 has been added which states an on-chip pullup will drive DSACK0# to approximately 2.4V. An external pullup is required to drive this signal to a higher voltage (Mode 3).
  15.  $t_{CHAI}$  has been increased to 10 ns from 5 ns.  $t_{CHAI}$  no longer includes CS# High to R/W# Invalid (Mode 3).
  16.  $t_{CHRI} = 5$  ns has been added to specify CS# High to R/W# Invalid (Mode 3).
  17.  $t_{EHDV}$  has been decreased to 55 ns from 65 ns for Reads of the High Speed Registers (Mode 3).
  18.  $t_{EHDV}$  has been decreased to  $1.5 t_{MCLK} + 100$  ns from  $2 t_{MCLK} + 100$  ns for a Read Cycle without a previous Write (Mode 3).  
 $t_{EHDV}$  has been decreased to  $3.5 t_{MCLK} + 100$  ns from  $4 t_{MCLK} + 100$  ns for a Read Cycle with a previous Write (Mode 3).
  19. The  $t_{AVAV}$  specification name has been corrected to  $t_{AVAV}$  (Mode 3).
  20.  $t_{CHAI}$  has been increased to 10 ns from 5 ns (Mode 3).
  21. The input voltage in the A.C. Testing Input Diagram have been revised to  $V_{CC} - 0.5V$  from 3.0V (high level) and revised to 0.1V from 0.8V (low level).

The following differences exist between the -001 version and the -002 revision.

1. The RAM block in Figure 1. 82527 Block Diagram was previously called DPRAM.
2. The INT #/(V<sub>CC</sub>/2) pin in Figure 2. 44-Pin PLCC Package and in other descriptions was previously called the INT #/(V<sub>DD</sub>/2) pin.
3. The Mode0 and Mode1 pin descriptions were modified to include the following note: These pins are weakly held low during reset.
4. The DSACK0# pin description was changed to reflect an open-drain output.
5. V<sub>IL1</sub> for RX0 in comparator bypass mode was added.
6. V<sub>IH1</sub> hysteresis on RESET# was added.
7. V<sub>IH2</sub> for RX0 in comparator bypass mode was added.
8. I<sub>SLEEP</sub> current with V<sub>CC</sub>/2 output enabled was corrected from 700 μA minimum to 700 μA maximum.
9. I<sub>SLEEP</sub> current with V<sub>CC</sub>/2 output disabled was corrected from 100 μA minimum to 100 μA maximum.
10. I<sub>PD</sub> current was changed from 10 μA minimum to 25 μA maximum.
11. The following note was added to the electrical characteristics: Port pins are weakly held high after reset until the port configuration registers are written (9FH, AFH).
12. The following D.C. Characteristics Specifications have been removed and replaced by the Internal Delay 1 and Internal Delay 2 specifications. These specifications reflect the production test methodology which requires these two delays to be tested together.
  - a. Delay Dominant to Recessive
  - b. Delay Recessive to Dominant
  - c. Input Delay with Comparator Bypassed
  - d. Rise Time
  - e. Fall Time
13. The following A.C. Characteristics for 8-Bit/16-Bit Multiplexed Intel Modes (Modes 0,1) have been changed:
  - a. 1/t<sub>MCLK</sub> has been increased to 8 MHz from 5 MHz.
  - b. t<sub>LLAX</sub> has been decreased to 20 ns from 22.5 ns.
  - c. t<sub>LLRL</sub> has been increased to 20 ns from 0 ns.
  - d. t<sub>CLLL</sub> has been added.
  - e. t<sub>WHLH</sub> has been increased to 8 ns from 0 ns.
  - f. t<sub>WHCH</sub> has been added.
  - g. t<sub>RLDV1</sub> has been added.
  - h. t<sub>WLYH</sub> has been changed to t<sub>WLYZ</sub> to reflect the READY pin is an open-drain output.
  - i. t<sub>WHYH</sub> has been changed to t<sub>WHYZ</sub> to reflect the READY pin is an open-drain output.
  - j. t<sub>RLYH</sub> has been changed to t<sub>RLYZ</sub> to reflect the READY pin is an open-drain output.
  - k. t<sub>WHDV</sub> has been increased to 2 t<sub>MCLK</sub> + 250 ns from 2 t<sub>MCLK</sub> + 100 ns.
  - l. The following note was added: References to WR# also pertain to WRH#.
  - m. The following definition was added for a “read cycle without a previous write”: The time between the rising edge of WR#/WRH# (for the previous write cycle) and the falling edge of RD# (for the current read cycle) is greater than 2 t<sub>MCLK</sub>.
  - n. The following definition was added for a “write cycle with a previous write”: The time between the rising edge of WR#/WRH# (for the previous write cycle) and the next rising edge of WR#/WRH# (for the current write cycle) is less than 2 t<sub>MCLK</sub>.

14. The timing diagrams for 8-Bit/16-Bit Multiplexed Intel Modes (Modes 0,1) have been changed to show ALE rising before CS# falls.
15. The following A.C. Characteristics for 8-Bit Multiplexed Non-Intel Modes (Modes 2) have been changed:
  - a.  $1/t_{MCLK}$  has been increased to 8 MHz from 5 MHz.
  - b.  $t_{SLAX}$  has been decreased to 20 ns from 22.5 ns.
  - c.  $t_{EVDV}$  has been decreased to  $(2, 4) t_{MCLK} + 100$  ns from  $(2, 4) t_{MCLK} + 145$  ns.
  - d.  $t_{ELDV}$  minimum has been decreased to  $t_{MCLK}$  from  $t_{MCLK} + 100$  ns.
  - e.  $t_{ELDV}$  maximum has been increased to  $2 t_{MCLK} + 500$  ns from  $2 t_{MCLK} + 100$  ns.
  - f.  $t_{EHEL}$  for registers except 02H, 04H, 05H has been renamed to  $t_{ELEL}$  and the specification has been decreased to  $2 t_{MCLK} + 145$  ns from  $4 t_{MCLK} + 145$  ns.
  - g.  $t_{SLEH}$  has been increased to 20 ns from 0 ns.
  - h.  $t_{CLSL}$  has been added.
  - i.  $t_{ELCH}$  has been added.
  - j. The following definition was added for a “read cycle without a previous write”: The time between the falling edge of E (for the previous write cycle) and the rising edge of E (for the current read cycle) is greater than  $2 t_{MCLK}$ .
  - k. The following definition was added for a “write cycle with a previous write”: The time between the falling edge of E (for the previous write cycle) and the next falling edge of E (for the current write cycle) is less than  $2 t_{MCLK}$ .
16. The following A.C. Characteristics for 8-Bit Non-Multiplexed Asynchronous Mode (Mode 3) have been changed:
  - a.  $1/t_{MCLK}$  has been increased to 8 MHz from 5 MHz.
  - b.  $t_{CLDV}$  has been decreased for low speed registers to  $(2, 4) t_{MCLK} + 100$  ns from  $(2, 4) t_{MCLK} + 145$  ns.
  - c.  $t_{CHKH}$  comment “with 3.3 K $\Omega$  Pullup and 100 pF Load” has been removed since  $t_{CHKH}$  is tested with a current source.
  - d.  $t_{CLKL}$  for a Write Access with a Previous Write has been renamed to  $t_{CHKL}$ .
  - e. The note “E and AS must be tied high in this mode” has been added.
  - f. The following definition was added for a “read cycle without a previous write”: The time between the rising edge of CS# (for the previous write cycle) and the falling edge of CS# (for the current read cycle) is greater than  $2 t_{MCLK}$ .
  - g. The following definition was added for a “write cycle with a previous write”: The time between the rising edge of CS# (for the previous write cycle) and the next rising edge of CS# (for the current write cycle) is less than  $2 t_{MCLK}$ .
17. The following A.C. Characteristics for 8-Bit Non-Multiplexed Synchronous Mode (Mode 3) have been changed:
  - a.  $1/t_{MCLK}$  has been increased to 8 MHz from 5 MHz.
  - b.  $t_{ELDZ}$  minimum has been removed.
  - c.  $t_{AVCL}$  has been added.
  - d.  $t_{CHAI}$  has been added.
  - e. The following definition was added for a “read cycle without a previous write”: The time between the falling edge of E (for the previous write cycle) and the rising edge of E (for the current read cycle) is greater than  $2 t_{MCLK}$ .
  - f. The following definition was added for a “write cycle with a previous write”: The time between the falling edge of E (for the previous write cycle) and the next falling edge of E (for the current write cycle) is less than  $2 t_{MCLK}$ .
18. The following A.C. Characteristics for Serial Interface Mode have been changed:
  - a.  $t_{SKHI}$  has been decreased to 84 ns from 119 ns.
  - b.  $t_{SKLO}$  has been decreased to 84 ns from 119 ns.
  - c.  $t_{PDO}$  has been decreased to 59 ns from 84 ns.
  - d.  $t_{SETUP}$  has been decreased to 35 ns from 59 ns.
  - e.  $t_{HOLD}$  has been decreased to 84 ns from 109 ns.
19. The note in the A.C. Testing Input diagram referenced  $V_{OH}$  was previously named  $V_{IH}$ .