

R 1 2 7 5 N S 2 1 H

**- Power Thyristor
2100 V_{DRM};**

HIGH POWER THYRISTOR FOR INVERTER AND CHOPPER APPLICATIONS

Features:

- . All Diffused Structure
- . Interdigitated Amplifying Gate Configuration
- . Blocking capability up to 2100 volts
- . Guaranteed Maximum Turn-Off Time
- . High dV/dt Capability
- . Pressure Assembled Device

ELECTRICAL CHARACTERISTICS AND RATINGS

Blocking - Off State

Device Type	V _{RRM} (1)	V _{DRM} (1)	V _{RSM} (1)
R1275NS21H	2100	2100	2200

- V_{RRM} = Repetitive peak reverse voltage
- V_{DRM} = Repetitive peak off state voltage
- V_{RSM} = Non repetitive peak reverse voltage (2)

Repetitive peak reverse leakage and off state leakage	I _{RRM} /I _{DRM}	150 mA
Critical rate of voltage rise	dV/dt (4)	200 V/μsec

Notes:

- All ratings are specified for T_j=25 °C unless otherwise stated.
- (1) All voltage ratings are specified for an applied 50Hz/60Hz sinusoidal waveform over the temperature range -40 to +125 °C.
 - (2) 10 msec. max. pulse width
 - (3) Maximum value for T_j = 125 °C.
 - (4) Minimum value for linear and exponential waveshape to 80% rated V_{DRM}. Gate open. T_j = 125 °C.
 - (5) Non-repetitive value.
 - (6) The value of di/dt is established in accordance with EIA/NIMA Standard RS-397, Section 5-2-2-6. The value defined would be in addition to that obtained from a snubber circuit, comprising a 0.2 μF capacitor and 20 ohms resistance in parallel with the thristor under test.

Conducting - on state

Parameter	Symbol	Min.	Max.	Typ.	Units	Conditions
Average value of on-state current	I _{T(AV)}			1275		Sinewave, 180° conduction, T _{sink} =55°C
Peak one cPSTCle surge (non repetitive) current	I _{TSM}		15500		A	10.0 msec (50Hz), sinusoidal wave-shape, 180° conduction, T _j = 125 °C
I square t	I ² t		1.2x10 ⁶		A ² s	10.0 msec
Latching current	I _L		1000		mA	V _D = 24 V; R _L = 12 ohms
Holding current	I _H		500		mA	V _D = 24 V; I = 2.5 A
Peak on-state voltage	V _{TM}		1.9		V	I _{TM} = 2000 A; T _j = 125 °C
Critical rate of rise of on-state current (5, 6)	di/dt		200		A/μs	Switching from V _{DRM} ≤ 1000 V, non-repetitive
Critical rate of rise of on-state current (6)	di/dt		100		A/μs	Switching from V _{DRM} ≤ 1000 V

ELECTRICAL CHARACTERISTICS AND RATINGS

R1275NS21H - Power

Thyristor

Gating

Parameter	Symbol	Min.	Max.	Typ.	Units	Conditions
Peak gate power dissipation	P_{GM}		200		W	$t_p = 40 \mu s$
Average gate power dissipation	$P_{G(AV)}$		5		W	
Peak gate current	I_{GM}		10		A	
Gate current required to trigger all units	I_{GT}		300 150 125		mA mA mA	$V_D = 6 V; R_L = 3 \text{ ohms}; T_j = -40^\circ C$ $V_D = 6 V; R_L = 3 \text{ ohms}; T_j = +25^\circ C$ $V_D = 6 V; R_L = 3 \text{ ohms}; T_j = +125^\circ C$
Gate voltage required to trigger all units	V_{GT}	0.30	5 3		V V V	$V_D = 6 V; R_L = 3 \text{ ohms}; T_j = -40^\circ C$ $V_D = 6 V; R_L = 3 \text{ ohms}; T_j = 0-125^\circ C$ $V_D = \text{Rated } V_{DRM}; R_L = 1000 \text{ ohms}; T_j = +125^\circ C$
Peak negative voltage	V_{GRM}		5		V	

Dynamic

Parameter	Symbol	Min.	Max.	Typ.	Units	Conditions
Delay time	t_d		1.5	0.7	μs	$I_{TM} = 500 A; V_D = \text{Rated } V_{DRM}$ Gate pulse: $V_G = 20 V; R_G = 20 \text{ ohms}; t_r = 0.1 \mu s; t_p = 20 \mu s$
Turn-off time (with $V_R = -50 V$)	t_q	55	65		μs	$I_{TM} = 1000 A; di/dt = 60 A/\mu s;$ $V_R \geq -50 V; \text{Re-applied } dV/dt = 20 V/\mu s \text{ linear to } 80\% V_{DRM}; V_G = 0;$ $T_j = 125^\circ C; \text{Duty cPSTCle} \geq 0.01\%$
Reverse recovery charge	Q_{rr}		*900		μC	$I_{TM} = 1000 A; di/dt = 60 A/\mu s;$ $V_R \geq -50 V$

* For guaranteed max. value, contact factory.

THERMAL AND MECHANICAL CHARACTERISTICS AND RATINGS

Parameter	Symbol	Min.	Max.	Typ.	Units	Conditions
Operating temperature	T_j	-40	+125		$^\circ C$	
Storage temperature	T_{stg}	-40	+150		$^\circ C$	
Thermal resistance - junction to case	$R_{\theta(j-s)}$		0.024 0.048		$^\circ C/W$	Double sided cooled Single sided cooled
Mounting force	P	4300 19.0	6000 26.7		lb. kN	
Weight	W			16 460	oz. g	

* Mounting surfaces smooth, flat and greased

Note : for case outline and dimensions, see case outline drawing in page 4 of this Technical Data

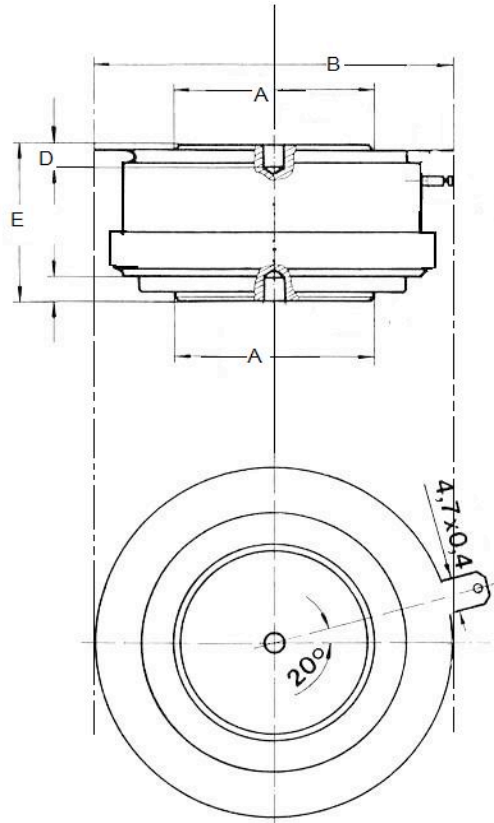

Sym	A	B	E
Inches	1.85	2.91	1.02
mm	47	75max	26±1.0