

## High Noise Immunity 42 V Input Voltage 70 mA Voltage Tracker for Automotive Applications

NO.EC-513-190411

### OVERVIEW

The R1540x is a voltage tracker featuring input voltage in the range of 3.5 V to 42 V. Highly accurate output voltage which attributes to CE/ADJ pin achieves successful sequence control of the integrated off-board sensor module. Strong enough not to require the circuit to avoid external electromagnetic interference (EMI) and this contributes space saving.

### KEY BENEFITS

- Excellent noise immunity provides effective shielding against EMI.
- Lower stand-by current consumption leads to energy saving of the whole system to prolong battery life.
- Response to requirements for sequence control in the system with integrated sensors.

### KEY SPECIFICATIONS

- Input Voltage Range (Maximum Rating):  
3.5 V to 42.0 V (50.0 V)
- Supply Current: Typ. 60  $\mu$ A
- Standby Current: Typ. 0.1  $\mu$ A
- Tracking Voltage Range: 2.2 V to 14 V
- Tracking Voltage Accuracy:  $\pm 15$  mV  
( $-40^{\circ}\text{C} \leq T_a \leq 125^{\circ}\text{C}$ ,  $V_{\text{CE/ADJ}} = 5$  V)
- Output Current 70 mA
- Ripple Rejection: Typ. 80 dB ( $f = 100$  Hz)
- Protections: Thermal Shutdown, Output Current Limiting and Short-circuit Current Limiting

### PACKAGE

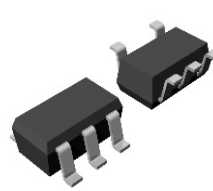

**SOT-23-5**  
2.9 x 2.8 x 1.1 (mm)

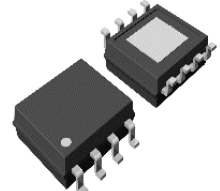

**HSOP-8E**  
5.2 x 6.2 x 1.45 (mm)

### TYPICAL APPLICATION

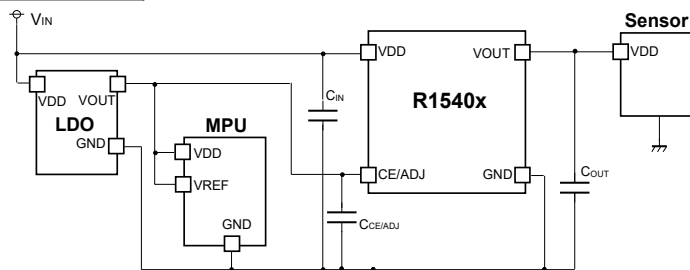

$C_{\text{IN}}$ : 0.1 $\mu$ F,  $C_{\text{OUT}}$ : 10 $\mu$ F,  $C_{\text{CE/ADJ}}$ : 0.1 $\mu$ F, Ceramic capacitor

### SELECTION GUIDE

Product Name	Package	Quantity per Reel
R1540N001B-TR-#E	SOT-23-5	3,000 pcs
R1540S001B-E2-#E	HSOP-8E	1,000 pcs

### APPLICATIONS

- Off-board sensors for automotive applications and power supply systems for analog to digital converters (ADC)

## SELECTION GUIDE

R1540x offers selectable packages and quality levels corresponding to user's purpose.

### Selection Guide

Product Name	Package	Quantity per Reel	Pb Free	Halogen Free
R1540N001B-TR-#E	SOT-23-5	3,000 pcs	Yes	Yes
R1540S001B-E2-#E	HSOP-8E	1,000 pcs	Yes	Yes

### #: Quality Class

#	Operating Temp. Range	Test Temp.
A	-40°C to 125°C	25°C, High
K	-40°C to 125°C	Low, 25°C, High

## BLOCK DIAGRAM

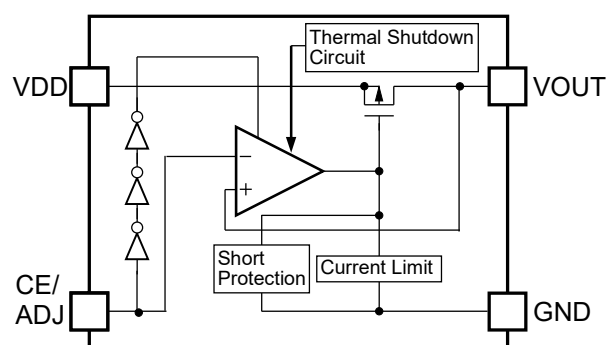

R1540x001B Block Diagram

## PIN DESCRIPTIONS

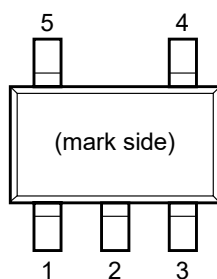

R1540N (SOT-23-5) Pin Configuration

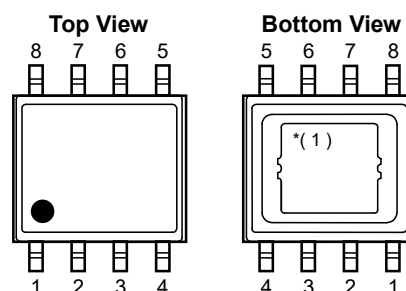

R1540S (HSOP-8E) Pin Configuration

### R1540N Pin Descriptions

Pin No.	Symbol	Description
1	CE/ADJ	Chip Enable and Adjustment Pin (Active - High)
2	GND <sup>(2)</sup>	Ground Pin
3	VDD	Input Pin
4	VOUT	Output Pin
5	GND <sup>(2)</sup>	Ground Pin

### R1540S Pin Descriptions

Pin No.	Symbol	Description
1	VDD	Input Pin
2	VDD	Input Pin
3	NC	No Contact
4	CE/ADJ	Chip Enable and Adjustment Pin (Active - High)
5	GND <sup>(2)</sup>	Ground Pin
6	GND <sup>(2)</sup>	Ground Pin
7	NC	No Contact
8	VOUT	Output Pin

<sup>(1)</sup> The tab on the bottom of the package is substrate potential (GND). It is recommended that this tab to be connected to the ground plane on the board.

<sup>(2)</sup> The GND pins must be wired together on the board.

**INTERNAL EQUIVALENT CIRCUIT FOR EACH PIN**

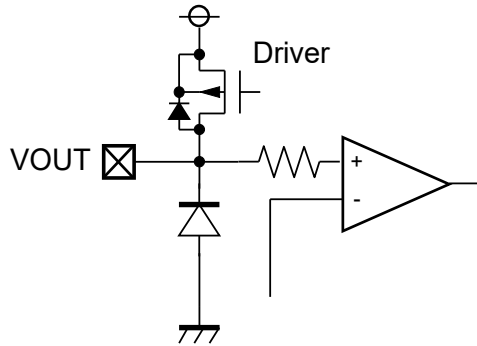

**VOUT Pin Internal Equivalent Circuit Diagrams**

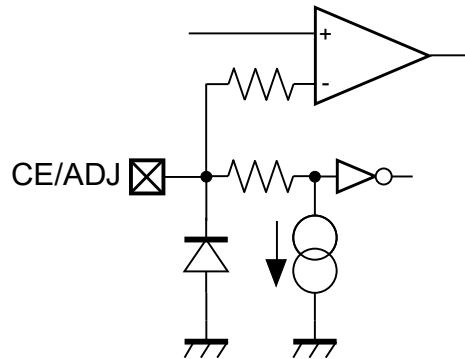

**CE/ADJ Pin Internal Equivalent Circuit Diagrams**

**ABSOLUTE MAXIMUM RATINGS**

Symbol	Parameter	Rating	Unit
$V_{IN}$	Input Voltage	-0.3 to 50	V
	Peak Voltage <sup>(1)</sup>	60	V
$V_{CE/ADJ}$	CE/ADJ Pin Input Voltage	-0.3 to 50	V
$V_{OUT}$	VOUT Pin Output Voltage	-0.3 to $V_{IN} + 0.3 \leq 50$	V
$I_{OUT}$	Output Current	95	mA
$P_D$	Power Dissipation <sup>(2)</sup> JEDEC STD. 51	SOT-23-5	830
		HSOP-8E	3600
$T_j$	Junction Temperature Range	-40 to 150	°C
$T_{stg}$	Storage Temperature Range	-55 to 150	°C

**ABSOLUTE MAXIMUM RATINGS**

Electronic and mechanical stress momentarily exceeded absolute maximum ratings may cause permanent damage and may degrade the life time and safety for both device and system using the device in the field. The functional operation at or over these absolute maximum ratings are not assured.

**RECOMMENDED OPERATING CONDITIONS**

Symbol	Parameter	Rating	Unit
$V_{IN}$	Input Voltage	3.5 to 42	V
$V_{CE/ADJ}$	CE/ADJ Input Pin Voltage	0 to 14	V
$T_a$	Operating Temperature Range	-40 to 125	°C

**RECOMMENDED OPERATING CONDITONS**

All of electronic equipment should be designed that the mounted semiconductor devices operate within the recommended operating conditions. The semiconductor devices cannot operate normally over the recommended operating conditions, even if they are used over such ratings by momentary electronic noise or surge. And the semiconductor devices may receive serious damage when they continue to operate over the recommended operating conditions.

<sup>(1)</sup> Duration time: 200 ms.

<sup>(2)</sup> Refer to POWER DISSIPATION for detailed information

## ELECTRICAL CHARACTERISTICS

$C_{IN} = 0.1 \mu\text{F}$ ,  $C_{OUT} = 10 \mu\text{F}$ ,  $V_{CE/ADJ} = 5.0 \text{ V}$  and  $V_{IN} = 14.0 \text{ V}$ , unless otherwise noted.

The specifications surrounded by   are guaranteed by design engineering at  $-40^\circ\text{C} \leq T_a \leq 125^\circ\text{C}$ .

### R1540x001B (-AE) Electrical Characteristics

( $T_a = 25^\circ\text{C}$ )

Symbol	Parameter	Conditions	Min.	Typ.	Max.	Unit
$I_{SS}$	Supply Current	$V_{IN} = 14 \text{ V}$ , $I_{OUT} = 0 \text{ mA}$		60	<span style="border: 1px solid black; padding: 0 2px;">100</span>	$\mu\text{A}$
$I_{standby}$	Standby Current	$V_{IN} = 42 \text{ V}$ , $V_{CE/ADJ} = 0 \text{ V}$		0.1	<span style="border: 1px solid black; padding: 0 2px;">1.0</span>	$\mu\text{A}$
$\Delta V_O$	Tracking Voltage Accuracy	$8 \text{ V} \leq V_{IN} \leq 24 \text{ V}$ $1 \text{ mA} \leq I_{OUT} \leq 70 \text{ mA}$	$V_{CE/ADJ} = 5.0 \text{ V}$		<span style="border: 1px solid black; padding: 0 2px;">15</span>	mV
		$6 \text{ V} \leq V_{IN} \leq 42 \text{ V}$ $1 \text{ mA} \leq I_{OUT} \leq 10 \text{ mA}$				
		$V_{IN} = 15 \text{ V}$ $I_{OUT} = 1 \text{ mA}$	$2.2 \text{ V} \leq V_{CE/ADJ} \leq 5.0 \text{ V}$	<span style="border: 1px solid black; padding: 0 2px;">-15</span>	<span style="border: 1px solid black; padding: 0 2px;">15</span>	mV
		$5.0 \text{ V} < V_{CE/ADJ} \leq 14.0 \text{ V}$	<span style="border: 1px solid black; padding: 0 2px;">-18</span>		<span style="border: 1px solid black; padding: 0 2px;">18</span>	mV
$\frac{\Delta V_{OUT}}{\Delta I_{OUT}}$	Load Regulation	$V_{IN} = 8 \text{ V}$ , $1 \text{ mA} \leq I_{OUT} \leq 70 \text{ mA}$	<span style="border: 1px solid black; padding: 0 2px;">-2</span>		<span style="border: 1px solid black; padding: 0 2px;">2</span>	mV
$\frac{\Delta V_{OUT}}{\Delta V_{IN}}$	Line Regulation	$6 \text{ V} \leq V_{IN} \leq 42 \text{ V}$ , $I_{OUT} = 1 \text{ mA}$	<span style="border: 1px solid black; padding: 0 2px;">-8</span>		<span style="border: 1px solid black; padding: 0 2px;">8</span>	mV
$\frac{\Delta V_{OUT}}{\Delta V_{CE/ADJ}}$	CE/ADJ Regulation	$2.2 \text{ V} \leq V_{CE/ADJ} \leq 14 \text{ V}$ , $I_{OUT} = 1 \text{ mA}$ , $V_{IN} = 15 \text{ V}$	<span style="border: 1px solid black; padding: 0 2px;">-1</span>		<span style="border: 1px solid black; padding: 0 2px;">1</span>	mV/V
$V_{DIF}$	Dropout Voltage	$I_{OUT} = 70 \text{ mA}$		1.3	<span style="border: 1px solid black; padding: 0 2px;">2.1</span>	V
$I_{LIM}$	Output Current Limit	$V_{IN} = 8 \text{ V}$	<span style="border: 1px solid black; padding: 0 2px;">80</span>	120		mA
$I_{SC}$	Short Current Limit	$V_{IN} = 8 \text{ V}$ , $V_{OUT} = 0 \text{ V}$	<span style="border: 1px solid black; padding: 0 2px;">20</span>	40		mA
$V_{CE/ADJH}$	CE/ADJ Pin Input Voltage, high	$V_{IN} = 15 \text{ V}$	<span style="border: 1px solid black; padding: 0 2px;">2.0</span>		<span style="border: 1px solid black; padding: 0 2px;">14</span>	V
$V_{CE/ADJL}$	CE/ADJ Pin Input Voltage, low	$V_{IN} = 42 \text{ V}$	<span style="border: 1px solid black; padding: 0 2px;">0</span>		<span style="border: 1px solid black; padding: 0 2px;">1.0</span>	V
$I_{PD}$	CE/ADJ Pin Pull Down Current	$V_{IN} = 42 \text{ V}$ , $V_{CE/ADJ} = 2 \text{ V}$		0.2	<span style="border: 1px solid black; padding: 0 2px;">1.0</span>	$\mu\text{A}$
$T_{TSD}$	Thermal Shutdown Detection Temperature	Junction Temperature	150	165		$^\circ\text{C}$
$T_{TSR}$	Thermal Shutdown Released Temperature	Junction Temperature	128	135		$^\circ\text{C}$

All test items listed under Electrical Characteristics are done under the pulse load condition ( $T_j \approx T_a = 25^\circ\text{C}$ ).

$C_{IN} = 0.1 \mu\text{F}$ ,  $C_{OUT} = 10 \mu\text{F}$ ,  $V_{CE/ADJ} = 5.0 \text{ V}$  and  $V_{IN} = 14.0 \text{ V}$ , unless otherwise noted.

## R1540x001B (-KE) Electrical Characteristics

( $-40^{\circ}\text{C} \leq T_a \leq 125^{\circ}\text{C}$ )

Symbol	Parameter	Conditions	Min.	Typ.	Max.	Unit
$I_{SS}$	Supply Current	$V_{IN} = 14 \text{ V}$ , $I_{OUT} = 0 \text{ mA}$		60	100	$\mu\text{A}$
$I_{standby}$	Standby Current	$V_{IN} = 42 \text{ V}$ , $V_{CE/ADJ} = 0 \text{ V}$		0.1	1.0	$\mu\text{A}$
$\Delta V_O$	Tracking Voltage Accuracy	$8 \text{ V} \leq V_{IN} \leq 24 \text{ V}$ $1 \text{ mA} \leq I_{OUT} \leq 70 \text{ mA}$	$V_{CE/ADJ} = 5.0 \text{ V}$	-15	15	mV
		$6 \text{ V} \leq V_{IN} \leq 42 \text{ V}$ $1 \text{ mA} \leq I_{OUT} \leq 10 \text{ mA}$				
		$V_{IN} = 15 \text{ V}$ $I_{OUT} = 1 \text{ mA}$	$2.2 \text{ V} \leq V_{CE/ADJ} \leq 5.0 \text{ V}$	-15	15	mV
	$5.0 \text{ V} < V_{CE/ADJ} \leq 14.0 \text{ V}$	-18	18			
$\Delta V_{OUT} / \Delta I_{OUT}$	Load Regulation	$V_{IN} = 8 \text{ V}$ , $1 \text{ mA} \leq I_{OUT} \leq 70 \text{ mA}$	-2		2	mV
$\Delta V_{OUT} / \Delta V_{IN}$	Line Regulation	$6 \text{ V} \leq V_{IN} \leq 42 \text{ V}$ , $I_{OUT} = 1 \text{ mA}$	-8		8	mV
$\Delta V_{OUT} / \Delta V_{CE/ADJ}$	CE/ADJ Regulation	$2.2 \text{ V} \leq V_{CE/ADJ} \leq 14 \text{ V}$ , $I_{OUT} = 1 \text{ mA}$ , $V_{IN} = 15 \text{ V}$	-1		1	mV/V
$V_{DIF}$	Dropout Voltage	$I_{OUT} = 70 \text{ mA}$		1.3	2.1	V
$I_{LIM}$	Output Current Limit	$V_{IN} = 8 \text{ V}$	80	120		mA
$I_{SC}$	Short Current Limit	$V_{IN} = 8 \text{ V}$ , $V_{OUT} = 0 \text{ V}$	20	40		mA
$V_{CE/ADJH}$	CE/ADJ Pin Input Voltage, high	$V_{IN} = 15 \text{ V}$	2.0		14	V
$V_{CE/ADJL}$	CE/ADJ Pin Input Voltage, low	$V_{IN} = 42 \text{ V}$	0		1.0	V
$I_{PD}$	CE/ADJ Pin Pull Down Current	$V_{IN} = 42 \text{ V}$ , $V_{CE/ADJ} = 2 \text{ V}$		0.2	1.0	$\mu\text{A}$
$T_{TSD}$	Thermal Shutdown Detection Temperature	Junction Temperature	150	165		$^{\circ}\text{C}$
$T_{TSR}$	Thermal Shutdown Released Temperature	Junction Temperature	128	135		$^{\circ}\text{C}$

All test items listed under Electrical Characteristics are done under the pulse load condition ( $T_j \approx T_a = 25^{\circ}\text{C}$ ).

## TYPICAL APPLICATION

### TYPICAL APPLICATION

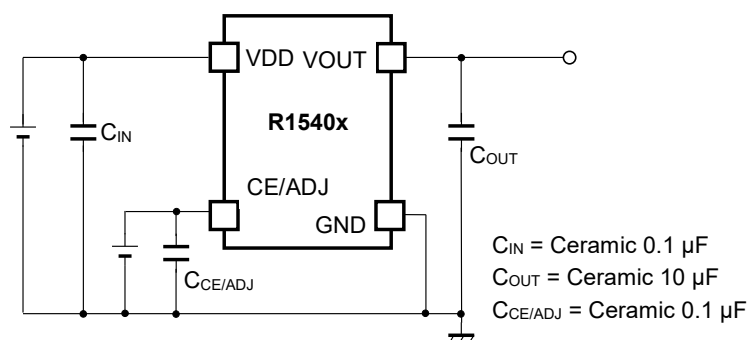

R1540x Typical Application

## TECHNICAL NOTES

### Phase Compensation

R1540x adopts capacitance and Equivalent Series Resistance (ESR) for phase compensation to ensure stable operation even with load varying current. For this end, the capacitor of 10  $\mu$ F or more is essential. A certain amount of ESR may cause unstable output voltage. Fully take temperature and frequency characteristics into consideration when evaluating the circuit. Place the capacitor of 0.1  $\mu$ F or more between VDD and GND with using short leads and short printed circuit traces.

### PCB Layout

SOT-23-5 package: connect Nos. 2 and 5 of GND pin together.

HSOP-8E package: connect Nos. 5 and 6 of GND pin together.



**ESR vs. output current characteristics**

Using ceramic output capacitor is highly recommended although availability of another low-ESR capacitors. The mutual relations between the output current ( $I_{OUT}$ ) causes noise under the specified value and the ESR are indicated below for reference.

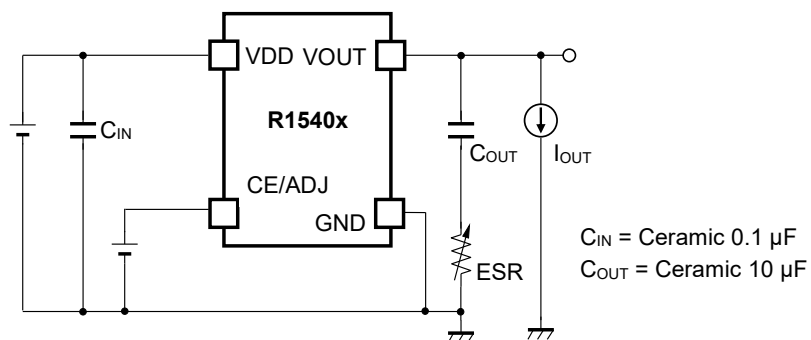

**Measurement Conditions**

Frequency Band: 10 Hz to 2 MHz

Temperature: -40°C to 125°C

Shaded portion: Noise level is 40 μV (average) or below

Capacitors:  $C_{IN}$  = 0.1 μF of Ceramic,  $C_{OUT}$  = 10 μF of Ceramic

**R1540x001B**

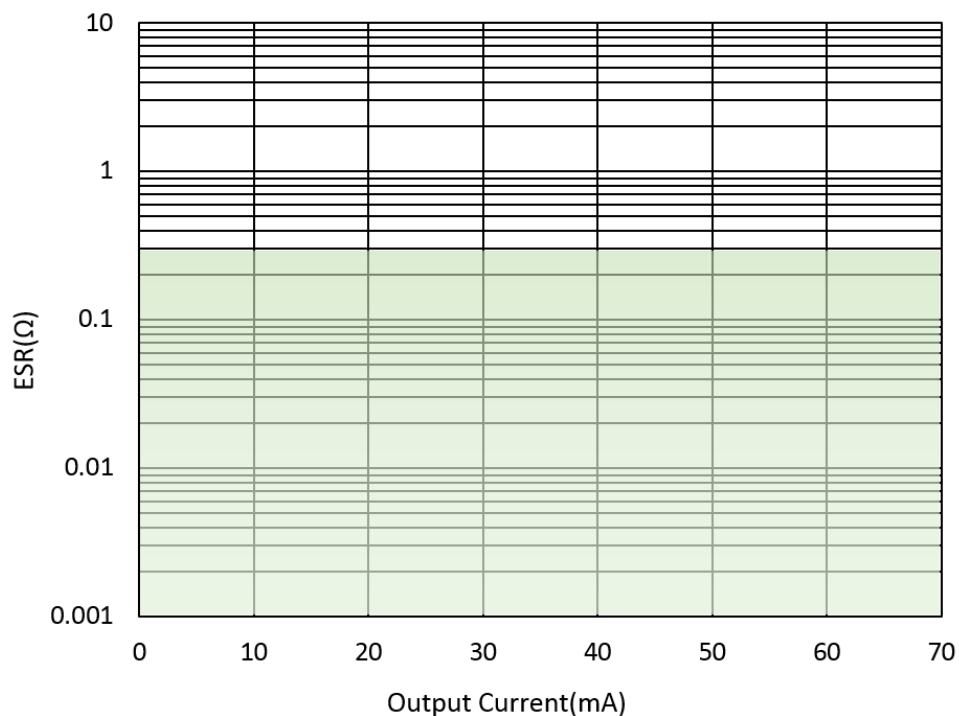

## **THEORY OF OPERATION**

### **Thermal Shutdown**

Thermal Shutdown occurs when the device's junction temperature reaches 165°C (Typ.) at which point the regulator will automatically shut down. Then the regulator resumes from the stand-by state when the junction temperature decreases below 135°C (Typ.). Unless the cause of overheating is eliminated, the device cycles on and off to generate pulse output.

## APPLICATION INFORMATION

### Typical Application for IC Chip Breakdown Prevention

A sudden surge of current flowing through the VOUT pin during a short to GND leads to negative voltage due to resonance generated between the impedance of the wire and the output capacitor, C<sub>2</sub>. Consequently, large short-circuit current may destroy the IC or a load device in some types of pattern boards. It is highly recommended to connect schottky diode, D1, between VOUT pin and GND to prevent the IC from being destroyed.

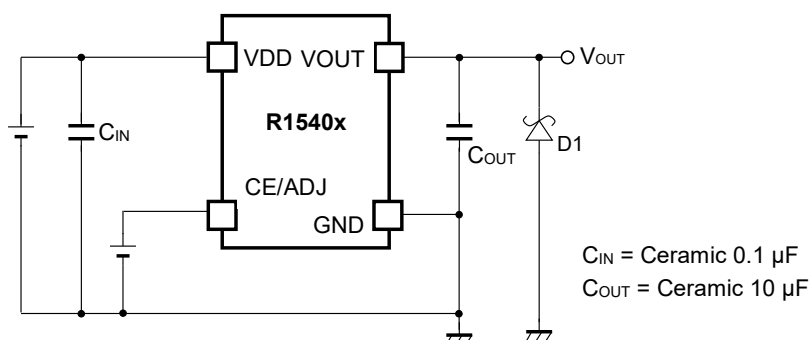

**R1540x Typical Application for IC Chip Breakdown Prevention**

## Electromagnetic Noise Immunity

An output voltage may linearly varies in some regulators due to electromagnetic noise. R1540x adopts the techniques on its circuits to prevent this voltage variation. The noise immunity test indicated below was conducted to confirm that R1540x is fairly robust to electromagnetic noise over a broad frequency band.

DC power supply : apply  $V_{IN} = 14\text{ V}$ ,  $V_{CE/ADJ} = 5\text{ V}$

Digital multi meter : measure the output DC voltage of R1540

Signal generator : apply high frequency signal of 150 kHz to 1 GHz

Power meter : measure the intensity of signal so as to sense the surface electric field intensity of 800 V/m

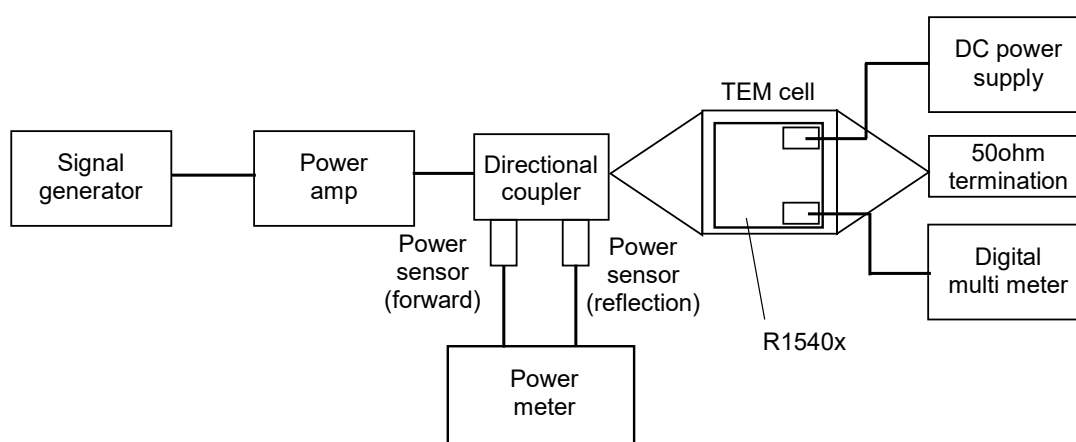

**Block Diagram for Immunity Test Based on IEC 62132-2 TEM cell**

EMS Characteristics (TEMcell Applied : 800 V/m)

$V_{IN} = 14\text{ V}$ ,  $V_{CE/ADJ} = 5\text{ V}$ ,

Surface Electric Field Intensity = 800 V/m

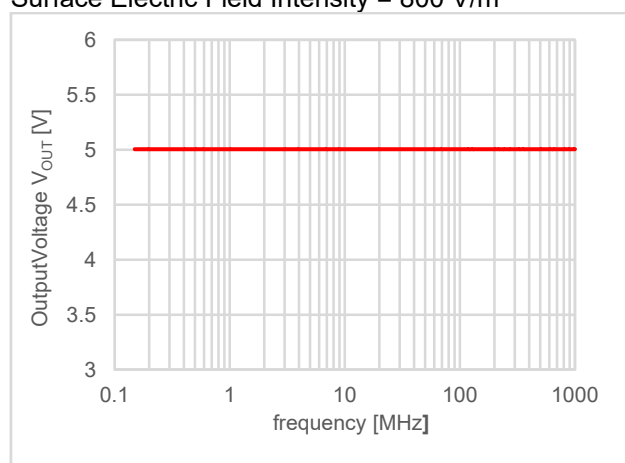

## TYPICAL CHARACTERISTICS

Typical Characteristics are intended to be used as reference data, they are not guaranteed

### 1) Output voltage vs Output Current

$C_{IN}$  = Ceramic 0.1  $\mu$ F,  $C_{OUT}$  = Ceramic 10  $\mu$ F,  $T_a$  = 25°C

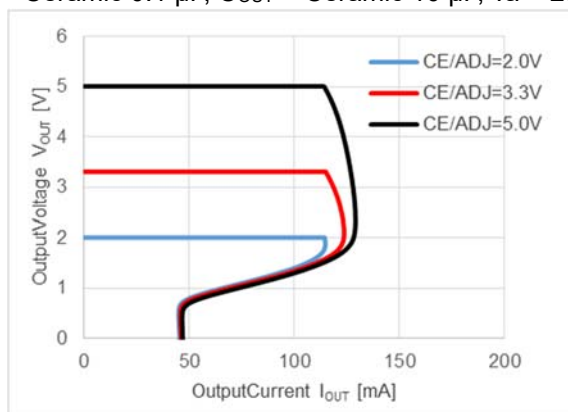

### 2) Output voltage vs Input Voltage

$C_{IN}$  = Ceramic 0.1  $\mu$ F,  $C_{OUT}$  = Ceramic 10  $\mu$ F,  $T_a$ =25°C

$V_{IN}$  = 0 V,  $\leq$  42 V,  $V_{CE/ADJ}$  = 5 V

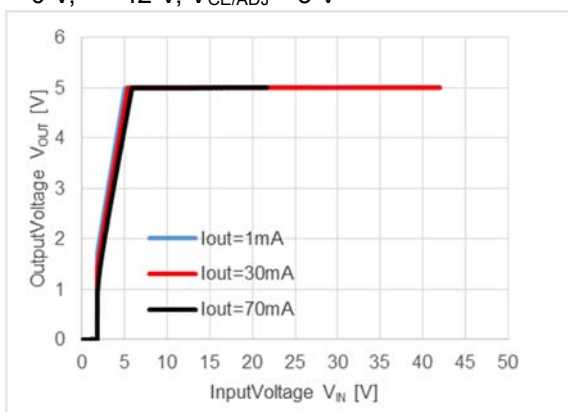

$V_{IN}$  = 0 V,  $\leq$  8 V,  $V_{CE/ADJ}$  = 5 V

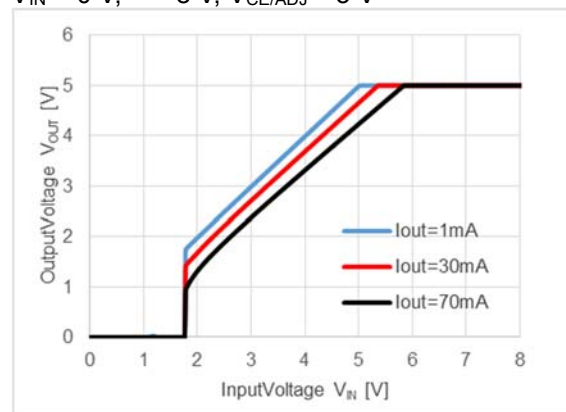

### 3) Supply Current vs Input Voltage

$C_{IN}$  = Ceramic 0.1  $\mu$ F,  $C_{OUT}$  = Ceramic 10  $\mu$ F,  $T_a$  = 25°C

$V_{IN}$  = 0 V  $\leq$  42 V,  $V_{CE/ADJ}$  = 5 V,  $I_{OUT}$  = 0 mA

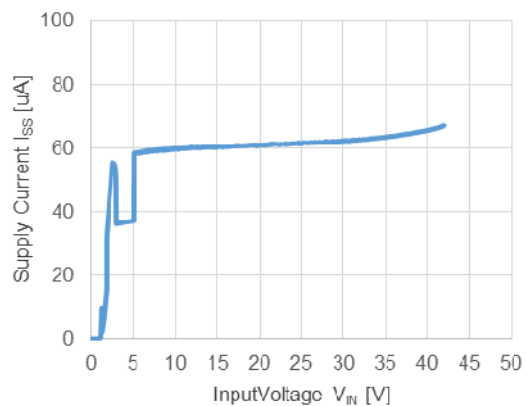

## 4) Supply Current vs Temperature

$C_{IN}$  = Ceramic 0.1  $\mu$ F,  $C_{OUT}$  = Ceramic 10  $\mu$ F

$V_{IN}$  = 14 V,  $V_{CE/ADJ}$  = 5 V,  $I_{OUT}$  = 0 mA

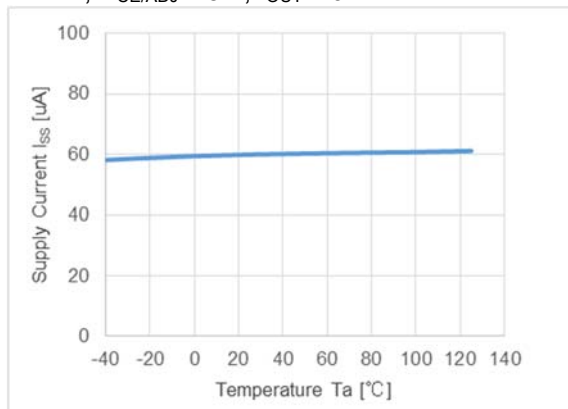

## 5) Tracking Accuracy vs Temperature

$C_{IN}$  = Ceramic 0.1  $\mu$ F,  $C_{OUT}$  = Ceramic 10  $\mu$ F

$V_{IN}$  = 14 V,  $V_{CE/ADJ}$  = 5 V,  $I_{OUT}$  = 1 mA

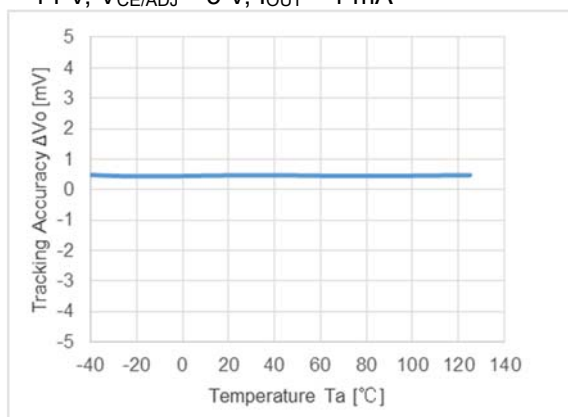

## 6) Tracking Accuracy vs Input Voltage

$C_{IN}$  = Ceramic 0.1  $\mu$ F,  $C_{OUT}$  = Ceramic 10  $\mu$ F,

$T_a = 25^\circ\text{C}$

$V_{CE/ADJ} = 2$  V,  $V_{IN} = 3$  V  $\Leftrightarrow$  42 V

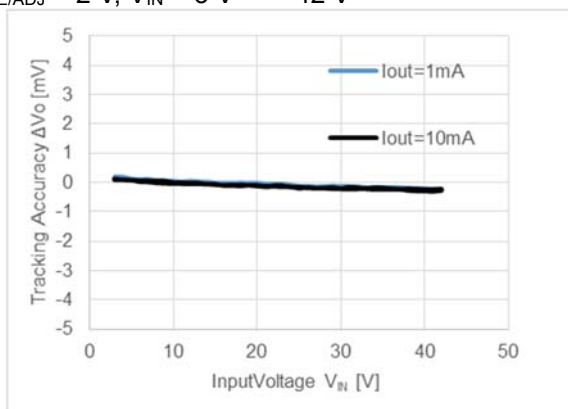

$V_{CE/ADJ} = 5$  V,  $V_{IN} = 6$  V  $\Leftrightarrow$  42 V

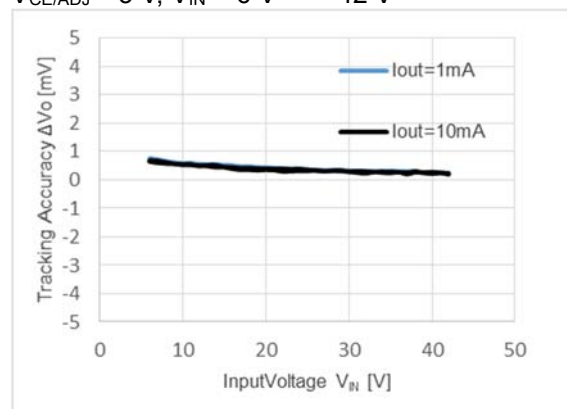

## 7) Tracking Accuracy vs Load Current

$C_{IN}$  = Ceramic 0.1  $\mu$ F,  $C_{OUT}$  = Ceramic 10  $\mu$ F,  $T_a$  = 25°C

$V_{CE/ADJ}$  = 2 V,  $I_{OUT}$  = 1mA  $\Leftrightarrow$  70 mA

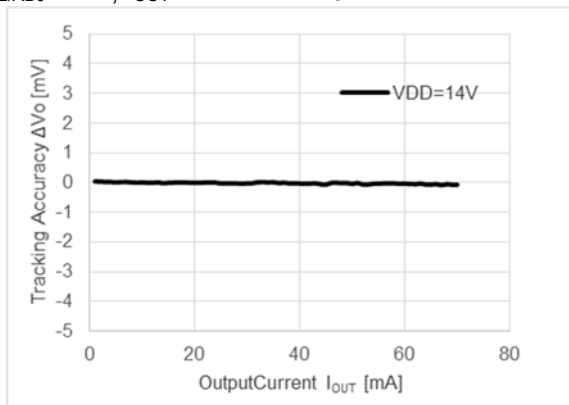

$V_{CE/ADJ}$  = 5 V,  $I_{OUT}$  = 1mA  $\Leftrightarrow$  70 mA

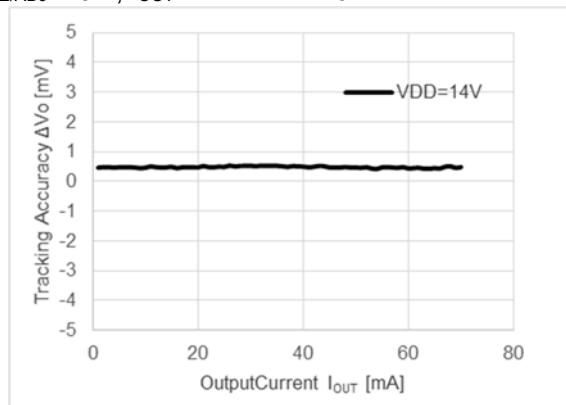

## 8) Tracking Accuracy vs CE/ADJ Voltage

$C_{IN}$  = Ceramic 0.1  $\mu$ F,  $C_{OUT}$  = Ceramic 10  $\mu$ F,

$T_a$  = 25°C

$V_{IN}$  = 15 V,  $V_{CE/ADJ}$  = 2.4 V  $\Leftrightarrow$  14 V,  $I_{OUT}$  = 1 mA

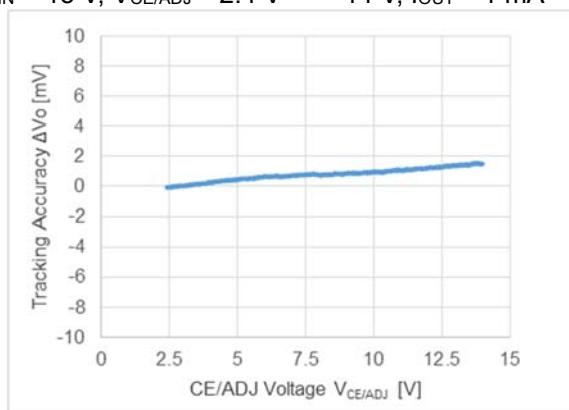

## 9) Dropout Voltage vs Output Current

$C_{IN}$  = Ceramic 0.1  $\mu$ F,  $C_{OUT}$  = Ceramic 10  $\mu$ F,  $T_a$ =25°C

$V_{IN}$  = 0 V  $\Leftrightarrow$  22 V,  $V_{CE/ADJ}$  = 5 V

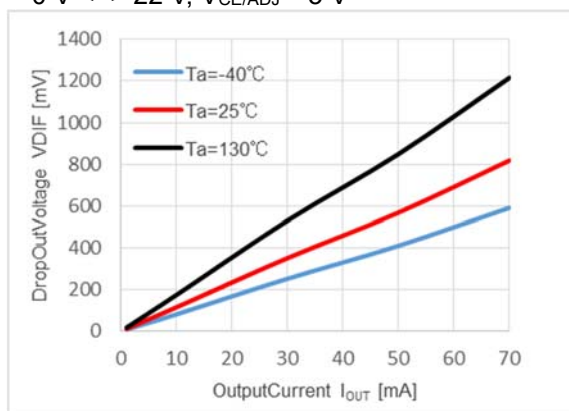

10) Dropout Voltage vs CE/ADJ Voltage  
 $C_{IN}$  = Ceramic 0.1  $\mu$ F,  $C_{OUT}$  = Ceramic 10  $\mu$ F,  $T_a=25^\circ\text{C}$   
 $V_{IN} = 0\text{ V} \Leftrightarrow 22\text{ V}$ ,  $I_{OUT}=70\text{ mA}$

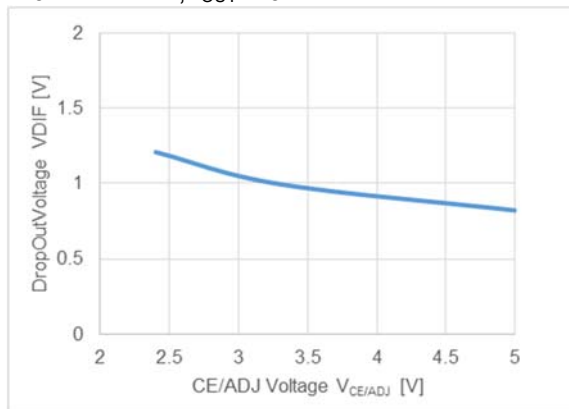

11) Equivalent Series Resistance vs Output Current  
 $C_{IN}$  = Ceramic 0.1  $\mu$ F,  $C_{OUT}$  = Ceramic 10 $\mu$ F,  $T_a=25^\circ\text{C}$   
 $V_{IN} = 4\text{ V} \Leftrightarrow 42\text{ V}$ ,  $V_{CE/ADJ} = 2\text{ V}$   
 $T_a = -40^\circ\text{C} / 25^\circ\text{C} / 130^\circ\text{C}$

$V_{IN} = 7\text{ V} \Leftrightarrow 42\text{ V}$ ,  $V_{CE/ADJ} = 5\text{ V}$   
 $T_a = -40^\circ\text{C} / 25^\circ\text{C} / 130^\circ\text{C}$

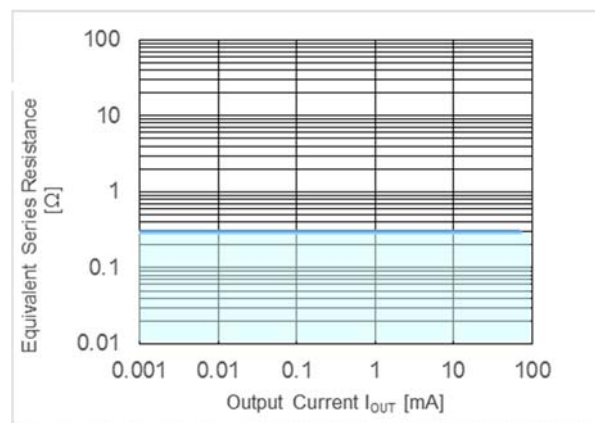
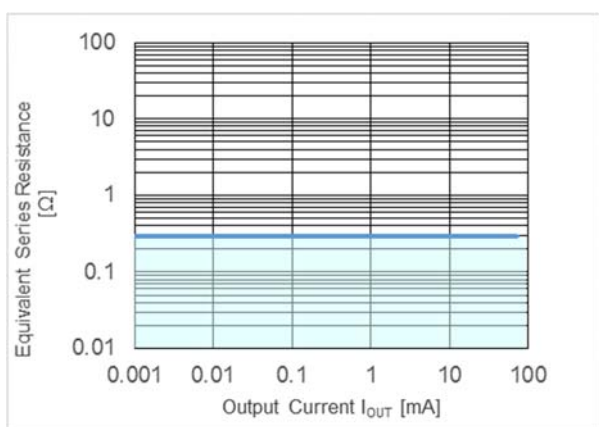

12) Ripple Rejection vs Input Voltage  
 $C_{IN}$  = none,  $C_{OUT}$  = Ceramic 10  $\mu$ F,  $T_a = 25^\circ\text{C}$   
 $V_{IN} = 5\text{ V} \Leftrightarrow 15\text{ V}$ ,  $V_{CE/ADJ} = 5\text{ V}$

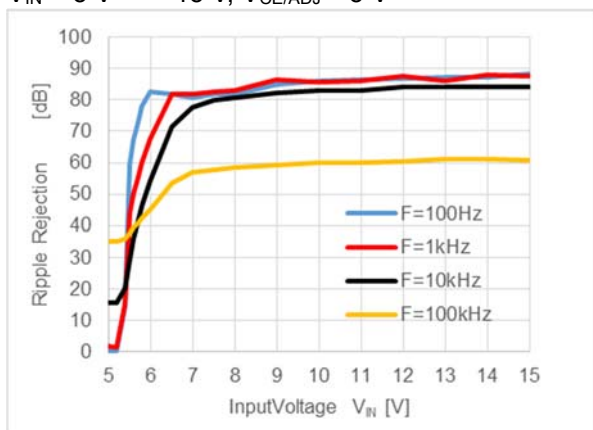



## 13) Ripple Rejection vs Frequency

$C_{IN}$  = none,  $C_{OUT}$  = Ceramic 10  $\mu$ F,  $T_a$  = 25°C

$V_{IN}$  = 14 V,  $V_{CE/ADJ}$  = 2 V

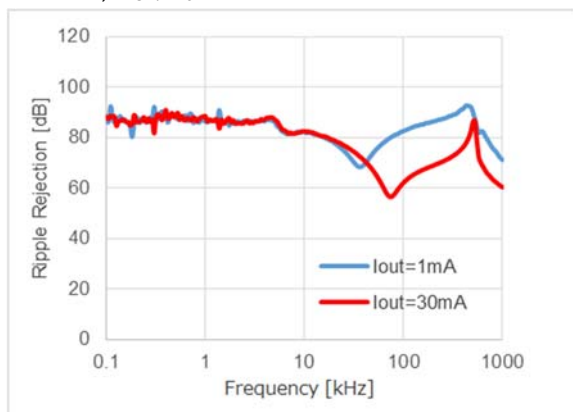

## 14) Load Transient Response

$C_{IN}$  = Ceramic 0.1  $\mu$ F,  $C_{OUT}$  = Ceramic 10  $\mu$ F,  $T_a$  = 25°C

$V_{IN}$  = 14 V,  $I_{OUT}$  = 1 mA  $\leftrightarrow$  50 mA,  $t_R$  =  $t_F$  = 1  $\mu$ s

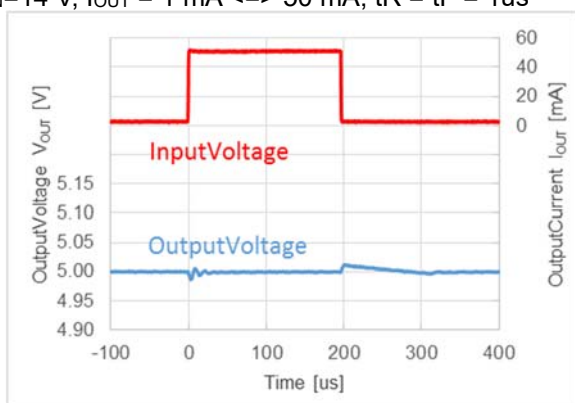

## 15) Input Transient Response

$C_{IN}$  = none,  $C_{OUT}$  = Ceramic 10  $\mu$ F,  $T_a$  = 25°C

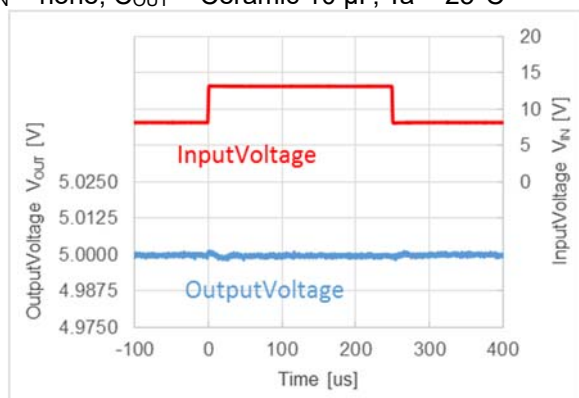

16) Turn-on Speed with CE/ADJ pin

$C_{IN}$  = Ceramic 0.1  $\mu$ F,  $C_{OUT}$  = Ceramic 10  $\mu$ F,  $T_a$  = 25°C

$V_{IN}$ =14 V,  $V_{CE/ADJ}$  = 0 V => 5 V

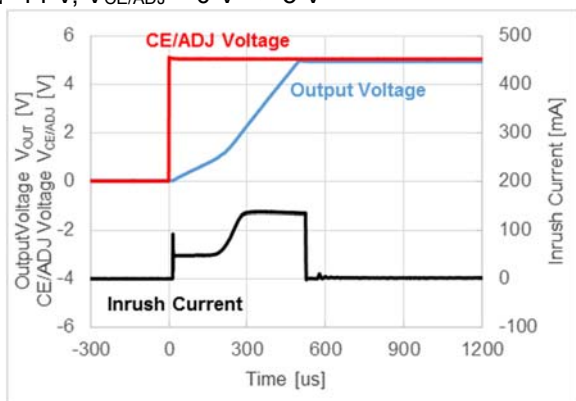

17) Turn-off Speed with CE/ADJ pin

$C_{IN}$  = Ceramic 0.1  $\mu$ F,  $C_{OUT}$  = Ceramic 10 $\mu$ F,  $T_a$  = 25°C

$V_{IN}$ =14 V,  $V_{CE/ADJ}$  = 5 V => 0 V

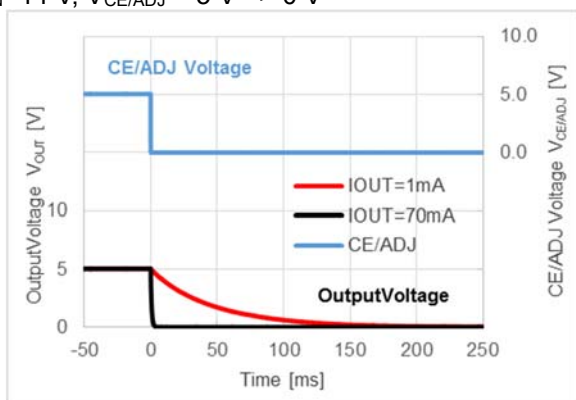

18) CE/ADJ Excess/Inrush Current

$C_{IN}$  = none,  $C_{OUT}$  = Ceramic 10 $\mu$ F,  $T_a$  = 25°C

$V_{IN}$  = 8 V,  $V_{CE/ADJ}$  = 2.4 V => 5 V

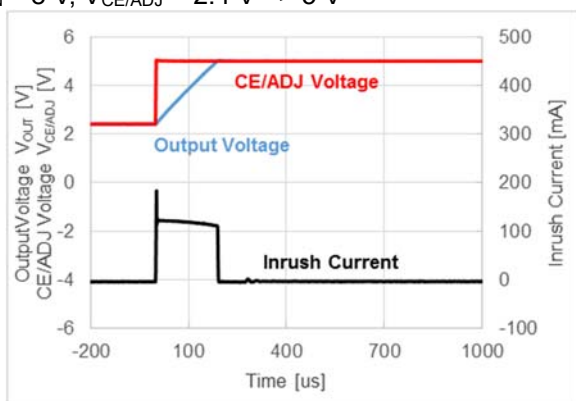

$V_{IN}$  = 8 V,  $V_{CE/ADJ}$  = 5 V => 2.4 V

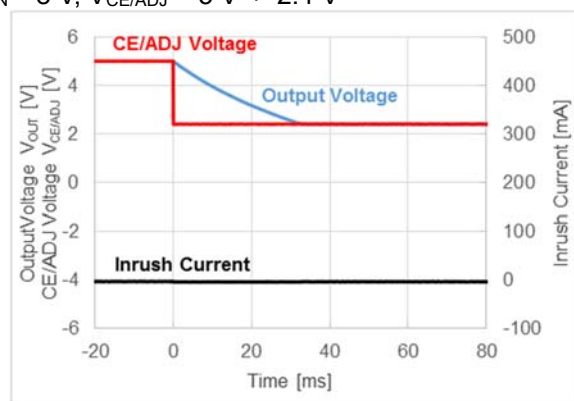

19) Load Dump

$C_{IN}$  = Ceramic 0.1  $\mu$ F,  $C_{OUT}$  = Ceramic 10  $\mu$ F,  $T_a$  = 25°C

$V_{CE/ADJ}$  = 5 V

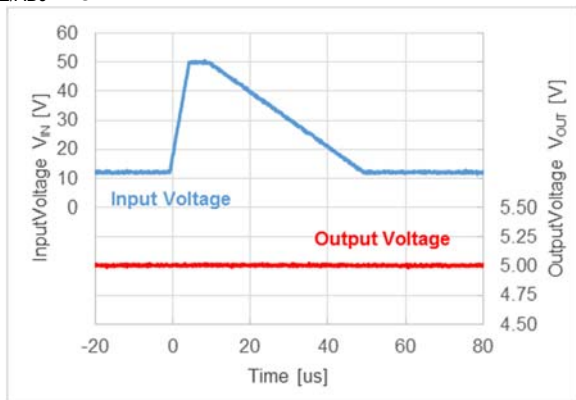

20) Cranking

$C_{IN}$  = Ceramic 0.1  $\mu$ F,  $C_{OUT}$  = Ceramic 10  $\mu$ F,  $T_a$  = 25°C

$V_{CE/ADJ}$  = 5 V,  $I_{OUT}$  = 1 mA

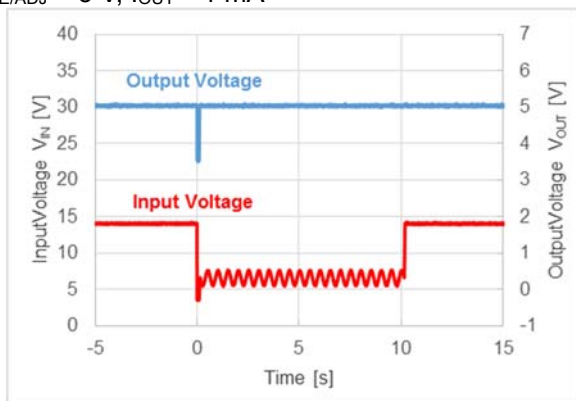

$V_{CE/ADJ}$  = 5 V,  $I_{OUT}$  = 50 mA

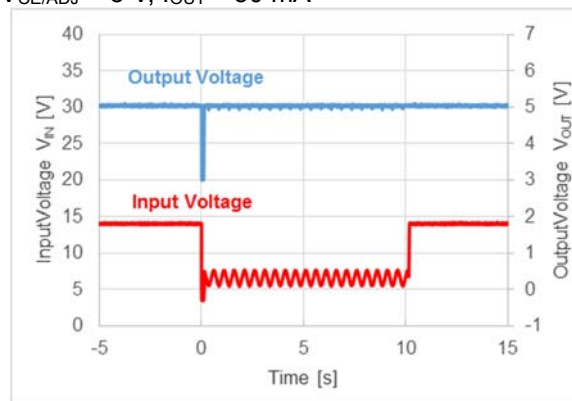

$V_{CE/ADJ}$  = 5 V,  $I_{OUT}$  = 1 mA

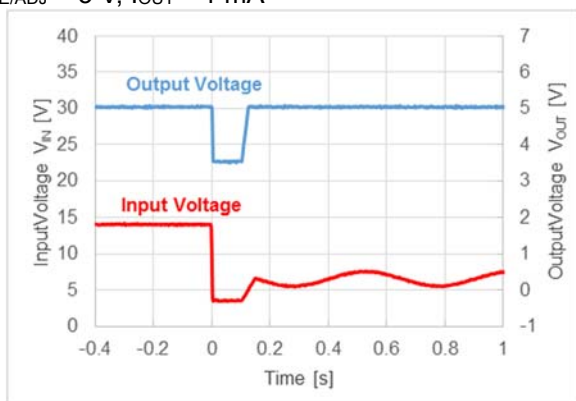

$V_{CE/ADJ}$  = 5 V,  $I_{OUT}$  = 50 mA

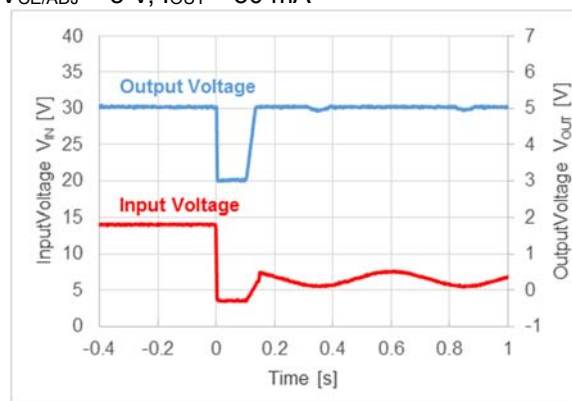

## Test Circuit

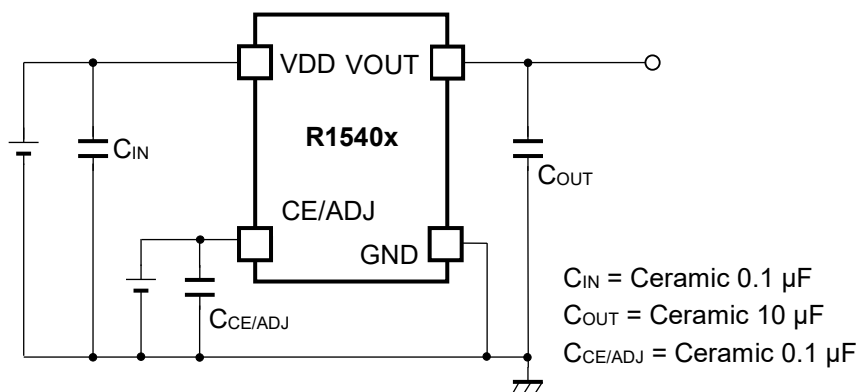

## R1540x circuit for measuring Typical Characteristics

## Measurement Components of Typical Characteristics

Symbol	Capacitance	Measurement item	Manufacturer	Parts number
$C_{IN}$	0.1 $\mu$ F	All	TDK	CGA4J2X7R2A104K125AA
$C_{OUT}$	10 $\mu$ F	All	TDK	CGA6P1X7R1E106K

The power dissipation of the package is dependent on PCB material, layout, and environmental conditions. The following measurement conditions are based on JEDEC STD. 51-7.

**Measurement Conditions**

Item	Measurement Conditions
Environment	Mounting on Board (Wind Velocity = 0 m/s)
Board Material	Glass Cloth Epoxy Plastic (Four-Layer Board)
Board Dimensions	76.2 mm × 114.3 mm × 0.8 mm
Copper Ratio	Outer Layer (First Layer): Less than 95% of 50 mm Square Inner Layers (Second and Third Layers): Approx. 100% of 50 mm Square Outer Layer (Fourth Layer): Approx. 100% of 50 mm Square
Through-holes	φ 0.3 mm × 7 pcs

**Measurement Result**

(Ta = 25°C, Tjmax = 150°C)

Item	Measurement Result
Power Dissipation	830 mW
Thermal Resistance (θja)	θja = 150°C/W
Thermal Characterization Parameter (ψjt)	ψjt = 51°C/W

θja: Junction-to-Ambient Thermal Resistance

ψjt: Junction-to-Top Thermal Characterization Parameter

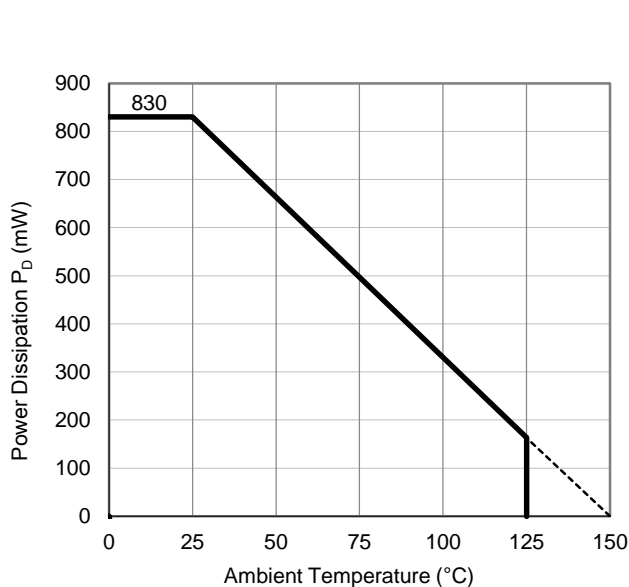

**Power Dissipation vs. Ambient Temperature**

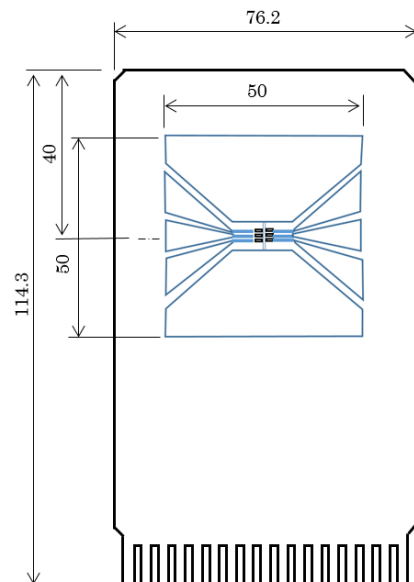

**Measurement Board Pattern**

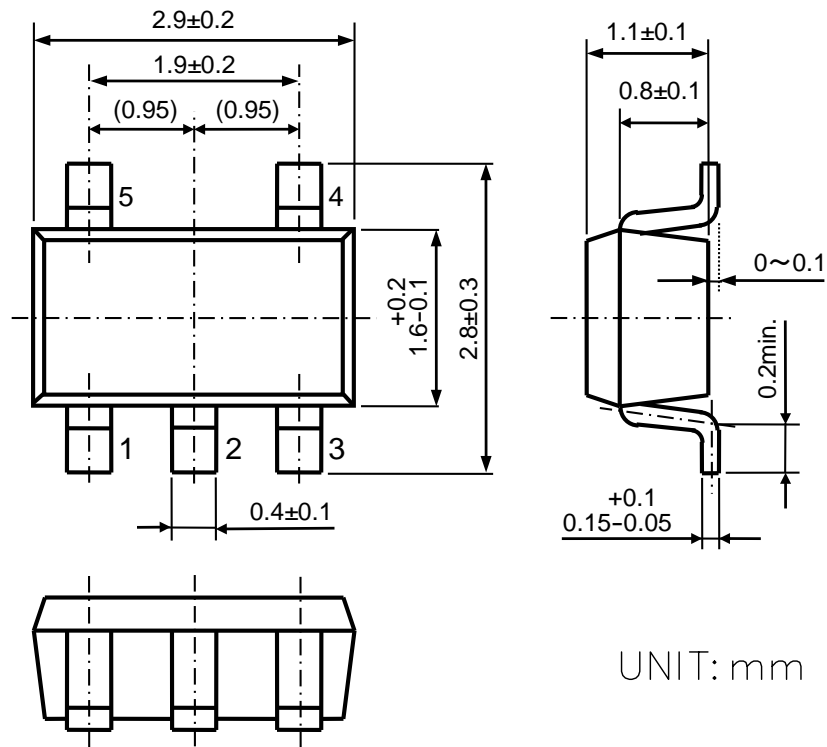

UNIT: mm

SOT-23-5 Package Dimensions

The power dissipation of the package is dependent on PCB material, layout, and environmental conditions. The following measurement conditions are based on JEDEC STD. 51-7.

**Measurement Conditions**

Item	Measurement Conditions
Environment	Mounting on Board (Wind Velocity = 0 m/s)
Board Material	Glass Cloth Epoxy Plastic (Four-Layer Board)
Board Dimensions	76.2 mm x 114.3 mm x 0.8 mm
Copper Ratio	Outer Layer (First Layer): Less than 95% of 50 mm Square Inner Layers (Second and Third Layers): Approx. 100% of 50 mm Square Outer Layer (Fourth Layer): Approx. 100% of 50 mm Square
Through-holes	φ 0.3 mm x 21 pcs

**Measurement Result**

(Ta = 25°C, Tjmax = 150°C)

Item	Measurement Result
Power Dissipation	3600 mW
Thermal Resistance (θja)	θja = 34.5°C/W
Thermal Characterization Parameter (ψjt)	ψjt = 10°C/W

θja: Junction-to-Ambient Thermal Resistance

ψjt: Junction-to-Top Thermal Characterization Parameter

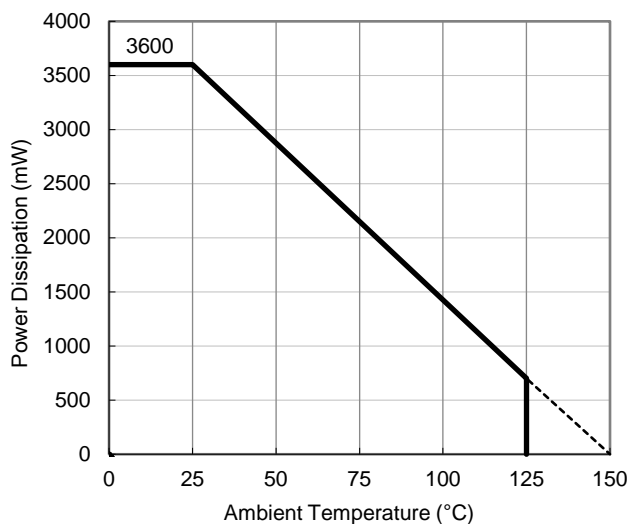

**Power Dissipation vs. Ambient Temperature**

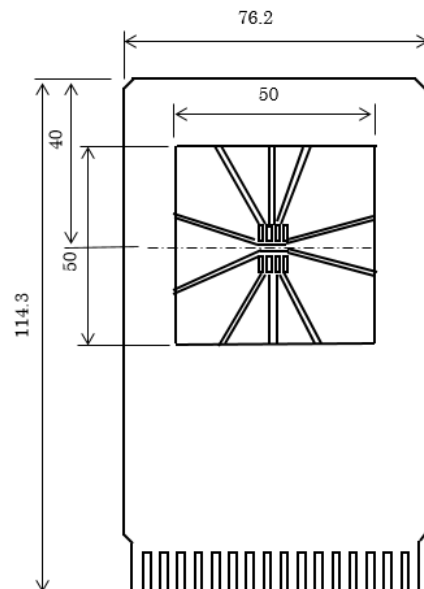

**Measurement Board Pattern**

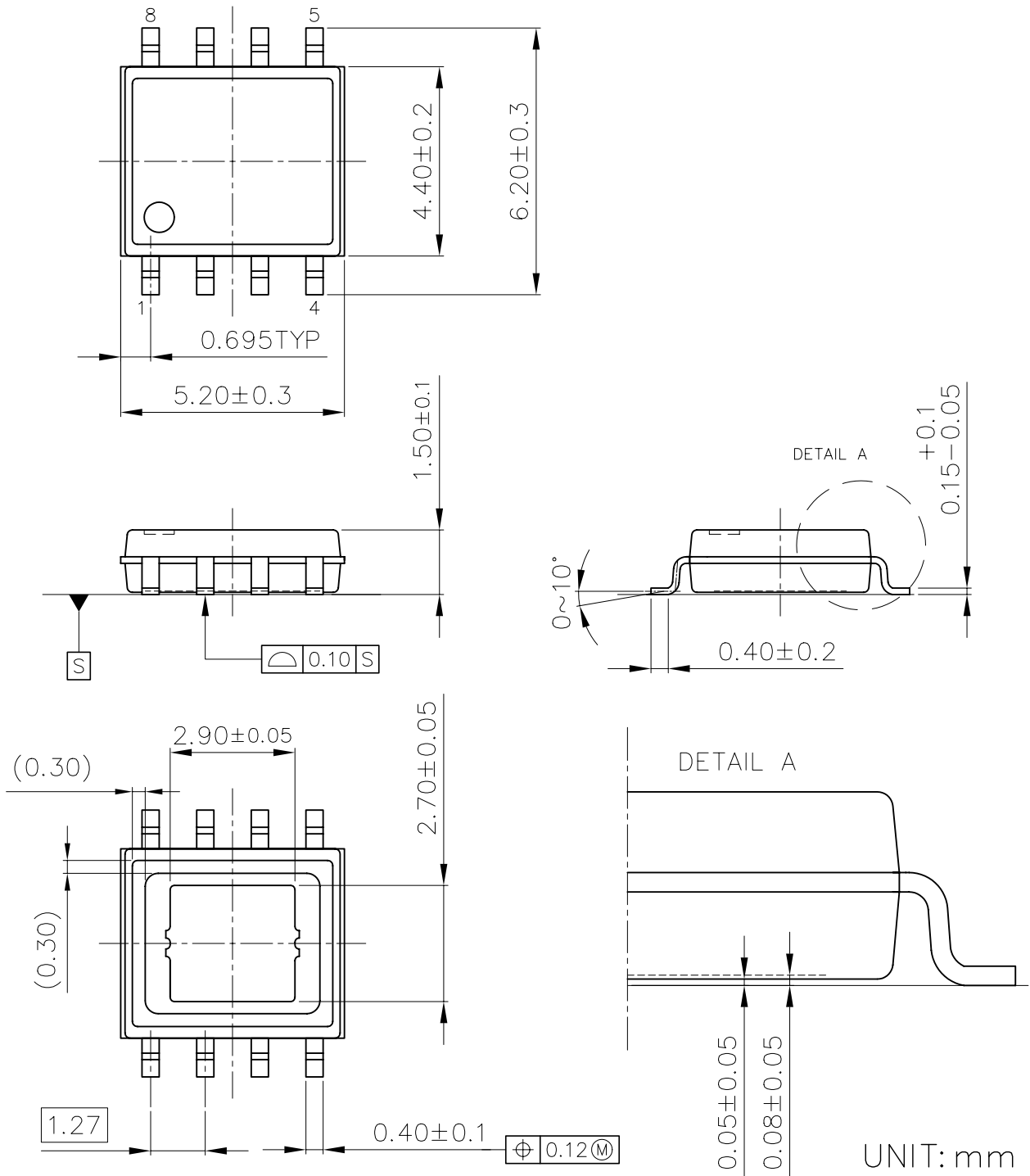

HSOP-8E Package Dimensions





1. The products and the product specifications described in this document are subject to change or discontinuation of production without notice for reasons such as improvement. Therefore, before deciding to use the products, please refer to Ricoh sales representatives for the latest information thereon.
2. The materials in this document may not be copied or otherwise reproduced in whole or in part without prior written consent of Ricoh.
3. Please be sure to take any necessary formalities under relevant laws or regulations before exporting or otherwise taking out of your country the products or the technical information described herein.
4. The technical information described in this document shows typical characteristics of and example application circuits for the products. The release of such information is not to be construed as a warranty of or a grant of license under Ricoh's or any third party's intellectual property rights or any other rights.
5. The products in this document are designed for automotive applications. However, when using the products for automotive applications, please make sure to contact Ricoh sales representative in advance due to confirming the quality level.
6. We are making our continuous effort to improve the quality and reliability of our products, but semiconductor products are likely to fail with certain probability. In order to prevent any injury to persons or damages to property resulting from such failure, customers should be careful enough to incorporate safety measures in their design, such as redundancy feature, fire containment feature and fail-safe feature. We do not assume any liability or responsibility for any loss or damage arising from misuse or inappropriate use of the products.
7. Anti-radiation design is not implemented in the products described in this document.
8. The X-ray exposure can influence functions and characteristics of the products. Confirm the product functions and characteristics in the evaluation stage.
9. WLCSP products should be used in light shielded environments. The light exposure can influence functions and characteristics of the products under operation or storage.
10. There can be variation in the marking when different AOI (Automated Optical Inspection) equipment is used. In the case of recognizing the marking characteristic with AOI, please contact Ricoh sales or our distributor before attempting to use AOI.
11. Please contact Ricoh sales representatives should you have any questions or comments concerning the products or the technical information.



**Ricoh is committed to reducing the environmental loading materials in electrical devices with a view to contributing to the protection of human health and the environment.**

Ricoh has been providing RoHS compliant products since April 1, 2006 and Halogen-free products since April 1, 2012.

**RICOH** RICOH ELECTRONIC DEVICES CO., LTD.

<https://www.e-devices.ricoh.co.jp/en/>

#### Sales & Support Offices

##### **Ricoh Electronic Devices Co., Ltd.**

##### **Shin-Yokohama Office (International Sales)**

2-3, Shin-Yokohama 3-chome, Kohoku-ku, Yokohama-shi, Kanagawa, 222-8530, Japan  
Phone: +81-50-3814-7687 Fax: +81-45-474-0074

##### **Ricoh Americas Holdings, Inc.**

675 Campbell Technology Parkway, Suite 200 Campbell, CA 95008, U.S.A.  
Phone: +1-408-610-3105

##### **Ricoh Europe (Netherlands) B.V.**

##### **Semiconductor Support Centre**

Prof. W.H. Keesomlaan 1, 1183 DJ Amstelveen, The Netherlands  
Phone: +31-20-5474-309

##### **Ricoh International B.V. - German Branch**

##### **Semiconductor Sales and Support Centre**

Oberrather Strasse 6, 40472 Düsseldorf, Germany  
Phone: +49-211-6546-0

##### **Ricoh Electronic Devices Korea Co., Ltd.**

3F, Haesung Bldg, 504, Teheran-ro, Gangnam-gu, Seoul, 135-725, Korea  
Phone: +82-2-2135-5700 Fax: +82-2-2051-5713

##### **Ricoh Electronic Devices Shanghai Co., Ltd.**

Room 403, No.2 Building, No.690 Bibo Road, Pu Dong New District, Shanghai 201203,  
People's Republic of China  
Phone: +86-21-5027-3200 Fax: +86-21-5027-3299

##### **Ricoh Electronic Devices Shanghai Co., Ltd. Shenzhen Branch**

1205, Block D (Jinlong Building), Kingkey 100, Hongbao Road, Luohu District,  
Shenzhen, China  
Phone: +86-755-8348-7600 Ext 225

##### **Ricoh Electronic Devices Co., Ltd.**

##### **Taipei office**

Room 109, 10F-1, No.51, Hengyang Rd., Taipei City, Taiwan  
Phone: +886-2-2313-1621/1622 Fax: +886-2-2313-1623