

SHARP

OPTO-ANALOG DEVICES DIVISION
ELECTRONIC COMPONENTS GROUP
SHARP CORPORATION

SPECIFICATION

DEVICE SPECIFICATION FOR

SOLID STATE RELAY

MODEL No.

R3BMF5

(Business dealing name : PR3BMF51NSKF)

Specified for

Enclosed please find copies of the Specifications which consists of 11 pages including cover.
This specification sheets and attached sheets shall be both side copy.
After confirmation of the contents, please be sure to send back copies of the Specifications
with approving signature on each.

CUSTOMER'S APPROVAL

DATE

BY

PRESENTED

DATE

Feb. 14, 2007

BY

H. Imanaka

H. Imanaka,
Department General Manager of
Engineering Dept.,II
Opto-Analog Devices Div.
ELECOM Group
SHARP CORPORATION



Product name : SOLID STATE RELAY

Model No. : R3BMF5

(Business dealing name : PR3BMF51NSKF)

1. These specification sheets include materials protected under copyright of Sharp Corporation ("Sharp"). Please do not reproduce or cause anyone to reproduce them without Sharp's consent.
2. When using this product, please observe the absolute maximum ratings and the instructions for use outlined in these specification sheets, as well as the precautions mentioned below. Sharp assumes no responsibility for any damage resulting from use of the product which does not comply with the absolute maximum ratings and the instructions included in these specification sheets, and the precautions mentioned below.

(Precautions)

- (1) This product is designed for use in the following application areas ;

· OA equipment	Audio visual equipment	· Home appliances	}
· Telecommunication equipment (Terminal)	· Measuring equipment		
· Tooling machines	· Computers		

If the use of the product in the above application areas is for equipment listed in paragraphs (2) or (3), please be sure to observe the precautions given in those respective paragraphs.
 - (2) Appropriate measures, such as fail-safe design and redundant design considering the safety design of the overall system and equipment, should be taken to ensure reliability and safety when this product is used for equipment which demands high reliability and safety in function and precision, such as ;

· Transportation control and safety equipment (aircraft, train, automobile etc.)	}		
· Traffic signals		· Gas leakage sensor breakers	· Rescue and security equipment
· Other safety equipment			
 - (3) Please do not use this product for equipment which require extremely high reliability and safety in function and precision, such as ;

· Space equipment	· Telecommunication equipment (for trunk lines)	}
· Nuclear power control equipment	· Medical equipment	
 - (4) Please contact and consult with a Sharp sales representative if there are any questions regarding interpretation of the above three paragraphs.
3. Please contact and consult with a Sharp sales representative for any questions about this product.



1. Application

This specification applies to the outline and characteristics of Solid State Relay (SSR), Model No. R3BMF5 (Apply line voltage 200V AC).

2. Outline

Refer to the attached sheet, page 4.

3. Ratings and characteristics

Refer to the attached sheet, page 5 to 6

4. Reliability

Refer to the attached sheet, page 7.

5. Outgoing inspection

Refer to the attached sheet, page 8.

6. Supplement

6.1 Business dealing name

The business dealing name used for this product when ordered or delivered shall be PR3BMF51NSKF.

6.2 Package specification

Refer to the attached sheet, page 9 to 10.

6.3 Isolation voltage shall be measured in the following method.

- (1) Short between anode and cathode on the primary side and between anode, cathode and gate on the secondary side.
- (2) The dielectric withstanding tester with zero-cross circuit shall be used.
- (3) The wave form of applied voltage shall be a sine wave.

(It is recommended that the isolation voltage be measured in insulation oil.)

6.4 This Model is approved by UL and CSA.

Approved Model No. : R3BMF5

1. UL file No. : E94758
2. CSA file No. : LR63705

CSA approved mark "" and rating shall be indicated on minimum unit package.

6.5 This product is not designed against irradiation.

This product is assembled with electrical input and output.

This product incorporates non-coherent light emitting diode.

6.6 ODS materials

This product shall not contain the following materials.

Also, the following materials shall not be used in the production process for this product.

Materials for ODS : CFCs, Halon, Carbon tetrachloride, 1.1.1-Trichloroethane (Methyl chloroform)

6.7 Brominated flame retardants

Specified brominated flame retardants (PBB and PBDE) are not used in this device at all.

REFERENCE

- 6.8 This product complies with RoHS directive.
 Object: mercury, lead^{*)}, cadmium, hexavalent chromium, polybrominated biphenyls and polybrominated diphenyl ethers
 *) In accordance with RoHS directive, except the lead in high melting point solder (Containing more than 85%).

7. Notes

7.1 Circuit designing

(1) Trigger current

The LED used in the Solid state relay generally decreases the light emission power by operation. In case of long operation time, please decide I_F value so that I_F is twice or more of the Maximum value of the Minimum triggering current at circuit design with considering the decreases of the light emission power of the LED. (50%/5years)

(2) Snubber circuit

This device doesn't have built-in snubber circuit.

To avoid the false operation and protect SSR, please locate the appropriate snubber circuit between output pins base by the load. (Recommendable values : $R_s=47\Omega$, $C_s=0.022\mu F$)

Particularly, in case the device is used for the load such as solenoid valves and motors, false operation may happen in off-state due to rapid change of voltage at output pins caused by the phase difference of load current.

So please be sure to locate the snubber circuit ($R_s=47\Omega$, $C_s=0.022\mu F$) and make sure the device works properly in actual conditions.

In addition, the values of snubber circuit may have to be changed if necessary after tested in actual conditions.

(3) Off-state input current

Input current (I_F) at off-state shall be set 0.1mA or less.

(4) Pulse drive

In case that pulse drive is carried out, the pulse width of input signal should be 1ms or more.

(5) If the voltage exceeding the repetitive peak off-state voltage (V_{DRM}) in the absolute maximum ratings is applied to the phototriac, it may cause not only faulty operation but breakdown.

Make sure that the surge voltage exceeding V_{DRM} shall not be applied by using the varistor, CR.

7.2 Ccleaning

(1) Solvent cleaning : Solvent temperature 45°C or less Immersion for 3 min or less

(2) Ultrasonic cleaning : The effect to device by ultrasonic cleaning differs by cleaning bath size, ultrasonic power output, cleaning time, PCB size or device mounting condition etc.

Please test it in actual using condition and confirm that any defect doesn't occur before starting the ultrasonic cleaning.

(3) Applicable solvent : Ethyl alcohol, Methyl alcohol, Isopropyl alcohol

In case the other solvent is used, there are cases that the packaging resin is eroded.

Please use the other solvent after thorough confirmation is performed in actual using condition.

7.3 Using method

As to this product, all pin shall be used by soldering on the print wiring board. (Socket and others shall not be used.)

7.4 Precautions for Soldering

(1) In case of flow soldering (Avoid immersing the resin part in the solder.)

It is recommended that flow soldering be carried out at 270°C or less and within 10s

(Pre-heating: 100 to 150°C, 30 to 80s) : Within 2 times

(2) In case of hand soldering

It is recommended that hand soldering be carried out at 400°C or less and within 3s: Within 2 times

(3) Other precautions

Depending on equipment and soldering conditions (temperature, Using solder etc.), the effect to junction between PCB and lead pins of the device is different.

Please confirm that there is no problem on the actual use conditions

REFERENCE

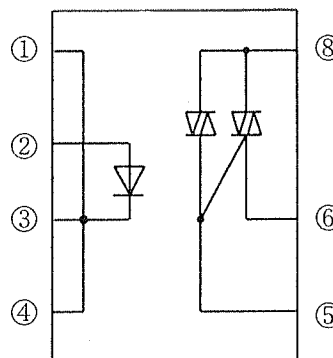
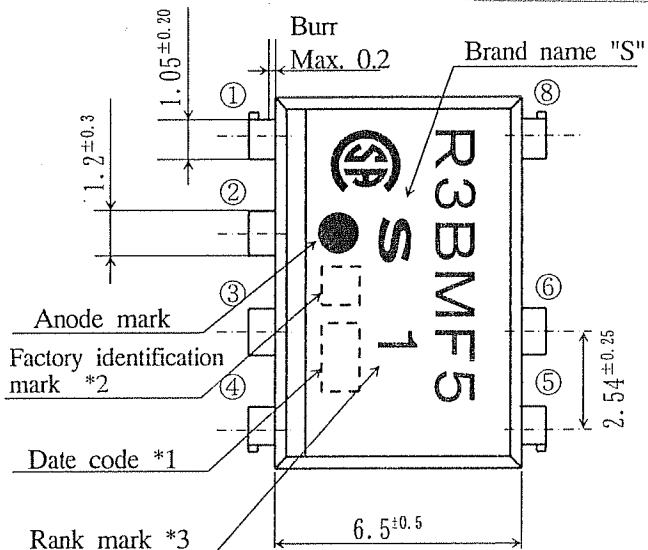

Pin-Number and internal connection diagram

- ② : Anode
- ①③④ : Cathode
- ⑧ : T_2
- ⑥ : T_1
- ⑤ : Gate

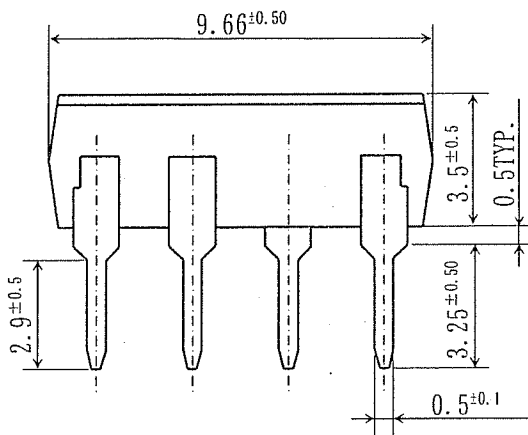
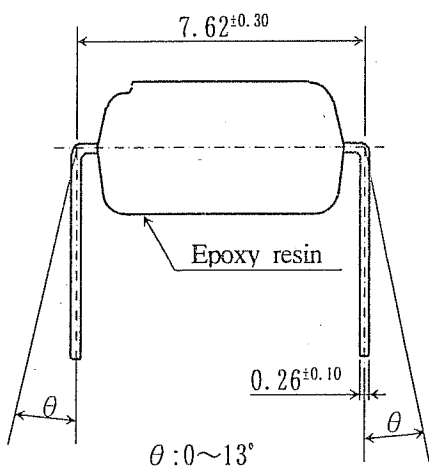

Marking is laser marking

- *1) 2-digit number shall be marked according to OLD DIN standard.
- *2) Factory identification mark shall be or shall not be marked.
- *3) Rank mark is marked under the 'F' of Model No.
- *4) Pin material : Copper Alloy
Pin finish : SnCu plating (Cu : TYP. 2%)

Product mass : Approx. 0.56g

UNIT : 1/1 mm	
Name	R3BMF5 Outline Dimensions (Business dealing name : PR3BMF51NSKF)

3. Ratings and characteristics

3.1 Absolute maximum ratings

Ta=25°C

Parameter		Symbol	Rating	Unit
Input	Forward current *1	I _F	50	mA
	Reverse voltage	V _R	6	V
Output	RMS on-state current *1	I _{T(rms)}	1.2	A
	Peak one cycle surge current	I _{surge}	12(50Hz sine wave)	A
	Repetitive peak off-state voltage	V _{DRM}	600	V
Isolation voltage *2		Viso(rms)	4.0	kV
Operating temperature		T _{opr}	-30 to +85	°C
Storage temperature		T _{stg}	-40 to +125	°C
Soldering temperature		T _{sol}	270 (For 10s)	°C

*1 The derating factors of absolute maximum rating due to ambient temperature are shown in Fig.1, 2.

*2 AC for 1min, 40 to 60%RH, f=60Hz

3.2 Electrical characteristics

Ta=25°C

Parameter		Symbol	MIN.	TYP.	MAX.	Unit	Conditions
Input	Forward voltage	V _F	-	1.2	1.4	V	I _F =20mA
	Reverse current	I _R	-	-	10	μA	V _R =3V
Output	Repetitive peak off-state current	I _{DRM}	-	-	100	μA	V _D =V _{DRM}
	On-state voltage	V _T	-	-	2.5	V	I _T =1.2A
	Holding current	I _H	-	-	25	mA	V _D =6V
	Critical rate of rise of off-state voltage	dv/dt	100	-	-	V/μs	V _D =1/√2 · V _{DRM}
Transfer characteristics	Minimum trigger current	I _{FT}	-	-	10	mA	V _D =6V, R _L =100Ω
	Isolation resistance	R _{ISO}	5×10 ¹⁰	10 ¹¹	-	Ω	DC500V 40 to 60%RH
	Turn on time	t _{ON}	-	-	100	μs	V _D =6V, R _L =100Ω, I _F =20mA

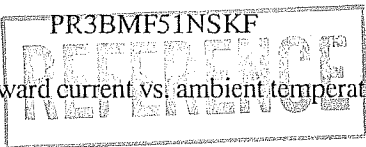

Fig.1 Forward current vs. ambient temperature(*1)

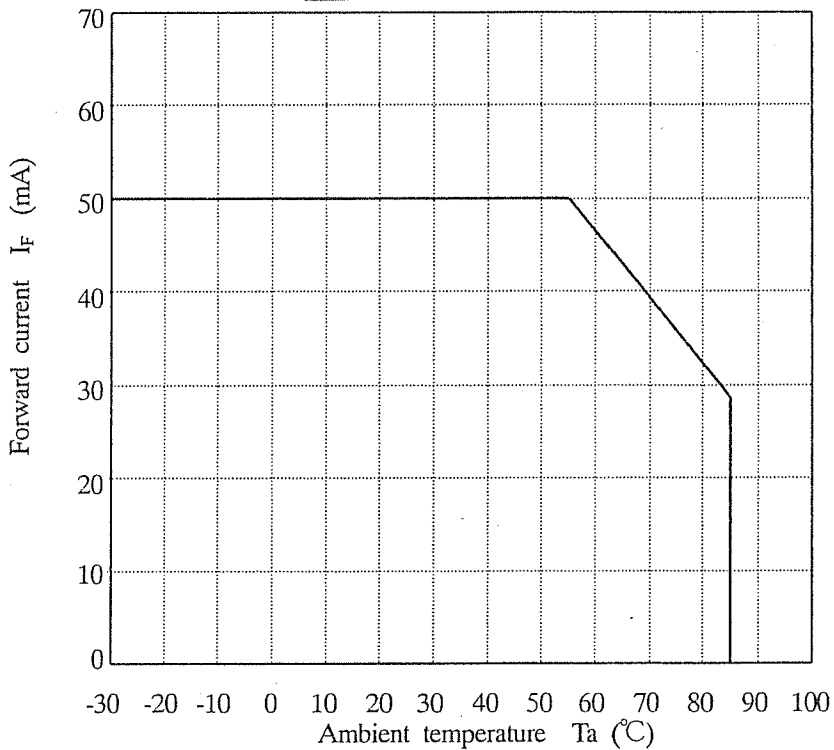
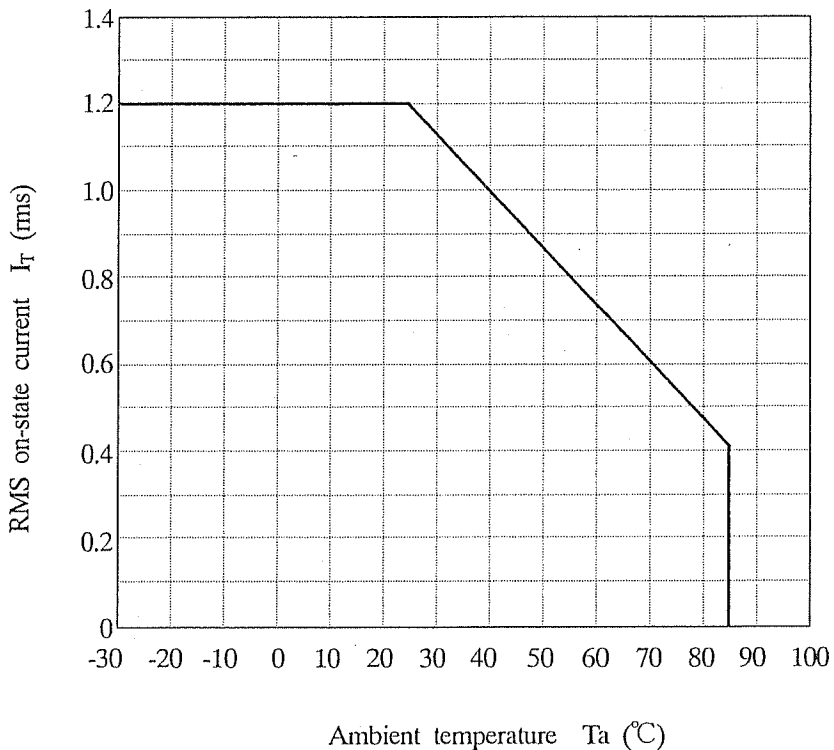

Fig.2 RMS on-state current vs. ambient temperature(*1)



*1 Mounting conditions
 No heat sink
 Paper phenol board : 100mm×100mm×1.6mm
 All pins should be installed in the print board with soldering.
 Whole solder landing dimensions : 140mm²

4. Reliability

The reliability of products shall satisfy items listed below.

Confidence level : 90%
LTPD : 10 or 20

Test Items	Test Conditions *1	Failure Judgement Criteria	Samples (n)
			Defective(C)
Solderability *2	245±3°C, 5s	—	n=11, C=0
Soldering heat *3	(Flow soldering) 270°C, 10 s	$V_F > U \times 1.2$ $V_T > U \times 1.2$ $I_{FT} > U \times 1.3$ $I_R > U \times 2.0$ $I_{DRM} > U \times 2.0$ U : Upper specification limit	n=11, C=0
	(Soldering by hand) 400°C, 3 s		n=11, C=0
Terminal strength (Tension)	Weight : 5N 5 s/each terminal		n=11, C=0
Terminal strength (Bending) *4	Weight : 2.5N 2 times/each terminal		n=11, C=0
Mechanical shock	15km/s ² , 0.5ms 3 times/±X, ±Y, ±Z direction		n=11, C=0
Variable frequency vibration	100 to 2000 to 100Hz/4min 200m/s ² 4 times/ X, Y, Z direction		n=11, C=0
Temperature cycling	1 cycle -40°C to +125°C (30min) (30min) 20 cycles test, Without Road		n=22, C=0
High temp. and high humidity storage	+60°C, 90%RH, 500h		n=22, C=0
High temp. storage	+125°C, 1000h		n=22, C=0
Low temp. storage	-40°C, 1000h		n=22, C=0
Operation life	I _F =50mA, I _T (rms)=1.2A T _a =25°C, 1000h	n=22, C=0	

*1 Test method, conforms to EIAJ ED 4701.

*2 Solder shall adhere at the area of 95% or more of immersed portion of lead, and pin hole or other holes shall not be concentrated on one portion.

*3 The lead pin depth dipped into solder shall be 1.0mm away from the package edge.

*4 Terminal bending direction is shown below.

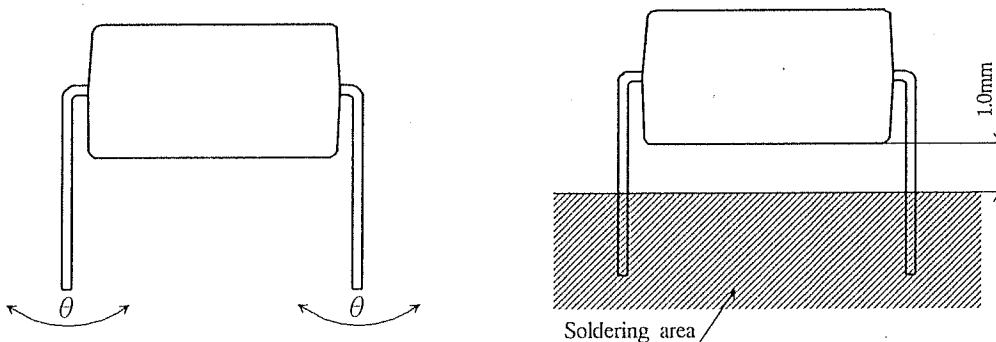

REFERENCE

5. Outgoing inspection

5.1 Inspection items

(1) Electrical characteristics

 $V_F, I_R, I_{DRM}, V_T, I_{FT}, R_{ISO}, V_{ISO}$

(2) Appearance

5.2 Sampling method and Inspection level

A single sampling plan, normal inspection level II based on ISO 2859 is applied.
The AQL according to the inspection items are shown below.

Defect	Inspection item	AQL (%)
Major defect	Electrical characteristics Unreadable marking	0.065
Minor defect	Appearance defect except the above mentioned.	0.25

6.2 Package specification

6.2.1 Package materials

No.	Name	Materials	Purposes
1	Sleeve	HIPS with preventing static electricity	Products packaged
2	Stopper	Styrene-Elastomer	Products fixed
3	Packaging case	Corrugated cardboard	Sleeve packaged
4	Kraft tape	Paper	Lid of packaged case fixed
5	Label	Paper	Model No.(Business dealing name),lot No. quantity , country of origin ,Company name and inspection date specified

6.2.2 Package method

- (1) MAX. 50pcs. of products shall be packaged in a sleeve and both of sleeve edges shall be fixed by stoppers.
- (2) MAX. 20 sleeves above shall be packaged in a packing case.
- (3) The label shall be put on the side of the packaging case.
- (4) Case shall be closed with the lid and enclosed with kraft tape.

6.2.3 Sleeve outline dimensions

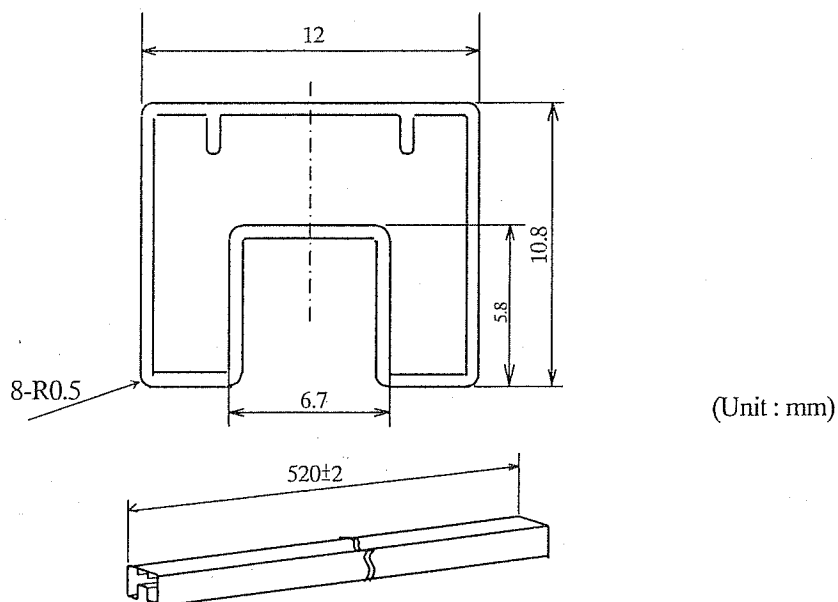

- Note 1) Thickness : 0.5 ± 0.2 mm
 2) Process with applying antistatic treatment.
 3) Unless otherwise specified tolerances shall be ± 0.5 mm.
 (However except for deformation due to the rubber stopper in sleeve.)

6.2.4 Packaging case outline dimensions

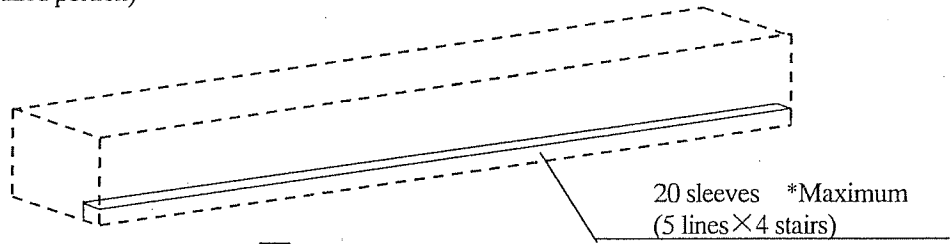
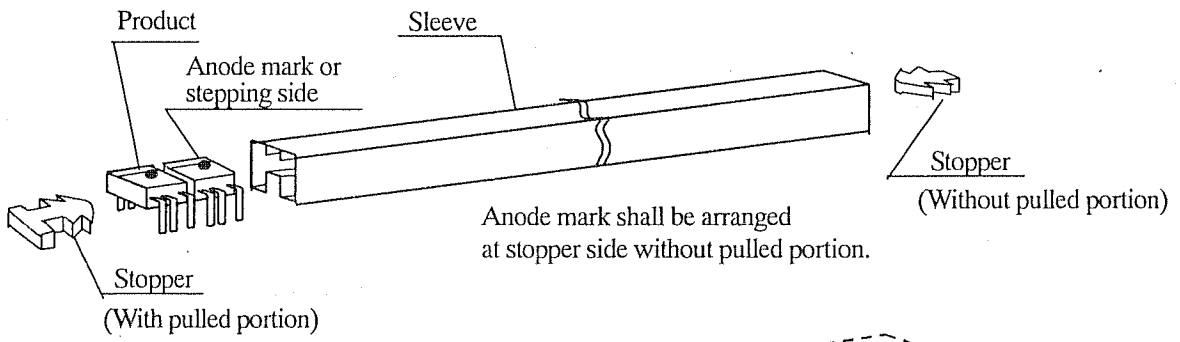

It is impossible to mix different model or different rank model in one case.

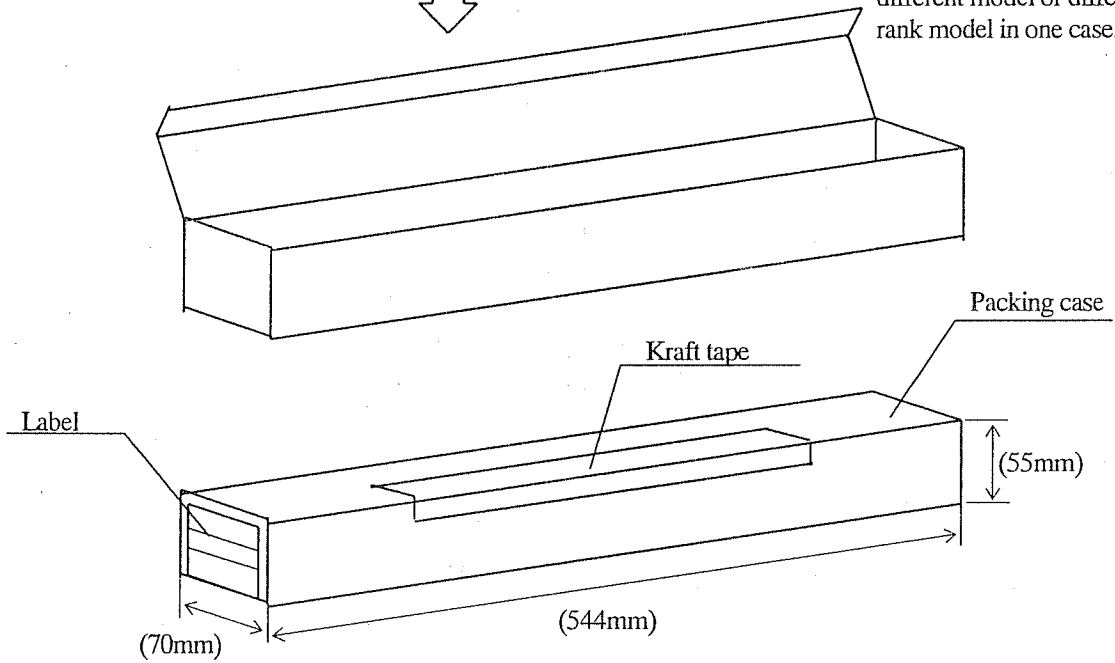

Regular packing mass: Approx. 970g

() : Reference dimensions