

S-1 Spectral Response(QE 0.05% at 1.06 μm <R632-01>) 19mm(3/4 Inch) Diameter, 10-stage, Head-On Type

GENERAL

Parameter		Description/Value	Unit
Spectral Response		400 to 1200	nm
Wavelength of Maximum Response		800	nm
Photocathode	Material	Ag-O-Cs	-
	Minimum Effective Area	15	mm dia.
Window Material		Borosilicate glass	-
Dynode	Structure	Linear focused	-
	Number of Stages	10	-
Base		12-pin glass base	-
Suitable Socket		E678-12L(supplied)	-

MAXIMUM RATINGS (Absolute Maximum Values)

Parameter		Value	Unit
Supply Voltage	Between Anode and Cathode	1500	Vdc
	Between Anode and Last Dynode	250	Vdc
Average Anode Current		0.01	mA
Ambient Temperature		-80 to +50	$^{\circ}\text{C}$

CHARACTERISTICS (at 25 $^{\circ}\text{C}$)

Parameter		Min.	Typ.	Max.	Unit	
Cathode Sensitivity	Luminous(2856K)	10	20	-	$\mu\text{A}/\text{lm}$	
	Radiant at 800nm	-	1.9	-	mA/W	
	Red/White Ratio (with Toshiba IR-D80A)	R632	-	0.1	-	-
		R632-01	-	0.14	-	-
	Quantum Efficiency at 1.06 μm	R632	-	0.02	-	%
R632-01		-	0.05	-	%	
Anode Sensitivity	Luminous(2856K)	5	10	-	A/lm	
	Radiant at 800nm	-	950	-	A/W	
Gain		-	5×10^5	-	-	
Anode Dark Current(at 4A/lm)	R632	-	150	500	nA	
	R632-01	-	800	2000	nA	
Time Response	Anode Pulse Rise Time	-	2.2	-	ns	
	Electron Transit Time	-	25	-	ns	

NOTE: Anode characteristics are measured with the voltage distribution ratio shown below.

VOLTAGE DISTRIBUTION RATIO AND SUPPLY VOLTAGE

Electrode	K	Dy1	Dy2	Dy3	Dy4	Dy5	Dy6	Dy7	Dy8	Dy9	Dy10	P
Ratio	1.5	1	1	1	1	1	1	1	1	1	1	

Supply Voltage : 1250Vdc, K:Cathode, Dy:Dynode, P:Anode

Subject to local technical requirements and regulations, availability of products included in this promotional material may vary. Please consult with our sales office.

Information furnished by HAMAMATSU is believed to be reliable. However, no responsibility is assumed for possible inaccuracies or commission. Specifications are subjected to change without notice. No patent right are granted to any of the circuits described herein. © 1996 Hamamatsu Photonics K.K.

PHOTOMULTIPLIER TUBES R632, R632-01

Figure 1: Typical Spectral Response

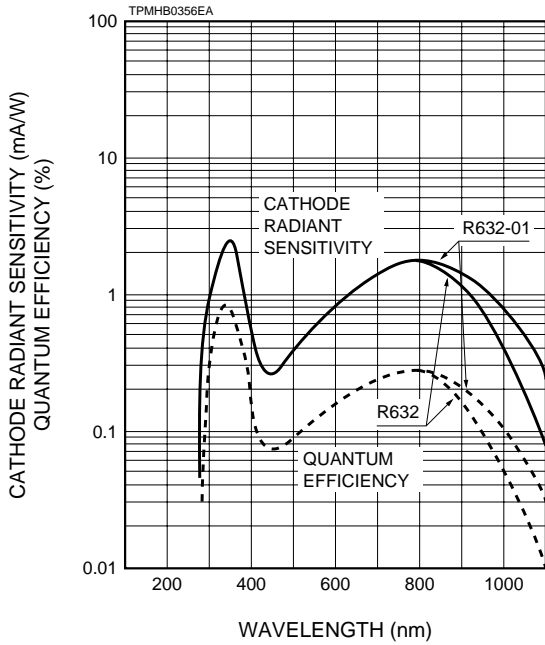

Figure 2: Typical Gain and Anode Dark Current

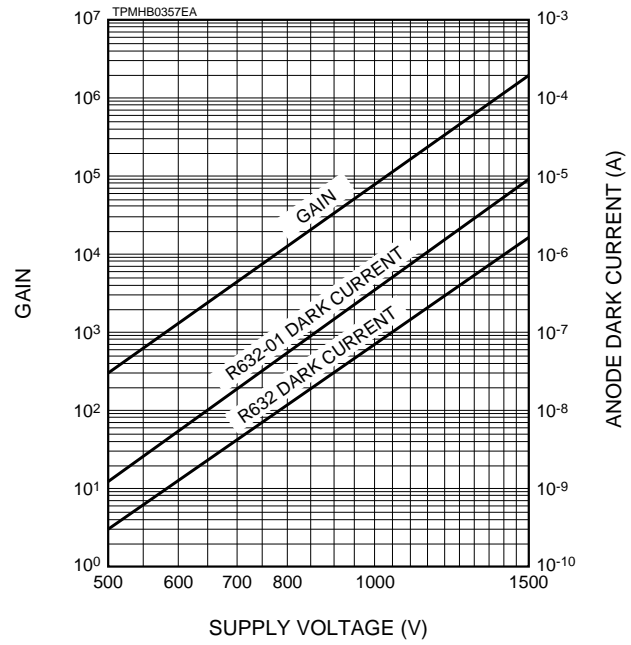

Figure 3: Typical Temperature Characteristics of Dark Current

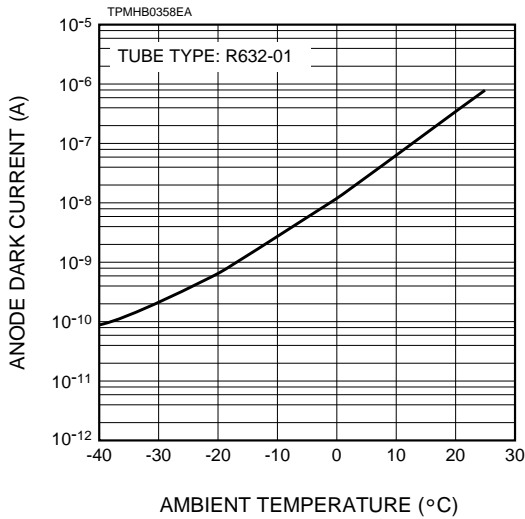
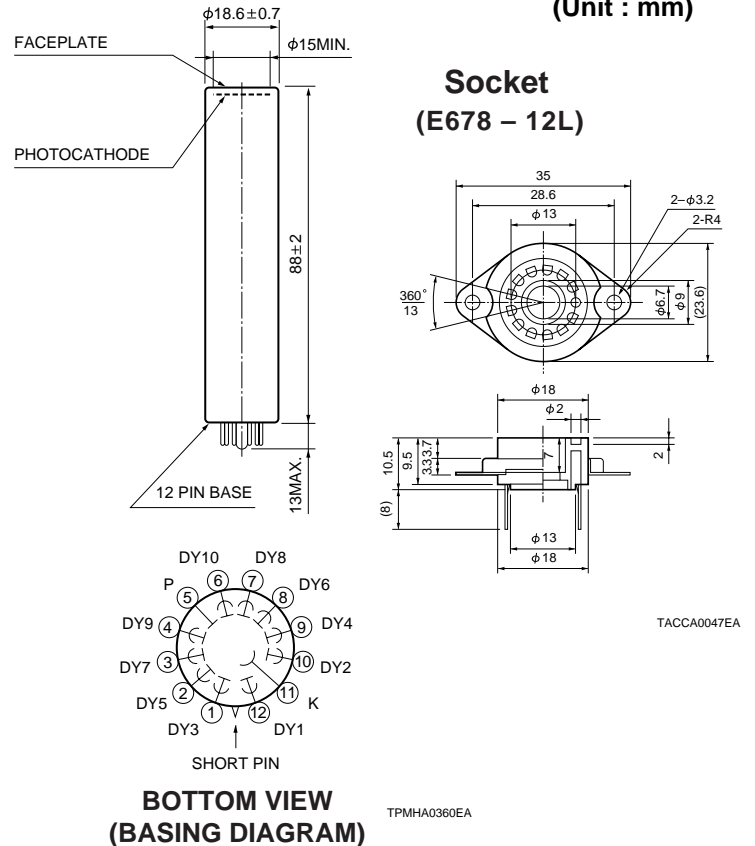

Figure 4: Dimensional Outline and Basing Diagram (Unit : mm)



HAMAMATSU

HAMAMATSU PHOTONICS K.K., Electron Tube Center

314-5, Shimokanzo, Toyooka-village, Iwata-gun, Shizuoka-ken, 438-0193, Japan, Telephone: (81)539/62-5248, Fax: (81)539/62-2205

U.S.A.: Hamamatsu Corporation: 360 Foothill Road, Bridgewater, N.J. 08807-0910, U.S.A., Telephone: (1)908-231-0960, Fax: (1)908-231-1218

Germany: Hamamatsu Photonics Deutschland GmbH: Arzbergerstr. 10, D-82211 Herrsching am Ammersee, Germany, Telephone: (49)8152-375-0, Fax: (49)8152-2658

France: Hamamatsu Photonics France S.A.R.L.: 8, Rue du Saule Trapu, Parc du Moulin de Massy, 91882 Massy Cedex, France, Telephone: (33)1 69 53 71 00, Fax: (33)1 69 53 71 10

United Kingdom: Hamamatsu Photonics UK Limited: Lough Point, 2 Gladbeck Way, Windmill Hill, Enfield, Middlesex EN2 7JA, United Kingdom, Telephone: (44)181-367-3560, Fax: (44)181-367-6384

North Europe: Hamamatsu Photonics Norden AB: Färögatan 7, S-164-40 Kista Sweden, Telephone: (46)8-703-29-50, Fax: (46)8-750-58-95

Italy: Hamamatsu Photonics Italia: S.R.L.: Via Della Moia, 1/E, 20020 Arese, (Milano), Italy, Telephone: (39)2-935 81 733, Fax: (39)2-935 81 741

TPMH1142E01
FEB. 1996