

DESCRIPTION

R8A66155 is a semiconductor integrated circuit which has 16-bit shift register function to execute serial in - parallel out conversion and parallel in - serial out conversion.

Built in two shift registers for serial in - parallel out and parallel in - serial out are constructed independently, This IC is able to read serial input data into a shift register while output the serial data converting from the parallel data input.

Also, parallel data I/O pins can be set to input mode or output mode by a bit.

R8A66155 is useful in a wide range of applications, such as MCU (micro controller unit) I/O port extension and serial bus system data communication.

Moreover, R8A66155 can be used as the anode common LED drive, too.

FEATURES

- Bi-directional serial communication with MCU
- Serial data can be input during parallel to serial data conversion
- Parallel data I/O pins can be set input mode or output mode by a bit
- Schmitt input (DI, CLK, /S, /CS)
- N-ch open drain output (DO, D1~D16).
High output current I_{OL}=24mA (at V_{CC}=4.5V), I_{OL}=15mA (at V_{CC}=3.0V)
- Parallel data I/O pins (D1~D16)
- Wide supply voltage range (V_{CC}=2.0 to 6.0V)
- Wide operating temperature range (T_a=-40 to 85°C)

APPLICATION

- Serial - parallel or parallel - serial data conversion for MCU peripheral.
- Serial bus control by MCU.
- LED array drive, The various LED display modules.

PIN CONFIGURATION (TOP VIEW)

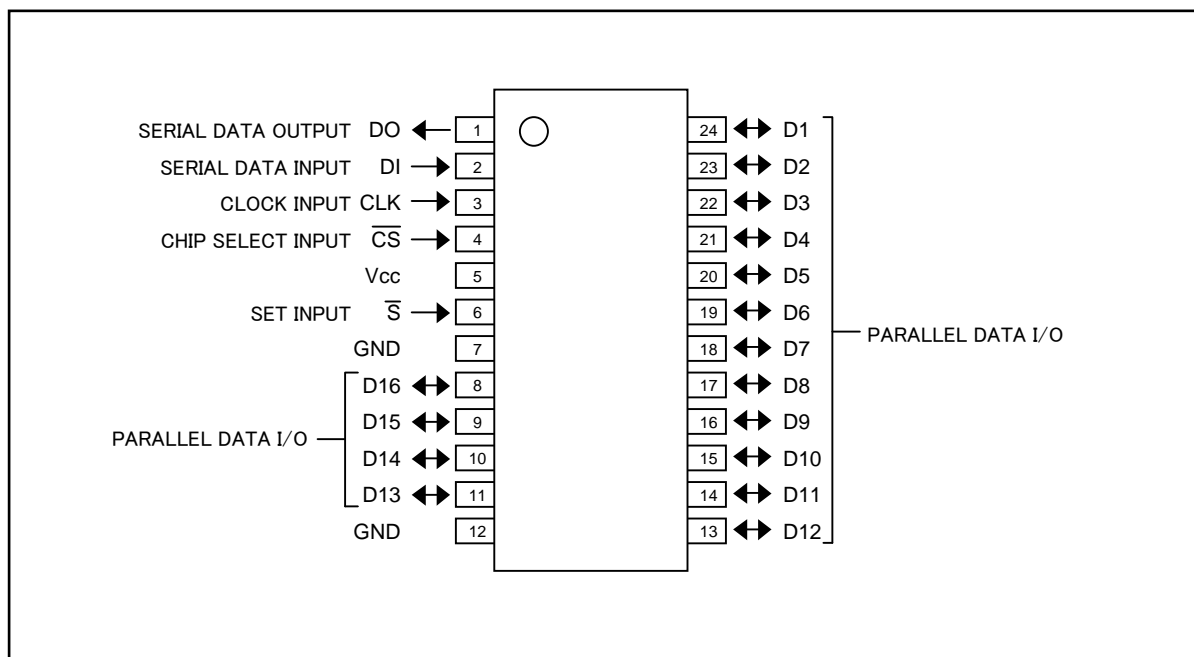

BLOCK DIAGRAM

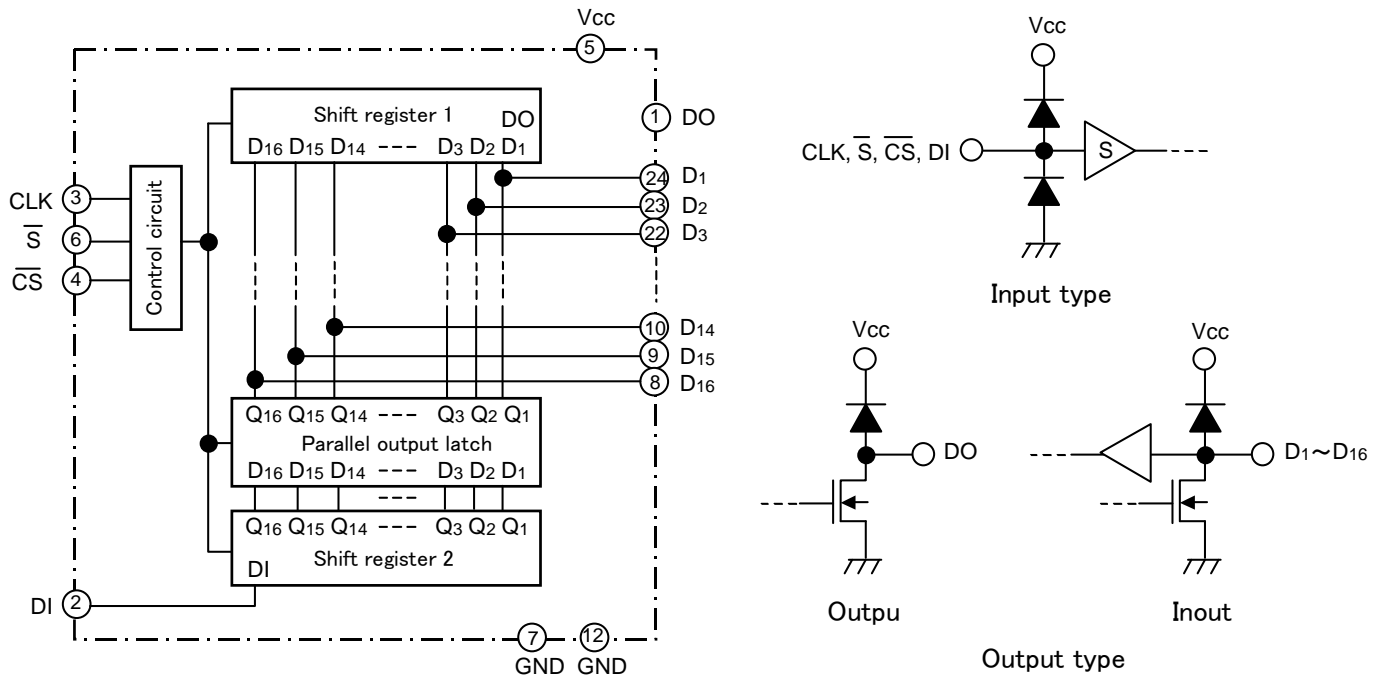

FUNCTION

The R8A66155 is produced by using the silicon gate CMOS technology and has low power dissipation and high noise margin.

Built in two shift registers for serial in-parallel out (Shift register 2) and parallel in-serial out (Shift register 1) are constructed independently, R8A66155 is able to read serial input data into a shift register while output the serial data converting from the parallel data input.

Serial output operation of 16-bit parallel latched data and serial input operation from MCU are started when /CS is changed from "H" to "L".

16-bits parallel data are latched by the negative edge of /CS and are output from the DO terminal synchronously to the negative edge of CLK, and also the DI terminal read serial input data from MCU and are written into the internal shift register 2.

The 17th and following shift clock pulse are ignored and serial input data is masked, and DO terminal becomes high-impedance ("High-Z").

When /CS is changed from "L" to "H", 16-bits serial data which is read from the DI terminal are output to the D1~D16 terminals as parallel data.

As the output circuit type of D1~D16 terminals is N-ch open drain output, write data "H" for pins which should be set to input mode.

DESCRIPTION OF OPERATION

- (1) When power ON, the status of DO and D1~D16 terminals are not determined. These terminals are turn to high-impedance when "L" is input to the /S terminal.
- (2) By the negative edge of /CS, the status of D1~D16 terminals is loaded on shift register 1.
- (3) Synchronous to the negative edge of CLK, 16-bit loaded data is serial output from the DO terminal.
- (4) Synchronous to the positive edge of CLK, 16-bit serial input data from DI is written into the shift register 2.
- (5) The 17th and following shift clock pulse are ignored and the serial data input operation is stopped. And the DO terminal becomes high-impedance ("High-Z").
- (6) By the positive edge of /CS, input data described in (4) is output to D1~D16 terminals.
- (7) Shift register 1 loads the AND tie data of external parallel input data and latched data on parallel output latch.
- (8) If the /CS is changed from "L" to "H" before reaches the 16th bit of CLK, parallel output latch latches data which has been written on shift register 2 and output it to D1~D16 terminals. Serial data after this since is ignored and the DO terminal becomes high-impedance.
- (9) Input/output mode set to D1~D16 terminals is done by the serial input data to the DI terminal. Terminals which "H" is written are set to input, and "L" is written are set to output.

OPERATION TIMING CHART

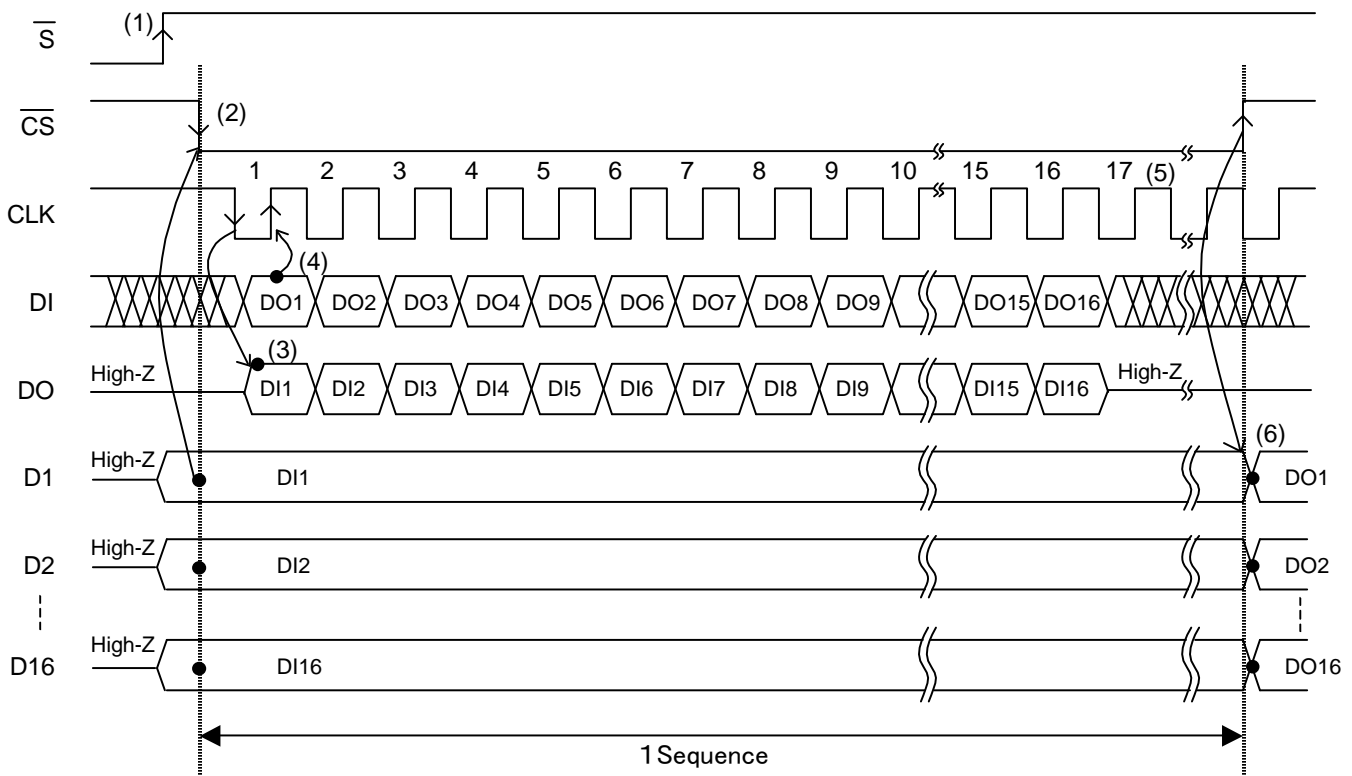

ABSOLUTE MAXIMUM RATINGS (Ta=-40~85°C, unless otherwise noted)

Symbol	Parameter	Conditions	Ratings	Unit
VCC	Supply voltage		-0.5 ~ +7.0	V
VI	Input voltage		-0.5 ~ Vcc+0.5	V
VO	Output voltage		-0.5 ~ Vcc+0.5	V
IO	Output current per output pin		50	mA
ICC	Supply / GND current	VCC, GND	430	mA
Pd	Power dissipation	(Note)	500	mW
Tstg	Storage temperature range		-65 ~ 150	°C

Note: R8A66155SP: Ta=-40~+75°C. Ta=75~85°C are derated at -8 mW/°C.

RECOMMENDED OPERATING CONDITIONS

Symbol	Parameter	Limits			Unit
		Min.	Typ.	Max.	
Vcc	Supply voltage	2.0		6.0	V
VI	Input voltage	0		Vcc	V
VO	Output voltage	0		Vcc	V
Topr	Operating temperature range	-40		85	°C

ELECTRICAL CHARACTERISTICS (Vcc=2.0~6.0V, Ta=-40~85°C, unless otherwise noted)

Symbol	Parameter	Test conditions	Limits			Unit
			Min.	Typ.	Max.	
VT+	Positive going threshold voltage (*1)	Vo=0.1V, Vcc=0.1V I _I I _O =20uA	0.35 x Vcc		0.80 x Vcc	V
VT-	Negative going threshold voltage (*1)		0.20 x Vcc		0.65 x Vcc	V
VIH	"H" input voltage (*2)		0.75 x Vcc			V
VIL	"L" input voltage (*2)				0.25 x Vcc	V
VOL	"L" output voltage	VI=VT+, VT- Vcc=4.5V	IOL=24mA		0.5	V
		VI=VT+, VT- Vcc=3.0V	IOL=15mA		0.5	V
		VI=VT+, VT- Vcc=2.0V	IOL=8mA		0.3	V
IO	Output leakage current	Vcc=6V	Vo=Vcc		10	uA
			Vo=GND		-10	
IIH	"H" input current	VI=Vcc, Vcc=6V			1	uA
IIL	"L" input current	VI=GND, Vcc=6V			-1	
Icc	Quiescent supply current	VI=Vcc, GND Vcc=6V			100	uA

*1 : DI, CLK, /CS, /S

*2 : D1~D16

SWITCHING CHARACTERISTICS

(V_{CC}=2.0~6.0V, T_a=-40~85°C, unless otherwise noted)

Symbol	Parameter	Test conditions	Limits			Unit
			Min.	Typ.	Max.	
f _{max}	Maximum repeat frequency	CL=50pF RL=1kΩ (note1)			1.9	MHz
t _{PLZ}	Output "L-Z" and "Z-L" propagation time				400	ns
t _{PZL}	CLK - DO				400	ns
t _{PLZ}	Output "L-Z" and "Z-L" propagation time				400	ns
t _{PZL}	/CS - D1~D16				400	ns
t _{PLZ}	Output "L-Z" propagation time				400	ns
	/S - DO, /S - D1~D16					

TIMING REQUIREMENTS

(V_{CC}=2.0~6.0V, T_a=-40~85°C, unless otherwise noted)

Symbol	Parameter	Test conditions	Limits			Unit
			Min.	Typ.	Max.	
t _w	CLK, /CS, /S pulse width		260			ns
t _{su}	Setup time of DI to CLK		130			ns
	Setup time of /CS to CLK		130			ns
	Setup time of D1~D16 to /CS		130			ns
t _h	Hold time of DI to CLK		130			ns
	Hold time of /CS to CLK		130			ns
	Hold time of D1~D16 to /CS		130			ns
t _{rec}	Recovery time of /CS to /S		130			ns

NOTE1: TEST CIRCUIT

- (1) The pulse generator (P.G.) has the following characteristics
(10%~90%) t_r=6ns, t_f=6ns, Z_o=50 Ω
- (2) The capacitance CL includes stray wiring capacitance and the probe input capacitance.

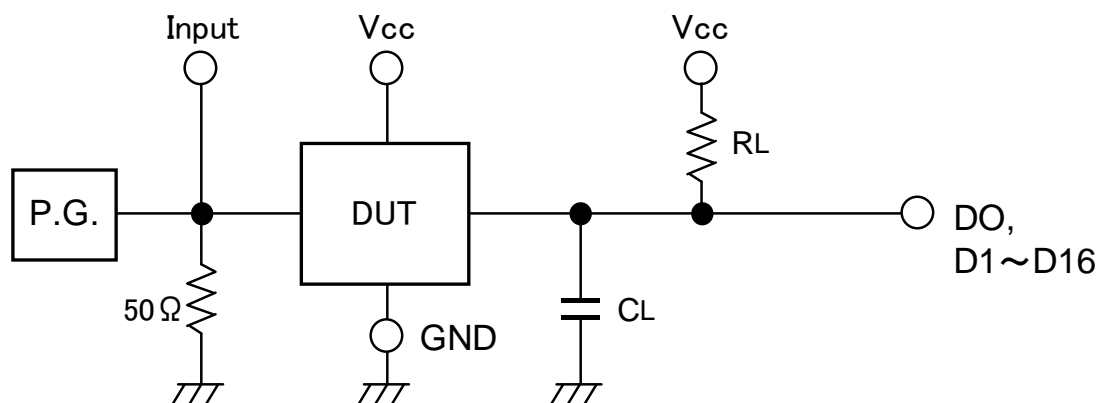

TIMING DIAGRAM

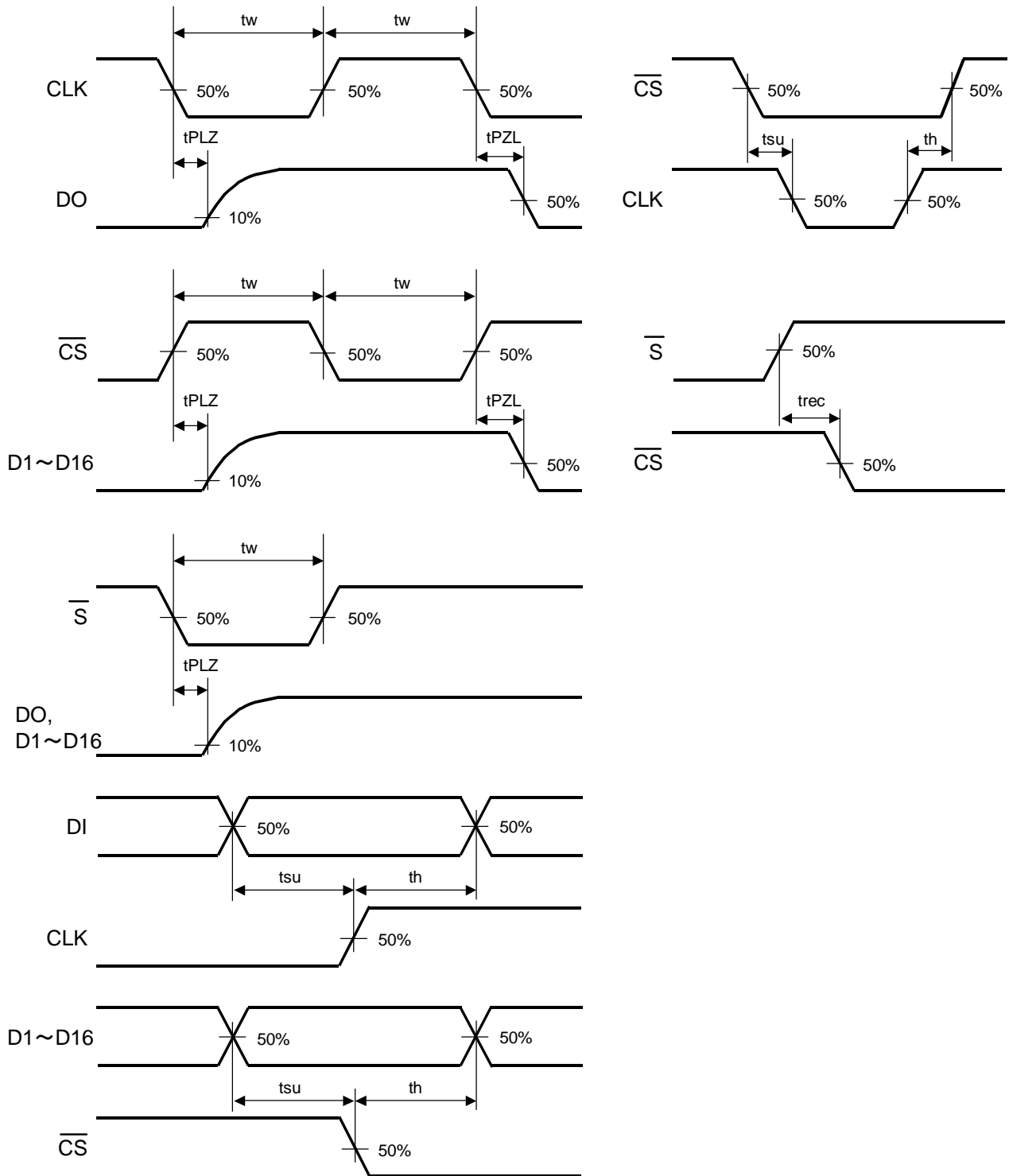

PACKAGE OUTLINE

Package	RENESAS Code	Previous Code
24pin SOP	PRSP0024DF-A	24P2X-B

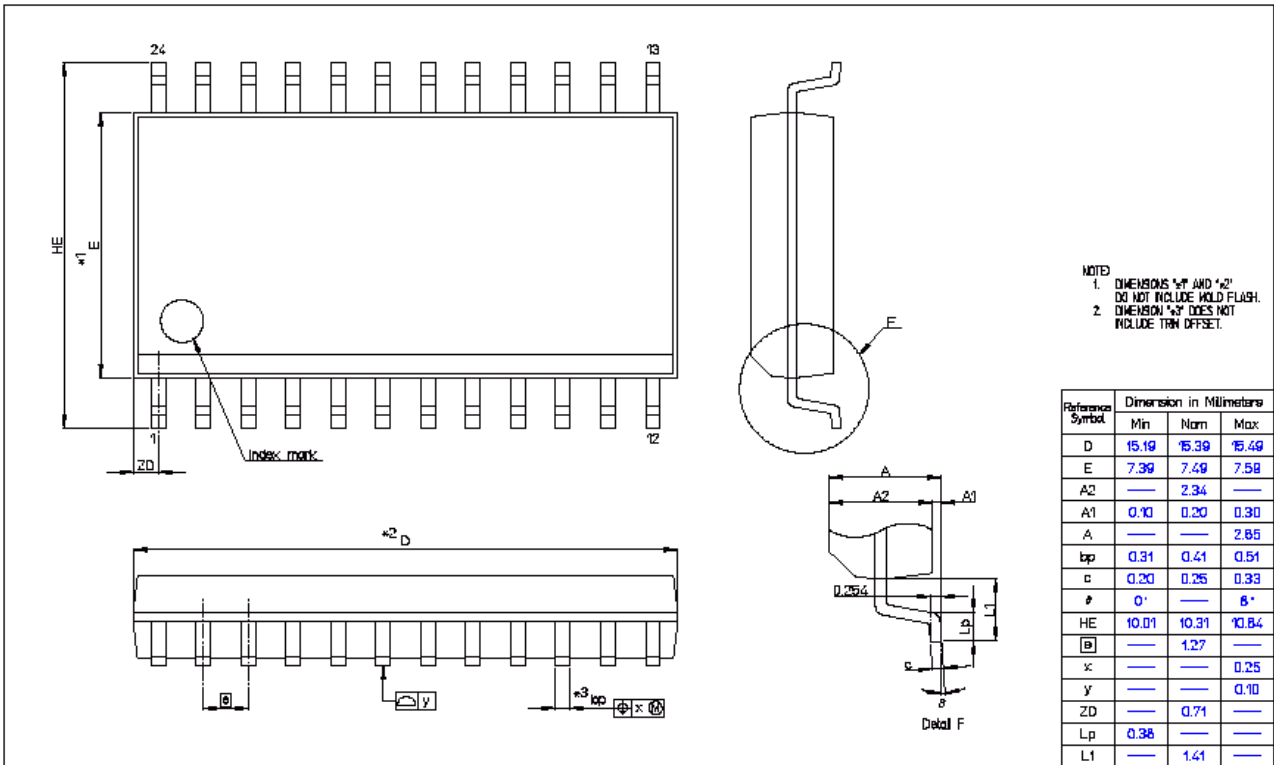

All trademarks and registered trademarks are the property of their respective owners.

Notes:

1. This document is provided for reference purposes only so that Renesas customers may select the appropriate Renesas products for their use. Renesas neither makes warranties or representations with respect to the accuracy or completeness of the information contained in this document nor grants any license to any intellectual property rights or any other rights of Renesas or any third party with respect to the information in this document.
2. Renesas shall have no liability for damages or infringement of any intellectual property or other rights arising out of the use of any information in this document, including, but not limited to, product data, diagrams, charts, programs, algorithms, and application circuit examples.
3. You should not use the products or the technology described in this document for the purpose of military applications such as the development of weapons of mass destruction or for the purpose of any other military use. When exporting the products or technology described herein, you should follow the applicable export control laws and regulations, and procedures required by such laws and regulations.
4. All information included in this document such as product data, diagrams, charts, programs, algorithms, and application circuit examples, is current as of the date this document is issued. Such information, however, is subject to change without any prior notice. Before purchasing or using any Renesas products listed in this document, please confirm the latest product information with a Renesas sales office. Also, please pay regular and careful attention to additional and different information to be disclosed by Renesas such as that disclosed through our website. (<http://www.renesas.com>)
5. Renesas has used reasonable care in compiling the information included in this document, but Renesas assumes no liability whatsoever for any damages incurred as a result of errors or omissions in the information included in this document.
6. When using or otherwise relying on the information in this document, you should evaluate the information in light of the total system before deciding about the applicability of such information to the intended application. Renesas makes no representations, warranties or guarantees regarding the suitability of its products for any particular application and specifically disclaims any liability arising out of the application and use of the information in this document or Renesas products.
7. With the exception of products specified by Renesas as suitable for automobile applications, Renesas products are not designed, manufactured or tested for applications or otherwise in systems the failure or malfunction of which may cause a direct threat to human life or create a risk of human injury or which require especially high quality and reliability such as safety systems, or equipment or systems for transportation and traffic, healthcare, combustion control, aerospace and aeronautics, nuclear power, or undersea communication transmission. If you are considering the use of our products for such purposes, please contact a Renesas sales office beforehand. Renesas shall have no liability for damages arising out of the uses set forth above.
8. Notwithstanding the preceding paragraph, you should not use Renesas products for the purposes listed below:
 - (1) artificial life support devices or systems
 - (2) surgical implantations
 - (3) healthcare intervention (e.g., excision, administration of medication, etc.)
 - (4) any other purposes that pose a direct threat to human lifeRenesas shall have no liability for damages arising out of the uses set forth in the above and purchasers who elect to use Renesas products in any of the foregoing applications shall indemnify and hold harmless Renesas Technology Corp., its affiliated companies and their officers, directors, and employees against any and all damages arising out of such applications.
9. You should use the products described herein within the range specified by Renesas, especially with respect to the maximum rating, operating supply voltage range, movement power voltage range, heat radiation characteristics, installation and other product characteristics. Renesas shall have no liability for malfunctions or damages arising out of the use of Renesas products beyond such specified ranges.
10. Although Renesas endeavors to improve the quality and reliability of its products, IC products have specific characteristics such as the occurrence of failure at a certain rate and malfunctions under certain use conditions. Please be sure to implement safety measures to guard against the possibility of physical injury, and injury or damage caused by fire in the event of the failure of a Renesas product, such as safety design for hardware and software including but not limited to redundancy, fire control and malfunction prevention, appropriate treatment for aging degradation or any other applicable measures. Among others, since the evaluation of microcomputer software alone is very difficult, please evaluate the safety of the final products or system manufactured by you.
11. In case Renesas products listed in this document are detached from the products to which the Renesas products are attached or affixed, the risk of accident such as swallowing by infants and small children is very high. You should implement safety measures so that Renesas products may not be easily detached from your products. Renesas shall have no liability for damages arising out of such detachment.
12. This document may not be reproduced or duplicated, in any form, in whole or in part, without prior written approval from Renesas.
13. Please contact a Renesas sales office if you have any questions regarding the information contained in this document, Renesas semiconductor products, or if you have any other inquiries.



RENESAS SALES OFFICES

<http://www.renesas.com>

Refer to "<http://www.renesas.com/en/network>" for the latest and detailed information.

Renesas Technology America, Inc.
450 Holger Way, San Jose, CA 95134-1368, U.S.A
Tel: <1> (408) 382-7500, Fax: <1> (408) 382-7501

Renesas Technology Europe Limited
Dukes Meadow, Millboard Road, Bourne End, Buckinghamshire, SL8 5FH, U.K.
Tel: <44> (1628) 585-100, Fax: <44> (1628) 585-900

Renesas Technology (Shanghai) Co., Ltd.
Unit 204, 205, AZIACenter, No.1233 Lujiazui Ring Rd, Pudong District, Shanghai, China 200120
Tel: <86> (21) 5877-1818, Fax: <86> (21) 6887-7858/7898

Renesas Technology Hong Kong Ltd.
7th Floor, North Tower, World Finance Centre, Harbour City, Canton Road, Tsimshatsui, Kowloon, Hong Kong
Tel: <852> 2265-6688, Fax: <852> 2377-3473

Renesas Technology Taiwan Co., Ltd.
10th Floor, No.99, Fushing North Road, Taipei, Taiwan
Tel: <886> (2) 2715-2888, Fax: <886> (2) 3518-3399

Renesas Technology Singapore Pte. Ltd.
1 Harbour Front Avenue, #06-10, Keppel Bay Tower, Singapore 098632
Tel: <65> 6213-0200, Fax: <65> 6278-8001

Renesas Technology Korea Co., Ltd.
Kukje Center Bldg. 18th Fl., 191, 2-ka, Hangang-ro, Yongsan-ku, Seoul 140-702, Korea
Tel: <82> (2) 796-3115, Fax: <82> (2) 796-2145

Renesas Technology Malaysia Sdn. Bhd
Unit 906, Block B, Menara Amcorp, Amcorp Trade Centre, No.18, Jln Persiaran Barat, 46050 Petaling Jaya, Selangor Darul Ehsan, Malaysia
Tel: <603> 7955-9390, Fax: <603> 7955-9510