



RA8871L4N

Character/Graphic TFT LCD Controller

Datasheet

March 09, 2016

RAiO Technology Inc.

©Copyright RAiO Technology Inc., 2016

1. Introduction

This is the Hardware Functional Specification for the RA8871 TFT LCD Controller. Including in this document are system block diagrams, Pin information, AC/DC characteristics, each block's function description, detail register descriptions, and power mode control.

1.1 Overview Description

RA8871 is a low-cost color for small and medium size TFT LCD controller, and support 64M-bit external SDRAM memory. The RA8871 supports an 8/16-bit asynchronous parallel host bus while providing high performance bandwidth into the external display memory allowing for fast screen updates. The RA8871 also provides support for multiple display buffers, Picture-in-Picture, Opacity control, and display rotation/mirror ... etc.

1.2 System Diagram & Chip Diagram

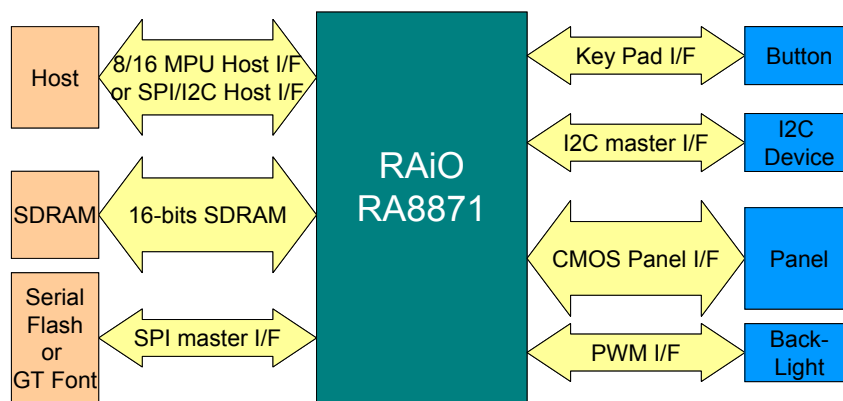

Figure 1-1 : System Diagram

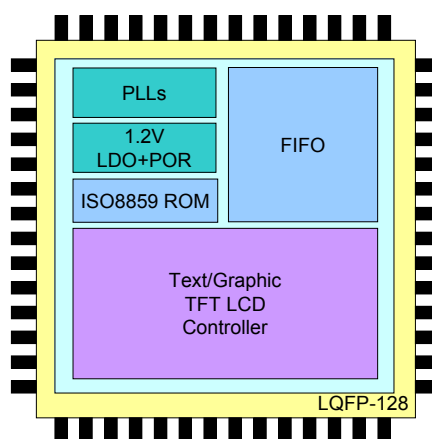

Figure 1-2 : Chip Diagram

2. Features

2.1 Frame Buffer

- Supported SDRAM density:64Mb
- Supported SDRAM configuration: x16
- 16bit SDRAM bus

2.2 Host Interface

- Support 8080/6800 8/16-bit asynchronous parallel bus interface
 - Provide xnwait event to extend MPU cycle
- Support serial host Interface. Ex. IIC, 3/4-wire SPI
- Mirror and rotation functions are available for image data writes.

2.3 Display Input Data Formats

- 1bpp: monochrome data (1-bit/pixel)
- 8bpp: RGB 3:3:2 (1-byte/pixel)
- 16bpp: RGB 5:6:5 (2-byte/pixel)
- 24bpp: RGB 8:8:8 (3-byte/pixel or 4-byte/pixel)
 - Index 2:6 (64 index colors/pixel with opacity attribute)
 - αRGB 4:4:4:4 (4096 colors/pixel with opacity attribute)

2.4 Display Mode

- Configurable digital TFT output: 24-bit TFT output / 18-bit TFT output / 16-bit TFT output

2.5 Support Various Panel Resolution

- Support panel's resolution 320x240,240x320, 480x272,480x320
- Maxim resolution is 480x320x24bit

2.6 Display Features

- Provide 4 User-defined 32x32 pixels Graphic Cursor
- Display Window
The display window is defined by the size of the LCD display. Complete or partial updates to the display window are done through canvas image's setting. The active window size and start position are specified in 8 pixel resolution (horizontal) and 1 line resolution (vertical). Window coordinates are referenced to top left corner of the display window (even when flip is enabled or rotate text, no host side translation is required).
- Picture-in-Picture (PIP) display
Two PIP windows are supported. Enabled PIP windows are always displayed on top of Main window. The PIP windows sizes and start positions are specified in 4 pixel resolution (horizontal) and 1 line resolution (vertical). Image scrolling can be performed by changing the start address of a PIP window. The PIP1 window is always on top of PIP2 window.

- Wake-up display
Wake-up display is available to show the display data quickly which data is stored in SDRAM. This feature is used when returning from the Standby mode or Suspend mode.
- Vertical Flip display
Vertical Flip display functions are available for image data reads. PIP window will be disabled if flip display function enable.
- Color Bar Display
It could display color bar on panel and need not SDRAM. Default resolution is 640 dots by 480 dots.

2.7 Initial Display

- Embed a tiny processor and use to show display data which stored in the serial flash and need not external MPU participate. It will auto execute after power-on, until program execute complete then handover control rights to external MPU. It supports 12 instructions. They are:
 - EXIT: Exit instruction (00h/FFh) -- one byte instruction
 - NOP: NOP instruction (AAh) -- one byte instruction
 - EN4B: Enter 4-Byte mode instruction (B7h) -- one byte instruction
 - EX4B: Exit 4-Byte mode instruction (E9h) -- one byte instruction
 - STSR: Status read instruction (10h) -- two bytes instruction
 - CMDW: Command write instruction (11h) -- two bytes instruction
 - DATR: Data read instruction (12h) -- two bytes instruction
 - DATW: Data write instruction (13h) -- two bytes instruction
 - REPT: Load repeat counter instruction (20h) -- two bytes instruction
 - ATTR: Fetch Attribute instruction (30h) -- two bytes instruction
 - JUMP: Jump instruction (80h) -- five bytes instruction
 - DJNZ: Decrement & Jump instruction (81h) -- five bytes instruction

2.8 Block Transfer Engine (BTE)

- 2D BitBLT Engine
- Copy with ROP & color expansion
- Solid fill & Pattern fill
 - Provide User-defined Patterns with 8x8 pixels or 16x16 pixels
- Opacity (Alpha-Blend) control
It allows two images to be blended to create a new image which can **then** be displayed using a PIP window. The processing speed of Alpha-blend function varies depending on the image size. Optionally, a single input image can be processed.
 - Chroma-keying function: Mixes images with applying the specified RGB color according to transparency rate.
 - Window Alpha-blending function: Mixes two images according to transparency rate in the specified region (fade-in and fade-out functions are available).
 - Dot Alpha-blending function: Mixes images according to transparency rate when the target is a graphics image in the RGB format.

2.9 Geometric Drawing Engine

- Draw dot, Line, Curve, Circle, Ellipse, Triangle, Square & Circular Square

2.10 SPI Master Interface

2.10.1 Text Features

- Embedded 8x16, 12x24, 16x32 Character Sets of ISO/IEC 8859-1/2/4/5.
- Supporting Genitop Inc. UNICODE/BIG5/GB etc. Serial Character ROM with 16x16/24x24/32x32 dots Font Size. The supporting product numbers are GT21L16T1W, GT30L16U2W, GT30L24T3Y, GT30L24M1Z, and GT30L32S4W, GT20L24F6Y, GT21L24S1W.
- User-defined Characters support half size (8x16/12x24/16x32) & full size
- Programmable Text Cursor for Writing with Character
- Character Enlargement Function X1, X2, X3, X4 for Horizontal/Vertical Direction
- Support Character 90 degree Rotation

2.10.2 DMA function

- Support direct data transfer from external serial flash to frame buffer

2.10.3 General SPI master

- Compatible with Motorola's SPI specifications
- 16 bytes entries deep read FIFO
- 16 bytes entries deep write FIFO
- Interrupt generation after Tx FIFO empty and SPI Tx/Rx engine idle

2.11 IIC Interface

- IIC master interface
 - For the expand I/O device, external touch screen controller for panel control
 - Support Standard mode (100kbps) and Fast mode (400kbps)

2.12 PWM Timer

- Two 16-bit timers
- One 8-bit pre-scalars & One 4-bit divider
- Programmable duty control of output waveform (PWM)
- Auto reload mode or one-shot pulse mode
- Dead-zone generator

2.13 Key-scan Interface

- Support up-to 5x5 key matrix (share with the GPIO pin)
- Programmable scan period
- Support long Key & repeat key
- Support up to 2 keys are pressed simultaneously
Note: Restricted support 3-keys are pressed simultaneously (3-keys cannot form 90°)
- Support Key-Scan Wakeup function

2.14 Power Saving

- Support 3 kind of power saving mode
 - Standby mode, Suspend mode & Sleep mode
- It may wakeup by host, key & external event

2.15 Clock Source

- Embedded programmable PLL for system core clock, LCD panel scan clock and the SDRAM clock
- Single crystal clock input: (XI/XO: 10-15MHz)
- Internal system clock (Maximum 40MHz)
- SDRAM clock (Maximum 40MHz)
- LCD panel scan clock (Maximum 20MHz)

2.16 Reset

- Accept external hardware reset to synchronize with system
- Software command reset

2.17 Power Supply

- I/O voltage: 3.3V +/- 0.3V
- Embedded 1.2V LDO for core power

2.18 Package

- LQFP-128
- Operation temperature: -40°C ~ 85°C

3. Symbol and Package

3.1 RA8871L4N Symbol & Pin Assignment

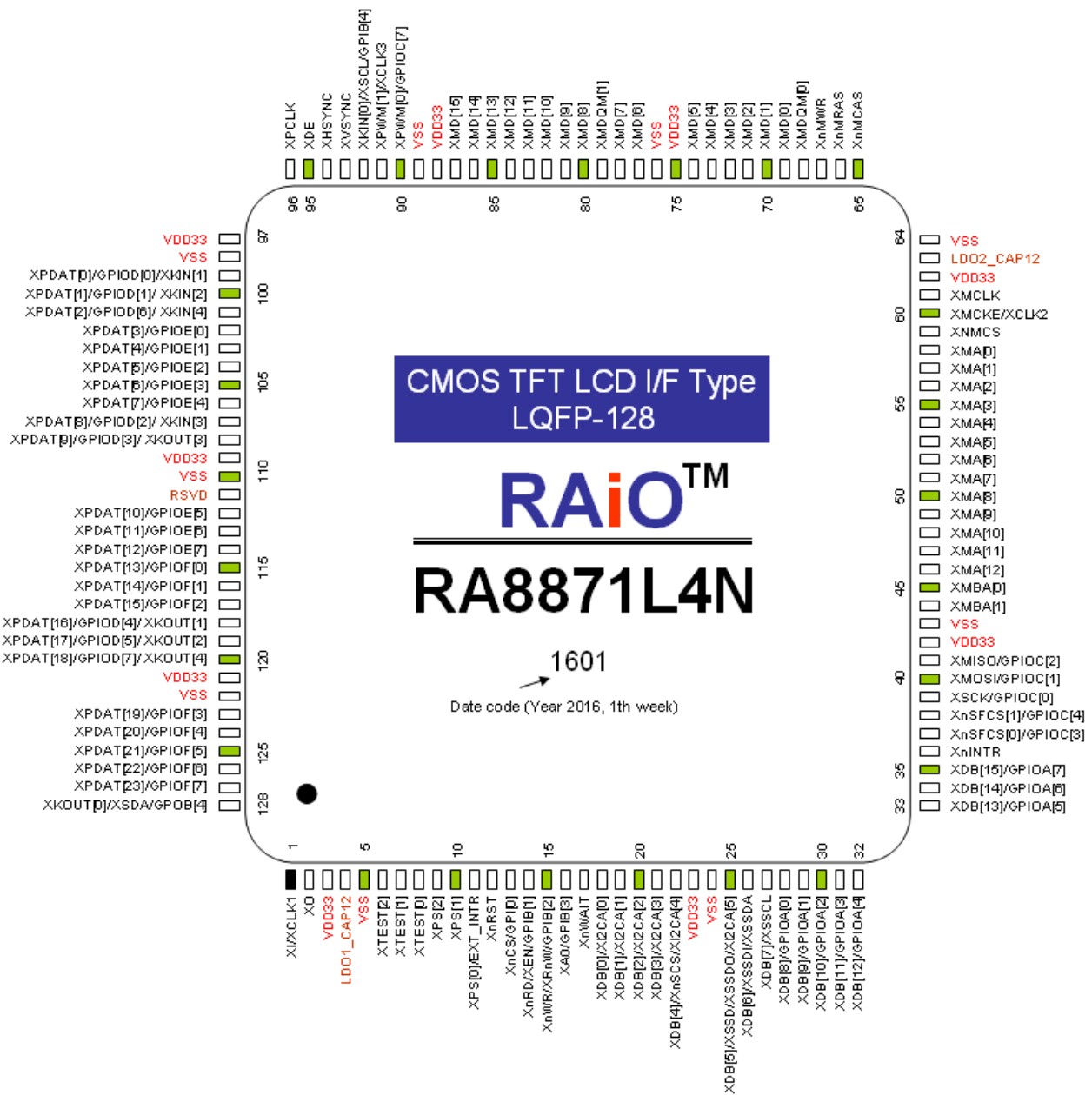
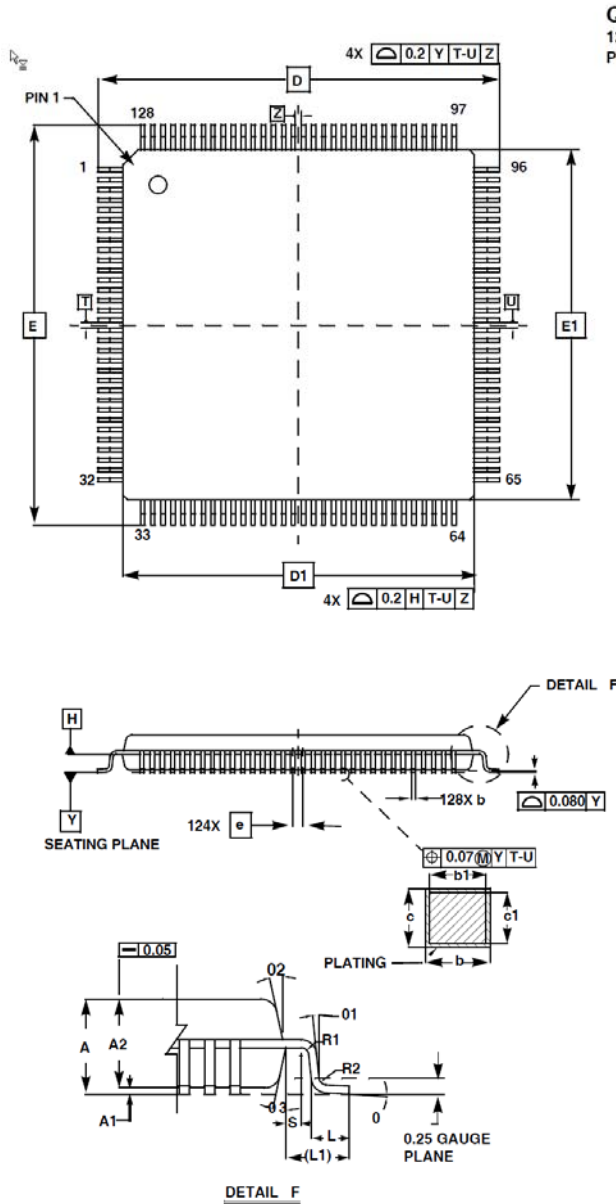

Figure 3-1

3.2 Package Outline Dimensions



Q128.14x14
128 LEAD THIN PLASTIC QUAD FLATPACK PACKAGE .4 MM PITCH

SYMBOL	MILLIMETERS			NOTES
	MIN	NOM	MAX	
A	-		1.60	-
A1	0.05		0.15	-
A2	1.35	1.40	1.45	-
b	0.13	0.16	0.23	4
b1	0.13	-	0.19	-
c	0.09	-	0.20	-
c1	0.09	-	0.16	-
D	16 BSC			-
D1	14 BSC			3
E	16 BSC			-
E1	14 BSC			3
L	0.45	0.60	0.75	-
L1	1.00 REF			-
R1	0.08	-	-	-
R2	0.08	-	0.20	-
S	0.20	-	-	-
0	0°	3.5°	7°	-
01	0°	-	-	-
02	11°	12°	13°	-
03	11°	12°	13°	-
N	128			-
e	0.40 BSC			-

Rev. 0 8/08

NOTES:

1. Dimensions are in millimeters. Dimensions in () for Reference Only.
2. Dimensions and tolerances per AMSEY14.5M-1994.
3. Dimensions D1 and E1 are excluding mold protrusion. Allowable protrusion is 0.25 per side. Dimensions D1 and E1 are exclusive of mold mismatch and determined by datum plane H.
4. Dimension b does not include dambar protrusion. Allowable dambar protrusion shall not cause the lead width to exceed the maximum b dimension by more than 0.08mm. Dambar cannot be located at the lower radius or the foot. Minimum space between protrusion and an adjacent lead is 0.07 mm.

Figure 3-2 : RA8871L4N Package Outline Dimensions

4. Signal Description

4.1 Parallel Host Interface (25 signals)

Pin Name	Dir/Drv.	Pin Description
XDB[15:0]	IO (8mA)	Data Bus These are data bus for data transfer between parallel host and RA8871. XDB[15:8] will become GPIO (GPIO-A[7:0]) if parallel host 8080/6800 16-bit data bus mode doesn't set. XDB[7:0] are multiplex with serial host signals if serial host mode set. Please refer to serial host interface section.
XA0	I	Command / Data Select Input The pin is used to select command/data cycle. XA0 = 0, status read / command write cycle is selected. XA0 = 1, data read / Write cycle is selected.
XnCS	I	Chip Select Input Low active chip select pin. If host I/F set as serial host mode then this pin can be read from GPI-B0. With internal pull-high with resistor.
XnRD (XEN)	I	Enable/Read Enable When MPU interface (I/F) is 8080 series, this pin is used as XnRD signal (Data Read) , active low. When MPU I/F is 6800 series, this pin is used as XEN signal (Enable), active high. If host I/F set as serial host mode then this pin can be read from GPI-B1. With internal pull-high with resistor.
XnWR (XRnW)	I	Write/Read-Write When MPU I/F is 8080 series, this pin is used as XnWR signal (data write) , active low. When MPU I/F is 6800 series, this pin is used as XRnW signal (data read/write control). Active high for read and active low for write. If host I/F set as serial host mode then this pin can be read from GPI-B2. With internal pull-high with resistor.
XnINTR	O (8mA)	Interrupt Signal Output The interrupt output for host to indicate the status.
XnWAIT	O (8mA)	Wait Signal Output When high, it indicates that the RA8871 is ready to transfer data. When low, then microprocessor is in wait state.
XPS[2:0]	I	Parallel /Serial Host I/F Select 00X: (parallel host) 8080 interface with 8/16-bit data bus 01X: (parallel host) 6800 interface with 8/16-bit data bus 100: (serial host) 3-Wire SPI 101: (serial host) 4-Wire SPI 11x: (serial host) IIC Note: If host I/F set as parallel host mode, then XPS[0] pin is external interrupt pin.

4.2 Serial Host Interface (Multiplex with Parallel Host Interface)

Pin Name	Dir/Drv.	Pin Description
XSSCL (XDB[7])	I	SPI or IIC Clock XSSCL, 3-wire, 4-wire Serial or IIC I/F clock.
XSSDI XSSDA (XDB[6])	I	IIC data /4-wire SPI Data Input 3-wire SPI I/F: NC, please connect it to GND. 4-wire SPI I/F: XSSDI, Data input for serial I/F. IIC I/F: XSSDA, Bi-direction data for serial I/F
XSSD XSSDO (XDB[5])	IO	3-wire SPI Data /4-wire SPI Data Output/IIC Slave Address Select 3-wire SPI I/F: XSSD, Bi-direction data for serial I/F 4-wire SPI I/F: XSSDO, Data output for serial I/F. IIC I/F: XIICA[5], IIC device address bit [5]
XnSCS (XDB[4])	I	SPI Chip Select/IIC Slave Address Select XnSCS, Chip select pin for 3-wire or 4-wire serial I/F. IIC I/F : XIICA[4], IIC device address bit [4].
XIICA[3:0] (XDB[3:0])	I	IIC I/F: IIC Slave Address Select. XIICA[3:0], 3 4-wire SPI I/F: NC, please connect it to GND. IIC I/F : IIC device address bit [3:0]

4.3 SDR SDRAM Interface (39 signals)

Pin Name	Dir/Drv.	Pin Description
XMCKE (XCLK2)	IO (8mA)	Clock enable / Clock 2 input (memory clock) When XTEST[0] set low, this pin is SDR memory clock enable When XTEST[0] set high, this pin is external clock 2 input for SDR access.
XMCLK	IO (8mA)	SDR memory Clock out It derives from MPLL or XCLK2
XnMCS	O (4mA)	Chip select
XnMRAS	O (4mA)	Command outputs: XnMRAS, XnMCAS and XnMWR (along with XnMCS) define the command being entered
XnMCAS	O (4mA)	Command outputs
XnMWR	O (4mA)	Command outputs
XMBA[1:0]	O (4mA)	Bank address
XMA[12:0]	O (4mA)	Address , XMA[12] NC pin.
XMD[15:0]	I/O (4mA)	Data bus.
XMDQM[1:0]	O (4mA)	Input/Output mask

4.4 Serial Flash or SPI master Interface (5 signals)

Pin Name	Dir/Drv.	Pin Description
XnSFCS0	IO (8mA)	Chip Select 0 for External Serial Flash/ROM or SPI device SPI Chip select pin #0 for serial Flash/ROM or SPI device. * If SPI master I/F is disabled then it can be programmed as GPIO (GPIO-C3); default is GPIO-C3 input function.
XnSFCS1	IO (8mA)	Chip Select 1 for External Serial Flash/ROM or SPI device SPI Chip select pin #1 for serial Flash/ROM or SPI device. * If SPI master I/F is disabled then it can be programmed as GPIO (GPIO-C4); default is GPIO-C4 input function. *auto pull-high in reset period if xtest[2:1] is not equal to 01b.
XSCK	IO (8mA)	SPI Serial Clock Serial clock output for serial Flash/ROM or SPI device. * If SPI master I/F is disabled then it can be programmed as GPIO (GPIO-C0); default is GPIO-C0 input function.
XMOSI (XSIO0)	IO (8mA)	Master Output Slave Input Single mode: Data input of serial Flash/ROM or SPI device. For RA8871, it is output. Dual mode: The signal is used as bi-direction data #0(SIO0). Only valid in serial flash DMA mode. * If SPI master I/F is disabled then it can be programmed as GPIO (GPIO-C1); default is GPIO-C1 input function.
XMISO (XSIO1)	IO (8mA)	Master Input Slave Output Single mode: Data output of serial Flash/ROM or SPI device. For RA8871, it is input. Dual mode: The signal is used as bi-direction data #1(SIO1). Only valid in serial flash DMA mode. * If SPI master I/F is disabled then it can be programmed as GPIO (GPIO-C2); default is GPIO-C2 input function.

4.5 PWM Interface (2 signals)

Pin Name	Dir/Drv.	Pin Description
XPWM0	IO (8mA)	PWM signal output 1 / Initial Display Enable Pull-high this pin will enable Initial Display function. This pin has internal pull-down in reset period to disable Initial Display function by default. i.e. after reset complete, internal pull-down resistor will be disabled. XPWM 0 output mode is decided by configuration register. If PWM function disabled then it can be programmed as GPIO (GPIO-C7), default is GPIO-C7 input function, or output core clock.
XPWM1 (XCLK3)	IO (8mA)	PWM signal output 2 / Clock 3 input (panel scan clock) When XTEST[0] set low: XPWM1 set as output mode & output function is decided by configuration register. It may normal XPWM1 function, oscillator clock output or error flag for Scan bandwidth insufficient or Memory access out of range. (or Iso clock output) When XTEST[0] set high: XPWM1 pin is external panel scan clock input

4.6 KEYSKAN Interface (10 signals)

Pin Name	Dir/Drv.	Pin Description
XKIN[4:0]	I	Keypad Data Line or GPIs (General Purpose Input) Keypad data inputs (Default), with internal pull-up resistor. XKIN[0] also has IIC master's XSCL function. In RA8871, XKIN [4:1] are share with XPDAT & GPIO-D.
XKOUT[4:0]	O (2mA)	Keypad Strobe Line or GPOs (General Purpose Output) Keypad matrix strobe lines outputs with open-drain. (Default). XKOUT[0] also has IIC master's XSDA function. In RA8871, XKOUT [4:1] are share with XPDAT & GPIO-D.

4.7 LCD Panel Digital Interface (28 signals)

Pin Name	Dir/Drv.	Pin Description																																																																																																																																	
XPCLK	O (8mA)	Panel scan Clock Generic TFT interface signal for panel scan clock. It derives from SPLL.																																																																																																																																	
XVSYNC	O (4mA)	VSYNC Pulse Generic TFT interface signal for vertical synchronous pulse.																																																																																																																																	
XHSYNC	O (4mA)	HSYNC Pulse Generic TFT interface signal for horizontal synchronous pulse.																																																																																																																																	
XDE	O (4mA)	Data Enable Generic TFT interface signal for data valid or data enable.																																																																																																																																	
XPDAT [23:0]	IO (4mA)	LCD Panel Data Bus TFT LCD data bus output for source driver. RA8871 supports 64K/256K/16.7M color depth by register setting; user can connect corresponding RGB bus for different setting.																																																																																																																																	
		<table border="1"> <thead> <tr> <th rowspan="2">Pin Name</th> <th colspan="4">Digital TFT Interface</th> </tr> <tr> <th>11b (GPIO)</th> <th>10b (16-bit)</th> <th>01b (18-bit)</th> <th>00b (24-bit)</th> </tr> </thead> <tbody> <tr> <td>XPDAT[0]</td> <td colspan="3">GPIO-D0/ XKIN[1]</td> <td>B0</td> </tr> <tr> <td>XPDAT[1]</td> <td colspan="3">GPIO-D1/ XKIN[2]</td> <td>B1</td> </tr> <tr> <td>XPDAT[2]</td> <td colspan="2">GPIO-D6/ XKIN[4]</td> <td>B0</td> <td>B2</td> </tr> <tr> <td>XPDAT[3]</td> <td>GPIO-E0</td> <td>B0</td> <td>B1</td> <td>B3</td> </tr> <tr> <td>XPDAT[4]</td> <td>GPIO-E1</td> <td>B1</td> <td>B2</td> <td>B4</td> </tr> <tr> <td>XPDAT[5]</td> <td>GPIO-E2</td> <td>B2</td> <td>B3</td> <td>B5</td> </tr> <tr> <td>XPDAT[6]</td> <td>GPIO-E3</td> <td>B3</td> <td>B4</td> <td>B6</td> </tr> <tr> <td>XPDAT[7]</td> <td>GPIO-E4</td> <td>B4</td> <td>B5</td> <td>B7</td> </tr> <tr> <td>XPDAT[8]</td> <td colspan="3">GPIO-D2/ XKIN[3]</td> <td>G0</td> </tr> <tr> <td>XPDAT[9]</td> <td colspan="3">GPIO-D3/ XKOUT[3]</td> <td>G1</td> </tr> <tr> <td>XPDAT[10]</td> <td>GPIO-E5</td> <td>G0</td> <td>G0</td> <td>G2</td> </tr> <tr> <td>XPDAT[11]</td> <td>GPIO-E6</td> <td>G1</td> <td>G1</td> <td>G3</td> </tr> <tr> <td>XPDAT[12]</td> <td>GPIO-E7</td> <td>G2</td> <td>G2</td> <td>G4</td> </tr> <tr> <td>XPDAT[13]</td> <td>GPIO-F0</td> <td>G3</td> <td>G3</td> <td>G5</td> </tr> <tr> <td>XPDAT[14]</td> <td>GPIO-F1</td> <td>G4</td> <td>G4</td> <td>G6</td> </tr> <tr> <td>XPDAT[15]</td> <td>GPIO-F2</td> <td>G5</td> <td>G5</td> <td>G7</td> </tr> <tr> <td>XPDAT[16]</td> <td colspan="3">GPIO-D4/ XKOUT[1]</td> <td>R0</td> </tr> <tr> <td>XPDAT[17]</td> <td colspan="3">GPIO-D5/ XKOUT[2]</td> <td>R1</td> </tr> <tr> <td>XPDAT[18]</td> <td colspan="2">GPIO-D7/ XKOUT[4]</td> <td>R0</td> <td>R2</td> </tr> <tr> <td>XPDAT[19]</td> <td>GPIO-F3</td> <td>R0</td> <td>R1</td> <td>R3</td> </tr> <tr> <td>XPDAT[20]</td> <td>GPIO-F4</td> <td>R1</td> <td>R2</td> <td>R4</td> </tr> <tr> <td>XPDAT[21]</td> <td>GPIO-F5</td> <td>R2</td> <td>R3</td> <td>R5</td> </tr> <tr> <td>XPDAT[22]</td> <td>GPIO-F6</td> <td>R3</td> <td>R4</td> <td>R6</td> </tr> <tr> <td>XPDAT[23]</td> <td>GPIO-F7</td> <td>R4</td> <td>R5</td> <td>R7</td> </tr> </tbody> </table>	Pin Name	Digital TFT Interface				11b (GPIO)	10b (16-bit)	01b (18-bit)	00b (24-bit)	XPDAT[0]	GPIO-D0/ XKIN[1]			B0	XPDAT[1]	GPIO-D1/ XKIN[2]			B1	XPDAT[2]	GPIO-D6/ XKIN[4]		B0	B2	XPDAT[3]	GPIO-E0	B0	B1	B3	XPDAT[4]	GPIO-E1	B1	B2	B4	XPDAT[5]	GPIO-E2	B2	B3	B5	XPDAT[6]	GPIO-E3	B3	B4	B6	XPDAT[7]	GPIO-E4	B4	B5	B7	XPDAT[8]	GPIO-D2/ XKIN[3]			G0	XPDAT[9]	GPIO-D3/ XKOUT[3]			G1	XPDAT[10]	GPIO-E5	G0	G0	G2	XPDAT[11]	GPIO-E6	G1	G1	G3	XPDAT[12]	GPIO-E7	G2	G2	G4	XPDAT[13]	GPIO-F0	G3	G3	G5	XPDAT[14]	GPIO-F1	G4	G4	G6	XPDAT[15]	GPIO-F2	G5	G5	G7	XPDAT[16]	GPIO-D4/ XKOUT[1]			R0	XPDAT[17]	GPIO-D5/ XKOUT[2]			R1	XPDAT[18]	GPIO-D7/ XKOUT[4]		R0	R2	XPDAT[19]	GPIO-F3	R0	R1	R3	XPDAT[20]	GPIO-F4	R1	R2	R4	XPDAT[21]	GPIO-F5	R2	R3	R5	XPDAT[22]	GPIO-F6	R3	R4	R6	XPDAT[23]	GPIO-F7	R4	R5	R7
		Pin Name		Digital TFT Interface																																																																																																																															
			11b (GPIO)	10b (16-bit)	01b (18-bit)	00b (24-bit)																																																																																																																													
		XPDAT[0]	GPIO-D0/ XKIN[1]			B0																																																																																																																													
		XPDAT[1]	GPIO-D1/ XKIN[2]			B1																																																																																																																													
		XPDAT[2]	GPIO-D6/ XKIN[4]		B0	B2																																																																																																																													
		XPDAT[3]	GPIO-E0	B0	B1	B3																																																																																																																													
		XPDAT[4]	GPIO-E1	B1	B2	B4																																																																																																																													
		XPDAT[5]	GPIO-E2	B2	B3	B5																																																																																																																													
		XPDAT[6]	GPIO-E3	B3	B4	B6																																																																																																																													
		XPDAT[7]	GPIO-E4	B4	B5	B7																																																																																																																													
		XPDAT[8]	GPIO-D2/ XKIN[3]			G0																																																																																																																													
		XPDAT[9]	GPIO-D3/ XKOUT[3]			G1																																																																																																																													
		XPDAT[10]	GPIO-E5	G0	G0	G2																																																																																																																													
		XPDAT[11]	GPIO-E6	G1	G1	G3																																																																																																																													
		XPDAT[12]	GPIO-E7	G2	G2	G4																																																																																																																													
		XPDAT[13]	GPIO-F0	G3	G3	G5																																																																																																																													
		XPDAT[14]	GPIO-F1	G4	G4	G6																																																																																																																													
		XPDAT[15]	GPIO-F2	G5	G5	G7																																																																																																																													
		XPDAT[16]	GPIO-D4/ XKOUT[1]			R0																																																																																																																													
		XPDAT[17]	GPIO-D5/ XKOUT[2]			R1																																																																																																																													
		XPDAT[18]	GPIO-D7/ XKOUT[4]		R0	R2																																																																																																																													
		XPDAT[19]	GPIO-F3	R0	R1	R3																																																																																																																													
		XPDAT[20]	GPIO-F4	R1	R2	R4																																																																																																																													
		XPDAT[21]	GPIO-F5	R2	R3	R5																																																																																																																													
		XPDAT[22]	GPIO-F6	R3	R4	R6																																																																																																																													
		XPDAT[23]	GPIO-F7	R4	R5	R7																																																																																																																													
*unused pins can be programmed as GPIO-D/E/F (default) or XKIN/XOUT. Default is 18bpp function mode, so XPDAT[17:16/8:9/1:0] are default at GPI mode.																																																																																																																																			

4.8 Clock, Reset & Test Mode (6 signals)

Pin Name	Dir/Drv.	Pin Description
XI (XCLK1)	I	Crystal Input Pin / Clock 1 input (core clock) Crystal Oscillator range is 10MHz ~ 15MHz. When XTEST[0] set low, this input pin for internal crystal circuit. It should be connected to external crystal circuit. That will generate the clock for RA8871. When XTEST[0] set high, this pin is external clock 1 input. Suggested OSC frequency is 11.0592MHz.
XO	O	Crystal Output Pin This is an output pin for internal crystal circuit. It should be connected to external crystal circuit.
XnRST	I/OC	Reset Signal input To avoid noise interfere XnRST signal and cause fake reset behavior, external XnRST level will be admitted only if it keep its signal level at least 256 OSC clocks.
XTEST[0]	I	Clock Test Mode Internal pull down. For chip test function, should be connected to GND for normal operation. 0: Normal mode, Use internal PLL clock. 1: bypass internal PLL clock and instead them with CLK1I, CLK2I & CLK3I.
XTEST[2:1]	I	Chip Test Mode 00: normal mode 01: Force SPI master I/F pin floating (for in-system-programming) 1X: RESERVED

4.9 Power and Ground

Pin Name	Dir/Drv.	Pin Description
LDO1_CAP12 LDO2_CAP12	P	Loading Capacitor for each LDO Connect a 1uF capacitor to ground.
VDD33	P	IO VDD 3.3V IO power input.
VSS	P	GND IO Cell/Core ground signal
RSVD	P	Reserved Suggest to connect a 1uF capacitor to ground.