

# THICK FILM RESISTOR NETWORKS

## THICK FILM RESISTOR NETWORK (SIP TYPE)

Thick film resistor networks have metal glaze elements on the ceramic substrates with strong clip-construction terminals, and are coated with special epoxy resin. They are originally designed, as a style of single in line package, and are the most suitable to meet the density of circuit assembling.

### Features:

1. Small in size with high precision package. It is suitably used in printed circuit board.
2. Automated machinery mass production and competitive prices accordingly.
3. Extremely high stability, accuracy and reliability.

## General Specification

Operating Temp. Range	- 55°C ~ + 125°C		Wattage/Element	RA		RB
T.C.R.	± 100 PPM	50 ohm ~ 2.2M ohm		B Circuits	Others	All Circuits
	± 250 PPM	<50 ohm or 2.2M ohm	0.2W	0.125W	0.25W	
Rating Ambient Temp.	+ 70°C		Max. Working Voltage	100V		200V
Resistance Range (E-12 Series)	R Circuit	Others	Resistance Tolerance	F = ± 1%, G = ± 2%, J = ± 5%		
	100 Ω -10K	10 Ω -4.7M Ω				

## Internal Circuit

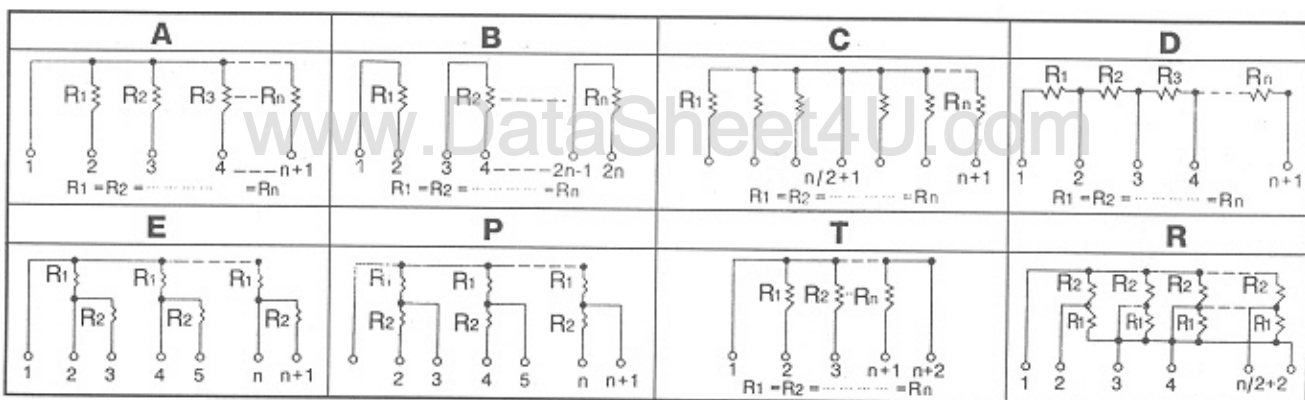

## DIMENSIONS (STANDARD TYPE)

## DUAL TERMINATORS (R1/R2) (OHM)

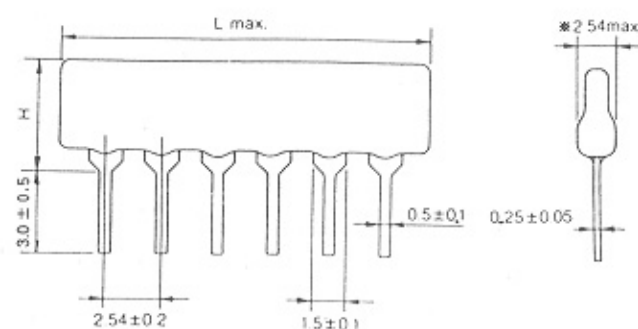

160/240

330/390

180/390

330/470

220/270

1.5K/3.3K

220/330

3.0K/6.2K

L

H MAX

NO: PS											RA	RB
4	5	6	7	8	9	10	11	12	13	14	5.08	7.5
10.2 MM	12.7	15.3	17.8	20.4	22.1	25.4	28.0	30.5	33.1	35.6		

## DERATING CURVE

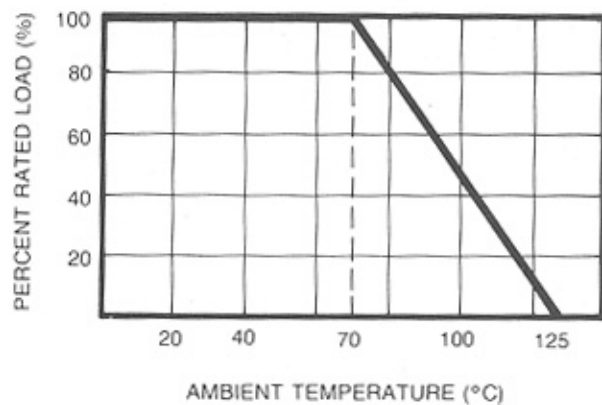

## SHORT TIME OVERLOAD

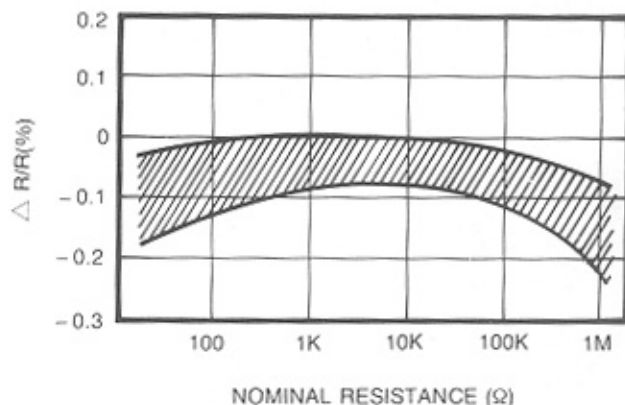

## Characteristic Performance

Test Items	Specification
Insulation Resistance (200Vdc Applied)	$10^4$ M $\Omega$ or Greater
Thermal Shock ( - 55°C to + 125°C, 5 Cycles)	$\Delta$ R/R: $\pm$ (0.5% + 0.1 $\Omega$ )
Short Time Overload (2.5 $\times$ Rated Voltage, 5 Sec.)	$\Delta$ R/R: $\pm$ (0.5% + 0.1 $\Omega$ )
Resistance to Soldering Heat ( + 260°C $\pm$ 5°C, 10 Sec.)	$\Delta$ R/R: $\pm$ (0.5% + 0.1 $\Omega$ )
Heat Shock ( + 25°C to + 125°C, 5 Cycles)	$\Delta$ R/R: $\pm$ (0.5% + 0.1 $\Omega$ )
Moisture Resistance, Constant State (40 °C, 95% R.H., 1,000Hrs.)	$\Delta$ R/R: $\pm$ (1% + 0.1 $\Omega$ )
High Temperature Exposure (125 °C, 100Hrs.)	$\Delta$ R/R: $\pm$ (1% + 0.1 $\Omega$ )
Moisture Load Life (1,000Hrs., 40 °C, 95% R.H.; - Rated Voltage Cycling)	$\Delta$ R/R: $\pm$ (3% + 0.1 $\Omega$ )
Load Life (1,000Hrs., Rated Voltage Cycling at 70 °C)	$\Delta$ R/R: $\pm$ (3% + 0.1 $\Omega$ )
Load Pull Strength (1kg, 10 Sec.)	$\Delta$ R/R: $\pm$ (0.5% + 0.1 $\Omega$ )
Temperature Coefficient ( - 55°C to 125°C)	$\pm$ 100ppm/°C $\pm$ 250ppm/°C for <50 $\Omega$ or >2.2M $\Omega$
Solderability (230 °C for 5 Sec.)	95% min. coverage
Note: Test methods and conditions are in accordance with MIL-R-83401	

## Marking

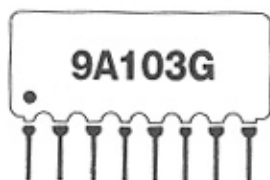

- 1 st Letter : Number of Pins
- 2 nd Letter : Type of Circuit
- 3 rd, 4th &
- 5 th Letters : Resistance Value
- 6 th Letter : Tolerance
- Dot : The First Pin

## Part Number System

