

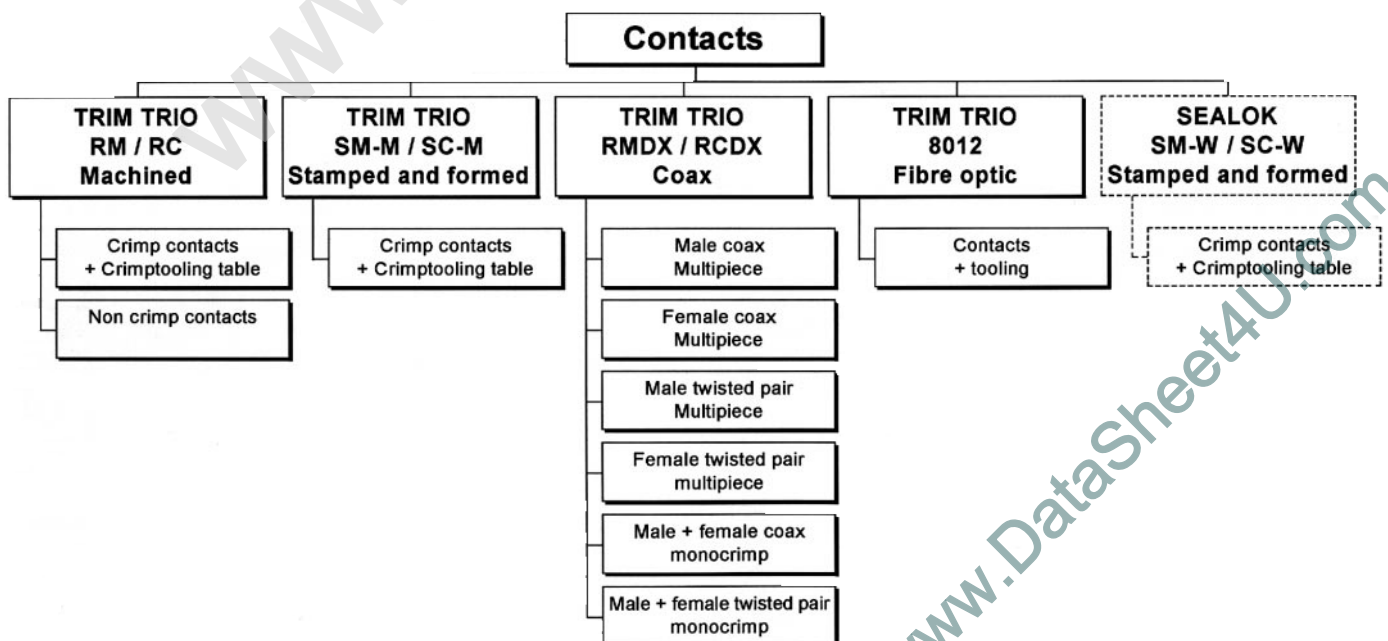

Overview TRIM TRIO and SEALOK contacts



Selection matrix TRIM TRIO and SEALOK contacts





Current ratings for multi-contact connectors

Choice of right connector - contact combination.

The choice of a Trim Trio connector in combination with a Trim Trio contact is essential and different for any application. There is considerable misunderstanding in the field on current carrying capabilities for the various contacts in the TrimTrio programme.

The intention of this part is to give guidance how to interpret the given current ratings in general and how to calculate them for particular applications.

The information given is based upon existing MIL specifications such as: MIL-C-26482, MIL-C-8384, MIL-T-7928, MIL-W-5086, MIL-W-5088, MIL-W-16878, etc. and in conjunction with long field practice.

Current carrying capabilities

Trim Trio contacts are designed to carry a specific current, in accordance with the applicable specification.

This specification will be defined by following variables:

- **Connector size**

The more contacts in a connector, the less current per contact can be loaded.

- **Wire size** (see table 1)

The cross section will determine the internal resistance and temperature rise for a given current.

- Table 1 gives the current ratings for the various wire sizes commonly used with Trim Trio contacts.

- **Current rating** (see table 2)

The current load for a given application will generate heat.

- Table 2 gives the *maximum current carrying capacity* of most of the Trim Trio contacts, the *maximum operating current* and the *recommended continuous current*.

- **Ambient temperature**

The combination of the connector size, the wire size and the current rating will generate a temperature rise.

This temperature rise + a given ambient temperature may not exceed the maximum operating temperature of the connector material (see performance characteristics for each connector family).

Table 1 - Current carrying capabilities per wire size

AWG	wire size mm ²	wire dia. mm Amp.	max.curr. carrying Amp.	max.operating curr. Amp.	recomm. cont. curr.
26	0.13	0.40	3	2	1
24	0.20	0.51	4.5	3	2
22	0.32	0.64	9	5	3
20	0.52	0.81	11	7.5	5
18	0.82	1.02	16	10	7.5
16	1.30	1.29	22	13	10
14	2.10	1.63	32	17	13

Table 2 - Current carrying capabilities per contact type

size	pin dia.	type	max. curr. carying Amp.	max. oper-ating curr. Amp.	recomm. cont. curr. Amp.
16	.062* 1.6 mm	RM / RC machined	22	13	10
		SM / SC 2 piece stamped	22	13	10
20	.040* 1.0 mm	SM-W / SC-W 2 piece stamped	11	7.5	5

- *Max. current carrying capacity*
- *Max. operating current*
- *Recommended continuous current*

What do these values mean in practice ?

• *Max current carrying capacity* of a contact is defined by the conducting section of the contact in its smallest area. The listed values are obtained from several tests in laboratories under room conditions (21°C). The contact is considered to be in free air.

• *Max operating current* is the current with which the contacts can be energized during a longer or shorter period, without deteriorating and depending on working conditions. These are dissipated heat, cooling provisions, ambient temperature, insulation material, etc.

• *Recommended continuous current* can be applied for all normal cases and working conditions. The values include a safety margin. However, there are restrictions in the application of the given values. The most important restriction is the used wire, its sectional area, insulation temperature range, as well as wires in bundles. Military specifications require that for a cable bundle of 15 conductors or more, the bundle shall not carry more than 20% of the total carrying capacity of the bundle. In smaller bundles, the allowable percentage of total current may be increased as the bundle approaches the single wire condition. This percentage of increase in total current carrying capacity of the bundle is 6% for each conductor less than 15 in a bundle.



From simple calculations, one can see that the closer the bundle approaches the single wire condition, the higher the allowable current per conductor becomes, to even such an extent, that it exceeds the recommended continuous current value. In that case, the recommended continuous value should have preference. In order to make this clear, we will give hereafter some typical examples.

• **Example 1**

Cable bundle, 48 conductors AWG20 (0.5mm²) used with circular TrimTrio connector with insert arrangement 24-48 and machined size 16 contacts RM/RC20.

- Total operating current capacity of bundle 48 x 7.5 A (table I) = 360 A
- Total allowable capacity for bundles of more than 15 wires is 20% = 72 A
- When all conductors are energized equally, this gives:
72 : 48 = 1.5 A per conductor

When for instance 5 conductors are energized to the recommended continuous current of 5 A (see table 1) resulting in 25 A consumption, the other conductors may not take more than
72 - 25 = 47 A all together, or 1 A per conductor.

Any other combination can of course also be taken as long as the total capacity of 72 A is not exceeded and the recommended continuous current is respected.

Remark

Please note that contacts used are of the size 16 type with maximum operating current of 13 A (table 2).

The maximum operating current of the bundle is however restricted to 7.5 A per conductor due to the wire size of AWG20 (see table 1).

• **Example 2**

Cable bundle, 14 conductors AWG22 (0.32 mm²) used with rectangular Trim Trio connector with insert arrangement for 14 contacts, and machined size 16 contacts RM / RC20.

- Total operating current capacity of bundle 14 x 5 (table I) = 70 A
- Total allowable for wire bundle of 15 wires less 1 is 20% + 6% = 26% gives 18.2 A.
- All conductors energized equally, gives:
18.2 : 14 = 1.3 A per conductor

This value is within the recommended rating of 3 A so that it can be applied. See also remark under example 1.

• **Example 3**

Cable bundle, 4 conductors AWG16 (1.3mm²) used with circular Trim Trio connector with insert arrangement 10-4 and stamped 2 piece contacts SM /SC.

- Total operating current capacity of bundle 4 x 13 A (table I) = 52 A
- Total allowable for wire bundle of 15 wires less 11 is 20% + 66% = 86% gives 44.7 A.
- All conductors energized equally, gives:
44.7 : 4 = 11.2 A per conductor

Since the recommended continuous current is 10 A, the conductor should not carry more than 10 A individually.

As said before, the recommended ratings are valid for most common wiring systems and under normal working conditions. For extreme conditions, the given values should be lowered. The percentage of current reduction should be investigated from case to case. A rule-of thumb which can be used for such cases is:

$$\underline{4 \text{ Amp. per mm}^2 \text{ wire section}}$$

It gives us for common used wire sizes the values listed in table 3.

Table 3 - Recommended continuous current for extreme working conditions

AWG	wire size mm ²	recommended continuous current Amp.
26	0.13	0.5
24	0.20	0.8
22	0.32	1.3
20	0.52	2.0
18	0.82	3.3
16	1.30	5.2
14	2.10	8.4



Crimping instructions

The conductor and insulation crimp section

Are designed to accommodate wire-conductor and insulation diameters, expressed in AWG (American Wire Gauge) or mm².

For each wire gauge, a correct crimp requires a crimp height that offers the highest performance.

This performance is defined as the highest tensile strength force.

A good conductor crimp can be guaranteed if the tensile strength force is equal or higher as indicated on the graph below. E.g. a conductor of AWG20 (0.52 mm²) has a good crimp if the tensile strength is min 84N.

The tensile strength force is measured in Newtons and is the wire-to-contact connection that will withstand when a straight axial load is applied to the terminated wire. This is however a destructive test and is therefore inappropriate as a 100% inspection method.

An alternative method is to measure crimp height. The crimp height is measured at the conductor-crimp section.

• **If the dimension is to small**, then the conductor is over-crimped and the wire strands could be damaged, which results in a lower tensile strength force.

• **If the dimension is to large**, then the conductor is under-crimped and the wire strands will not be deformed enough to assure that the crimp will pass the tensile strength test.

In both cases, the application tooling's crimp height should be adjusted. In order to have the right tooling's crimp height go and no-go gauges can be obtained and are defined in function of the type of crimp tooling and the wire gauge. For further information consult factory.

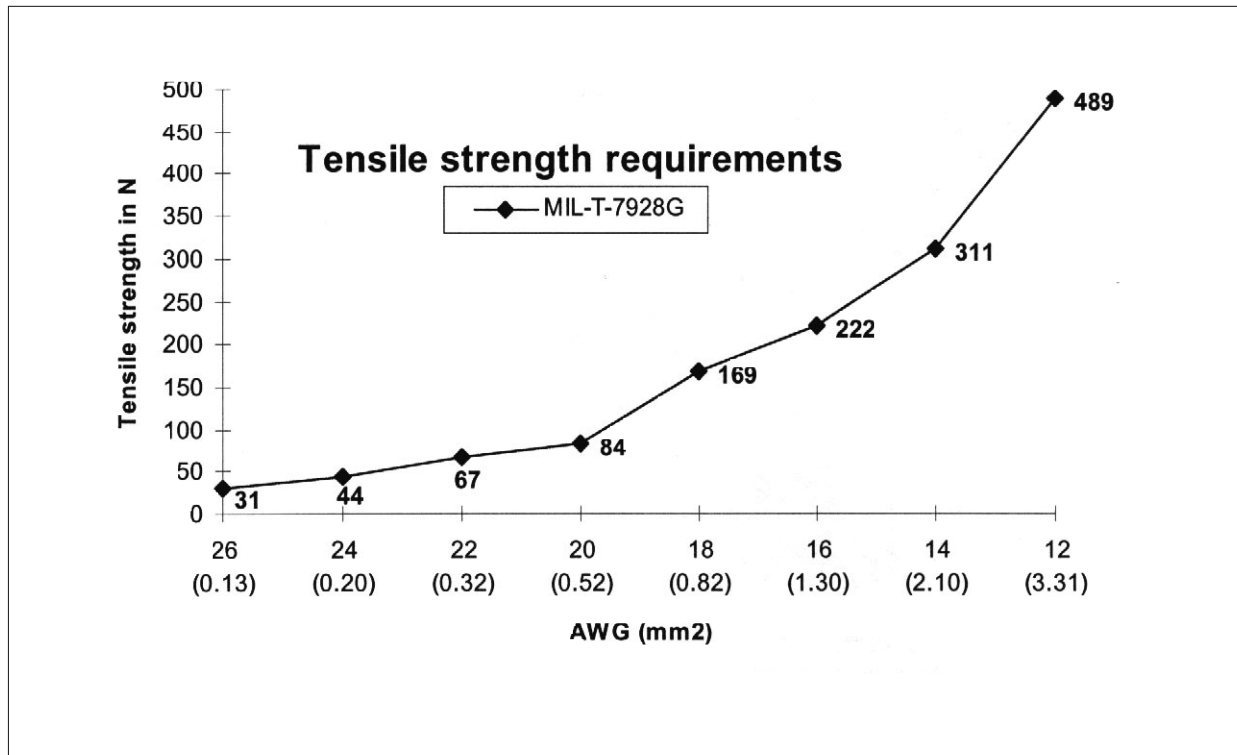



Size 16 solid machined contacts for TRIM TRIO connectors

Description

Size 16 RM/RC .0625" (1.6mm) diameter contacts are precision solid machined crimp snap-in pin and sockets for heavy duty top performance requirements.

Springs on both contacts are made of spring-tempered, heat-treated, beryllium copper.

The socket inner spring supplies high contact pressure to ensure low-resistance contact between pin and socket. The socket contact features closed entry to prevent probe damage. Crimp barrels have insulation grips for vibration support and are provided with a cable stop and inspection hole.

Features and benefits

- Made from high conductive copper alloy with gold or tin over nickel plate finish.
- Heat-treated beryllium copper locking springs assure proper locking and alignment of contacts in the housing.
- Colour coded for different wire sizes.
- Closed entry design on socket contact to prevent probe damage.
- Contacts available in bulk packing

Performance characteristics

Current rating:	13 Amp
Contact resistance:	≤ 3 mΩ
Operating voltage:	750 V RMS
Contact retention in body:	110 N min.
Individual insertion force:	3.5 N max.
Individual withdrawal force:	0.55 N min.

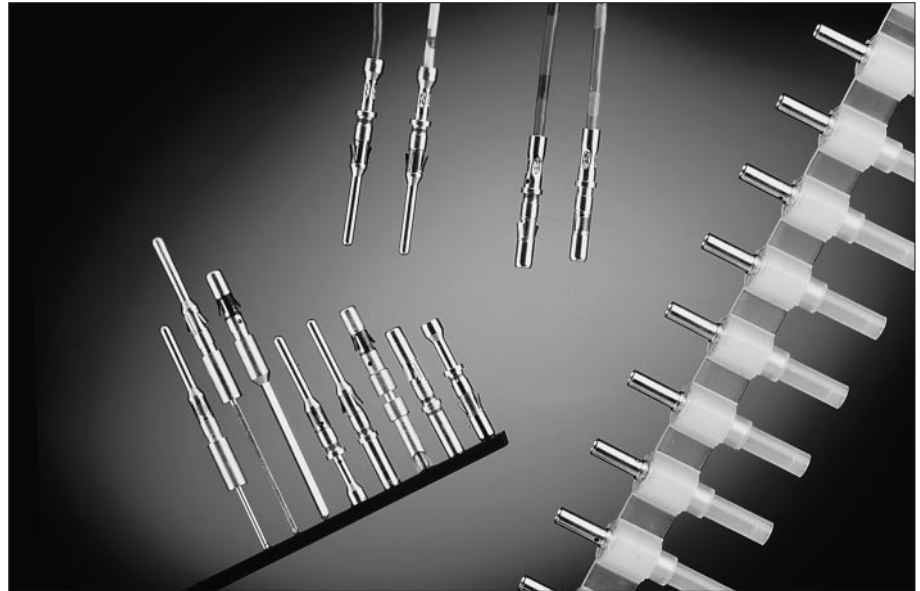

Construction

Contact body: High conductive copper alloy.

Outer spring: Tempered, heat-treated, non-plated beryllium copper.

Inner spring socket: Tempered, heat-treated, plated beryllium copper.

Plating table

K (std) = Min. 0.4 μ Gold all over, over Nickel

J = Gold flash all over, over Nickel

N = Min. 0.75 μ Gold all over, over Nickel

T = 3 - 5 μ Tin all over, over Nickel

Other platings on request

Connector accommodation

Any TRIM TRIO contact can be used in any contact position in any connector in the TRIM TRIO interconnection system.

- MS-M Rectangular connectors
- SMS Qikmate
- PI43 Eurorack connectors
- UT-Bantam
- UTG Metalok bantam
- UTP Full plastic bantam
- UTGS Shielded bantam
- MBG Bantamate II

How to order

	(K) RM	16	M	23	(GE1)	K	-
	(K) RC	16	M	23	(GE1)	K	-
Contact type:	RM: Male contact bulk packing						
	RC: Female contact bulk packing						
	KRM: Male contact on plastic carrier strip						
	KRC: Female contact on plastic carrier strip						
AWG Size:	16, 20, 24, 28						
Size 16:	.0625" (1.6mm) Diameter contacts						
Design variation:	Crimp barrel						
Grounding contact:							
Plating indication:	See plating table						
Packing quantity:	No digit (std) : 50 pcs. bulk packing (RM/RC)						
	: 2000 pcs on reel (KRM/KRC)						
	1000 : 1000 pcs bulk packing (RM/RC)						



Standard RM/RC crimp contacts: Contact size 16 - Pin diameter 1.57mm (.062")

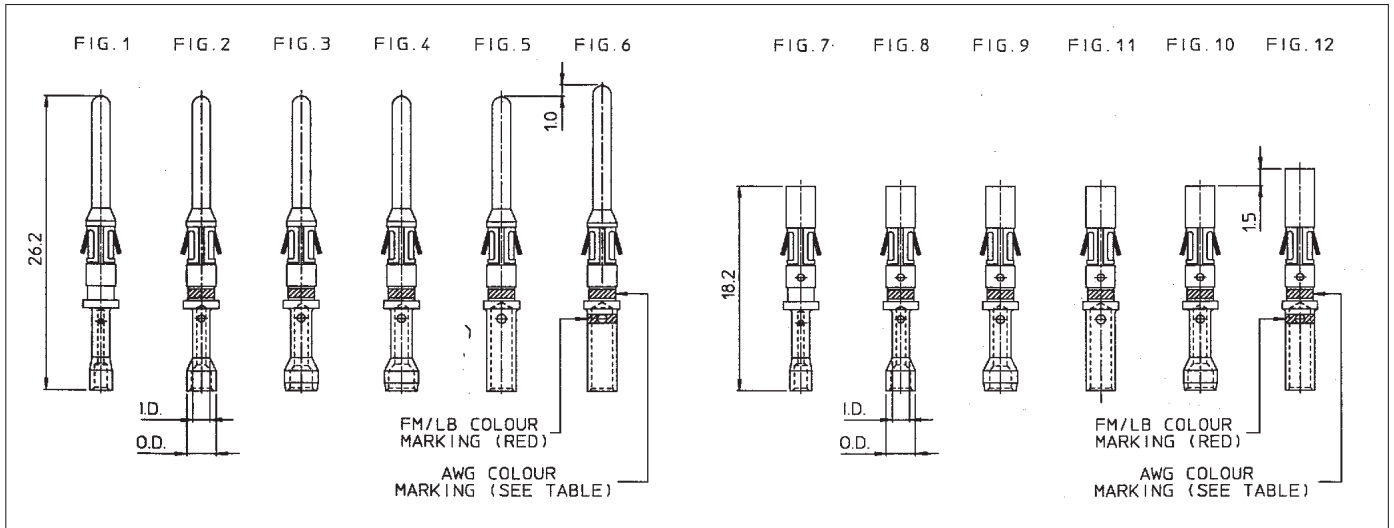

Dimensional table

Pin contacts	Part number		Fig.	Colour code	wire size		Max. wire dia.	Max. insul. dia.	wire strip length	I.D.	O.D.
	Fig.	Socket contacts			AWG	mm ²					
RM28M1K	1	RC28M1K	7	-	30 - 28	0.05 - 0.08	0.55	1.1	4.8	1.50	1.90
RM24M9K	2	RC24M9K	8	Red	26 - 24	0.13 - 0.20	0.8	1.7		1.50	2.55
RM20M13K	3	RC20M13K	9	Black	22 - 20	0.32 - 0.52	1.18	1.9		1.83	2.92
RM20M12K	4	RC20M12K	10	Blue	22 - 20	0.32 - 0.52	1.18	2.2		1.83	2.92
RM16M23K	5	RC16M23K	11	Green	20 - 16	0.52 - 1.50	1.82	3.2	7.1	2.55	-
RM16M23GE1K	6	RC16M23GE1K	12	Green + red	20 - 16	0.52 - 1.50	1.82	3.2		2.55	-

Packing quantity: 50 pcs bulk packing (standard)

For 1000 pcs bulk packing add "1000" at the end of the part number e.g. RM16M23K1000

For machined contact reeled on plastic carrier: put "K" in front of part number e.g. KRM16M23K

For other platings: See plating table

Crimptooling table

Size	Hand crimp tooling for loose contacts						Automatic crimp tooling for contacts on strip	Extraction tools
	Hand tools die set included	MH860		M10S1		M8ND	P100MAN (Press) Left side applicator KRM/KRC (not incl.)	
		Positioner (not incl.)	Locator setting	Die set (not incl.)	Stop bushing (not incl.)	Die set (not incl.)		
28	MR8GE5 and Y16RCM	MH86164G	4/6	S9	SL40	N24RT10	MLS228	RX2025GE1 or RX2025GE2
24			5/6	S10		N20RT30	MLS224	
20			5/7		N16RT21		MLS220	
16		MH86186	6/8	S3D1	SL115	N16RT25	MLS216	
16 GE1								

For detailed information on crimp tooling : See crimp tooling section



Special RM / RC contacts: Contact size 16 - Pin diameter 1.57mm (.062")

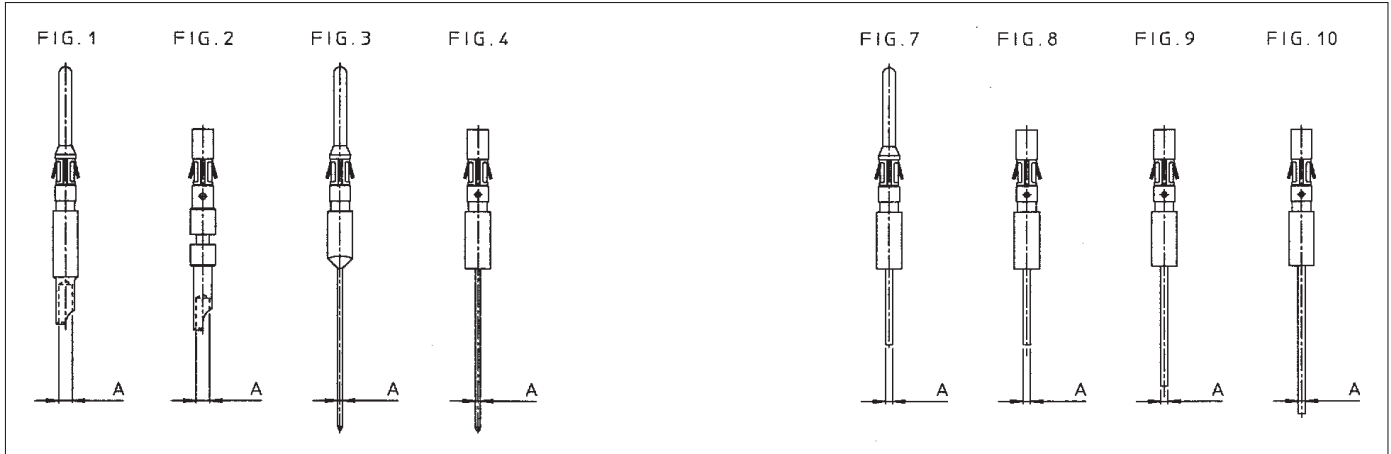

Pin contacts	Part number		Fig.	code	wire size		Post cross section A cavity	Length out of TRIM TRIO part number	Anti-rotating bushing
	Fig.	Socket contacts			AWG	mm ²			
RM16SEOK	1	RC16SE4K	2	Handsold	16 - 20	1.50 - 0.52	ø1.7	3.5	-
RM20M12G4K	3	RC20M12G4K	4	Mini - wrap	28 - 30	0.08 - 0.05	ø 0.636	16.0	J1661
RM20M12E8K	7	RC20M12E8K	8	Dipsolder	-	-	ø 0.9	5.2	-
		RC20M12E83K	9	Dipsolder	-	-	ø 0.9	10.4	-
		RC20M12384K	10	Dipsolder	-	-	ø 0.9	13.9	-

The RM/RC contact principle

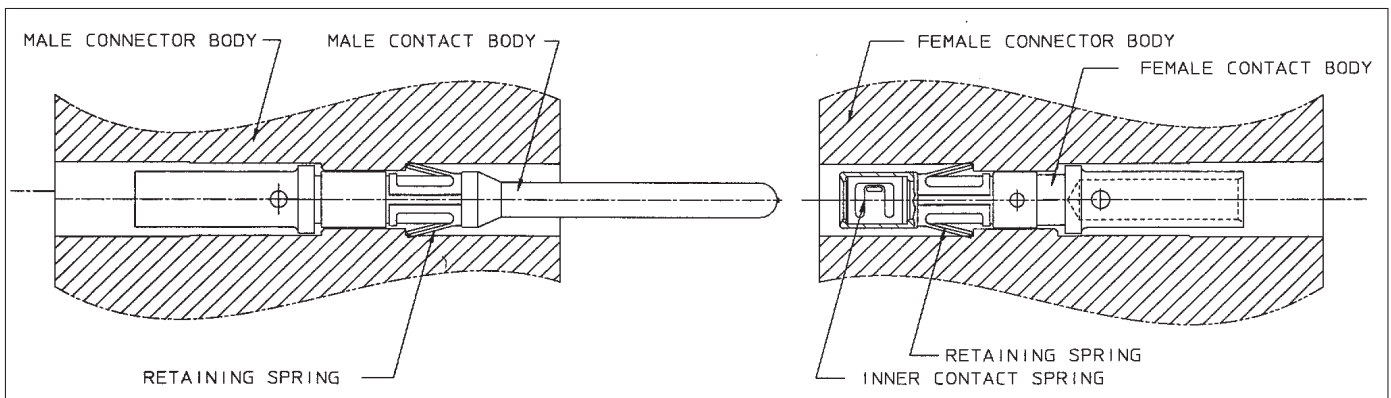

The RM/RC contact packing



50 pcs bulk packing (standard)



1000 pcs bulk packing

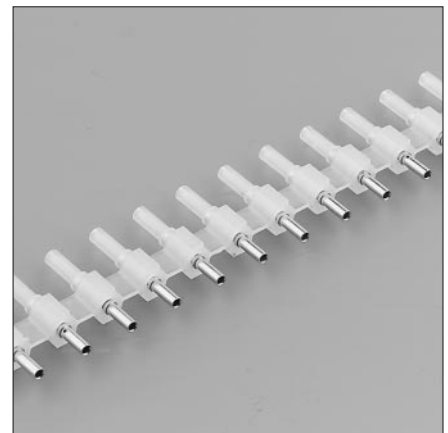

Reeled contacts on plastic carrier (qty 2000 pcs)



Size 16 stamped and formed contacts for TRIM TRIO connectors

Description

Size 16 SM/SC .0625" (1.6mm) diameter contacts are two piece strip formed crimp snap-in pin and sockets.

These contacts consist of a crimp body made of high conductive copper alloy, and a stainless steel retaining spring featuring retention in the housing cavity and a closed entry socket to prevent probe damage. The contact with its open barrel is standard available on strip and packaged with 3000 pcs on reel. This reel packaging combined with semi or even full automatic crimp tooling provides the added advantage of a lower installed cost.

Features and benefits

- Made from high conductive copper alloy with gold or tin over nickel plate finish.
- Two piece construction with dual purpose spring which serves for contact retention and protects the body against damage.
- Contacts available on reel (standard) and in bulk packing (100 pcs).
- Suitable for high volumes and lower installation cost.

Performance characteristics

Current rating:	13 Amp
Contact resistance:	≤ 6 mΩ
Operating voltage:	750 V RMS
Contact retention in body:	65 N min.
Individual insertion force:	3.5 N max.
Individual withdrawal force:	0.55 N min.

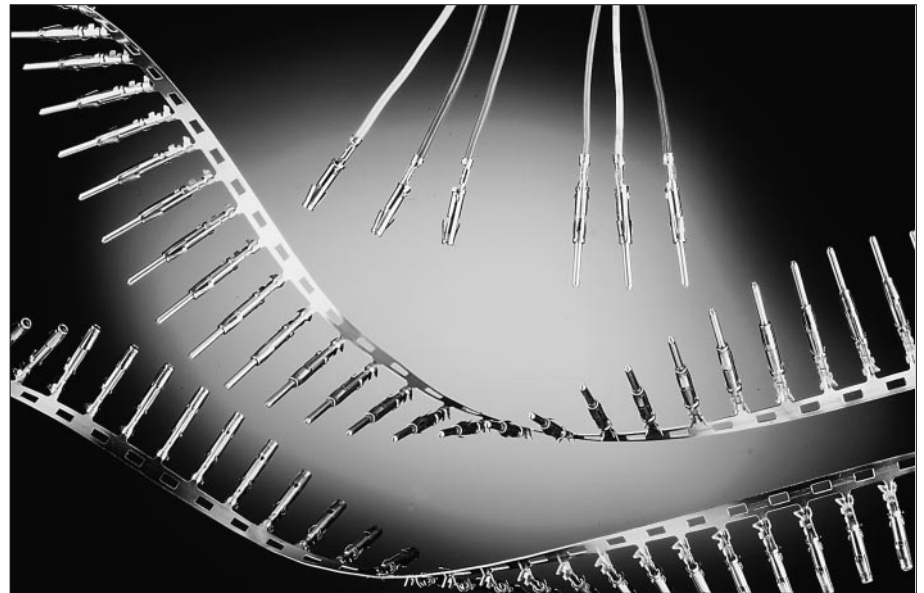

Construction

Contact body: High conductive copper alloy.
Outer spring: Stainless steel

Plating table

S6 = 0.75 μ Gold min. in contact area, flash on crimp barrel over Nickel.
D70 = Gold flash all over, over Nickel.
TK6 = Preplated Tin all over.

Connector accommodation

Any TRIM TRIO contact can be used in any contact position in any connector in the TRIM TRIO interconnection system.

- MS-M Rectangular connectors
- SMS Qikmate
- PI43 Eurorack connectors
- UT-Bantam
- UTG Metalok bantam
- UTP Full plastic bantam
- UTGS Shielded bantam
- MBG Bantamate II

How to order

	SM	16	M	(L)	1	S6
	SC	16	M	(L)	1	S6
Contact type:	SM: Male contact SC: Female contact					
AWG Size:	14, 16, 20, 24					
Type of crimp barrel:	American open crimp barrel					
Packing:	No digit: Contacts on strip (qty 3000 per reel) L: Preformed loose piece contacts					
Design variation	1 : Only wire crimp for size 14 and 16 : Wire + insulation crimp for sizes 20 and 24 11 : Wire + insulation crimp for size 16					
Plating indication:	See plating table					



Standard SM/SC crimp contacts: Contact size 16 - Pin diameter 1.57mm (.062")

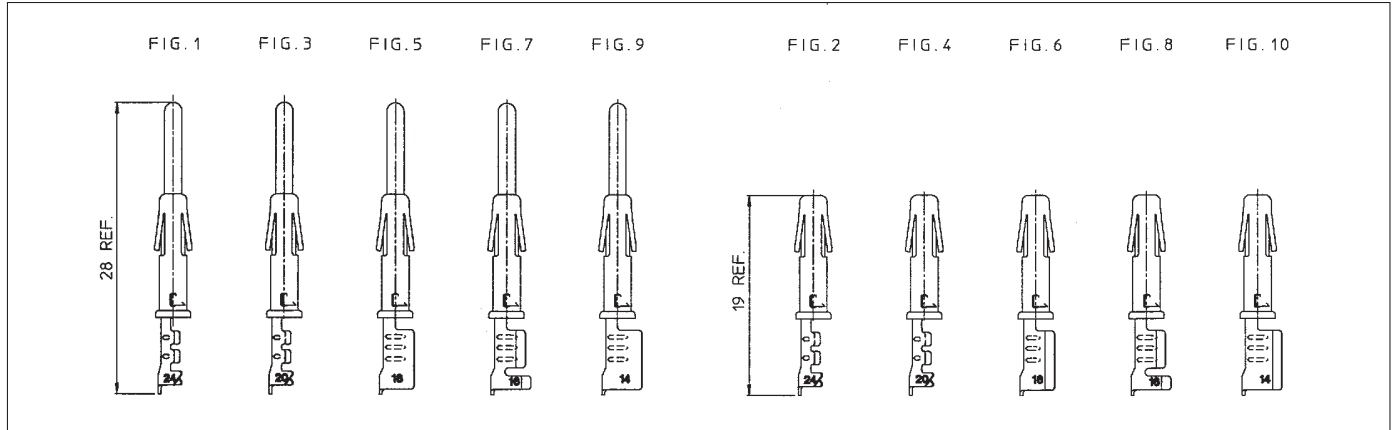

Dimensional table

Part number: contacts on strip Loose pieces				Wire size		Insulation diameter	Wire strip length
Pin contacts	Fig.	Socket contacts	Fig.	AWG	mm ²		
SM24M1S6 SM24ML1S6	1	SC24M1S6 SC24ML1S6	2	26 - 24	0.13 - 0.25	0.89 - 1.58	4.0
SM20M1S6 SM20ML1S6	3	SC20M1S6 SC20ML1S6	4	22 - 20	0.35 - 0.50	1.17 - 2.08	4.0
SM16M1S6 SM16ML1S6	5	SC16M1S6 SC16ML1S6	6	18 - 16	0.80 - 1.50	2.0 - 3.0	4.65
SM16M11S6 SM16ML11S6	7	SC16M11S6 SC16ML11S6	8	18 - 16	0.80 - 1.50	3.0	6.35
SM14M1S6 SM14ML1S6	9	SC14M1S6 SC14ML1S6	10	14	2.0	3.0	6.35

For other platings: See plating table.

Crimptooling table

Size	Hand crimp tooling for loose contacts		Automatic crimp tooling for contacts on strip P100MAN		Extraction tooling
	Hand tools die set included	M8ND Die set (not included)	Left side applicator (not included)	Stripper unit	
24	Y16SCM2 (ratchet)	N24RT11	MLS0318B	SC10S1	RX2025GE1 or RX2025GE2
20	Y14SCM2 (not ratchet) Y14MTV (ratchet)	N20RT29	MLS0555A		
16M(L)11	Y16SCM2 (ratchet) Y14SCM2 (not ratchet)	N16RT26	MLS0356A		
16M(L)1	Y14SCM (ratchet) Y14MTV (ratchet)	N16RT24	MLS1579		
14	Y14SCM (ratchet) Y14MTV (ratchet)	N14RT13	MLS1047		

For detailed information on crimp tooling : See crimp tooling section