

Thick Film Chip Resistor – General Purpose

Features

- Small and light weight
- Excellent heat resistance and moisture resistance
- Suitable size and packaging for surface mount assembly
- RoHS Compliant

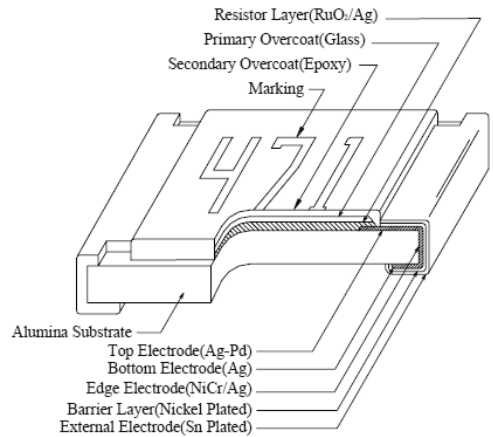

Applications

- For general purpose applications
- For laptop and notebook computer, memory module, digital camera and telecommunication equipment

Absolute Maximum Ratings & Characteristics

Product Number	mm	Tolerance	Power Rating @70°C	MAX Working Voltage	MAX Overload Voltage	TCR ppm/°C	Resistance Range	Rated Working Temperature
							RC2010	
						±100	10Ω ~ 1MΩ	
						±200	1.02MΩ ~ 10MΩ	

***Jumper**

Product Number	Jumper Rated Current	Resistance	Rated Working Temperature
RC2010	3.5A	50mΩ (max.)	-55°C~+155°C

Thick Film Chip Resistor - General Purpose

RC2010

Power Derating Curve

For resistors operate in the ambient temperature over 70°C, loading power ratio will de-rate in accordance with following curve.

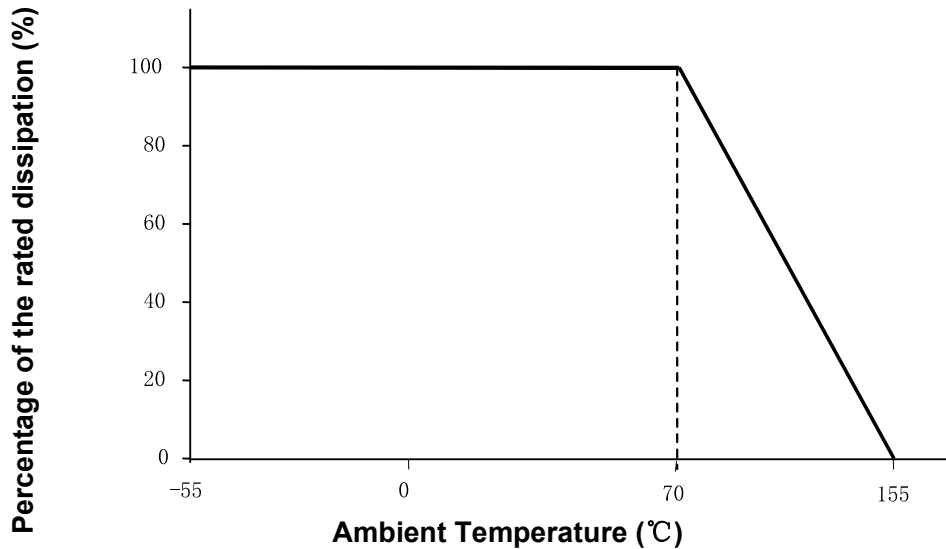

Max. Dissipation of rated power as a function of the ambient temperature

Soldering Condition

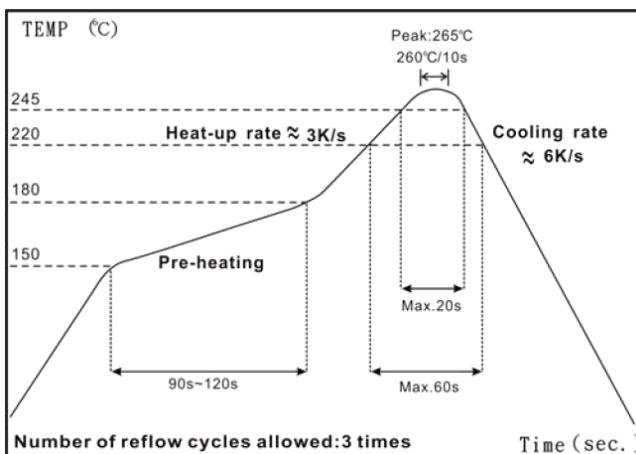

IR Reflow soldering

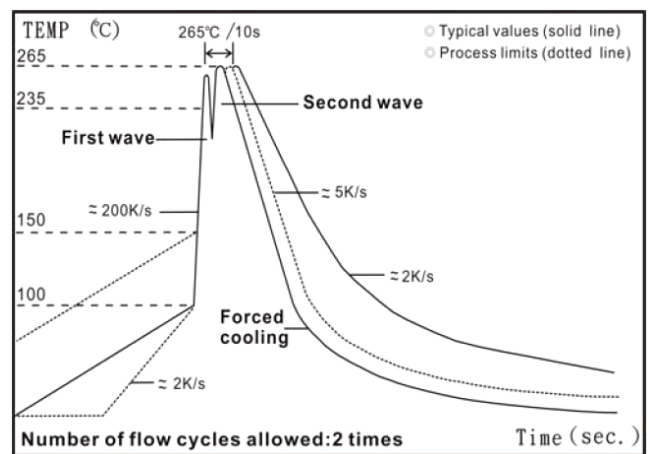

Wave soldering (flow soldering)

Thick Film Chip Resistor - General Purpose

RC2010

Dimensions (in mm)

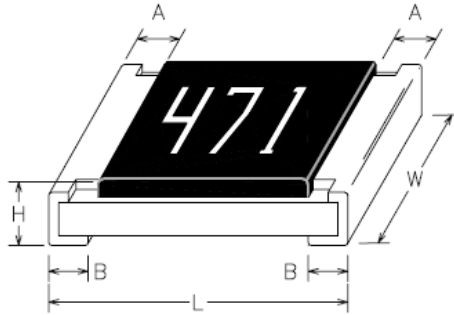

Product Number	mm	L	W	H	A	B	Average Weight
RC2010	5025	5.00 ± 0.20	2.50 ± 0.15	0.55 ± 0.10	0.60 ± 0.25	0.50 ± 0.20	23.887 mg

Marking

(1) ±5% Tolerance (J): 3 digits, the first two digits are significant figures; the third digit is number of zeros to follow. Letter "R" is as decimal point; Letter "0" for jumper.

(2) ±1% Tolerance (F): 4 digits, the first three digits are significant figures; the fourth digit is number of zeros. Letter "R" is as decimal point; Letter "0" for jumper.

Examples:

3 digits marking (±5%)



$$683 = 68 \times 10^3 \Omega$$

$$= 68000 \Omega = 68K\Omega$$

$$7R5 = 7.5 \Omega$$



Jumper

4 digits marking (±1%)



$$6812 = 681 \times 10^2 \Omega$$

$$= 68100 \Omega = 68.1K\Omega$$

Thick Film Chip Resistor - General Purpose

RC2010

Test and Requirements

Test Item	Test Method	Test Condition	Requirement		
			±1%	±5%	Jumper
Temperature Coefficient of Resistance(T.C.R.)	JIS C 5201 4.8 IEC 60115-1 4.8	-55°C~+155,20°C is the reference temperature	Within the specification		
Short Time Overload	JIS C 5201 4.13 IEC 60115-1 4.13	2.5 times RCWV or max. overload voltage for 5 seconds	±(1.0%+0.05Ω)	±(2.0%+0.05Ω)	<50mΩ
Insulation Resistance	JIS C 5201 4.6 IEC 60115-1 4.6	Max. overload voltage for 1 minute	≥10G		
Voltage Proof	JIS C 5201 4.7 IEC 60115-1 4.7	1.42 times RCWV (RMS) for 1 minute	no breakdown or flashover		
Substrate Bending Test	JIS C 5201 4.33 IEC 60115-1 4.33	Bending once with 5 seconds for 3 mm	±(1.0%+0.05Ω)	±(1.0%+0.05Ω)	<50mΩ
Resistance to soldering heat	JIS C 5201 4.18 IEC 60115 4.18	260±5°C for 10 seconds	±(0.5%+0.05Ω)	±(1.0%+0.05Ω)	<50mΩ
Leaching	JIS C 5201 4.18 IEC 60115 4.18	260±5°C for 60 seconds	no leaching		
Solderability	JIS C 5201 4.17 IEC 60115-1 4.17	245±5°C for 3 seconds.	>95% coverage		
Endurance at upper category temperature	JIS C 5201 4.23 IEC 60115-1 2.23.2	at +155°C for 1000 hrs	±(1.0%+0.05Ω)	±(1.5%+0.10Ω)	<50mΩ
Rapid change of temperature	JIS C 5201 4.19 IEC 60115-1 4.19	-55°C to +155°C, 5 cycles	±(0.5%+0.05Ω)	±(1.0%+0.05Ω)	<50mΩ
Damp heat with load	JIS 5201 4.24	40±2°C, 90~95% R.H. or max. working voltage for 1000 hrs with 1.5hrs "ON" and 0.5 hrs "OFF"	±(2.0%+0.10Ω)	±(3.0%+0.10Ω)	<100mΩ
Endurance	JIS C 5201 4.25 IEC 60115-1 4.25.1	70±2°C, RCWV or Max. working voltage for 1000 hrs with 1.5 hrs "ON" and 0.5 hrs "OFF"	±(2.0%+0.10Ω)	±(3.0%+0.10Ω)	<100mΩ

Note: RCWV: Rated Continuous Working Voltage.

$$RCWV = \sqrt{\text{Rated power (W)} \times \text{Resistance value (R)}}$$

Thick Film Chip Resistor - General Purpose

RC2010

Packing Information:

Carrier Tape Dimensions (in mm)

www.DataSheet4U.com

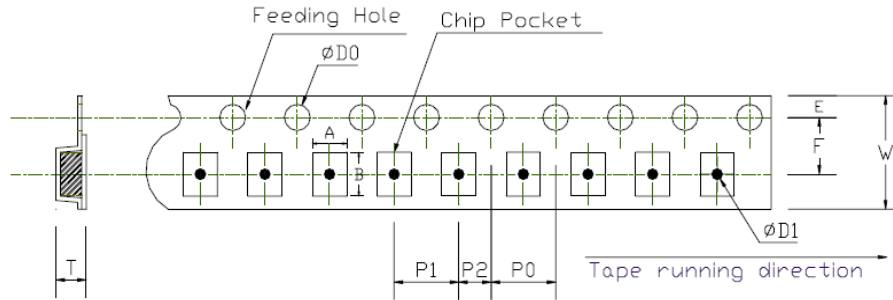

Type	A	B	W	E	F	P0	P1	P2	$\psi D0$	$\psi D0$	T
RC2010	2.80±0.2	5.50±0.2	12.0±0.3	1.75±0.1	5.5±0.05	4.0±0.1	4.0±0.1	2.0±0.05	1.5+0.1/-0	1.5+0.25/-0	Max1.2

Reel Dimensions (in mm)

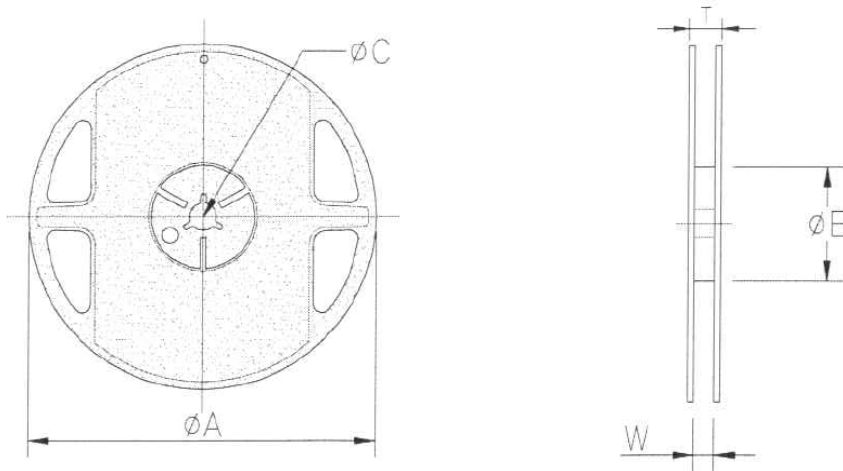

Reel Diameter	PCS per Embossed Tape	A	B	C	W	T
7"	4,000	180+0/-3	60+1/-0	13.0±0.2	13.0±0.5	15.4±1

Carton Information

PCS per Carton	Carton Size
192,000	400X400X200 (in mm)

Thick Film Chip Resistor - General Purpose

RC2010

How to Order

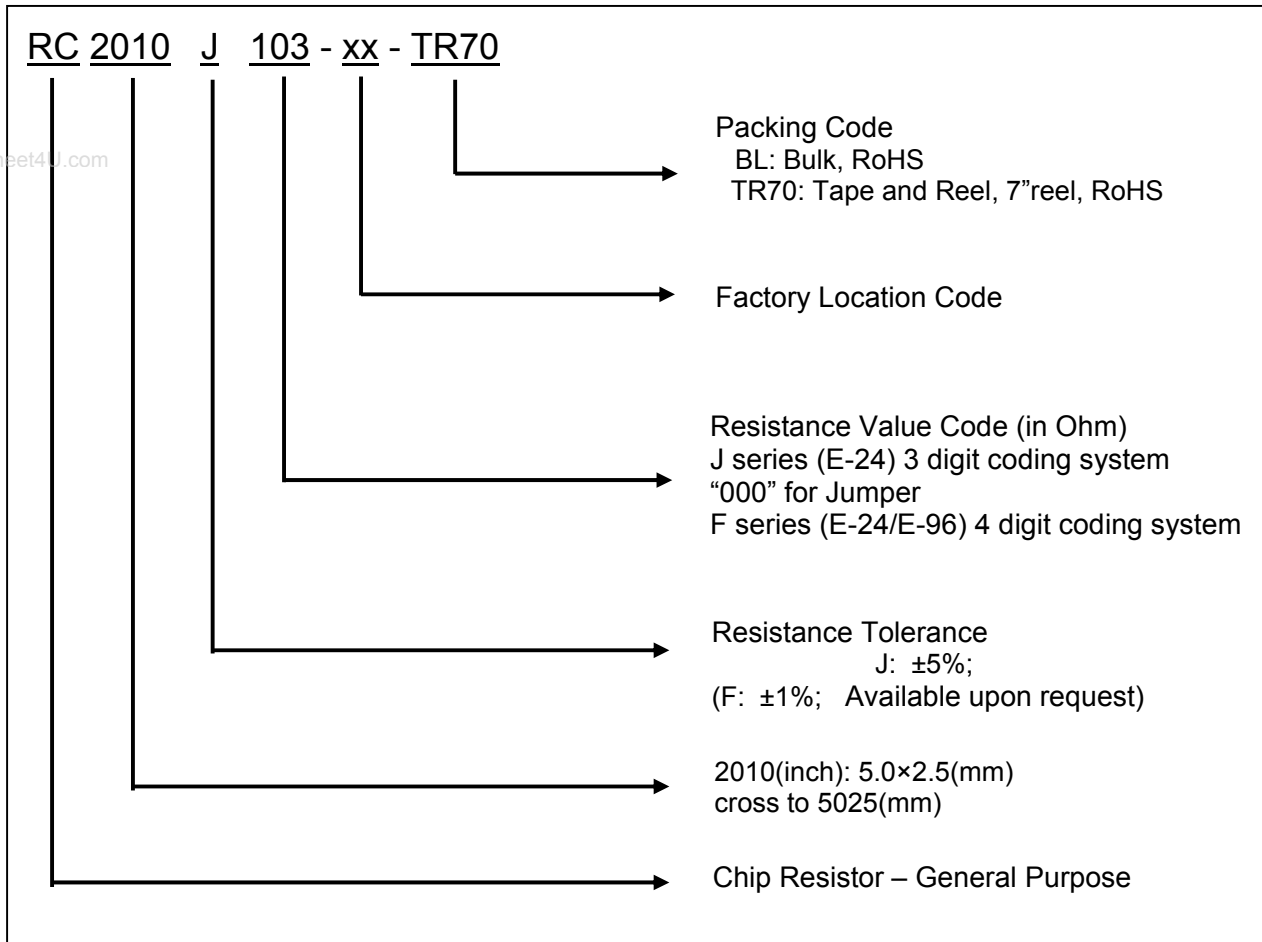

Thick Film Chip Resistor - General Purpose

RC2010

www.DataSheet4U.com

How to contact us:

US HEADQUARTERS

28040 WEST HARRISON PARKWAY, VALENCIA, CA 91355-4162

Tel: (800) TAITRON (800) 824-8766 (661) 257-6060

Fax: (800) TAITFAX (800) 824-8329 (661) 257-6415

Email: taitron@taitroncomponents.com

Http://www.taitroncomponents.com

TAITRON COMPONENTS MEXICO, S.A .DE C.V.

BOULEVARD CENTRAL 5000 INTERIOR 5 PARQUE INDUSTRIAL ATITALAQUIA, HIDALGO C.P.
42970 MEXICO

Tel: +52-55-5560-1519

Fax: +52-55-5560-2190

TAITRON COMPONETS INCORPORATED E REPRESENTAÇÕES DO BRASIL LTDA

RUA DOMINGOS DE MORAIS, 2777, 2.ANDAR, SALA 24 SAÚDE - SÃO PAULO-SP 04035-001 BRAZIL

Tel: +55-11-5574-7949

Fax: +55-11-5572-0052

TAITRON COMPONETS INCORPORATED, SHANGHAI REPRESENTATIVE OFFICE

METROBANK PLASA, 1160 WEST YAN'AN ROAD, SUITE 1502, SHANGHAI, 200052, CHINA

Tel: +86-21-5424-9942

Fax: +86-21-5424-9931