

RC6508

QAM IF Downconverter

Features

- Integrated IF Down Converter
- IF bandwidth from 30 MHz to 80 MHz
- Operating range between 8.5V to 13.2V
- 63dB peak conversion gain from IF to baseband
- 40dB minimum AGC range
- Simple interface to SAW filter and A/D converter
- Gain control minimizes noise figure and distortion
- Tuner control feature interfaces with variety of tuners
- Industry standard 24 Lead SSOP package

Applications

- Digital Set-top Receivers
- Cable Modems

Description

The RC6508 simplifies the front-end design of cable modem and set-top receivers. It is a cost-effective solution, since it integrates IF amplifier, AGC, mixer, amplifier, tuner AGC, VCO, XTAL OSC, and bandgap reference on a single chip. The RC6508 downconverts the IF signal to baseband signal for cable modem and set top receivers. The baseband signal can be digitized and decoded with an external A/D converter and a custom DSP demodulator. The input can directly interface to a SAW filter and maintain a low noise figure. The gain can be controlled over a 40dB range through an external analog input signal. The gain reduction is done in two stages with minimum noise figure and signal distortion. The IF output is then down converted and filtered using a double balanced mixer. The output can be further filtered with an external filter prior to A/D conversion. The RC6508 has an added feature that it provides an optimum tuner AGC control voltage which is used to control the front end tuner gain. The IF and Mixer section works at 9V and the oscillator works on 5V supply. The RC6508 is available in a 24 Lead SSOP package.

Block Diagram

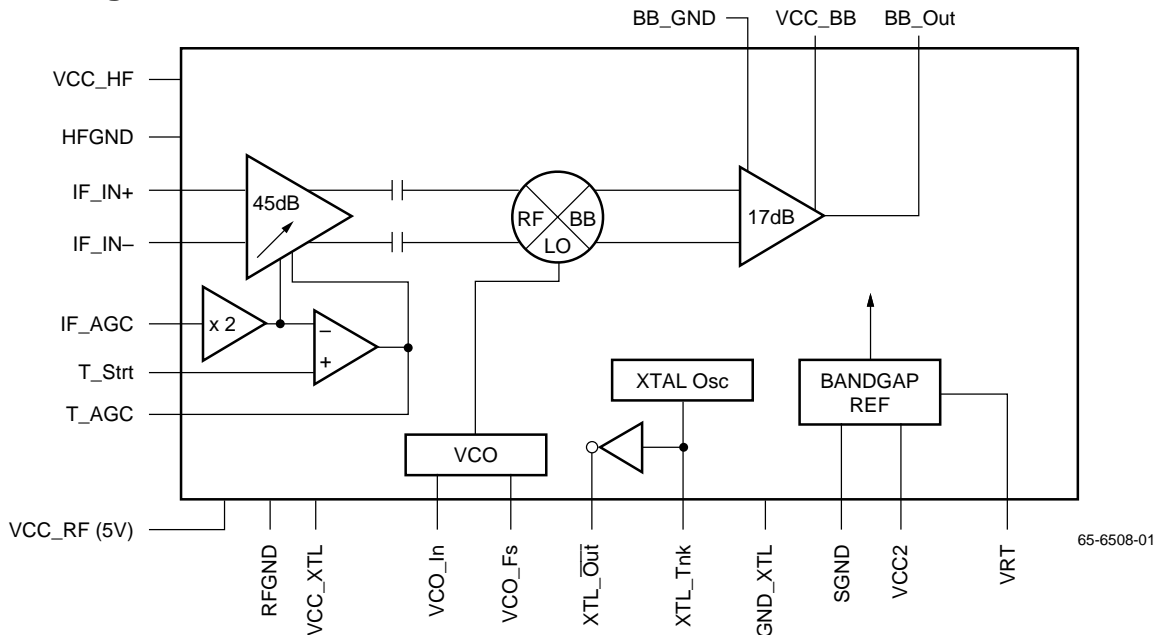

Functional Description

The RC6508 shown in the block diagram performs all the IF and baseband signal conversion with the minimal external components. It consists of three general sections:

- IF Gain Section
- IF Down Conversion and Frequency Synthesis
- Reference Voltage

IF Gain Section

This is the first stage of the IF-to-Baseband conversion. The IF input signal is fed into a variable gain control amplifier that is capacitively coupled to the subsequent stages. The gain control amplifier has stabilized gain over temperature and supply variations. The amplifier gain is directly proportional to the IF_AGC voltage. The gain in various stages is not reduced at the same time in order to minimize the noise figure degradation. The transition point is set by the voltage on T_Strt pin. T_strt sets the T_AGC trigger to control the front end tuner gain.

IF Down Conversion and Frequency Synthesis

This is the second stage of the IF-to-Baseband conversion. It consists of a double balanced linear mixer. The output of the front end gain stage is capacitively coupled to the input (RF port) of the mixer. The LO signal for the mixer can be directly driven or synthesized with the Voltage Controlled Oscillator (VCO). This section has also a crystal oscillator that can be used to generate a master clock for the frequency synthesis. The mixer translates the signal to a second IF frequency equal to the symbol rate and passes through an amplifier. The final output is a baseband signal, BB_Out. This signal can be further filtered externally before connecting it to an external ADC and QAM demodulator.

Reference Voltage

The RC6508 has a built-in 2.0V reference with capability of driving 10mA load and can be used to set up A/D reference.

Pin Assignments

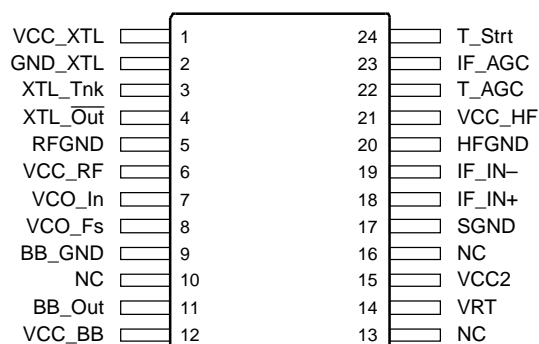

65-6508-02

Pin Descriptions

Pin Name	Pin Number	Pin Function Description
BB_GND	9	Ground Connection.
BB_Out	11	Baseband Voltage output.
GND_XTL	2	Crystal Oscillator Ground.
HFGND	20	Analog Ground Connection.
IF_AGC	23	Input Voltage for IF Front End Gain Control.
IF_IN+,IF_IN-	18,19	IF inputs.
NC	10,13,16	No Connection.
RFGND	5	Ground Connection for High Frequency Mixed Signal Sections.
SGND	17	Analog Ground Connection.
T_AGC	22	Output Voltage for Tuner Gain Control.
T_Strt	24	Threshold Voltage Input for Starting Tuner Gain Control.
VCC_BB	12	Baseband Supply Voltage, typically 9V.
VCC2	15	Analog Supply Voltage (9V).
VCC_HF	21	Analog Supply Voltage (9V).
VCC_RF	6	Supply Voltage (5V) for High Frequency Mixed Signal Sections.
VCC_XTL	1	Supply Voltage for Crystal Oscillator.
VCO_Fs	8	VCO External Frequency Select Circuit Connection.
VCO_In	7	VCO Input, can be used for directly feeding external LO.
VRT	14	Output reference voltage for top of A/D input range.
XTL_Out	4	Crystal Oscillator Output.
XTL_Tnk	3	Crystal Oscillator Frequency Select Circuit Connection.

Absolute Maximum Ratings

Parameter		Min.	Typ.	Max.	Units
IF_IN+, IF_IN-, IF_AGC, T_Strt	Input Voltages	GND – 0.3		VCC + 0.3	V
VCC_RF, VCC_BB, VCC_HF, VCC2, VCC_XTL	Analog Supply Voltages			13.5	V
Tstg	Storage Temperature	-40		125	°C

Operating Conditions

Parameter		Min.	Typ.	Max.	Units
VCC	Analog Supply Voltage	8.5	9	13.2	V
VCC_RF	Supply Voltage for IF and Mixer	4.75	5	5.25	V
VCC_XTL	Supply Voltage for XTLOSC and VCO				
T	Temperature	0		70	°C

DC Electrical Characteristics

VCC_RF, VCC_XTL = 5V; VCC_HF, VCC_BB, VCC2 = 9V; T_A = 0 to 70°C, unless otherwise specified.

Parameter	Conditions	Min.	Typ.	Max.	Units	
PWIF	Power Consumption in IF		0.4	0.5	W	
ICCHF	Front End Supply Current	9V Supply	20	25	mA	
		12V Supply	27	35		
ICCBB	Back and Baseband Current	9V Supply	21	25	mA	
ICCRF	RF Supply Current	5V Supply	6	10	mA	
VRT	Reference Output Voltage		1.95	2.05	2.15	V
ΔVBB _o	Baseband DC Output Swing		3.5			V _{pp}
Tagc_hi	Tuner AGC for Maximum Gain	IF_AGC = 5V		7.5		V
Tagc_lo	Tuner AGC for Minimum Gain	IF_AGC = 2V		2		V

AC Electrical Characteristics VCC_XTL, VCC_RF = 5V; VCC_HF, VCC_BB = 9V; IF_AGC = 2V; T_{sr} = 5V; T_A = 0 to 70°C, unless otherwise specified.

Parameter	Conditions	Min.	Typ.	Max.	Units	
ZIFin	AC Input Impedance	@43.75MHz	2		KΩ	
CIFin	AC Equivalent Input Cap	IF_IN±		6	pF	
Vis	Input Sensitivity at Maximum Gain	V _{agc} =2.5V		250	μV	
IMD3	Two Tone Intermodulation	f1/f2 = 43.75/42.75 MHz, IF_IN = -16dBm, VCO_IN = 0.1V _{pp} , LO = 38.75MHz ¹		45		dB
G	IF to Baseband Gain	IF_AGC = 2V	35	40		dB
NF	Noise Figure (Maximum Gain)			9		dB
Ragc	AGC Gain Range	IF_AGC = 0V-4V	40	43		dB
Sagc	AGC Sensitivity Average Slope	T_Strt = 5V, F_AGC = 0.8V-4V		10		dB/V
BW_IF	IF Bandwidth	0.1dB for 10MHz bands	30	43.75	75	MHz
		0.1dB for 5MHz bands	30		80	
fLO	Down Conversion Frequency	VCO-IN=0.1V _{pp}			100	MHz
Φ _n LO	VCO Phase Noise	@ ±10KHz offset			-80	dBc/Hz
Φ _n XTL	XTAL OSC Phase Noise	@ ±3KHz offset			-80	dBc/Hz

Note:

1. With the application of antialiasing filter as load.

Typical Performance Characteristics

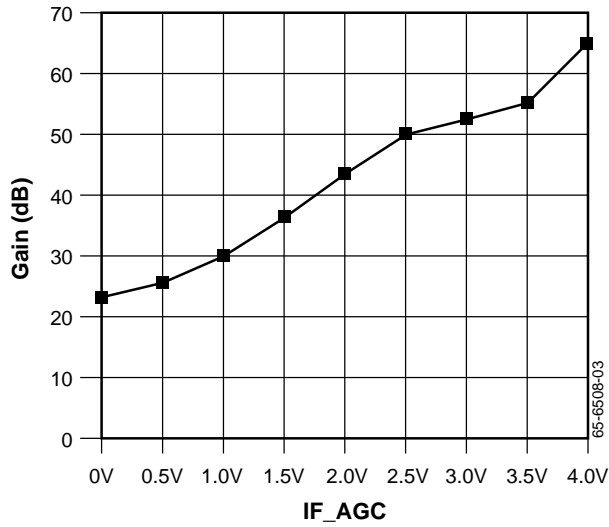

Figure 1. Typical IF_AGC Control Characteristics

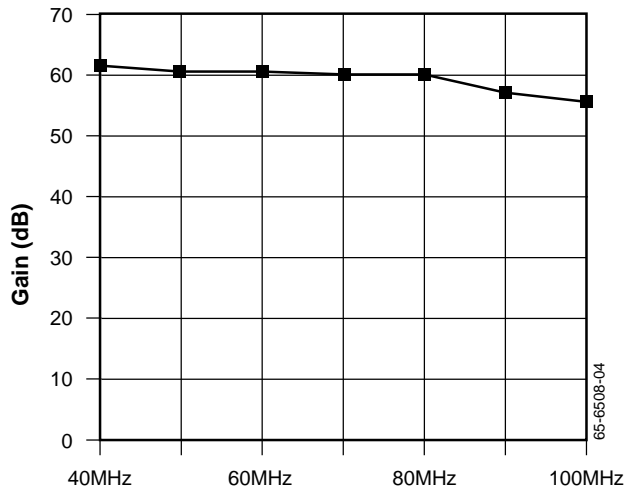

Figure 2. IF Input Bandwidth

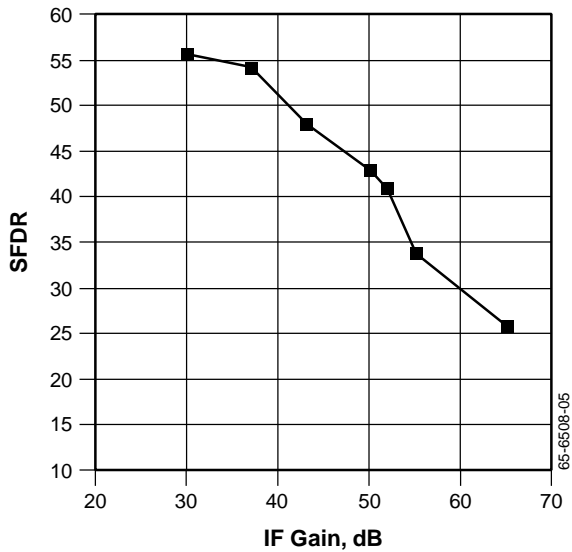

Figure 3. SFDR vs. RC6508/TMC1175AM7C40 (Raytheon Demo Board with 64 QAM demodulator)

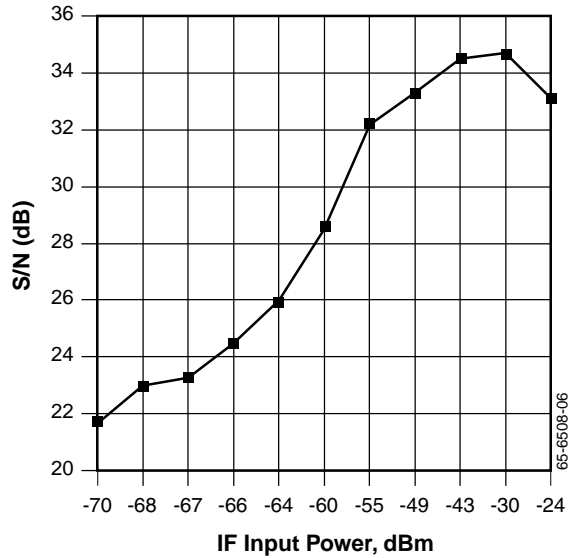

Figure 4. S/N vs. IF Input Power RC6508/TMC1175AM7C40 (A/D IN = 2Vpp) (Raytheon Demo Board with 64 QAM demodulator)

Applications

The RC6508 is designed to down convert QAM IF signals. It interfaces easily with Raytheon Electronic's TMC1175A A/D converter and a DSP.

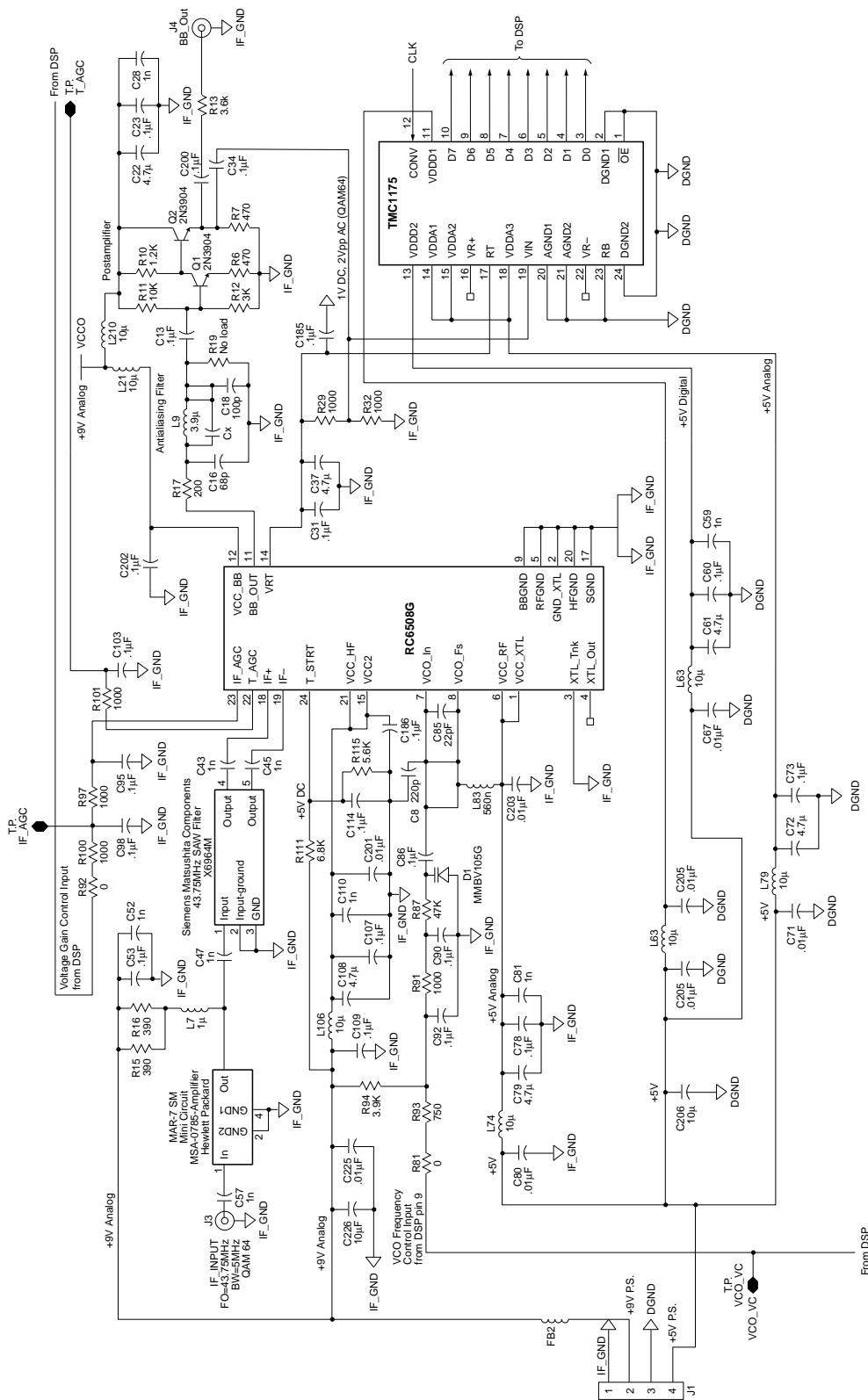
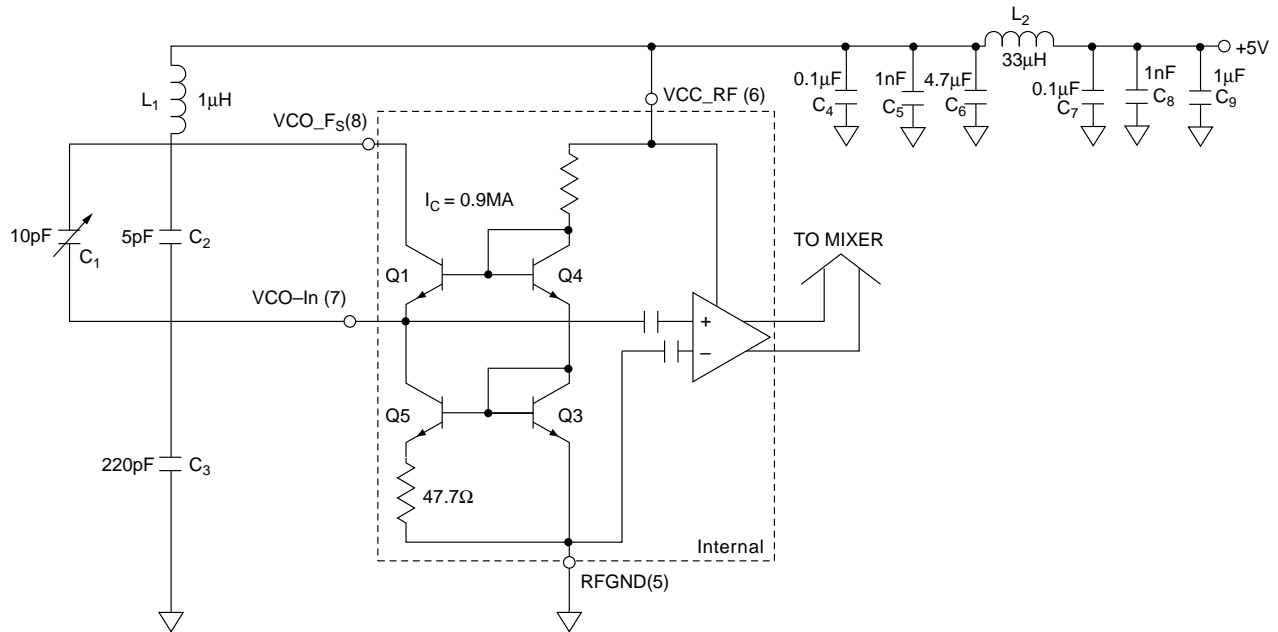

Figure 5. Application of RC6508 in Cable Modem Receivers (Raytheon Demo Board with 64 QAM Demodulator)

VCO Internal Schematic



The VCO can be designed as a Colpitts oscillator. The above circuit application shows VCO with adjustable typical value of 38.75 MHz. The frequency is controlled by the external resonance circuit. The oscillating transistor is Q1 in common

base configuration. To inject signal in the mixer in place of LO, the VCO_Fs must be open. The signal on the pin VCO_In should be under 100mVp-p and AC coupled.

Crystal Oscillator Internal Schematic

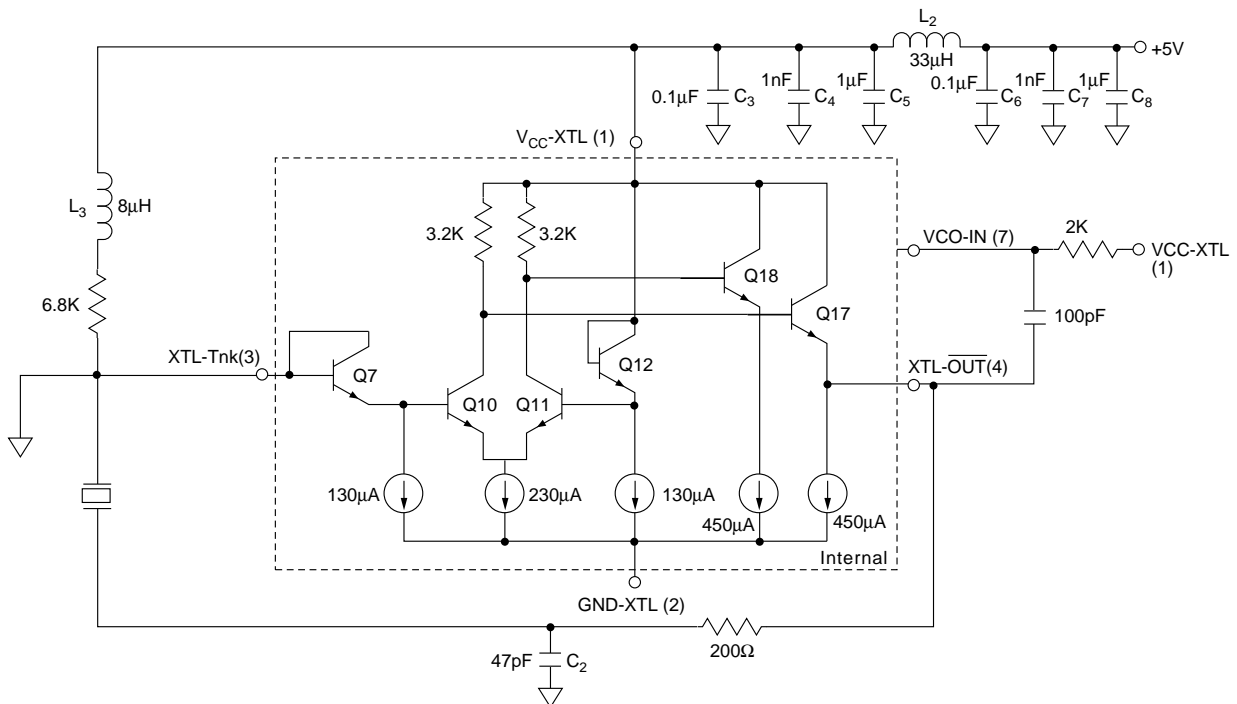

The crystal oscillator is an ECL inverter. It is necessary to bias the XTl-Tnk with a choke to 5V VCC_XTL power supply. The output is about 0.7V DC lower than VCC_XTL with

an approximate swing of 0.5Vpp at the output. If the oscillator is not used, it is good to ground XTl_Tnk pin.

Notes:

Notes:

Notes:

Mechanical Dimensions

24 Lead SSOP Package (5.3mm Body Width)

Symbol	Inches		Millimeters		Notes
	Min.	Max.	Min.	Max.	
A	—	.0.78	—	2.00	
A1	.002	—	0.05	—	
A2	.065	.073	1.65	1.85	
b	.010	.015	0.22	0.38	
c	.0035	.010	0.09	0.25	
D	.311	.335	7.90	8.50	
E	.291	.323	7.40	8.20	
E1	.197	.220	5.00	5.60	
e	.026 BSC		0.65 BSC		
L	.022	.037	0.55	0.95	
N	24		24		
α	0°	8°	0°	8°	
ccc	—	.004	—	0.10	

Notes:

1. Dimensioning and tolerancing per ANSI Y14.5M – 1982.
2. "D" and "E" do not include mold flash. Mold flash or protrusions shall not exceed .006 inch (0.15mm).
3. "L" is the length of terminal for soldering to a substrate.
4. Terminal numbers are shown for reference only.
5. "C" dimension does not include solder finish thickness.
6. Symbol "N" is the maximum number of terminals.

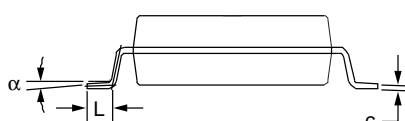
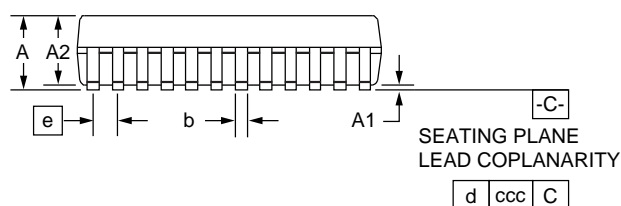
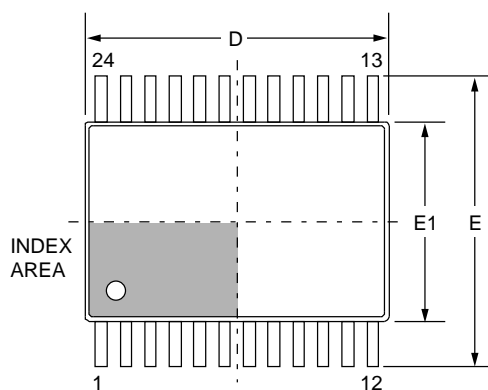

Ordering Information

Product Number	Temperature Range	Screening	Package	Package Marking
RC6508G	0°C–70°C	Commercial	24 Lead SSOP	RC6508G

The information contained in this data sheet has been carefully compiled; however, it shall not by implication or otherwise become part of the terms and conditions of any subsequent sale. Raytheon's liability shall be determined solely by its standard terms and conditions of sale. No representation as to application or use or that the circuits are either licensed or free from patent infringement is intended or implied. Raytheon reserves the right to change the circuitry and any other data at any time without notice and assumes no liability for errors.

LIFE SUPPORT POLICY:

Raytheon's products are not designed for use in life support applications, wherein a failure or malfunction of the component can reasonably be expected to result in personal injury. The user of Raytheon components in life support applications assumes all risk of such use and indemnifies Raytheon Company against all damages.

Raytheon Electronics
Semiconductor Division
350 Ellis Street
Mountain View CA 94043
650.968.9211
FAX 650.966.7742