



Power Transistors

RCA411

High-Voltage, High-Power Silicon N-P-N Power Transistor

For Switching and Linear Applications in Military, Industrial, and Commercial Equipment

Features:

- Maximum safe-area-of-operation curves
- Low saturation voltage: $V_{CE(sat)} = 0.8 \text{ V (max.)}$
- High voltage rating: $V_{CEO(sus)} = 300 \text{ V}$
- High dissipation rating: $P_T = 125 \text{ W}$

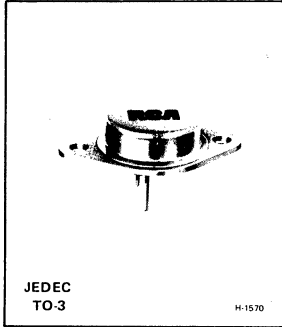

RCA-411 is an epitaxial silicon n-p-n power transistor utilizing a multiple-emitter-site structure. This device employs the popular JEDEC TO-3 package.

Featuring high breakdown-voltage ratings and low saturation-

current values, the RCA-411 is especially suitable for use in inverters, deflection circuits, switching regulators, high-voltage bridge amplifiers, ignition circuits, and other high-voltage switching applications.

MAXIMUM RATINGS, Absolute-Maximum Values:

COLLECTOR-TO-BASE VOLTAGE, V_{CB0}	300 V
COLLECTOR-TO-EMITTER SUSTAINING VOLTAGE: With base open, $V_{CEO(sus)}$	300 V
EMITTER-TO-BASE VOLTAGE, V_{EBO}	5 V
COLLECTOR CURRENT: Continuous, I_C	7 A
Peak	10 A
BASE CURRENT (Continuous), I_B	2 A
TRANSISTOR DISSIPATION, P_T : At case temperatures up to 25°C and V_{CE} up to 75 V	125 W
At case temperatures up to 25°C and V_{CE} above 75 V	See Fig. 2.
At case temperatures above 25°C and V_{CE} above 75 V	See Figs. 1 & 2.
TEMPERATURE RANGE: Storage & Operating (Junction)	-65 to +200 °C

PIN TEMPERATURE (During Soldering):

At distances $\geq 1/32$ in. (0.8 mm) from case for 10 s max.	230 °C
--	--------

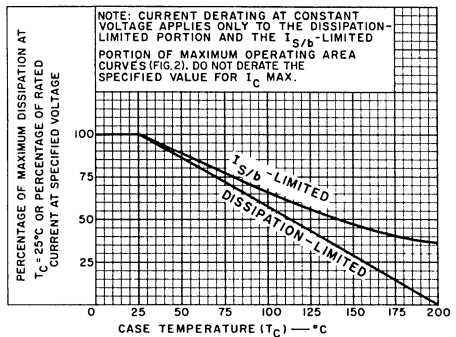

92CS-19296

Fig. 1—Dissipation and current derating curves.

ELECTRICAL CHARACTERISTICS, Case Temperature (T_C) = 25°C Unless Otherwise Specified

Characteristic	Symbol	Test Conditions				Limits			Units
		DC Voltage (V)		DC Current (A)		Min.	Typ.	Max.	
		V_{CE}	V_{BE}	I_C	I_B				
Collector-Cutoff Current: With base open	I_{CEO}	300				—	—	0.25	mA
With base-emitter junction reverse-biased	I_{CEV}	300	1.5			—	—	0.25	
With base-emitter junction reverse-biased & $T_C = 125^\circ\text{C}$	I_{CEV}	300	-1.5			—	—	0.5	
Emitter-Cutoff Current	I_{EBO}		-5			—	—	5.0	mA
DC Forward-Current Transfer Ratio	h_{FE}	5		1.0 ^a		30	—	90	
		5		2.5 ^a		10	—	—	
Collector-to-Emitter Sustaining Voltage: With base open (See Figs. 3 & 4.)	$V_{CEO(sus)}^b$			0.1		300 ^b	—	—	V
Base-to-Emitter Saturation Voltage	$V_{BE(sat)}$			1.0 ^a	0.1	—	0.9	1.5	V
Collector-to-Emitter Saturation Voltage	$V_{CE(sat)}$			1.0 ^a	0.1	—	0.2	0.8	V
Second-Breakdown Collector Current: (With base forward-biased) Pulse duration (non-repetitive) = 1 s	$I_{S/b}^c$	150				0.3	—	—	A
Gain-Bandwidth Product	f_T	10		0.2		—	2.5	—	MHz
Switching Time: ($I_{B1} = 0.1 \text{ A}$, $I_{B2} = -0.5 \text{ A}$)									μs
Rise (See Figs. 10, 12, & 13.)	t_r			1.0		—	0.35	—	
Storage (See Figs. 11, 12, & 13.)	t_s			1.0		—	1.4	—	
Fall (See Figs. 9, 12, & 13.)	t_f			1.0		—	0.15	—	
Thermal Resistance (Junction-to-Case)	$R_{\theta/JC}$	10		5		—	—	1.4	$^\circ\text{C/W}$

^a Pulsed; pulse duration $\leq 350 \mu\text{s}$, duty factor = 2%.

^b CAUTION: The sustaining voltage $V_{CEO(sus)}$ MUST NOT be measured on a curve tracer. The sustaining voltage should be measured by means of the test circuit shown in Fig. 3.

^c $I_{S/b}$ is defined as the current at which second breakdown occurs at a specified collector voltage with the emitter-base junction forward-biased for transistor operation in the active region.

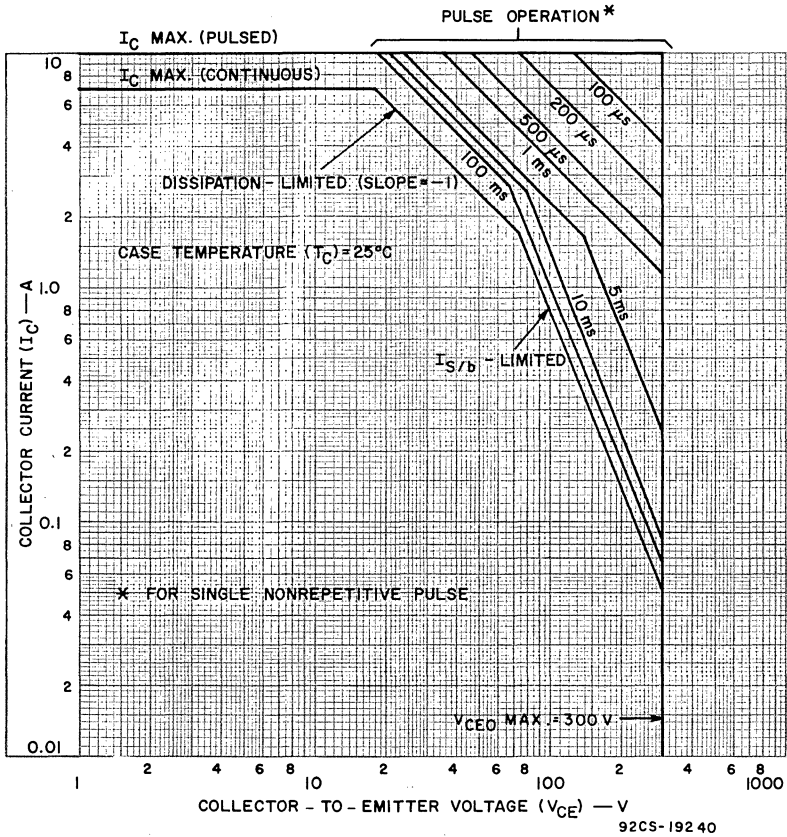

Fig.2—Maximum operating areas.

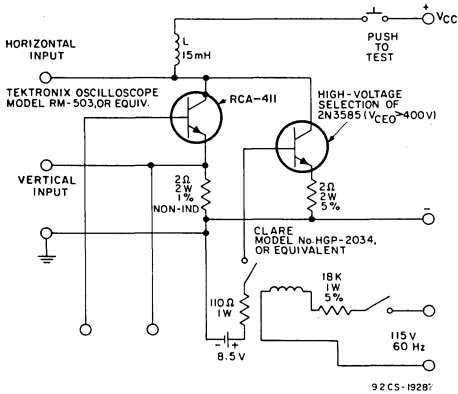

Fig.3—Circuit used to measure sustaining voltage, $V_{CE0}(sus)$.

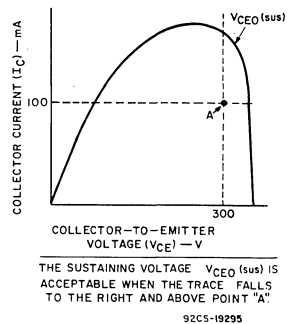

Fig.4—Oscilloscope display for measurement of sustaining voltage (test circuit shown in Fig.3).

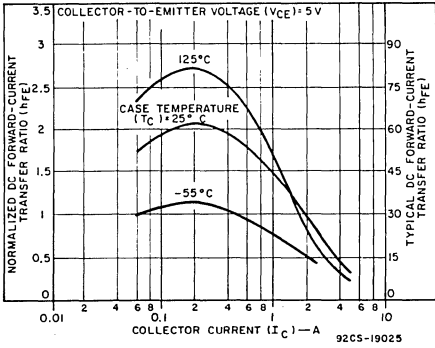

Fig. 5—Typical dc beta characteristics.

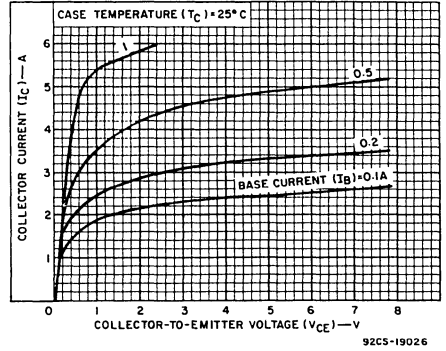

Fig. 6—Typical output characteristics.

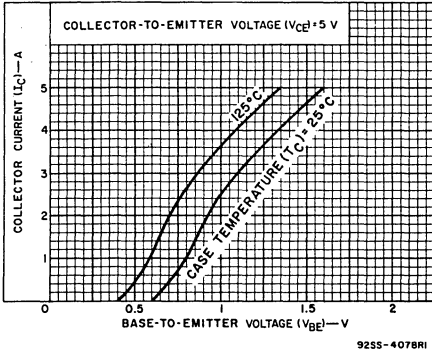

Fig. 7—Typical transfer characteristics.

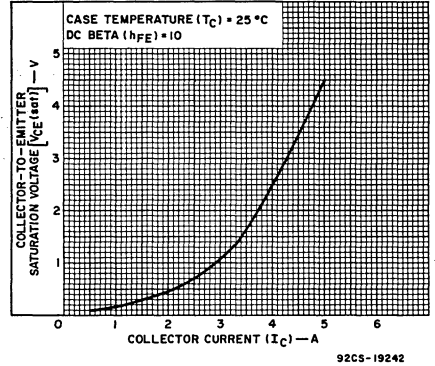

Fig. 8—Typical saturation voltage characteristic.

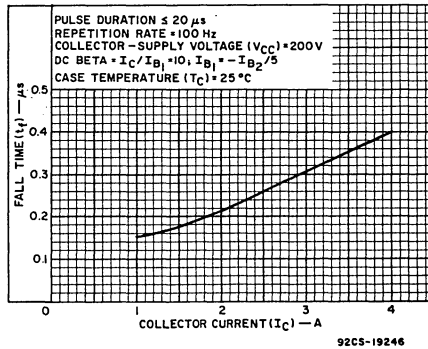

Fig. 9—Typical fall time vs. collector current.

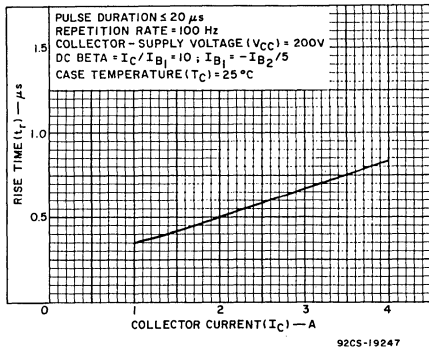

Fig.10—Typical rise time vs. collector current.

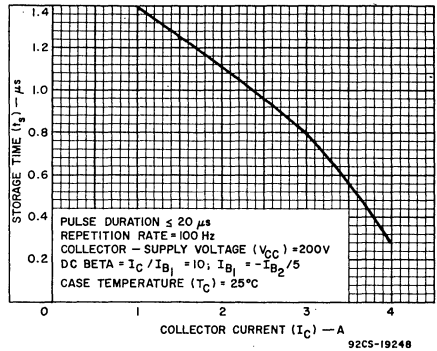
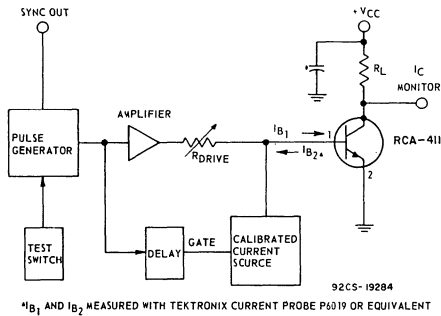

Fig.11—Typical storage time vs. collector current.



* I_{B1} and I_{B2} MEASURED WITH TEKTRONIX CURRENT PROBE P4019 OR EQUIVALENT

Fig.12—Circuit used to measure switching times.

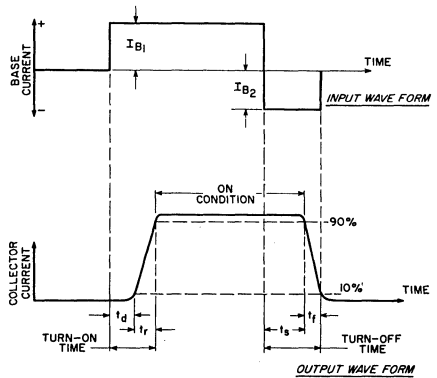

Fig.13—Phase relationship between input and output currents showing reference points for specification of switching times. Test circuit shown in Fig.12).

TERMINAL CONNECTIONS

- Pin 1 — Base
- Pin 2 — Emitter
- Mounting Flange, Case — Collector