

DATE OF ISSUE	SPECIFICATIONS	SPEC. -CD1076
Mar. 18. 2004		1/8

- ARTICLE : LED SEGMENT DISPLAY UNIT
- TYPE : RCN-SDA03R3NL
- OUTLINE : This is a Pb free, surface-mounting product, a hollow type with height of 8.0mm (0.3 inches) red LED is used, and with 1-figure number display character common to an anode.

4. MAXIMUM RATINGS T a = 2 5 ° C (per segment)

Item	Symbol	Rating	Unit
Forward direct current	I _F	20	mA
Reverse voltage	V _R	5	V
Storage temperature	T _{s t g}	-40 ~ +80	°C
Operating temperature	T _{o p r}	-30 ~ +70	°C
Solder temperature	T _{s o l}	350 within 3 sec.	°C

5. ELECTRO-OPTICAL CHARACTERISTICS T a = 2 5 ° C (per segment)

		RCN-SDA03R3NL				
Item	Symbol	Condition	MIN	TYP	MAX	Unit
Forward voltage	V _F	I _F =10mA	SEG	1.90	2.40	V
			DP	1.90	2.40	
Reverse current	I _R	V _R =4V			100	μA
Luminous intensity	I _v	I _F =10mA	SEG	0.7	2.0	mcd
			DP	0.18	0.5	
Peak emission wavelength	λ _P	I _F =10mA		632		nm
Spectra half-width	Δλ	I _F =10mA		35		nm

6. CIRCUIT DIAGRAM / TERMINAL CONNECTION

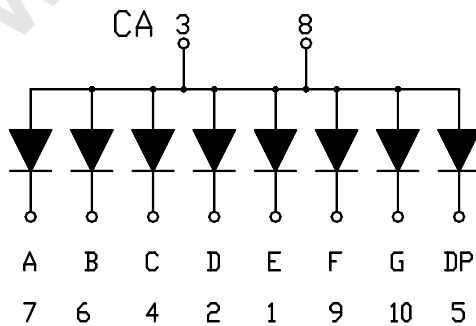

No.	FUNCTION
1	Cathode E
2	Cathode D
3	Anode COM
4	Cathode C
5	Cathode D.P
6	Cathode B
7	Cathode A
8	Anode COM
9	Cathode F
10	Cathode G

APPD.	CHK.	DESIGN	TRACE	OKAYA ELECTRIC INDUSTRIES CO.,LTD.

DATE OF ISSUE	SPECIFICATIONS	SPEC. -CD1076
		2/

7. EXTERNAL DRAWING

Unit : mm

Tolerance without specification : ± 0.3

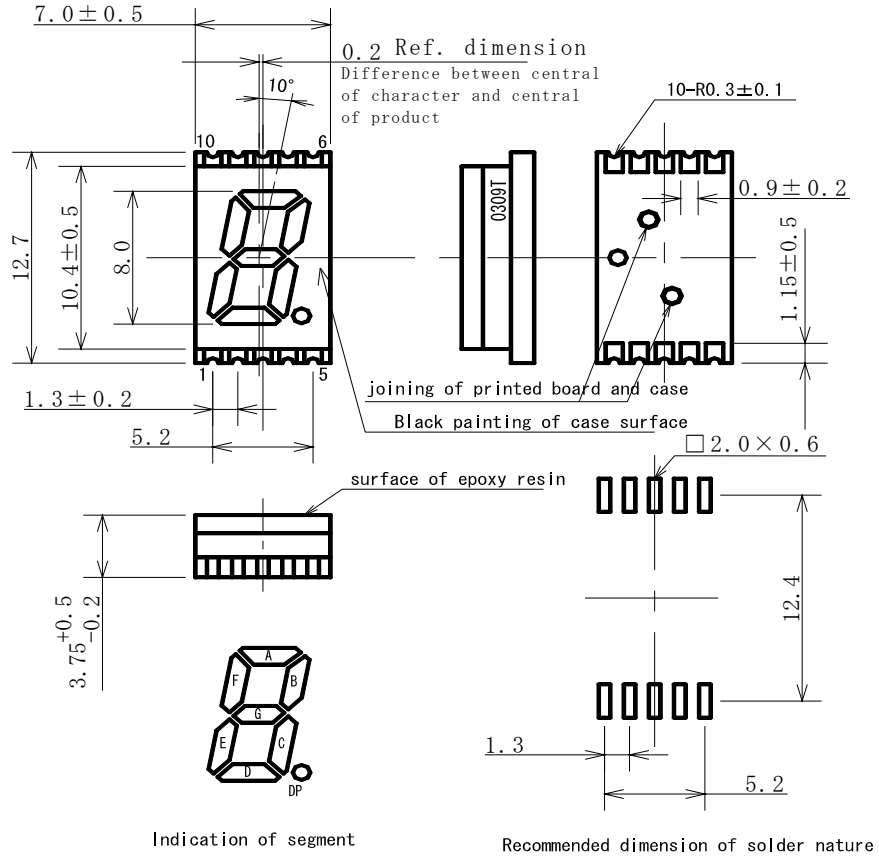

	Item	Material	Quantity
1	LED	GaAsP	8
2	Resin case	PPA	1
3	Printed board	CEM-3	1
4	Surface of case	Epoxy	—

8. SHIPMENT INSPECTION

8-1 Application standard I S O 2 8 5 9 - 1

8-2 Sampling system and standard

Normal Inspection	1-time sampling	standard II
A Q L	heavy defect	0. 4 %
	light defect	2. 5 %
	fine defect	6. 5 %

APPD.	CHK.	DESIGN	TRACE	OKAYA ELECTRIC INDUSTRIES CO.,LTD.

DATE OF ISSUE		SPECIFICATIONS		SPEC. -CD1076	
				3/	
8-3 Inspection item, judgment standard, and defect classification					
No.	Inspection item	Judgement system			Defect classification
1	open	consider as defect for those not turned on.			Heavy defect
2	short	consider as defect for those not turned on. consider as defect for those carries out simultaneous lighting			
3	Luminescence color	consider as defect for those not a regular luminescence color			
4	Different model mixing	consider as defect for those other models are mixing			
5	Marking	consider as defect for those with wrong marking or without marking			
6	Insufficient quantity	consider as defect for those with insufficient of product quantity.			
7	Characteristics	consider as defect for those not satisfied with the specification of electrical property. consider as defect for those luminous intensity not satisfied of the minimum value of specification.			Light defect
8	Appearance	consider as defect for those appearance not satisfied to the specification size.			
9	Color tone	consider as defect for those color tone different between segments.			
10	Garbage	consider as defect when garbage or decimal point as mentioned below mixing in a segment • Black garbage exceeding diameter of 0.3mm • White garbage exceeding diameter of 0.4mm • Thread garbage exceeding of 3.0mm			Fine defect
11	Air bubbles	air bubbles in the luminescence surface of product. consider as defect when exceeding 2 places of dia.0.3mm consider as fine product when air bubbles are on the side of the product.			
12	Printing	a crack in the printing part of the reflective board surface consider as defect when exceeding 2 places of 0.2mm × 3.0mm. separation in the printing part of the reflective board surface consider as defect when exceeding 2 places of dia.3mm			
13	Surface crack	a crack in a luminescence side of product consider as defect when places on a plate and the float of a product exceeds 0.3mm			
14	Resin adhesion	in which resin adhered to the back of the product consider as defect when places on a plate and the float of a product exceeds 0.3mm			
15	Segment shape	thick or narrow changes in a part of segment consider as defect when exceeding 0.2mm			
16	Resin barricade	consider as defect when the barricade exceeding tolerance size of a substrate.			
APPD.	CHK.	DESIGN	TRACE	OKAYA ELECTRIC INDUSTRIES CO.,LTD.	

DATE OF ISSUE	SPECIFICATIONS	SPEC. -CD1076
		4/

9. PACKING FORM

(1) Taping specifications

Lead Tape :

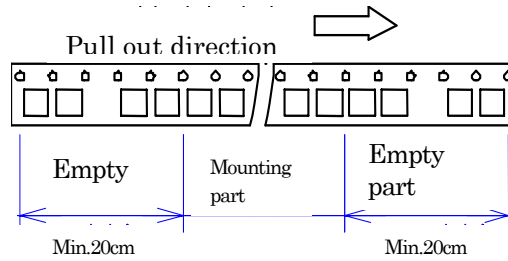

Tape exfoliation intensity : 0.1~0.8N

Tape sending speed : 5mm/s



Tape bending intensity : If a tape is bent in the radius of 50mm or less, a cover tape may separate.

Connection of a tape : There should be no connection of the cover tape and carry tape within 1 reel

Packing quantity : Standard quantity considers as 1,400 piece / reel.

Others : The omission of the product in the product enclosure part of a mounting part is taken as less than three continuation.

The product contained should move easily in each receipt hole

Adhesion on the cover tape of a product is not allowed.

APPD.	CHK.	DESIGN	TRACE	OKAYA ELECTRIC INDUSTRIES CO.,LTD.

DATE OF ISSUE	SPECIFICATIONS	SPEC. -CD1076
		5/

(2) Indication of label

TYPE	← Indication of product name (model)
LOT NO.	← Indication of lot
QUANTITY	← Indication of quantity
DATE	
NOTE	
OKAYA ELECTRIC INDUSTRIES CO. , LTD	

Indication of lot :

example) 0 3 0 9 T

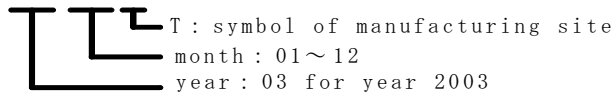

(3) Prevention-of-moisture

Packing by the aluminum pack is performed in order to avoid the moisture absorption under shipping and storage of the product.

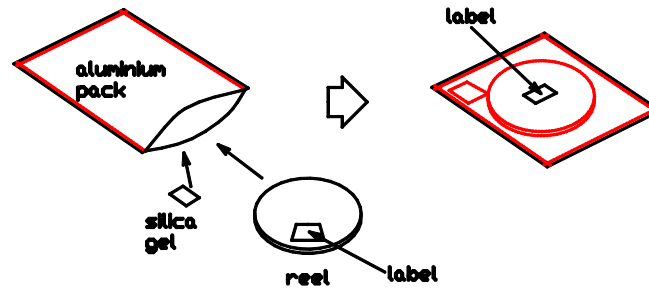

Storage conditions.

Please keep and manage with the following conditions after open.

- keep it in the place by which humidity-temperature management was carried out.
- keep it in a dry box.
- seal and keep with commercial silica, drier etc.
- keep it neither in a place with water leaking, nor the place where expose to direct rays hit.
- since a rapid temperature change may generates dew condensation, oxidization and corrosion etc, please keep it in a place with low temperature change.
- do not apply direct load at the time of storage.
- keep it neither in the place with poisonous gas (especially corrosive gas), nor a place with dirt.

APPD.	CHK.	DESIGN	TRACE	OKAYA ELECTRIC INDUSTRIES CO.,LTD.

DATE OF ISSUE	SPECIFICATIONS	SPEC. -CD1076
		6/

(4) Shape and reference dimension of tape

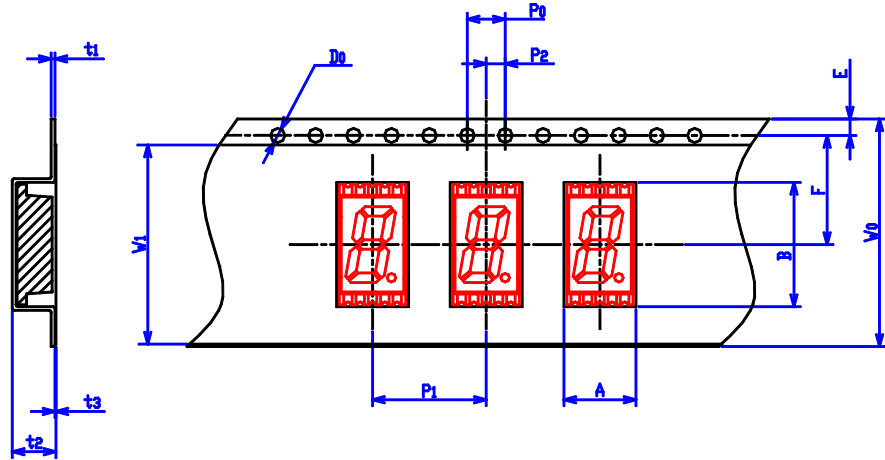

Item	Sym-bol	Reference dimension (mm)	Remarks	
Dent hole for product insertion	Vertical	A	7.6	The internal size excluding the corner R section
	Horizontal	B	13.1	The internal size excluding the corner R section
	Pitch	P 1	12.0	
Round sending hole	Major axis	D0	1.5	
	pitch	P 0	4.0	accumulation tolerance ±0.5mm/ 10 pitch
	position	E	1.75	Distance between tape end and sending hole
Distance between central lines	Vertical direction	P 2	2.0	Distance between dent hole and central line of round sending hole.
	Horizontal direction	F	11.5	Distance between dent hole and central line of round sending hole.
Cover tape	Width	W 1	21.5	
	Thickness	t 3	0.1	
Carry tape	Width	W 0	24.0	
	Thickness	t 1	0.4	
Overall thickness	t 2	4.2	Synthesis of cover tape and carry tape	

※ Material : Polystyrene

APPD.	CHK.	DESIGN	TRACE	OKAYA ELECTRIC INDUSTRIES CO.,LTD.

DATE OF ISSUE	SPECIFICATIONS	SPEC. -CD1076
		7/

(5) Shape and reference dimension of reel

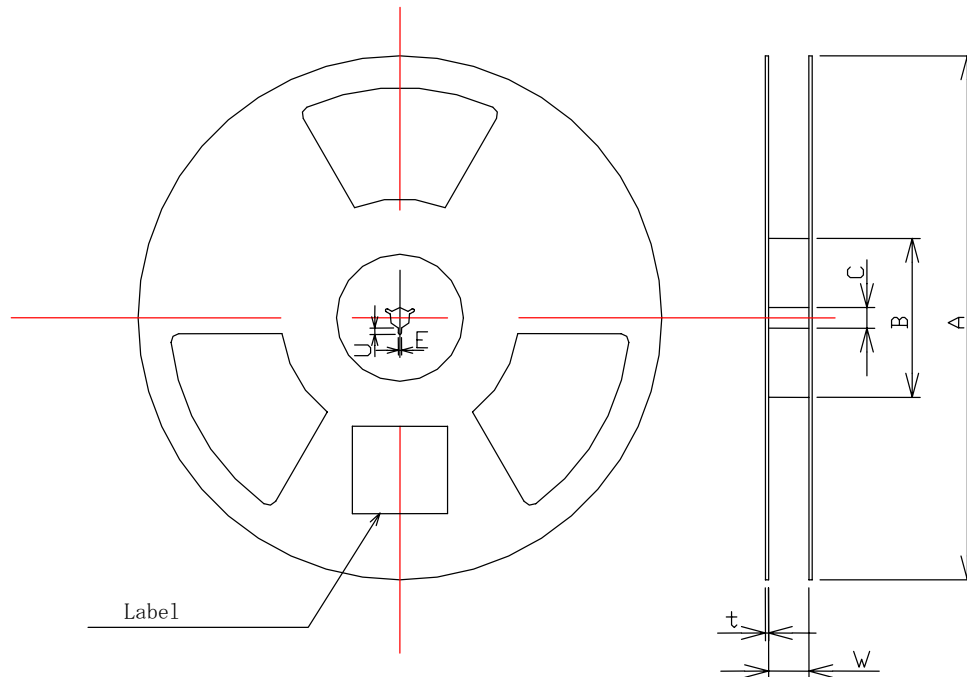

Item		Symbol	Reference dimension (mm)	Remarks	
Flange	diameter	A	ϕ 330		
	Thickness	t	2.0		
	Inner interval of both flanges	W	25.5	The size is to be the axial central part	
Hub	Perimeter diameter	B	ϕ 100		
	Diameter of spindle hole	C	ϕ 13		
	Key slot	Width	E	2.0	
		Depth	U	4.0	
Indication of product name		A label which indicated items, quantity, and the lot on single side of a flange is to be attached			

※ Material : Polystyrene

APPD.	CHK.	DESIGN	TRACE	OKAYA ELECTRIC INDUSTRIES CO.,LTD.

DATE OF ISSUE	SPECIFICATIONS	SPEC. -CD1076
		8/F

1 0 . PRECAUTIONS OF USE

(1) Reflow temperature

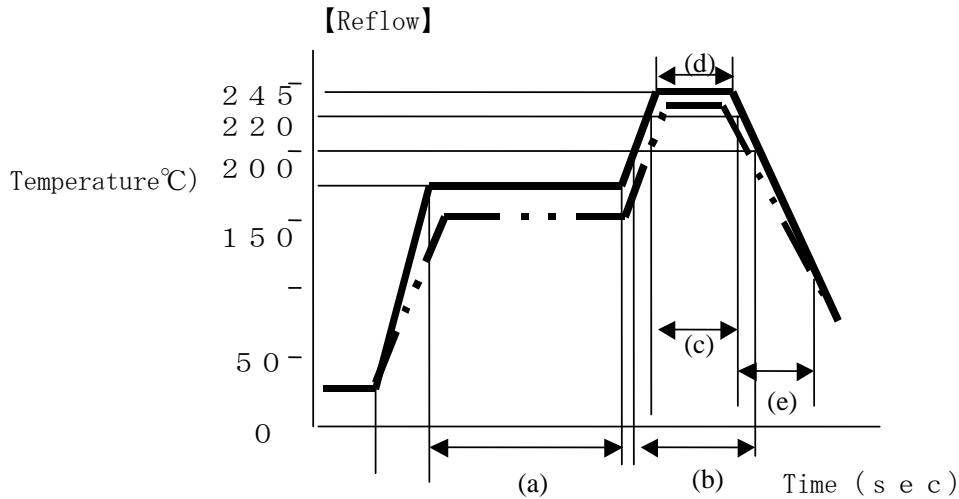

(a)	Preliminary heating	150°C~180°C 60sec~120sc
(b)	Actual heating	200°C 40sec~60sec
(c)		220°C 30sec~40sec
(d)	Peak temperature	245°C 5sec
(e)	Cooling	Compulsive air cooling

※ Please carry out reflow solder for 1 time only.

Please be careful of the following points of use.

- (2) Please avoid washing of the LED display unit.
- (3) Use a soft cloth with dilute alcohol when wiping off the spot attached to the LED surface and flux removal. Please wipe lightly.
- (4) Strong press should not be added against the segment of the LED display unit or DP surface part. It sometimes becomes the cause of reducing reliability.
- (5) A mechanical stress should not be added against the LED display unit at the time of soldering.
- (6) The epoxy resin is formed in the surface of a LED display unit. Keep in mind that it may be damaged if a tiptoe and a sharp thing are caught in the angle of a display unit.
- (7) The specification and appearance of this product may be changed for improvement upon mutual discussion in between both parties.

APPD.	CHK.	DESIGN	TRACE	OKAYA ELECTRIC INDUSTRIES CO.,LTD.