

PFM Step-Up DC/DC Converter

RCR2562

■ Features

- Low Start-up Voltage, 1.1V at 1mA
- Minimal Number of External Components (Only an Inductor, a Diode, a MOSFET and two Capacitors)
- Adjustable version ($V_{REF} = 1.25V$ $V_{REF} = 2.7V$ or $V_{REF} = 3.3V$)
- Ultra Low Input Current ($12\mu A$ at Switch Off)
- $\pm 2\%$ High Output Voltage Accuracy
- Low Ripple and Low Noise
- 75% Efficiency with Low Cost Inductor

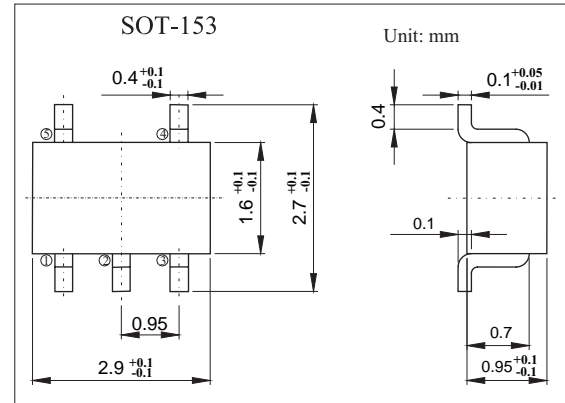

■ Functional Block Diagram

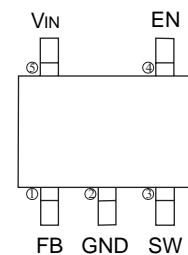
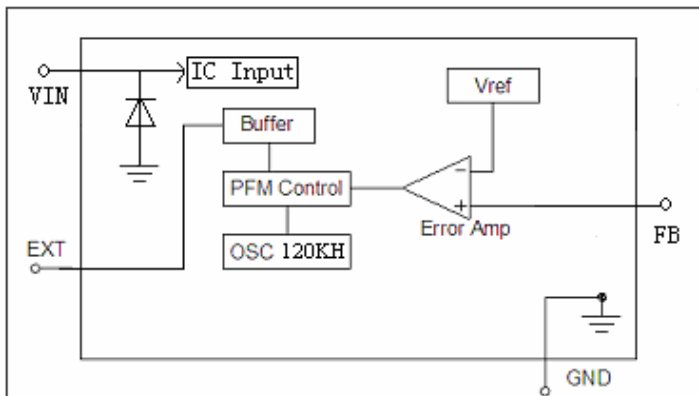

■ Absolute Maximum Ratings $T_a = 25^\circ C$

Parameter	Symbol	Rating	Unit
Output Voltage	V_{OUT}	-0.3 to +10	V
EXT Pin Voltage	V_{EXT}	-0.3 to +10	V
EXT Pin Current	I_{EXT}	± 30	mA
Power Dissipation @ $T_A = 25^\circ C$	P_D	250	mW
Operating Temperature Range	T_{OPR}	-40 to +150	$^\circ C$
Storage Temperature Range	T_{stg}	-65 to +150	$^\circ C$

RCR2562

■ Electrical Characteristics (Ta = 25°C, unless otherwise specified)

Parameter	Symbol	Test conditons	Min	Typ	Max	Unit
Output Voltage Accuracy	ΔV_{OUT}		-2		+2	%
Input Voltage	V_{IN}				10	V
FB Pin Voltage	V_{FB}	RCR2562 - 125SK	1.22	1.25	1.28	V
		RCR2562 - 270SK	2.65	2.70	2.75	V
		RCR2562 - 330SK	3.24	3.30	3.36	V
Start-up Voltage	V_{ST}	$I_{OUT} = 1mA, V_{IN} : 0 \text{ to } 2V$		1.0	1.1	V
Efficiency	E_{EFF}	$V_{OUT} \leq 3.5V$		75		%
		$V_{OUT} > 3.5V$		85		
Input Current1	I_{SS}	$V_{OUT} \leq 3.5V$ $V_{OUT} > 3.5V$	To be measured at V_{IN} at no load	30	40	μA
				50	60	
Input Current2	$I_{SWITCHING}$	$V_{OUT} \leq 3.5V$ $V_{OUT} > 3.5V$	To be measured at V_{OUT} in switch off condition	6	12	μA
Input Current1	I_{SS}	$V_{OUT} \leq 3.5V$ $V_{OUT} > 3.5V$	To be measured at V_{IN} at no load	30	40	μA
				50	60	
EXT"H"Output Current	I_{SH}	$V_{OUT} \leq 3.5V$ $V_{OUT} > 3.5V$	$V_{EXT} = V_{OUT} - 0.4V$	-1.5		mA
				-2		
EXT"L"Output Current	I_{SL}	$V_{OUT} \leq 3.5V$ $V_{OUT} > 3.5V$	$V_{EXT} = 0.4V$	1.5		mA
				2		
Maximum Oscillator	F_{MAX}		80	120	160	KHz
Oscillator Duty Cycle	D_{OSC}	On (VLx "L") side	70	78	85	%

■ Marking

Marking	RCR2562
---------	---------

■ Typical Application Circuit ($V_{OUT} = 5V$)

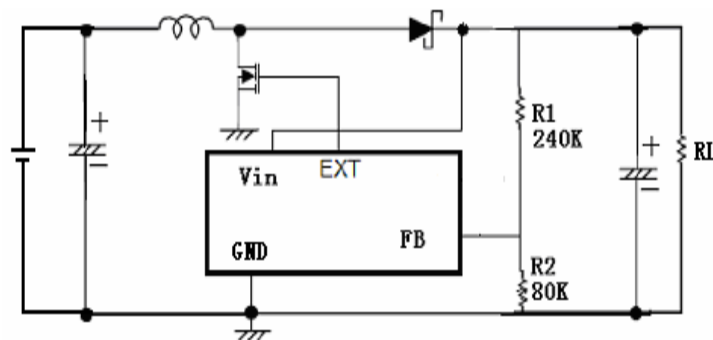

Components :

Inductor : 47uH,

Diode : 1N5818,

Input Capacitor : 1uF/10V (Tantalum)

Output Capacitor : 47uF/16V (Tantalum)

RCR2562

■ Typical Application Circuit

1、 RCR2562 (When $V_{OUT} = 5V$) :

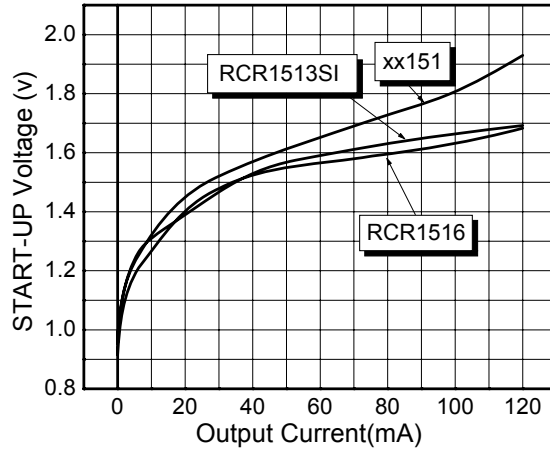

Figure1. Start-up Voltage VS Output Current

2、 RCR2562-125、 RCR2562-27 ($V_{OUT} = 3.0V$) :

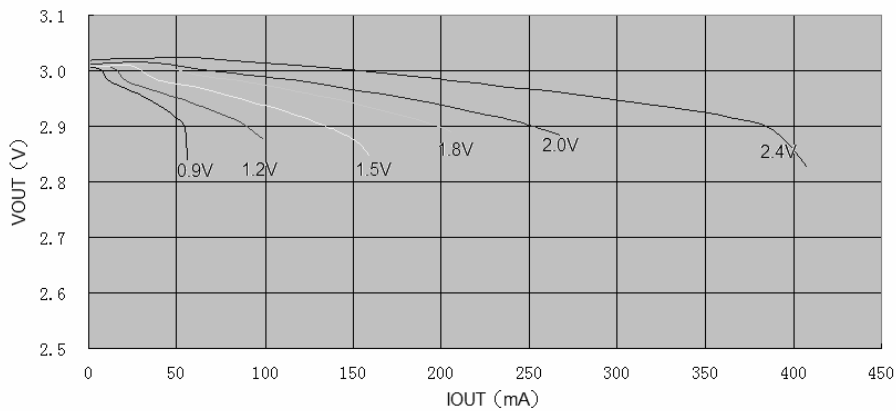

Figure2. Output Voltage VS Output Current

3、 RCR2562 ($V_{OUT} = 3.3V$) :

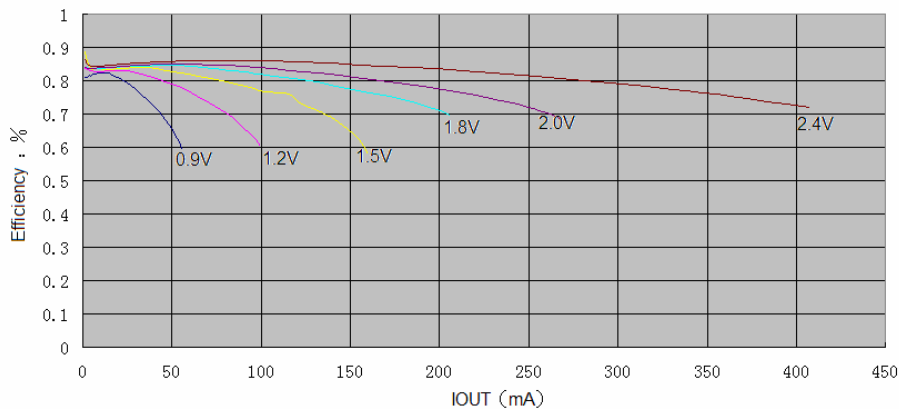

Figure3. Efficiency VS Output current

RCR2562

■ Typical Application Circuit

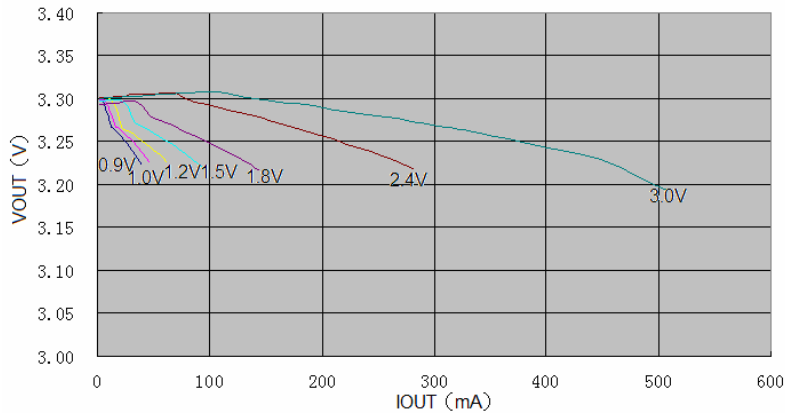

Figure4. Output Voltage VS Output current

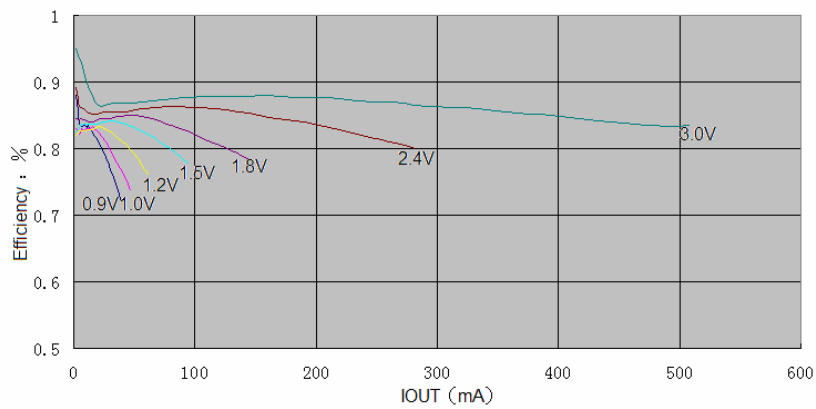

Figure5. Efficiency VS Output current

4、RCR2562 ($V_{OUT} = 5.0V$) :

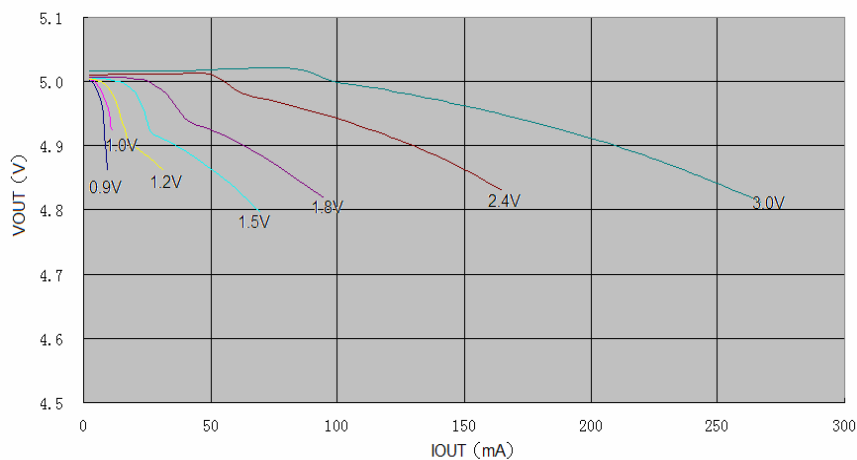

Figure6. Output Voltage VS Output current

RCR2562

■ Typical Application Circuit

5、Efficiency VS. Output Current:

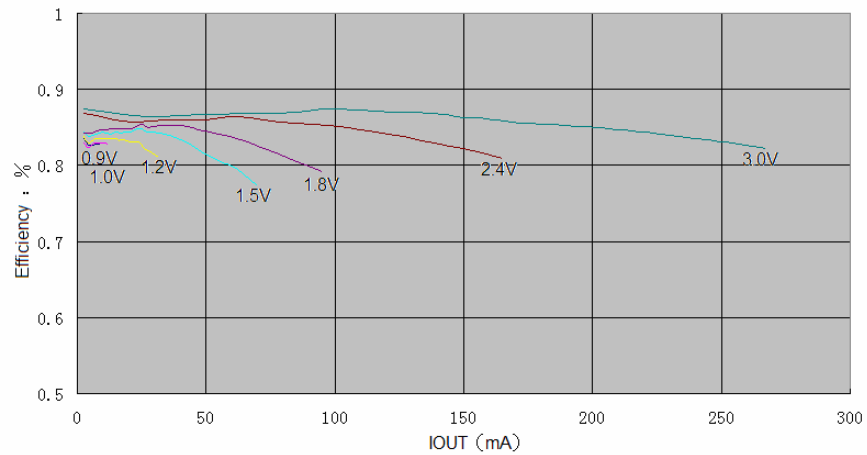

Figure7. Efficiency VS Output current