



RCR5

Preliminary

CMOS IC

REMOTE CONTROLLER WITH NINE FUNCTIONS

DESCRIPTION

The UTC **RCR5** is a CMOS LSI and designed as receiver that complement to UTC **RCT5** for remote controlled car applications. It provide nine control keys controlling the motions, which are forward, backward, rightward, leftward, four function keys, and the turbo function, of the remote controlled car.

UTC **RCR5** have Forward (Backward) combined with the turbo application. During normal operation without Turbo, Forward (Backward) output from UTC **RCR5** sends a 60Hz signal. When Forward (Backward) and Turbo are both in effect, the output signal becomes completely high.

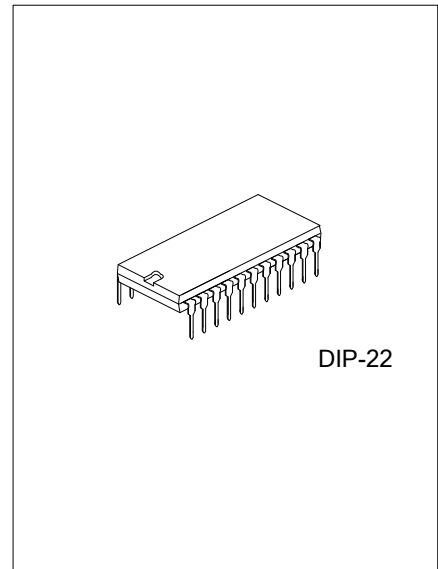

FEATURES

- * Operating voltage range: 2.4V~4.0V
- * Built-in 4.2V zener
- * Few external components needed
- * 9-function remote controller controlling Forward/ Backward/ Turbo/ Right-turn/ Left turn/ four function keys
- * Complement to UTC **RCT5**.

ORDERING INFORMATION

Ordering Number		Package	Packing
Lead Free	Halogen Free		
RCR5L-D22-T	RCR5G-D22-T	DIP-22	Tube

<p>RCR5L-D22-T</p> <p>(1) Packing Type</p> <p>(2) Package Type</p> <p>(3) Lead Free</p>	<p>(1) T: Tube</p> <p>(2) D22: DIP-22</p> <p>(5) L: Lead Free, G: Halogen Free</p>
---	--

MARKING

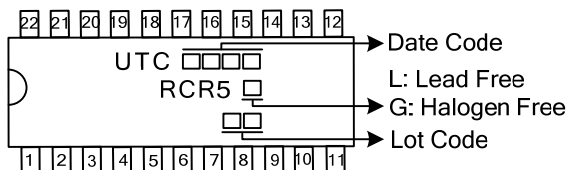

■ PIN CONFIGURATIONS

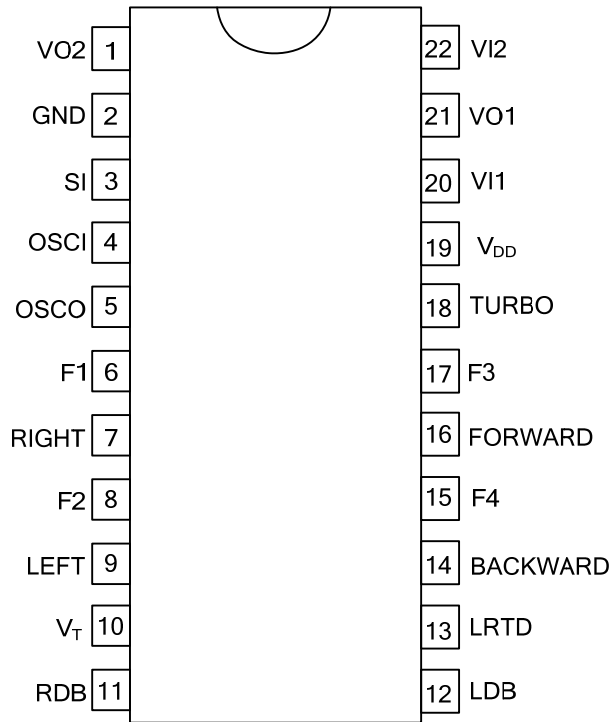

■ PIN DESCRIPTION

PIN NO.	PIN NAME	DESCRIPTION
1	VO2	Inverter 2 output pin for signal amplify
2	GND	Ground
3	SI	Input pin of the encoding signal
4	OSCI	Oscillator input pin
5	OSCO	Oscillator output pin
6	F1	F1 function output pin
7	RIGHT	Rightward output pin
8	F2	F2 function output pin
9	LEFT	Leftward output pin
10	V _T	Auto Shut-OFF input pin. If V _T voltage exceeds 1.4V, all outputs shut off automatically.
11	RDB	Right disable pin.
12	LDB	Left disable pin.
13	LRTD	Left/right turbo disable pin
14	BACKWARD	Backward output pin
15	F4	F4 function output pin
16	FORWARD	Forward output pin
17	F3	F3 function output pin
18	TURBO	TURBO output pin
19	V _{DD}	Power supply
20	VI1	Inverter 1 input pin for signal amplify
21	VO1	Inverter 1 output pin for signal amplify
22	VI2	Inverter 2 input pin for signal amplify

■ BLOCK DIAGRAM

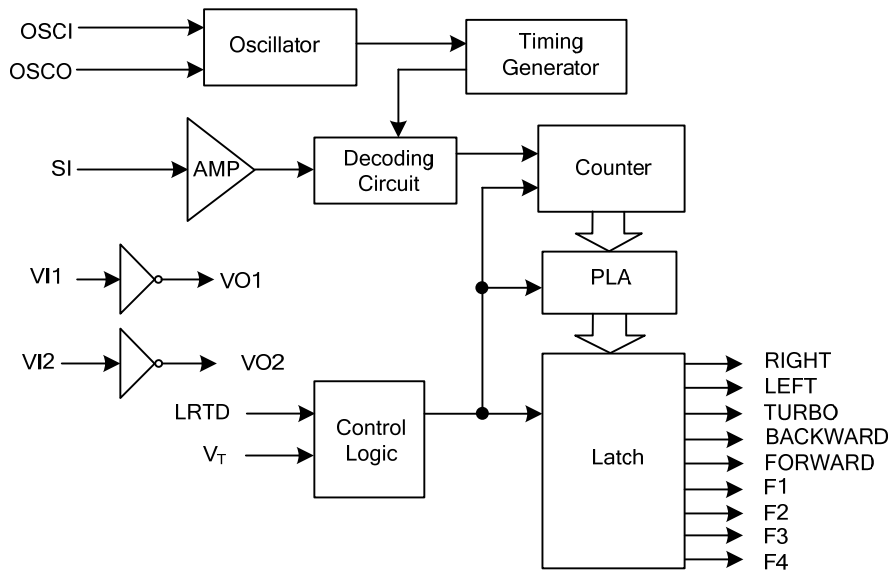

Input Condition	O/P Condition		
	Forward	Backward	Turbo
Forward	=60Hz	Low	Low
Backward	Low	=60Hz	Low
Forward + turbo	=high	Low	=high
Backward + turbo	Low	=high	=high

An Auto Shut-Off mechanism is built-in according to Toy Safety Requirement and effective during over-current situation in motor driver. The active high input applying to this Auto Shut-Off pin will turn off the motor. (V_T pin, when unused, has to be connected to ground. The transfer point =1.4V)

■ ABSOLUTE MAXIMUM RATINGS

PARAMETER	SYMBOL	RATINGS	UNIT
DC Supply Voltage	V_{DD}	2.4~4.0	V
Input/Output Voltage		GND-0.2~ $V_{DD}+0.2$	V
Operating Temperature	T_{OPR}	-10~+60	°C
Storage Temperature	T_{STG}	-25~+125	°C

Note: Absolute maximum ratings are those values beyond which the device could be permanently damaged. Absolute maximum ratings are stress ratings only and functional device operation is not implied.

■ ELECTRICAL CHARACTERISTICS ($T_A=25^{\circ}\text{C}$, $V_{DD}=3.0\text{V}$, $F_{osc}=128\text{KHz}$, unless otherwise specified.)

Direct Driving: No connect a resistance between POWER and IC's V_{DD} pin.

PARAMETER	SYMBOL	TEST CONDITIONS	MIN	TYP	MAX	UNIT
Operating Voltage	V_{OPR}		2.4	3.0	4.0	V
Operating Current	I_{OPR}	Unload	0.2	0.4	1.0	mA
O/P Driving Current	I_{DRIVE}	$V_{OH}=0.7\text{V}$	5.0			mA
O/P Driving Current (F1, F2)	I_{DRIVE}	$V_{OH}=0.7\text{V}$	5.0			mA
Effect Decoding (Frequency Variation)	$F_{TOLERANCE}$		-50		50	%
Oscillator Frequency	F_{OSC}			128		KHz
Oscillator Frequency Tolerance	Ftolerance	UTC RCT5 FOSC=128KHz	-20		+20	%

■ DATA FORMAT

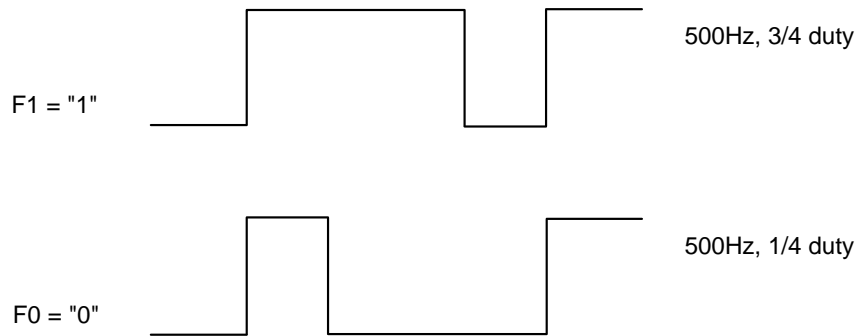

■ CODING METHOD

The data string that UTC RCR5 receiver is below:

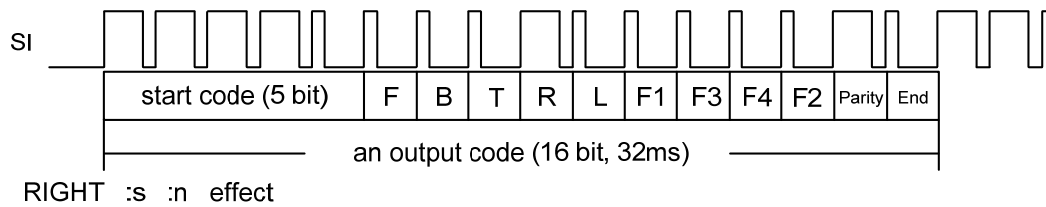

Data string: start code + data code + parity code + end code

- start code = F1 F1 F1 F1 F0

- data code =

F	B	T	R	L	F1	F3	F4	F2
---	---	---	---	---	----	----	----	----

F = Forward B = Backward T = Turbo
 R = Right L = Left F1 = Function 1
 F2 = Function 2 F3 = Function 3 F4 = Function 3

F、B、T、R、L、F1、F3、F4、F2 all can have two data format, "F1" or "F0",
 "F1" means the function is in effect, and "F0" means not.

- parity code = for parity check

- end code = for (latch data)

* Data code can be any combination of F, B, T, R, L, F1, F2, F3, F4 except for F & B, and R & L

■ OUTPUT TABLES

FUNCTION	OUTPUT STATUS								
	F	B	T	R	L	F1	F2	F3	F4
FORWARD	H								
LEFT + FORWARD	H				H				
RIGHT + FORWARD	H			H					
TURBO			H						
TURBO + FORWARD	H		H						
TURBO + LEFT + FORWARD	H		H		H				
TURBO + RIGHT + FORWARD	H		H	H					
BACKWARD		H							
BACKWARD + RIGHT		H		H					
BACKWARD + LEFT		H			H				
TURBO + BACKWARD		H	H						
TURBO + BACKWARD + RIGHT		H	H	H					
TRUBO + BACKWARD + LEFT		H	H		H				
LEFT					H				
RIGHT				H					
FUNCTION1						H			
FORWARD + FUNCTION1	H					H			
FORWARD + TURBO + FUNCTION1	H		H			H			
TURBO + FUNCTION1			H			H			
BACKWARD + FUNCTION1		H				H			
BACKWARD + TURBO + FUNCTION1		H	H			H			
LEFT + FORWARD + FUNCTION1	H				H	H			
RIGHT + FORWARD + FUNCTION1	H			H		H			
LEFT + BACKWARD + FUNCTION1		H			H	H			
RIGHT + BACKWARD + FUNCTION1		H		H		H			
LEFT + FUNCTION1					H	H			
RIGHT + FUNCTION1				H		H			
FUNCTION2							H		
FORWARD + FUNCTION2	H						H		
FORWARD + TURBO + FUNCTION2	H		H				H		
TURBO+ FUNCTION2			H				H		
BACKWARD + FUNCTION2		H					H		
BACKWARD + TURBO + FUNCTION2		H	H				H		
LEFT + FORWARD + FUNCTION2	H				H		H		
RIGHT + FORWARD + FUNCTION2	H			H			H		
LEFT + BACKWARD + FUNCTION2		H			H		H		
RIGHT + BACKWARD + FUNCTION2		H		H			H		
LEFT + FUNCTION2					H		H		
RIGHT + FUNCTION2				H			H		
FUNCTION3								H	
FORWARD + FUNCTION3	H							H	
FORWARD + TURBO + FUNCTION3	H		H					H	
TURBO+ FUNCTION3			H					H	
BACKWARD + FUNCTION3		H						H	
BACKWARD + TURBO + FUNCTION3		H	H					H	
LEFT + FORWARD + FUNCTION3	H				H			H	
RIGHT + FORWARD + FUNCTION3	H			H				H	
LEFT + BACKWARD + FUNCTION3		H			H			H	
RIGHT + BACKWARD + FUNCTION3		H		H				H	

■ OUTPUT TABLES(Cont.)

FUNCTION	OUTPUT STATUS									
	F	B	T	R	L	F1	F2	F3	F4	
LEFT + FUNCTION3					H			H		
RIGHT + FUNCTION3				H				H		
FUNCTION4									H	
FORWARD + FUNCTION4	H								H	
FORWARD + TURBO + FUNCTION4	H		H						H	
TURBO+ FUNCTION4			H						H	
BACKWARD + FUNCTION4		H							H	
BACKWARD + TURBO + FUNCTION4		H	H						H	
LEFT + FORWARD + FUNCTION4	H				H				H	
RIGHT + FORWARD + FUNCTION4	H			H					H	
LEFT + BACKWARD + FUNCTION4		H			H				H	
RIGHT + BACKWARD + FUNCTION4		H		H					H	
LEFT + FUNCTION4					H				H	
RIGHT + FUNCTION4				H					H	

H = high level, Z = 60Hz flash, Blank=L

Thus, from the table, we can see that there are more than 50 states of function combinations from 7 control keys.

Notes: 1. LRTD pin functions as an option pin for LEFT/RIGHT turbo disable.

"LRTD"	Key selected	Output Function
HIGH (OPEN)	FORWARD + LEFT (RIGHT) + TURBO	FORWARD + LEFT (RIGHT) + TURBO
LOW	FORWARD + LEFT (RIGHT) + TURBO	FORWARD + LEFT (RIGHT)

2. The UTC **RCR5** have built in a zener diode, so you must add a resistance between POWER and IC's V_{DD} pin, like the R6 of UTC **RCR5** application circuit.

■ TYPICAL APPLICATION CIRCUIT (FOR REFERENCE ONLY)

Receiver (UTC **RCR5** $f_{osc} \cong 128KHz$)

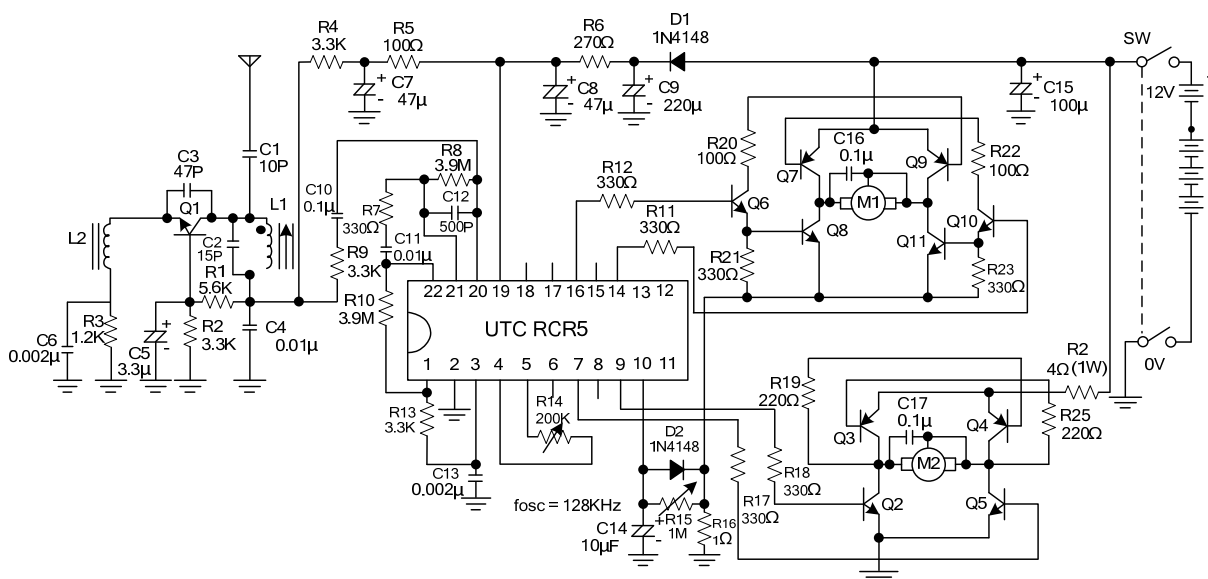

■ TEST CIRCUIT

Fosc for UTC RCR5 \cong 128KHz

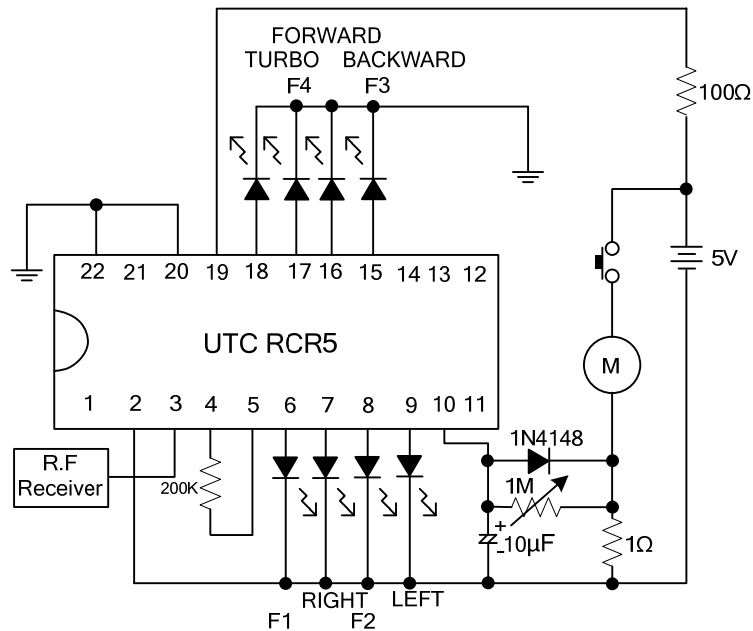

UTC RCT5 output pin (SO) has an inverted phase with UTC RCR5 input (SI). If UTC RCT5 is connected without using a R_F module, an inverter has to be inserted between this 2 pins.

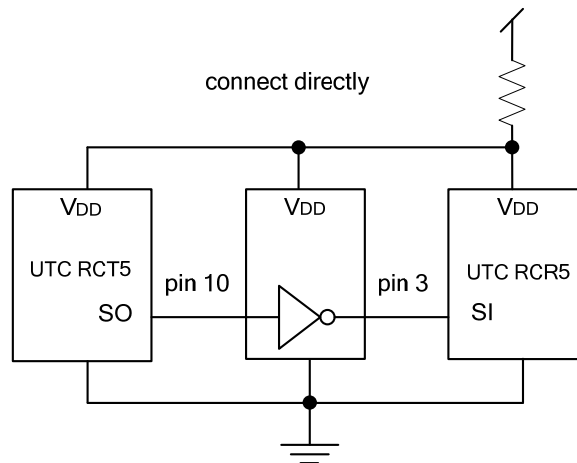

UTC assumes no responsibility for equipment failures that result from using products at values that exceed, even momentarily, rated values (such as maximum ratings, operating condition ranges, or other parameters) listed in products specifications of any and all UTC products described or contained herein. UTC products are not designed for use in life support appliances, devices or systems where malfunction of these products can be reasonably expected to result in personal injury. Reproduction in whole or in part is prohibited without the prior written consent of the copyright owner. The information presented in this document does not form part of any quotation or contract, is believed to be accurate and reliable and may be changed without notice.