



RCV1201D-52/155 FIBER OPTIC "LIGHT TO LOGIC"™ RECEIVER

Features:

- Light to Logic 28-pin DIP Receiver Offers ECL Compatibility
- High Sensitivity
 - 40.0 dBm at 52 Mbit/s
 - 36.0 dBm at 155 Mbits/s
- Wide temperature range -40 to +85°C
- Maximum Optical Input Power > -6dBm
- SONET/SDH Compliant

Applications:

- Telecommunications Networks
- SONET and SDH Compatible
- Local Area and Metropolitan Area Networks
- Military Communications and Control Systems
- Digital cable TV networks

RCV1201D-52/155

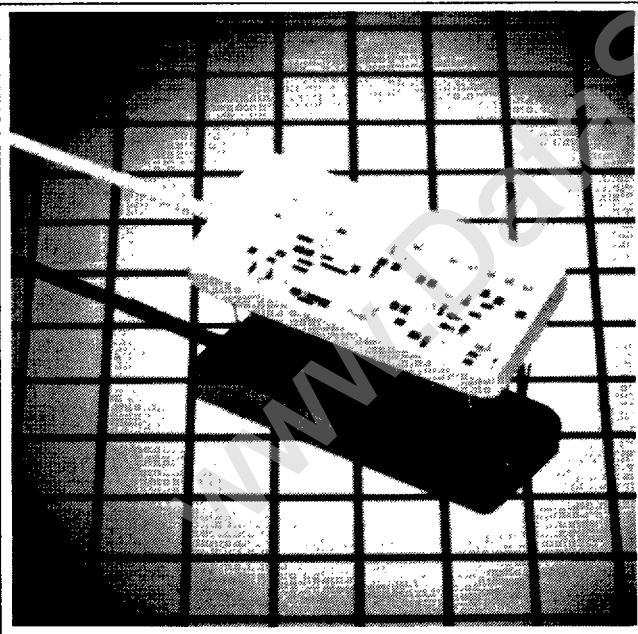

The RCV1201D receivers provide optical signal conversion and processing. They contain InGaAs PIN photodiodes and high sensitivity, wide dynamic range, transimpedance amplifier front ends. These are followed by limiting amplifier stages with ECL output drivers. Also provided are a TTL loss of signal alarm and an analogue data monitor output.

The highly sensitive pin photodiode operates throughout the 1250nm to 1600nm wavelength infrared band. A GaAs FET wide dynamic range transimpedance amplifier optimized for either 52Mbaud or 155Mbaud provides the necessary gain.

A low pass filter maximizes the signal to noise ratio while minimizing intersymbol interference. The interface amplifier provides signal conversion and buffering for the ECL 10K complementary data outputs and analogue eye monitor. A TTL open collector alarm output is also provided.

The receivers operate from +5 and -5.2V power supplies. A multimode fiber pigtail is included, assuring compatibility with multimode and singlemode fiber optic systems.

RCV1201D-052/155 CONNECTION DIAGRAM

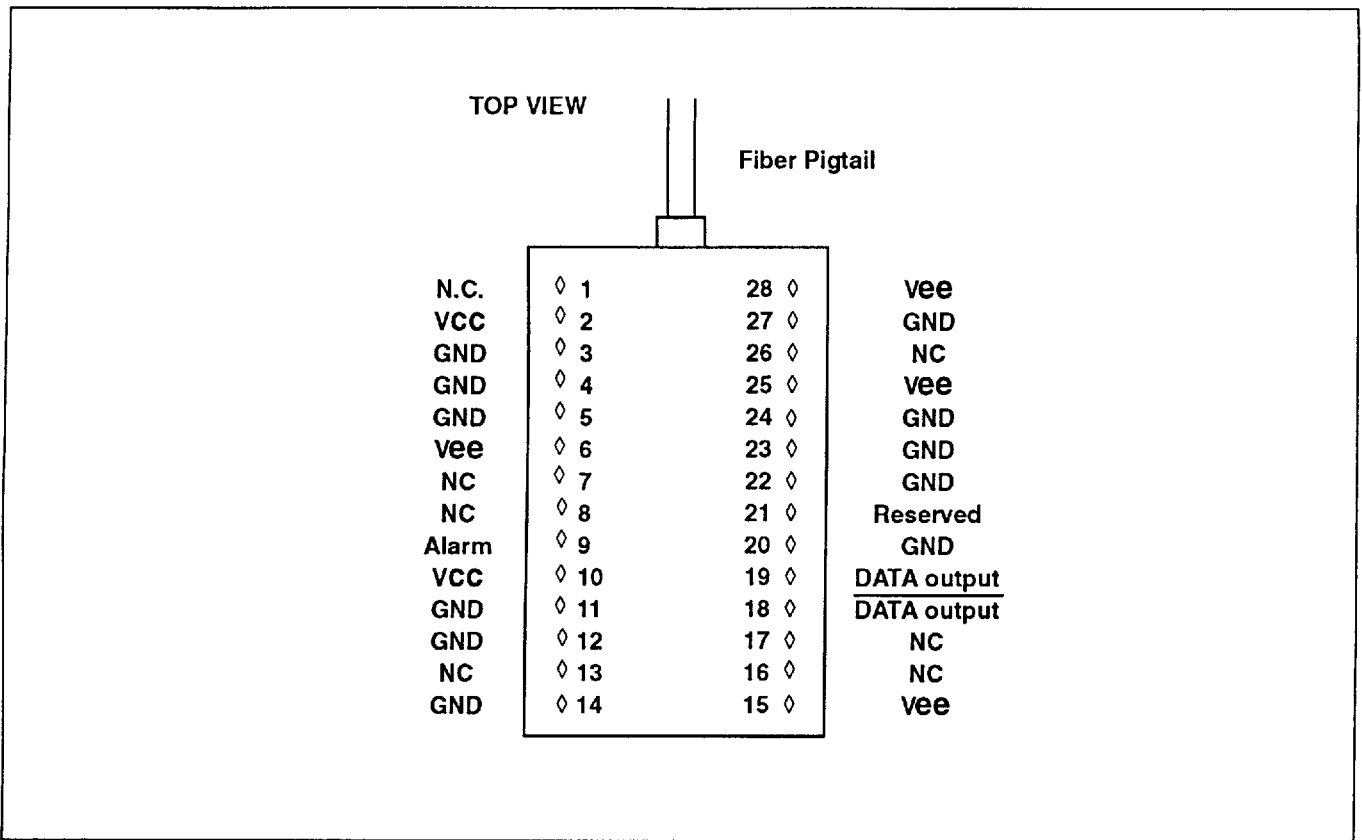

PIN DESCRIPTIONS

Vee (4 Pins):

These pins are connected to the -5 Volt supply. Pins 25 and 28 connect to the preamp (see Figure 1).

VCC (2 Pins):

These pins are connected to the +5 Volt supply. Pin 18 connects to a preamp and the alarm circuit, while pin 2 is the photodiode bias.

GND (11 Pins):

These pins are to be connected to the circuit board ground plane.

N.C. (7 Pins) :

These pins are not used in the present RCV1201D design. They should be left as an open circuit.

Reserved:

This pin is reserved for future product enhancements. It should be left as an open circuit.

DATA OUTPUT:

This pin is the inverted data output. It is at ECL Logic LOW during an input optical pulse. It must be terminated to a negative supply (See Page 4) for proper operation.

DATA OUTPUT:

This pin is the data output. It is at ECL Logic HIGH during an input optical pulse. It must be terminated to a negative supply. (See Page 4) for proper operation.

FUNCTIONAL DESCRIPTION RCV1201D-052/155

Design

The RCV1201D receivers contain a InGaAsP photodetector, transimpedance amplifier and interface amplifier circuit. They are designed with a 50/125 micron fiber pigtail to allow maximum flexibility in connector options.

The interface amplifier is capacitively coupled to the preamplifier circuit with a time constant of approximately 0.1ms.

Noise Immunity

The RCV1201D receivers have internal components to filter power supply noise from the gain circuits. To obtain maximum performance, it is highly recommended that external filter networks be used as well. The photodiode bias pin is especially sensitive to extraneous noise and a separate decoupling network is shown. The current drain on pin 2 is directly proportional to the incoming optical signal. This current will range from approximately 50nA on a small optical signal to 250µA on a large optical signal.

Additional external circuitry may be added to monitor the photodiode current for use as a simple signal detection circuit.

As a practical consideration, the majority of current drawn from the positive supply is used in the preamplifier. The interface amplifier draws the majority of the current from the negative supply.

Terminating the Outputs

The data outputs of the RCV1201D are 10KH ECL compatible. Figure 3 shows three options that are commonly used as terminations. While 50 ohm terminations are shown, other values can be used as well. Care should be taken to match termination impedances to the interconnect to minimize reflection effects. More information on ECL interconnection, biasing and termination can be found in most ECL manufacturer's data books.

Circuit Layout

The RCV1201D uses very high bandwidth circuitry to achieve its high level of performance. Care must be taken to ensure stable operation. The use of ground planes and transmission line interconnects is required. The use of a standard evaluation board is highly recommended for those users who are not familiar with these techniques. Evaluation boards for the RCV1201D are available from BT&D. Please contact your BT&D representative for details.

Manufacturing

The RCV1201D are fully hermetically sealed components. The fiber pigtail on the device requires normal fiber handling considerations. Care should be taken to avoid tight bends as well as excessive tension on the fiber pigtail.

The allowable temperature range for the RCV1201D is limited by the material used in the pigtail. Exposure to temperatures over 85°C is not recommended. Low profile sockets or hand soldering is recommended for this part.

Figure 1 - Block diagram of the RCV1201D

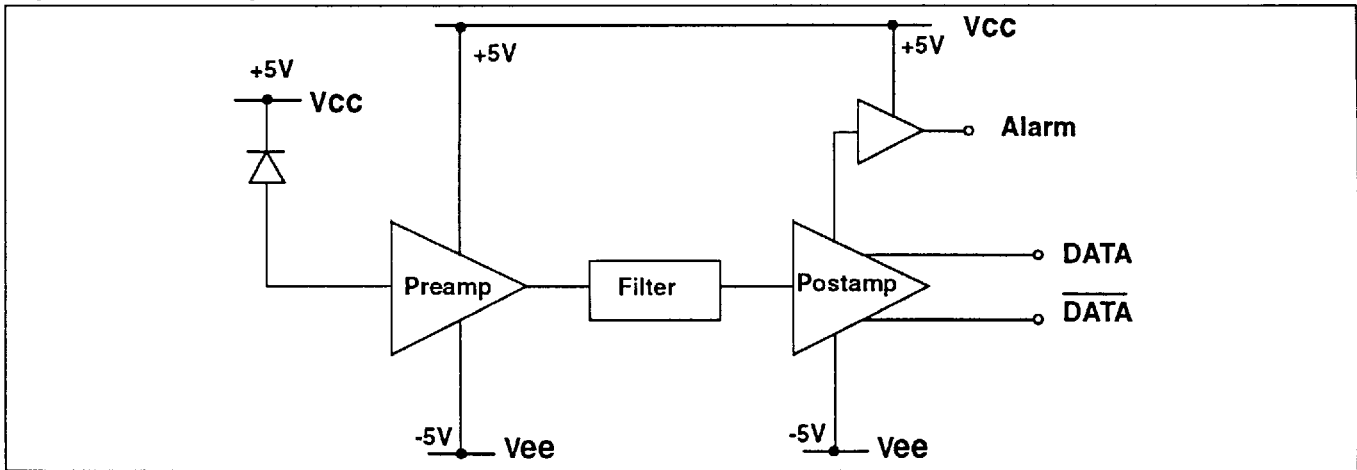

RCV1201D TERMINATION OPTIONS

Option 1 - (50 Ohms to -2 Volts)

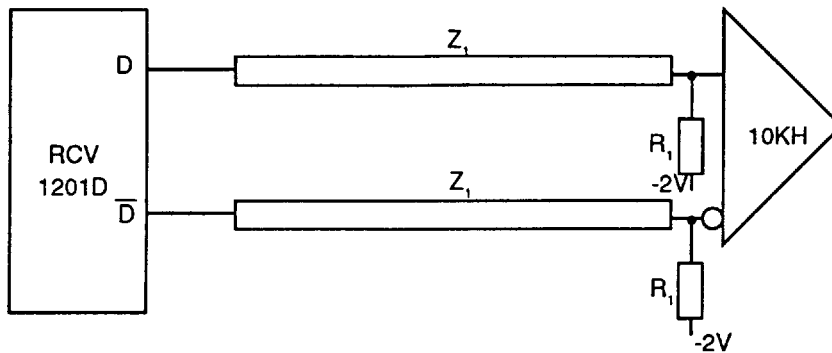

$Z_1 = 50$ Ohm Interconnect
$R_1 = 50$ Ohms

Figure 3A

Option 2 - Differential Termination

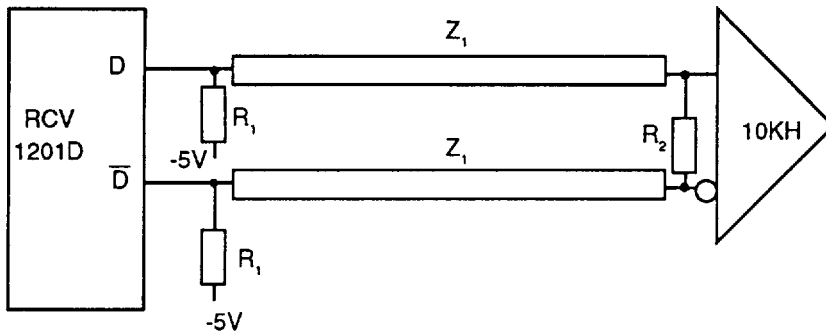

$Z_1 = 50$ Ohm Interconnect
$R_1 = 510$ Ohms
$R_2 = 100$ Ohms

Figure 3B

Option 3 P-ECL Operation (Capacitively Coupled)

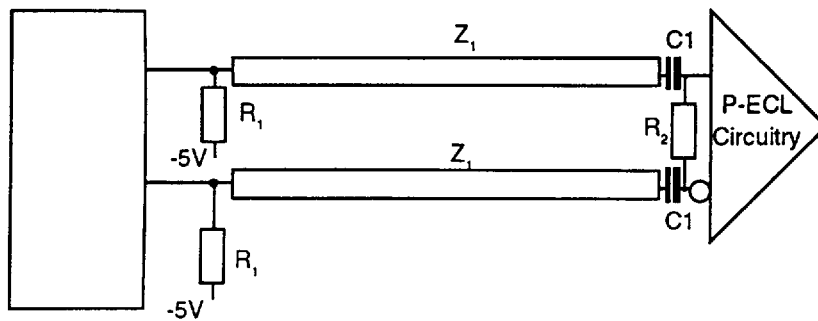

$C_1 = 100$ nF
$R_1 = 510$ Ohms
$R_2 = 100$ Ohms
$Z_1 = 50$ Ohm Intercon-

Figure 3C

RCV1201D ABSOLUTE LIMITING RATINGS

PARAMATER	SYMBOL	MIN	MAX	UNIT	NOTE
Supply voltage [1]	Vcc	-0.5	7.0	V	1
Supply voltage [1]	Vee	-7.0	0.5	V	1
Axial Fiber Pull	-	-	10	N	-
Fiber Bends Radius	-	-	32	mm	-
Soldering @ 350 °C	-	-	3	Sec	-
Weight (c/w Connector)	-	-	26	gms	-

ENVIRONMENTAL PARAMETERS

PARAMATER	SYMBOL	MIN	MAX	UNIT	NOTE
Operating Temperature	-	-40	+85	°C	-
Storage Temperature	-	-40	+85	°C	-
Hermeticity	-	-	1x10 ⁻⁶	Att/cc/Sec	-
Humidity (operating)	-	-	95	%	-
Humidity (storage)	-	-	95	%	-

ELECTRICAL PARAMETERS [4]

PARAMETER	SYMBOL	MIN	MAX	UNIT	NOTE
Supply Voltage	Vcc	4.75	5.25	V	-
Supply Voltage	Vee	-4.95	-5.46	V	-
VccSupply Current	-	-	50	mA	-
Vee Supply Current	-	-	110	mA	-
Power Dissipation	-	-	865	mW	-
Alarm Output Level OFF	V off	4	Vcc	V	-
Alarm Output Level ON	V on	0	0.4	V	-
Alarm Responses Time [2]	-	-	600	µs	2

OPTICAL PARAMETERS

PARAMETER	SYMBOL	MIN	MAX	UNIT	NOTE
Wavelength	-	1250	1600	nm	-
Receiver Sensitivity 52Mb	-	-	-40	dBm	3
155Mb	-	-	-36	dBm	3
Maximum I/P Power	-6.0	-	-	dBm	3
Alarm ON 52Mb	-	-48	-40	dBm	-
155MB	-	-44	-36	dBm	-
Hysteresis	-	0.5	3	dB	-
Reliability Target	-	-	2000	FIT	-

Notes

1. Vcc of -0.5V and Vee of +0.5V are not simultaneous requirements.
2. Time from removal of optical input signal to the time alarm output falls below 0.8V.
3. At a B.E.R. of 1X10⁻¹⁰, 2²³-1 pattern NRZ data at the line rate.
4. -40 °C TO 85 °C

RCV1201D PACKAGE DRAWING

DIM	MIN	NOM	MAX
A	42.90	-	43.20
B	19.50	-	19.80
C	5.90	-	6.60
D	5.10	-	-
E	-	0.44	-
F	-	25.0	25.0
G	400	-	1200
H	3.20	-	800
I	-	-	3.60
J	-	2.54	-
K	-	15.20	-
L	-	5.00	-
M	-	9.80	-
N	-	7.60	-
O	-	0.63	-

All dimensions in mm

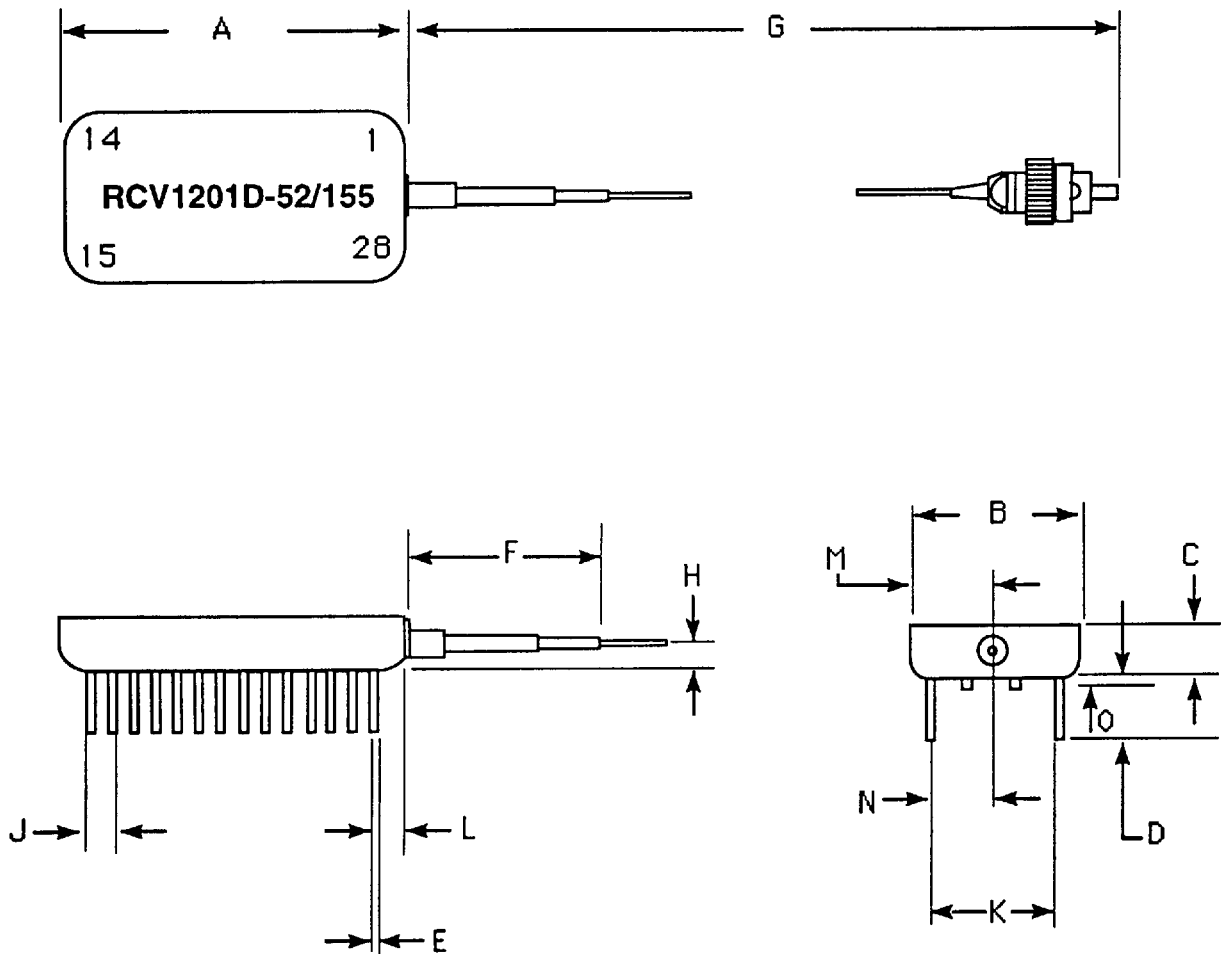

ORDERING INFORMATION

Please order part number - RCV1201D - 052 - FP

Allowable Part Numbers:

- RCV1201D-052-FP
- RCV1201D-155-FP
- RCV1201D-052-ST
- RCV1201D-155-ST

Connector:
FP = FC/PC Polish
ST = ST™

Specified Data Rate:
052= 52 Mbits/s
155= 155 Mbits/s

Model Name:
RCV1201D

HANDLING PRECAUTIONS

The RCV1201D can be damaged by current surges or overvoltage. Power supply transient precautions should be taken. Normal handling precautions for electrostatic sensitive devices should be taken.

Americas

BT&D Technologies
500 North Walnut Road
Kennett Square
PA 19348

Telephone:
(800) 545-4306 (U.S. only)
(215) 444-6888

Fax:
(215) 444-6868

Boston, MA
(617) 229-5805

San Jose, CA
(408) 428-9377
(800) 848-1923 (U.S. only)

Irvine, CA
(714) 453-8111

Dallas, TX
(214) 503-0085

Asia Pacific

BT&D Technologies
Du Pont Japan Technical Center
4997 Shin-Yoshida-Cho
Kohoku-Ku, Yokohama-Shi
Kanagawa 223, Japan

Telephone:
(045) 593-4870

Fax:
(045) 593-4852

Europe

BT&D Technologies, Ltd.
Whitehouse Road
Ipswich, Suffolk
IP1 5PB
England

Telephone:
0473-742250
Int: +44-473-742250

Fax:
+44-473-241110

ST is a registered trademark of AT&T

BT&D Technologies reserves the right to make changes to the products described herein without notice. No liability is assumed as a result of their use or application. No rights under any patent accompany the sale of any such product. All rights reserved. BT&D Technologies.
©BT&D 1992

