

RD151TS502US

PLL clock generator series

REJ03D0898-0100

Rev.1.00

Apr 25, 2007

Description

RD151TS502US is phase-locked loop clock generator with high-performance. And RD151TS502US is low-jitters and will enable high density mounting by shrink small-size package (SSOP-8).

Features

- Input frequency: 27.0 MHz
- Output frequency: 27.0 MHz (1 : 1), 33.75 MHz (1 : 1.25)
13.5 MHz (1 : 0.5), 16.875MHz (1 : 0.625) (Selectable)

Key Specifications

- Supply voltages: $V_{DD} = 2.7$ to 3.6 V
- Operating temperature = -10 to 75 °C
- Cycle to cycle jitter = ± 75 ps typ.
- Clock output duty cycle = $50 \pm 5\%$
- Stabilization time: 2ms max
- Power-down mode is supported
- Ordering Information

Part Name	Package Type	Package Code (Previous Package Code)	Package Abbreviation	Taping Abbreviation (Quantity)
RD151TS502USE	SSOP-8 pin	PVSP0008KA-A (TTP-8DBV)	US	E (3,000 pcs / Reel)

Pin Arrangement

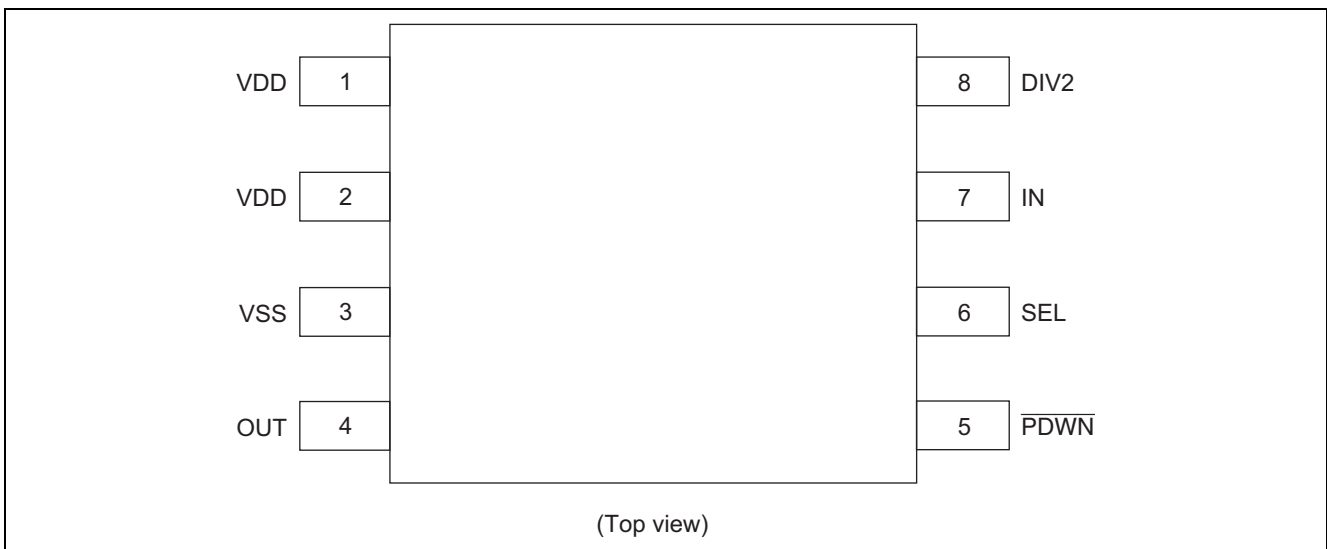

Block Diagram

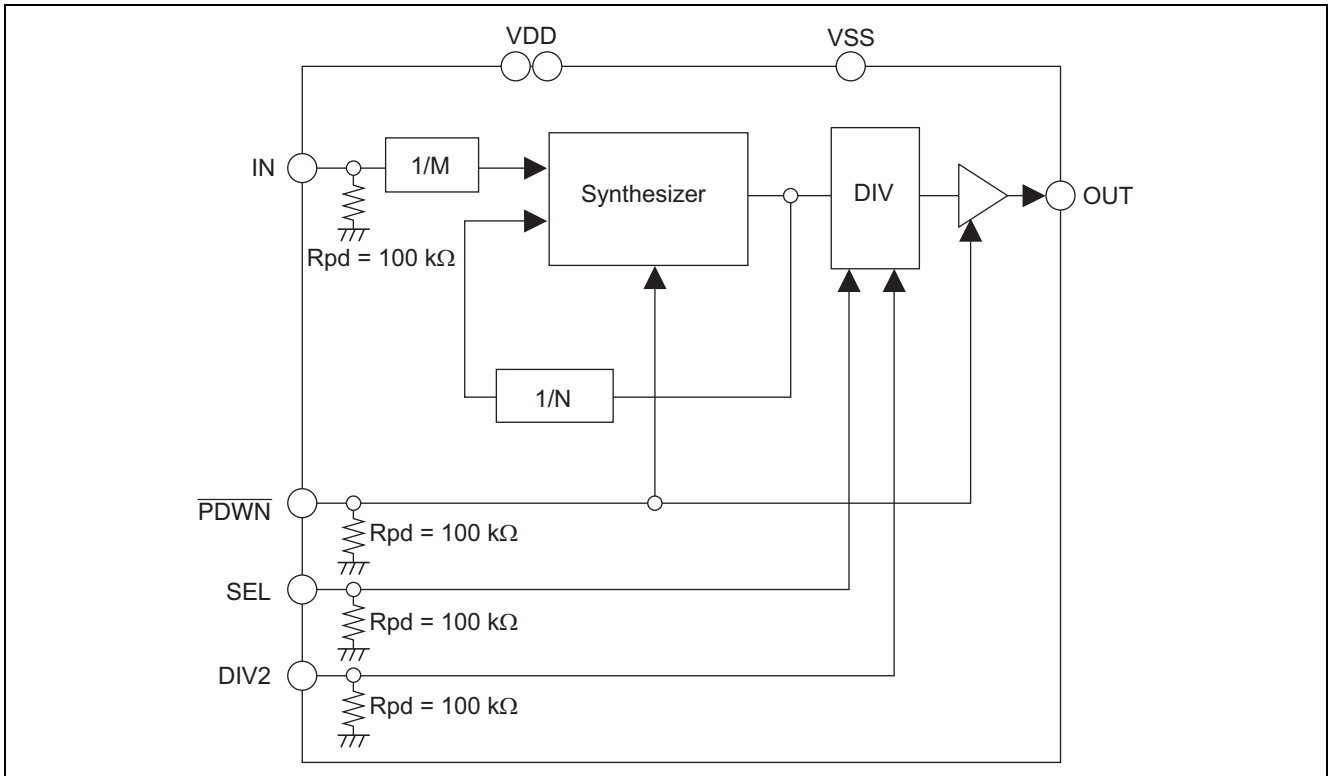

Pin Descriptions

Pin name	No.	Type	Description
VDD	1,2	Power	Power supply
VSS	3	Ground	GND
OUT	4	Output	Clock signal output
$\overline{\text{PDWN}}$	5	Input	Power-down control * ¹
SEL	6	Input	Frequency select * ¹
IN	7	Input	Clock signal input * ¹
DIV2	8	Input	Frequency select * ¹

Note: 1. LVCMOS level input. Pull-down by internal resistor (100 kΩ).

Power-down Function Table

$\overline{\text{PDWN}}$	IC Operating	OUTPUT	Remark
L	Power-down	Low level	Default * ¹
H	Active	Clock signal output	

Note: 1. All Circuits are set stand-by condition.

Clock Frequency Table

SEL	DIV2	Output Frequency (IN:OUT Ratio)	Remark
L	L	27.0 MHz (1:1)	Default
H	L	33.75 MHz (1:1.25)	
L	H	13.5 MHz (1:0.5)	
H	H	16.875 MHz (1:0.625)	

Absolute Maximum Ratings

Item	Symbol	Ratings	Unit	Conditions
Supply voltage	V_{DD}	-0.5 to 4.6	V	
Input voltage	V_I	-0.5 to 4.6	V	
Output voltage	V_O	-0.5 to $V_{DD}+0.5$	V	
Input clamp current *1	I_{IK}	-50	mA	$V_I < 0$
Output clamp current *1	I_{OK}	-50	mA	$V_O < 0$
Continuous output current	I_O	± 50	mA	$V_O = 0$ to V_{DD}
Maximum power dissipation	P_W	0.2	W	$T_a = 25^\circ\text{C}$ (in still air)
Storage temperature	T_{stg}	-65 to +150	$^\circ\text{C}$	

Notes: Stresses beyond those listed under "absolute maximum ratings" may cause permanent damage to the device. These are stress ratings only, and functional operation of the device at these or any other conditions beyond those indicated under "recommended operating conditions" is not implied.

- The input and output negative voltage ratings may be exceeded if the input and output clamp current ratings are observed.

Recommended Operating Conditions

Item	Symbol	Min	Typ	Max	Unit	Conditions
Supply voltage	V_{DD}	2.7	3.3	3.6	V	
DC input signal voltage		-0.3	—	$V_{DD}+0.3$	V	
Operating temperature	T_a	-10	—	75	$^\circ\text{C}$	

DC Electrical Characteristics

$T_a = -10$ to 75°C , $V_{DD} = 2.7$ to 3.6 V

Item	Symbol	Min	Typ	Max	Unit	Test Conditions
Input voltage	V_{IL}	—	—	0.8	V	IN, PDWN, SEL, DIV2 pins
	V_{IH}	2.0	—	—	V	IN, $\overline{\text{PDWN}}$, SEL, DIV2 pins
Input current	I_I	—	—	± 100	μA	$V_I = 0\text{V}$ or 3.6V , IN, $\overline{\text{PDWN}}$, SEL, DIV2 pins
Input capacitance	C_I	—	3	—	pF	IN, PDWN, SEL, DIV2 pins
Output voltage	V_{OL}	—	—	0.5	V	$V_{OL} = 1$ mA, $V_{DD} = 3.3$ V, OUT pin
	V_{OH}	$V_{DD}-0.2$	—	V_{DD}		$V_{OH} = -1$ mA, $V_{DD} = 3.3$ V, OUT pin
Output current	I_{OL}	—	15	—	mA	$V_{OL} = 1.65$ V, $V_{DD} = 3.3$ V, OUT pin
	I_{OH}	—	-15	—	mA	$V_{OH} = 1.65$ V, $V_{DD} = 3.3$ V, OUT pin
Output impedance		—	30	—	Ω	OUT pin
Pull-down resistor	R_{pd}	80 k	100 k	120 k	Ω	

Note: The condition of the minimum and maximum value must use the value specified under "Recommended Operating Conditions".

Parameters are target of design. Not 100% tested in production.

AC Electrical Characteristics

$T_a = -10$ to 75 °C, $V_{DD} = 2.7$ to 3.3 V, $C_L = 15$ pF

Item	Symbol	Min	Typ	Max	Unit	Test Conditions	Notes
Operating current	I_{DD}	—	6	—	mA	$V_{DD} = 3.3$ V, $\overline{PDWN} = 1$, $C_L = 0$ pF	
Stand-by current	I_{DDPD}	—	10	—	μA	$V_{DD} = 3.3$ V, $\overline{PDWN} = 0$, $I_N = 0$ V	
Cycle to cycle jitter	t_{CCJ}	—	75	—	ps	$C_L = 0$ pF	Figure 1
Output Frequency		—	13.5	—	MHz	SEL = 0, DIV2 = 1	*1 Figure 2
		—	16.875	—		SEL = 1, DIV2 = 1	
		—	27.0	—		SEL = 0, DIV2 = 0	
		—	33.75	—		SEL = 1, DIV2 = 0	
Frequency accuracy		-50	—	50	ppm		*2
Slew Rate	t_{SR}	—	1.5	—	ns	$V_{DD} = 3.3$ V, $0.2V_{DD}$ to $0.8V_{DD}$	
Clock duty cycle	t_{DT}	45	50	55	%		
Stabilization time	t_{SB}	—	—	2	ms		*3

Notes: Parameters are target of design. Not 100% tested in production.

1. Output Frequency means average value.
2. The accuracy of the output frequency to a set value.
3. Stabilization time is the time required for the integrated circuit to obtain phase lock of its input signal after power up.

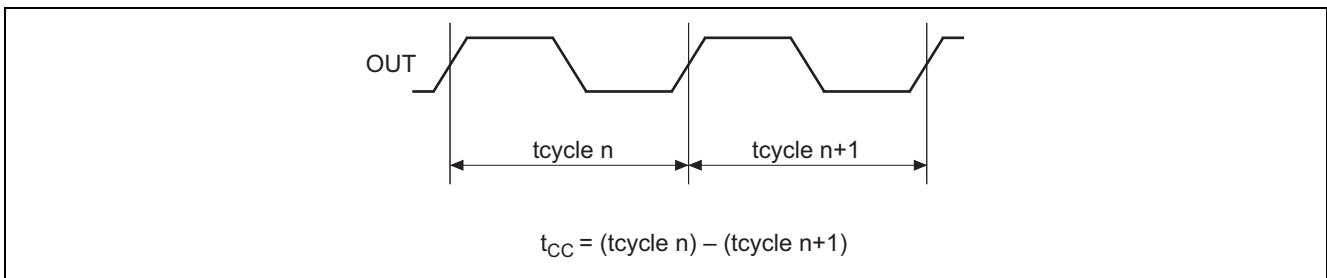

Figure 1 Cycle to cycle jitter

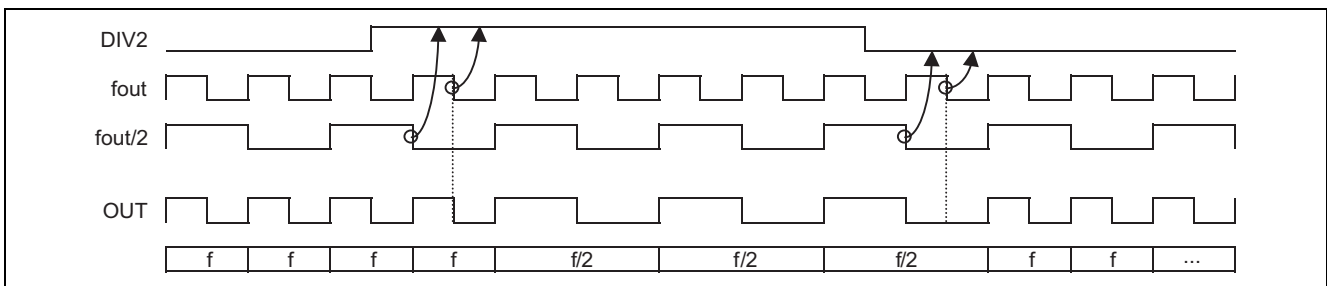

Figure 2 Timing chart

Recommended Circuit Configuration

The power supply circuit of the optimal performance on the application of a system should refer to Figure 3.

V_{DD} decoupling is important to reduce Jitter performance.

The C1 decoupling capacitor should be placed as close to the VDD pin as possible, otherwise the increased trace inductance will negate its decoupling capability.

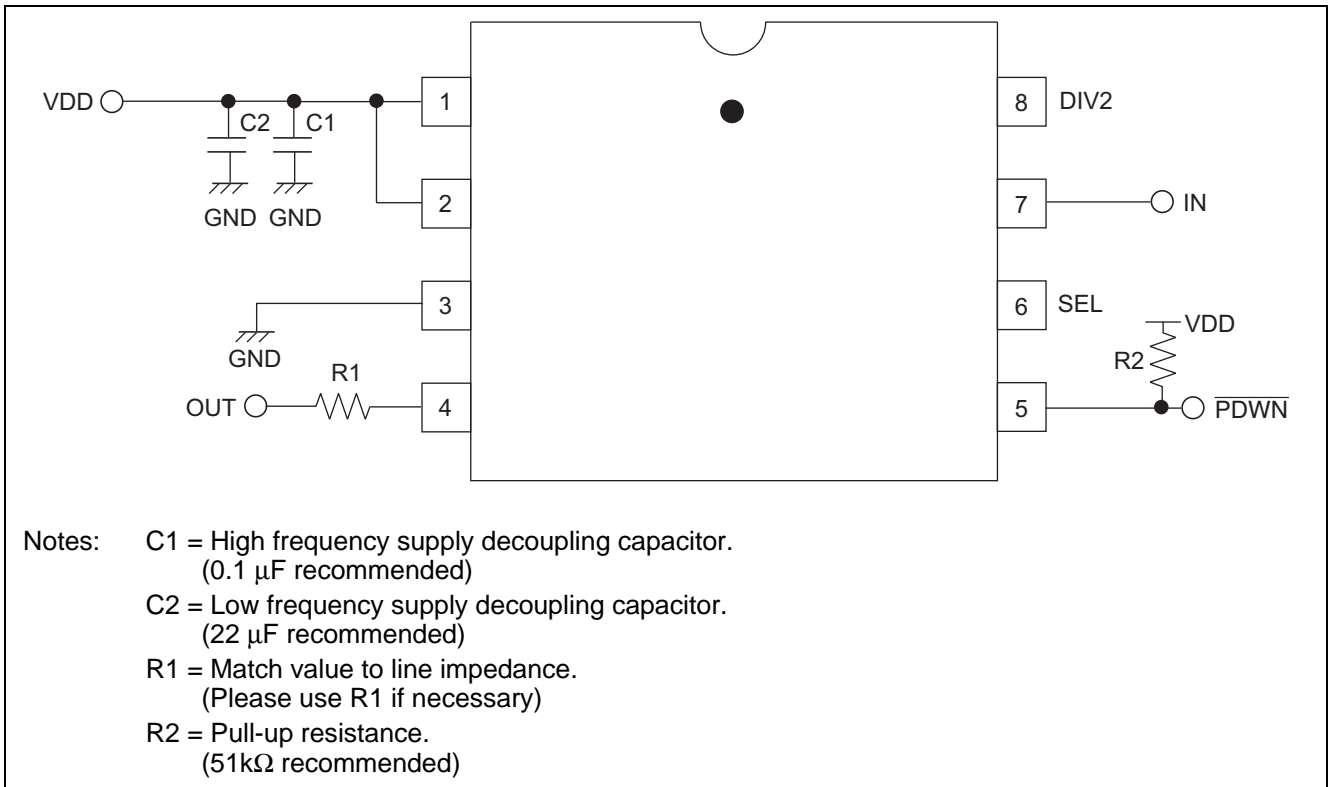

Figure 3 Recommended circuit configuration

Remark for use

- Please do not use the pull-up resistance for the OUT terminal to prevent wrong operation of IC.
- Please set the voltage of the PDWN terminal according to the following procedures when it is necessary to set IC to power-down (standby) operation immediately after the start-up this IC.
 1. Set the Hi level voltage when IC starts.
 2. Set the Low level voltage after IC starts.

As this counter measures, we recommend the pull-up register that has been described to the above recommended circuit to be added beforehand.

Package Dimensions

JEITA Package Code	RENESAS Code	Previous Code	MASS[Typ.]
P-VSSOP8-2.3x2-0.50	PVSP0008KA-A	TTP-8DB/TTP-8DBV	0.010g

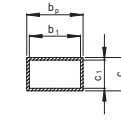
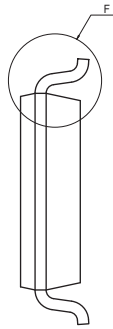
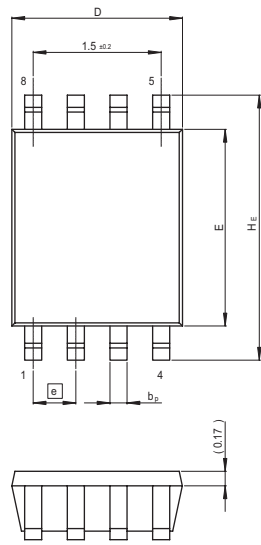

Terminal cross section

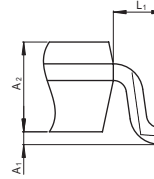

Detail F

Reference Symbol	Dimension in Millimeters		
	Min	Nom	Max
D	1.8	2.0	2.2
E	2.2	2.3	2.4
A ₂	0.6	0.7	0.8
A ₁	0	—	0.1
A	—	—	—
b _p	0.15	0.22	0.3
b ₁	—	0.20	—
c	0.08	0.13	0.23
c ₁	—	0.11	—
θ	—	—	—
H _E	2.8	3.1	3.4
ⓐ	—	(0.5)	—
x	—	—	—
y	—	—	—
Z	—	—	—
L	—	—	—
L ₁	—	(0.4)	—

Notes:

1. This document is provided for reference purposes only so that Renesas customers may select the appropriate Renesas products for their use. Renesas neither makes warranties or representations with respect to the accuracy or completeness of the information contained in this document nor grants any license to any intellectual property rights or any other rights of Renesas or any third party with respect to the information in this document.
2. Renesas shall have no liability for damages or infringement of any intellectual property or other rights arising out of the use of any information in this document, including, but not limited to, product data, diagrams, charts, programs, algorithms, and application circuit examples.
3. You should not use the products or the technology described in this document for the purpose of military applications such as the development of weapons of mass destruction or for the purpose of any other military use. When exporting the products or technology described herein, you should follow the applicable export control laws and regulations, and procedures required by such laws and regulations.
4. All information included in this document such as product data, diagrams, charts, programs, algorithms, and application circuit examples, is current as of the date this document is issued. Such information, however, is subject to change without any prior notice. Before purchasing or using any Renesas products listed in this document, please confirm the latest product information with a Renesas sales office. Also, please pay regular and careful attention to additional and different information to be disclosed by Renesas such as that disclosed through our website. (<http://www.renesas.com>)
5. Renesas has used reasonable care in compiling the information included in this document, but Renesas assumes no liability whatsoever for any damages incurred as a result of errors or omissions in the information included in this document.
6. When using or otherwise relying on the information in this document, you should evaluate the information in light of the total system before deciding about the applicability of such information to the intended application. Renesas makes no representations, warranties or guarantees regarding the suitability of its products for any particular application and specifically disclaims any liability arising out of the application and use of the information in this document or Renesas products.
7. With the exception of products specified by Renesas as suitable for automobile applications, Renesas products are not designed, manufactured or tested for applications or otherwise in systems the failure or malfunction of which may cause a direct threat to human life or create a risk of human injury or which require especially high quality and reliability such as safety systems, or equipment or systems for transportation and traffic, healthcare, combustion control, aerospace and aeronautics, nuclear power, or undersea communication transmission. If you are considering the use of our products for such purposes, please contact a Renesas sales office beforehand. Renesas shall have no liability for damages arising out of the uses set forth above.
8. Notwithstanding the preceding paragraph, you should not use Renesas products for the purposes listed below:
 - (1) artificial life support devices or systems
 - (2) surgical implantations
 - (3) healthcare intervention (e.g., excision, administration of medication, etc.)
 - (4) any other purposes that pose a direct threat to human lifeRenesas shall have no liability for damages arising out of the uses set forth in the above and purchasers who elect to use Renesas products in any of the foregoing applications shall indemnify and hold harmless Renesas Technology Corp., its affiliated companies and their officers, directors, and employees against any and all damages arising out of such applications.
9. You should use the products described herein within the range specified by Renesas, especially with respect to the maximum rating, operating supply voltage range, movement power voltage range, heat radiation characteristics, installation and other product characteristics. Renesas shall have no liability for malfunctions or damages arising out of the use of Renesas products beyond such specified ranges.
10. Although Renesas endeavors to improve the quality and reliability of its products, IC products have specific characteristics such as the occurrence of failure at a certain rate and malfunctions under certain use conditions. Please be sure to implement safety measures to guard against the possibility of physical injury, and injury or damage caused by fire in the event of the failure of a Renesas product, such as safety design for hardware and software including but not limited to redundancy, fire control and malfunction prevention, appropriate treatment for aging degradation or any other applicable measures. Among others, since the evaluation of microcomputer software alone is very difficult, please evaluate the safety of the final products or system manufactured by you.
11. In case Renesas products listed in this document are detached from the products to which the Renesas products are attached or affixed, the risk of accident such as swallowing by infants and small children is very high. You should implement safety measures so that Renesas products may not be easily detached from your products. Renesas shall have no liability for damages arising out of such detachment.
12. This document may not be reproduced or duplicated, in any form, in whole or in part, without prior written approval from Renesas.
13. Please contact a Renesas sales office if you have any questions regarding the information contained in this document, Renesas semiconductor products, or if you have any other inquiries.



RENESAS SALES OFFICES

<http://www.renesas.com>

Refer to "<http://www.renesas.com/en/network>" for the latest and detailed information.

Renesas Technology America, Inc.
450 Holger Way, San Jose, CA 95134-1368, U.S.A
Tel: <1> (408) 382-7500, Fax: <1> (408) 382-7501

Renesas Technology Europe Limited
Dukes Meadow, Millboard Road, Bourne End, Buckinghamshire, SL8 5FH, U.K.
Tel: <44> (1628) 585-100, Fax: <44> (1628) 585-900

Renesas Technology (Shanghai) Co., Ltd.
Unit 204, 205, AZIACenter, No.1233 Lujiazui Ring Rd, Pudong District, Shanghai, China 200120
Tel: <86> (21) 5877-1818, Fax: <86> (21) 6887-7898

Renesas Technology Hong Kong Ltd.
7th Floor, North Tower, World Finance Centre, Harbour City, 1 Canton Road, Tsimshatsui, Kowloon, Hong Kong
Tel: <852> 2265-6688, Fax: <852> 2730-6071

Renesas Technology Taiwan Co., Ltd.
10th Floor, No.99, Fushing North Road, Taipei, Taiwan
Tel: <886> (2) 2715-2888, Fax: <886> (2) 2713-2999

Renesas Technology Singapore Pte. Ltd.
1 Harbour Front Avenue, #06-10, Keppel Bay Tower, Singapore 098632
Tel: <65> 6213-0200, Fax: <65> 6278-8001

Renesas Technology Korea Co., Ltd.
Kukje Center Bldg. 18th Fl., 191, 2-ka, Hangang-ro, Yongsan-ku, Seoul 140-702, Korea
Tel: <82> (2) 796-3115, Fax: <82> (2) 796-2145

Renesas Technology Malaysia Sdn. Bhd
Unit 906, Block B, Menara Amcorp, Amcorp Trade Centre, No.18, Jalan Persiaran Barat, 46050 Petaling Jaya, Selangor Darul Ehsan, Malaysia
Tel: <603> 7955-9390, Fax: <603> 7955-9510