

lenovo

ThinkServer RD330
User Guide

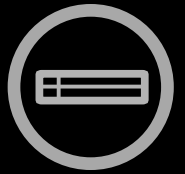

ThinkThink**ThinkServer**Think

Machine Types: 3072, 3073, 3074, 4302, 4304, and 4305

Note:

Before using the information and the product it supports, be sure to read and understand the following:

- The *Read Me First* that comes with your product
- “Safety information” on page iii
- Appendix A “Notices” on page 163

First Edition (August 2012)

© Copyright Lenovo 2012.

LIMITED AND RESTRICTED RIGHTS NOTICE: If data or software is delivered pursuant a General Services Administration “GSA” contract, use, reproduction, or disclosure is subject to restrictions set forth in Contract No. GS-35F-05925.

Contents

Safety information	iii	Setup Utility program interface	46
Chapter 1. General information	1	Setting the system date and time	48
Introduction	1	Using passwords	49
Server documentation	2	Selecting a startup device	50
Chapter 2. Server setup road map	5	Configuring the TPM function	50
Chapter 3. Product overview	7	Setting the mode of the Ethernet connector 0	51
Server package	7	Exiting the Setup Utility program	51
Features	7	Updating or recovering the BIOS	51
Specifications	11	Using the ThinkServer EasyStartup program	53
Software	11	Features of the ThinkServer EasyStartup program	53
ThinkServer EasyStartup	11	Starting the ThinkServer EasyStartup program	54
ThinkServer EasyUpdate Firmware Updater	12	Using the ThinkServer EasyStartup program on a Windows operating system	55
Lenovo ThinkServer EasyManage	12	Configuring RAID	56
BIOS and TMM update utilities	12	About RAID	56
RAID configuration utilities	12	Configuring RAID using the ThinkServer EasyStartup program	58
Remote management software	12	Configuring the ThinkServer RAID 300	58
Lenovo Rack Planner	12	Configuring the advanced SATA/SAS hardware RAID	63
ThinkServer Smart Grid Technology	12	Configuring the Ethernet controllers	64
Locations	13	Updating the firmware	64
Machine type, model, and serial number label	13	Using the Firmware Updater program	64
Front view of the server	14	Using the Lenovo ThinkServer EasyManage program	65
Front panel	17	Chapter 6. Installing, removing, or replacing hardware	67
Intelligent Diagnostics Module	19	Guidelines	67
Rear view of the server	20	Precautions	67
Server components	22	Handling static-sensitive devices	68
Hot-swap hard disk drive status LEDs	25	System reliability guidelines	69
RAID card	25	Working inside the server with the power on	69
Hot-swap hard disk drive backplane	27	Removing the server cover	69
Mini-SAS to mini-SAS signal cable connections	29	Installing, removing, or replacing hardware	71
System board components	31	Removing and reinstalling the rack handles	71
System board jumpers and switches	34	Removing and reinstalling the cooling shroud	73
System board LEDs	39	Installing or removing a memory module	75
Chapter 4. Turning on and turning off the server	43	Installing or removing the Ethernet card	81
Turning on the server	43	Installing or removing the RAID card	85
Turning off the server	43	Installing or removing the ThinkServer RAID 500 Upgrade Key for Advanced RAID	89
Chapter 5. Configuring the server	45	Installing or removing the ThinkServer RAID 700 Battery	93
Using the Setup Utility program	45		
Starting the Setup Utility program	45		
Viewing information in the Setup Utility program	45		

Installing or removing the ThinkServer RAID 300 Upgrade Key for Advanced RAID	96
Installing or removing the ThinkServer Management Module Premium	100
Installing or removing the ThinkServer Trusted Platform Module	103
Installing or replacing a hot-swap redundant power supply	106
Installing or replacing a heat sink.	110
Installing or replacing the microprocessor	113
Installing or replacing a hot-swap hard disk drive	122
Installing or replacing the optical drive	126
Replacing the hot-swap hard disk drive backplane.	132
Replacing the Intelligent Diagnostics Module.	137
Replacing a system fan	139
Replacing the front panel board	141
Replacing the riser card assembly 1	143
Replacing the system board battery	145
Completing the parts replacement	147
Reinstalling the server cover and reconnecting cables	147
Updating the server configuration	151
Chapter 7. Troubleshooting and diagnostics	153
Troubleshooting procedure	153
Viewing the status and diagnostic LEDs.	153
Viewing the system event log	153
Basic troubleshooting tables	154
ThinkServer EasyStartup program problems	154
Optical drive problems.	154
Hard disk drive problems.	155

Memory module problems	156
Keyboard, mouse, and USB device problems	157

Chapter 8. Getting information, help, and service 159

Information resources	159
Using the documentation.	159
ThinkServer Web site	159
Lenovo Support Web site.	159
Help and service	160
Before you call	160
Calling for service.	160
Using other services	161
Purchasing additional services	161

Appendix A. Notices 163

Trademarks	164
Important notes	164
Polyvinyl Chloride (PVC) cable and cord notice	164
Recycling information	164
Battery return program.	165
Requirement for batteries containing perchlorate	165
Particulate contamination	166
Important information for the European Directive 2002/96/EC	166
German Ordinance for Work gloss statement.	170
Export classification notice	170
Electronic emission notices.	170
Federal Communications Commission (FCC) Statement.	170
ENERGY STAR model information	172

Index. 173

Safety information

Note: Before using the product, be sure to read and understand the multilingual safety instructions on the documentation DVD that comes with the product.

قبل استخدام المنتج، تأكد من قراءة إرشادات الأمان متعددة اللغات وفهمها، وتوجد هذه الإرشادات في قرص DVD الوثائقي الذي يأتي مع المنتج.

Antes de usar o produto, leia e entenda as instruções de segurança multilíngues no DVD de documentação que o acompanha.

Преди да използвате този продукт, задължително прочетете и вникнете в многоезичните инструкции за безопасност в DVD диска с документация, който се предоставя с продукта.

Prije upotrebe ovog proizvoda obavezno pročitajte višejezične sigurnosne upute koje se nalaze na DVD-u s dokumentacijom koji dobivate uz proizvod.

Před použitím produktu je třeba si přečíst a porozumět bezpečnostním pokynům uvedeným na disku DVD s dokumentací, který je dodáván s produktem.

Før du bruger produktet, skal du sørge for at læse og forstå de sikkerhedsforskrifter, der findes på flere sprog, på den dokumentations-dvd, der følger med produktet.

Lue tuotteen mukana toimitetulla DVD-tietolevyllä olevat monikieliset turvaohjeet ennen tämän tuotteen käyttöä.

Avant d'utiliser le produit, veuillez à bien lire et comprendre les instructions de sécurité multilingues figurant sur le DVD de documentation fourni avec le produit.

Πριν χρησιμοποιήσετε το προϊόν, βεβαιωθείτε ότι έχετε διαβάσει και κατανοήσει τις οδηγίες ασφάλειας, οι οποίες είναι διαθέσιμες σε διάφορες γλώσσες στο DVD τεκμηρίωσης που συνοδεύει το προϊόν.

Vor Verwendung des Produkts sollten Sie unbedingt die mehrsprachigen Sicherheitsanweisungen auf der Dokumentations-DVD lesen, die im Lieferumfang des Produkts enthalten ist.

לפני השימוש במוצר, הקפידו לקרוא ולהבין את הוראות הבטיחות, המופיעות בשפות שונות ב-DVD התיעוד המצורף למוצר.

A termék használata előtt mindenképpen olvassa el és értelmezze a termékhez kapott dokumentációs DVD lemezen található, több nyelven elolvasható biztonsági előírásokat.

Prima di utilizzare il prodotto, accertarsi di leggere e comprendere le informazioni sulla sicurezza multilingue disponibili sul DVD di documentazione fornito con il prodotto.

製品をご使用になる前に、製品に付属の Documentation DVD に収録されているマルチリンガルの「安全に正しくご使用いただくために」を読んで理解してください。

제품을 사용하기 전에 제품과 함께 제공되는 문서 DVD의 다국어 안전 지침을 주의 깊게 읽어보십시오.

Voordat u het product gebruikt, moet u ervoor zorgen dat u de meertalige veiligheidsinstructies op de documentatie-dvd van het product hebt gelezen en begrijpt.

Przed skorzystaniem z produktu należy zapoznać się z wielojęzycznymi instrukcjami bezpieczeństwa znajdującymi się na płycie DVD z dokumentacją dostarczoną wraz z produktem.

Antes de utilizar o produto, leia atentamente as instruções de segurança multilíngues que constam no DVD de documentação fornecido com o produto.

Înainte de a utiliza produsul, asigurați-vă că ați citit și înțeles instrucțiunile de siguranță în mai multe limbi de pe DVD-ul cu documentație care însoțește produsul.

Før du bruker produktet, må du lese og forstå den flerspråklige sikkerhetsinformasjonen på DVDen med dokumentasjon som følger med produktet.

Прежде чем использовать этот продукт, внимательно ознакомьтесь с инструкциями по технике безопасности на разных языках, которые можно найти на DVD-диске с документацией в комплекте с продуктом.

在使用本产品之前，请务必先阅读和了解产品附带的文档 DVD 中的多语言安全说明。

Pre nego to upotrebite proizvod obavezno paljivo pročitajte i prouite viejziko uputstvo za bezbednost na dokumentacionom DVD-u koji ste dobili uz proizvod.

Pred pouvanm produktu si pretajte viacjazyn bezpenostn pokyny na disku DVD s dokumentciou dodanom s produktom.

Preden začnete uporabljati izdelek, je pomembno, da preberete in razumete večjezična varnostna navodila na DVD-ju z dokumentacijo, ki ste ga prejeli skupaj z izdelkom.

Antes de utilizar el producto, asegúrese de leer y comprender las instrucciones de seguridad multilingües del DVD de documentación que se proporciona con el producto.

Var noga med att läsa säkerhetsinstruktionerna på dokumentations-DVD-skivan som följer med produkten innan du börjar använda produkten.

使用本產品之前，請務必閱讀並瞭解產品隨附的文件 DVD 上的多國語言版本安全資訊。

Bu ürünü kullanmadan önce, ürünle birlikte gönderilen belge DVD'si üzerindeki çok dil içeren güvenlik yönergelerini okuyup anladığınızdan emin olun.

Перед використанням цього продукту уважно ознайомтеся з інструкціями з техніки безпеки на різних мовах, що можна знайти на DVD-диску з документацією в комплекті з продуктом.

Important: The caution and danger statements in this document are labeled with numbers. Each number identifies an English-language caution or danger statement that refers to translated versions of the caution or danger statement in the *Safety Information* document. For example, if a danger statement is labeled “Statement 1,” translations for this danger statement are in the *Safety Information* document under “Statement 1.”

Ensure that you read and understand all caution and danger statements in this document before you perform the procedures. Read and understand any additional safety information that is included with the server or optional device before you install, remove, or replace the device.

Statement 1



DANGER

Electrical current from power, telephone, and communication cables is hazardous.

To avoid a shock hazard:

- Do not connect or disconnect any cables or perform installation, maintenance, or reconfiguration of this product during an electrical storm.
- Connect all power cords to a properly wired and grounded electrical outlet.
- Connect to properly wired outlets any equipment that will be attached to this product.
- When possible, use one hand only to connect or disconnect signal cables.
- Never turn on any equipment when there is evidence of fire, water, or structural damage.
- Disconnect the attached power cords, telecommunications systems, networks, and modems before you open the device covers, unless instructed otherwise in the installation and configuration procedures.
- Connect and disconnect cables as described in the following table when installing, moving, or opening covers on this product or attached devices.

To connect:

1. Turn everything OFF.
2. First, attach all cables to devices.
3. Attach signal cables to connectors.
4. Attach power cords to outlets.
5. Turn devices ON.

To disconnect:

1. Turn everything OFF.
2. First, remove power cords from outlets.
3. Remove signal cables from connectors.
4. Remove all cables from devices.

Statement 2



DANGER

Danger of explosion if battery is incorrectly replaced.

When replacing the lithium coin cell battery, use only the same or an equivalent type that is recommended by the manufacturer. The battery contains lithium and can explode if not properly used, handled, or disposed of.

Do not:

- Throw or immerse into water
- Heat to more than 100°C (212°F)
- Repair or disassemble

Dispose of the battery as required by local ordinances or regulations.

Statement 3



CAUTION:

When laser products (such as CD-ROMs, DVD drives, fiber optic devices, or transmitters) are installed, note the following:

- Do not remove the covers. Removing the covers of the laser product could result in exposure to hazardous laser radiation. There are no serviceable parts inside the device.
- Use of controls or adjustments or performance of procedures other than those specified herein might result in hazardous radiation exposure.



DANGER

Some laser products contain an embedded Class 3A or Class 3B laser diode. Note the following:

Laser radiation when open. Do not stare into the beam, do not view directly with optical instruments, and avoid direct exposure to the beam.

Statement 4

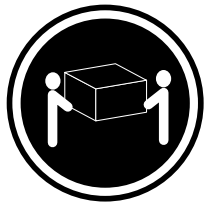

≥ 18 kg (39.7 lb)
 < 32 kg (70.5 lb)

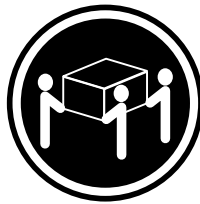

≥ 32 kg (70.5 lb)
 < 55 kg (121.2 lb)

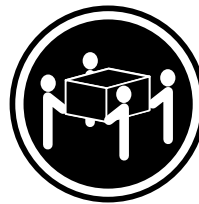

≥ 55 kg (121.2 lb)
 < 100 kg (220.5 lb)

CAUTION:

Use safe practices when lifting.

Statement 5



CAUTION:

The power control button on the device and the power switch on the power supply do not turn off the electrical current supplied to the device. The device also might have more than one power cord. To remove all electrical current from the device, ensure that all power cords are disconnected from the power source.

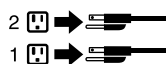

Statement 6



CAUTION:

If you install a strain-relief bracket option over the end of the power cord that is connected to the device, you must connect the other end of the power cord to a power source that is easily accessible in case it needs to be disconnected.

Statement 7



CAUTION:

If the device has doors, ensure that you remove or secure the doors before moving or lifting the device to protect against personal injury. The doors will not support the weight of the device.

Statement 8



CAUTION:

Never remove the cover on a power supply or any part that has the following label attached.



Hazardous voltage, current, and energy levels are present inside any component that has this label attached. There are no serviceable parts inside these components. If you suspect a problem with one of these parts, contact a service technician.

Statement 9



CAUTION:

Disconnect the hot-swap fan cables before removing the fan from the device to protect against personal injury.

Statement 10



CAUTION:

The following label indicates a sharp-edge hazard.



Statement 11



CAUTION:

The following label indicates a potential heat hazard.



Statement 12



DANGER

Overloading a branch circuit is a potential fire hazard and a shock hazard under certain conditions. To avoid these hazards, ensure that your system electrical requirements do not exceed branch current ratings at the installation site.

Statement 13



CAUTION:

Ensure that the rack is secured properly to avoid tipping when the server unit is extended on the rails.

Statement 14



CAUTION:

Some accessory or option board outputs exceed Class 2 or limited power source limits. You must install the appropriate interconnecting cabling in accordance with your local electrical code requirements.

Statement 15



CAUTION:

The power-control button on the device may put the device in standby mode instead of turning off the device. In addition, the device might have multiple connections to dc power. To remove all electrical current from the device, ensure that all connections to dc power are disconnected at the dc power input terminals.

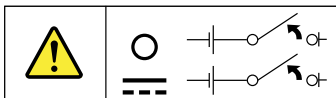

Statement 16



CAUTION:

To reduce the risk of electric shock or energy hazards:

- This equipment must be installed by trained service personnel in a restricted-access location, as defined by your local electrical code and the latest edition of IEC 60950.
- Connect the equipment to a reliably earthed safety extra low voltage (SELV) source. An SELV source is a secondary circuit that is designed so that normal and single fault conditions do not cause the voltages to exceed a safe level (60 V direct current).
- The branch circuit overcurrent protection must be rated in accordance with local electrical code requirements.
- Use 1.3 mm² or 16 American Wire Gauge (AWG) copper conductor only, not exceeding 3 meters in length.
- Torque the wiring-terminal screws to 1.4 newton-meters or 12 inch-pounds.
- Provide a readily available, approved and rated disconnect device in the field wiring.

Statement 17



CAUTION:

This product contains a Class 1M laser. Do not view directly with optical instruments.

Statement 18



CAUTION:

Do not place any object on top of rack-mounted products.



Statement 19



CAUTION:

Hazardous moving parts. Keep fingers and other body parts away.

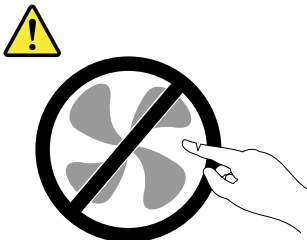

Statement 20



CAUTION:

A lithium ion battery is provided. To avoid possible explosion, do not burn the battery. Replace the battery only with the Lenovo-approved part. Recycle or discard the battery as instructed by local regulations.

Chapter 1. General information

This chapter provides some general information about your product.

This chapter contains the following items:

- “Introduction” on page 1
- “Server documentation” on page 2

Introduction

This user guide for your Lenovo® ThinkServer® product contains information about the server features, specifications, component locations, configuration instructions, hardware replacement procedures, and basic troubleshooting and diagnostics.

Your server comes with a documentation DVD that contains various server documents to help you use and maintain the server. Meanwhile, your server comes with a *ThinkServer EasyStartup* DVD that provides a convenient solution for configuring the server and installing an operating system.

The Lenovo Limited Warranty (LLW) contains the warranty terms that apply to the product you purchased from Lenovo. Read the LLW on the documentation DVD that comes with your server. A printable generic version of the latest LLW also is available in more than 30 languages at http://www.lenovo.com/warranty/llw_01. If you cannot obtain the LLW through the documentation DVD or Lenovo Web site, contact your local Lenovo office or reseller to obtain a printed version of the LLW, free of charge.

For warranty service, consult the worldwide Lenovo Support telephone list. Telephone numbers are subject to change without notice. The most up-to-date telephone list for Lenovo Support is always available on the Web site at <http://www.lenovo.com/support/phone>. If the telephone number for your country or region is not listed, contact your Lenovo reseller or Lenovo marketing representative.

To obtain the most up-to-date information about the server, go to:
<http://www.lenovo.com/thinkserver>

Lenovo maintains pages on the World Wide Web, where you can get the latest technical information and download documentation or device drivers and updates. To access the Lenovo Support Web site, go to:
<http://www.lenovo.com/support>

Record information about your server in the following table. You will need the information if you ever need to have your server serviced.

For where to find the product information label on the chassis, see “Machine type, model, and serial number label” on page 13.

Product name	_____
Machine type and model (MT-M)	_____
Serial number (S/N)	_____
Date of purchase	_____

You can register your server with Lenovo by following the instructions at:
<http://www.lenovo.com/register>

When you register your server, information is entered into a database, which enables Lenovo to contact you in case of a recall or other severe problem. After you register your server with Lenovo, you will receive quicker service when you call Lenovo for help. In addition, some locations offer extended privileges and services to registered users.

Server documentation

This topic provides general descriptions of the various documentation for your server and instructions on how to obtain all the documentation.

Printed documents

The following documents are printed out and contained in your server package.

- *Read Me First*

This is a multilingual document you should read first. This document guides you to read the complete warranty, support, and safety information on the documentation DVD that comes with your server before using the product. This document also provides information about how to find the most up-to-date information on the Lenovo Support Web site.

- *Important Notices*

This document includes safety and legal notices that you should read and understand before using the server.

- *Rack Installation Instructions*

This document provides instructions on how to install your server into a standard rack cabinet by using the rail kit shipped with the server.

Note: This document is available in five languages. A printed English version is included in your server package. A PDF version of French, German, Italian, and Spanish are provided on the documentation DVD that comes with the server.

Documentation DVD

The documentation DVD, which comes with your server, contains various documents for your server in Portable Document Format (PDF) and HyperText Markup Language (HTML). The documentation DVD is not bootable. To view the documents on the DVD, you will need a computer with a Web browser and the Adobe Reader program, which is available for download at:
<http://www.adobe.com>

To start the documentation DVD, insert the DVD into the optical drive. The DVD is AutoPlay enabled and starts automatically in most Microsoft® Windows® environments. If the DVD fails to start or if you are using a Linux® operating system, open the launch.htm file located in the root directory of the DVD.

Note: Lenovo maintains pages on the World Wide Web, where you can get the latest technical information and download documentation or device drivers and updates. Some information in the documents on the documentation DVD might change without notice after the first release of the DVD. You can always obtain all the most up-to-date documentation for your server from the Lenovo Web site at:
<http://www.lenovo.com/ThinkServerUserGuides>

The following documents are on the documentation DVD that comes with your server:

- *Safety Information*
This is a multilingual document that includes all the safety statements for your product in more than 30 languages. Be sure to read and understand all the safety statements before using the product.
- *Warranty and Support Information*
This document includes the Lenovo warranty statement, Customer Replaceable Units (CRUs) information, and information about how to contact Lenovo Support.
- *Lenovo License Agreement*
This document includes the terms and conditions of the Lenovo License Agreement.
- *User Guide*
This document provides detailed information to help you get familiar with your server and help you use, configure, and maintain your server.
- *Rack Installation Instructions*
This document provides instructions on how to install your server into a standard rack cabinet by using the rail kit shipped with the server.
- *ThinkServer Management Module User Guide*
This document provides information about server remote management. This document is in English only. You might find this document on the documentation DVD that comes with your server. If not, download it from the Lenovo Web site at:
<http://www.lenovo.com/ThinkServerUserGuides>

Note: To obtain advanced remote management functions, install a ThinkServer Management Module Premium (TMM Premium) on the TMM Premium connector on the system board. See “Installing or removing the ThinkServer Management Module Premium” on page 100.

- *MegaRAID SAS Software User Guide*

This document provides information about Redundant Array of Independent Disks (RAID) and how to use the utility programs to configure, monitor, and maintain your server RAID and related devices. This document is in English only.

Note: Refer to this document for hardware RAID information if you have a required RAID card installed in the server. See “Installing or removing the RAID card” on page 85. For information about the ThinkServer RAID 300 (also known as the onboard SAS software RAID), see “Configuring the ThinkServer RAID 300” on page 58.

Document only for trained service personnel

The following document is intended only for trained service personnel of Lenovo.

Hardware Maintenance Manual

This document provides information about component locations, replacement procedures for major Field Replaceable Units (FRUs), and troubleshooting and diagnostics. This document is updated frequently, and the most up-to-date version is always available in English on the Lenovo Web site at:
<http://www.lenovo.com/ThinkServerUserGuides>

Chapter 2. Server setup road map

This chapter provides a general road map to guide you through setting up your server.

The server setup procedure varies depending on the configuration of the server when it was delivered. In some cases, the server is fully configured and you just need to connect the server to the network and an ac power source, and then you can turn on the server. In other cases, the server needs to have hardware features installed, requires hardware and firmware configuration, and requires an operating system to be installed.

The general procedure for setting up your server is:

1. Unpack the server package. See “Server package” on page 7.
2. Install any required hardware or server option. See the related topics in Chapter 6 “Installing, removing, or replacing hardware” on page 67.
3. Install your server into a standard rack cabinet by using the rail kit shipped with the server. See *Rack Installation Instructions* that comes with your server.
4. Connect the Ethernet cable and power cord(s) to the server. See “Rear view of the server” on page 20 to locate the connectors.
5. Turn on the server to verify operation. See “Turning on the server” on page 43.
6. Review the Unified Extensible Firmware Interface (UEFI) settings and customize as needed. See “Using the Setup Utility program” on page 45.
7. Configure RAID and install the operating system and basic drivers. See “Using the ThinkServer EasyStartup program” on page 53 and “Configuring RAID” on page 56.
8. Install any additional drivers needed for added features. Refer to the instructions that come with the hardware option.
9. Configure Ethernet settings in the operating system by referring to the operating system help. This step is not required if the operating system was installed using the ThinkServer EasyStartup program.
10. Check for firmware and driver updates. See “Updating the firmware” on page 64.
11. Install other applications. Refer to the documentation that comes with the applications that you want to install.

Chapter 3. Product overview

This chapter provides information about the server package, features, specifications, software programs, and component locations.

This chapter contains the following items:

- “Server package” on page 7
- “Features” on page 7
- “Specifications” on page 11
- “Software” on page 11
- “Locations” on page 13

Server package

The server package includes the server, a rail kit, power cord(s), printed documentation, a documentation DVD, and software media.

Note: Depending on the model, your server might look slightly different from the illustration in this topic.

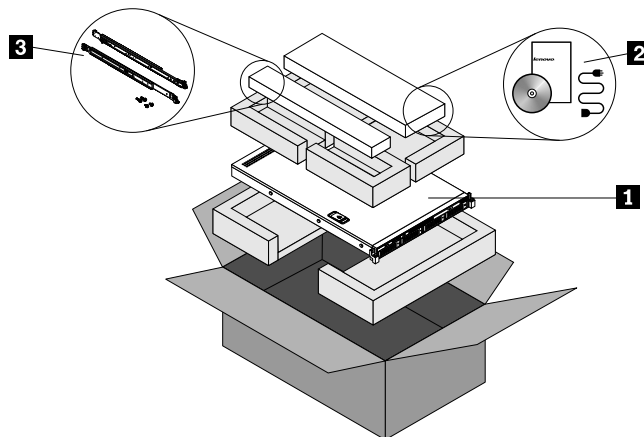

Figure 1. Server package

- 1** Server
- 2** Material box, including power cord(s), printed documentation, a documentation DVD, and software media
- 3** Rail kit

Features

This topic provides general information about the server features for a variety of models. Depending on your specific model, some features might vary or not be available. For information about your specific model, use the Setup Utility program. See “Viewing information in the Setup Utility program” on page 45.

Microprocessor

One or two Intel® Xeon® quad-core, hexa-core, or octa-core microprocessors (internal cache size varies by model)

For a list of the ThinkServer microprocessor options, go to:
<http://www.lenovo.com/thinkserver>

Memory

Your server has 12 memory slots. For more information, see “Memory module installation rules” on page 75.

Power supply

One or two 550-watt hot-swap redundant power supplies (Universal input and compliant with 80 PLUS Gold)

System fans

Your server comes with six system fans to provide proper system cooling and airflow.

Internal drives

Internal drives are devices that your server uses to read and store data. The internal drives supported by your server vary by model.

- Hard disk drive
 - Up to four 3.5-inch hot-swap Serial Advanced Technology Attachment (SATA) or Serial Attached SCSI (SAS) hard disk drives (SCSI is the acronym for Small Computer System Interface)
 - Up to six 2.5-inch hot-swap SAS hard disk drives or SATA solid-state drives

Note: The term “2.5-inch hot-swap hard disk drives” or “2.5-inch hard disk drives” hereinafter refers to all the supported types of 2.5-inch hard disk drives, including the solid-state drives.

- Optical drive
 - One slim SATA optical drive in some models

For the location information about the internal drives or drive bays, see “Server components” on page 22.

Expansion slots

- Two riser card assembly slots on the system board
- One PCI Express card slot on the riser card assembly 1
- One PCI Express card slot on the riser card assembly 2

For detailed information, see “Rear view of the server” on page 20.

Input/Output (I/O) features

- One or two Video Graphics Array (VGA) DB-15 connectors
- One serial connector on the rear panel
- Six USB 2.0 connectors (two on the front panel and four on the rear panel)
- Three RJ-45 Ethernet connectors on the rear panel (Ethernet connector 0 is for system management)

For the location information about the connectors, refer to the related topics in “Locations” on page 13.

Video subsystem

An integrated graphics controller in the ThinkServer Management Module (TMM), which also is known as the Baseboard Management Controller (BMC) chip, on the system board to support VGA connectors for connecting video devices

Ethernet connectivity

Three RJ-45 Ethernet connectors on the rear panel with 10 megabits per second (Mbps), 100 Mbps, or 1000 Mbps network connectivity.

- Onboard Intel 82574L Gigabit Ethernet controller for dedicated or shared local area network (LAN) management interface (Ethernet connector 0 is for system management)
- Onboard Intel Gigabit Dual Port Ethernet controller for Ethernet connector 1 and Ethernet connector 2

For more information, see “Rear view of the server” on page 20.

Reliability, availability, and serviceability

Reliability, availability, and serviceability (hereinafter referred to as RAS) are three important server design features. The RAS features help you to ensure the integrity of the data stored on the server, the availability of the server when you need it, and the ease with which you can diagnose and correct problems.

Your server has the following RAS features:

- **Security features**

- Administrator password and user password to help protect unauthorized access to the server (see “Using passwords” on page 49)
- ThinkServer Trusted Platform Module (TPM), which is a security chip, to help enhance server security

Note: The TPM is only available in some models.

- Remote monitoring or control by an administrator to provide protection or help
- Hot-swap redundant power supplies to help avoid significant interruption to the operation of the system when a power supply fails

- **Basic system management features**

- Ability to store the power-on self-test (POST) hardware test results
- BIOS Setup Utility program

The BIOS Setup Utility program helps you view the server information and configure the server in the pre-operating system environment. See “Using the Setup Utility program” on page 45.

- TMM (also known as BMC) and Intelligent Platform Management Interface (IPMI) 2.0

The system board platform management subsystem is based on the integrated TMM features. The TMM is a management chip that is integrated on the system board of your server. With the TMM chip, no matter what condition the server operating system is in and no matter if the server is on or off, as long as the server is connected to network and an ac power source, the interaction with the TMM-controlled servers can be achieved through system network. The user can obtain the server hardware health information and system event log (SEL), and is able to conduct the operations including turning on or off the server, restarting the server, locking the power switch on the front panel, and so on. This part of server management is independent of the operating system and is called out-of-band management.

The system board platform management subsystem consists of the integrated TMM, communication buses, sensors, the BIOS, and server management firmware. It is responsible for error reporting, system power control, thermal monitoring, system fan control, and other management features. The TMM provides system management and monitoring features based on the IPMI 2.0 specification. IPMI

helps lower the overall costs of server management. You can find more information about IPMI 2.0 from the Web site of Intel. The TMM also supports some non-IPMI features, such as the Dynamic Host Configuration Protocol (DHCP) and the Platform Environment Control Interface (PECI), to provide more system management functions.

For more information, refer to the *ThinkServer Management Module User Guide*, which is available for download at:

<http://www.lenovo.com/ThinkServerUserGuides>

- Hot-swap feature

Your server supports hot-swap hard disk drives and hot-swap redundant power supplies. With the hot-swap feature, you can install, remove, or replace a hot-swap device without turning off the server.

- Preboot Execution Environment (PXE)

The Intel PXE technology enables you to boot your computers, load an operating system, or deploy executable images from a remote server by using a network interface. The operation can be done independently of local data storage devices (such as hard disk drives) or operating systems.

- Redundant Array of Independent Disks (RAID)

Your server supports ThinkServer RAID 300 and advanced SATA/SAS hardware RAID configurations if you have a required RAID card installed. For detailed information, see “Configuring RAID” on page 56.

- Status light-emitting diodes (LEDs) and diagnostic LEDs

For more information about the LEDs for your server, refer to the related topics in “Locations” on page 13.

- Software programs

For more information about the software programs, see “Software” on page 11.

- Wake on LAN

When the Wake on LAN feature is enabled on a computer that is connected to a LAN, a network administrator can remotely turn on or wake up the computer from a management console using remote network management software. Besides, many other functions, such as data transfer and software updates, can be performed remotely without remote attendance and can be done after normal working hours and on weekends to save time and increase productivity.

- **Advanced system management features**

The advanced system management features are only available when the TMM detects the presence of a ThinkServer Management Module Premium (TMM Premium), which also is known as integrated keyboard, video, and mouse (iKVM) key. The TMM Premium is a remote management module. You can purchase a TMM Premium from Lenovo and install it on the TMM Premium connector (also known as iKVM connector) on the system board of your server to enable the iKVM function and activate the advanced system management features.

For more information about advanced system management, refer to the *ThinkServer Management Module User Guide*, which is available for download at:

<http://www.lenovo.com/ThinkServerUserGuides>

Specifications

This topic lists the physical specifications for your server.

Dimensions

Width: 436 mm (17.17 inches) without handles; 482.4 mm (18.99 inches) with handles

Height: 43.6 mm (1.72 inches)

Depth: 720.6 mm (28.37 inches) without handles; 734 mm (28.90 inches) with handles

Weight

The product weight varies depending on different system configurations.

Range of product weight without package: 12 kg (26.46 lb) to 17 kg (37.48 lb)

Range of product weight with package : 15 kg (33.07 lb) to 24 kg (52.91 lb)

Environment

- Air temperature:

- Operating: 10°C to 35°C (50°F to 95°F)

- Storage: -40°C to 70°C (-40°F to 158°F) in original shipping package

- Altitude: 0 to 3048 m (0 to 10 000 ft) in an unpressurized environment

- Humidity:

- Operating: 8% to 80% (non-condensing)

- Storage without package: 8% to 80% (non-condensing)

- Storage with package: 8% to 90% (non-condensing)

Electrical input

- Universal input:

- Low range:

- Minimum: 100 V ac

- Maximum: 127 V ac

- Input frequency range: 50 to 60 Hz

- High range:

- Minimum: 200 V ac

- Maximum: 240 V ac

- Input frequency range: 50 to 60 Hz

Software

This topic provides information about the software programs that you can use to set up, use, and maintain the server.

ThinkServer EasyStartup

The ThinkServer EasyStartup program simplifies the process of configuring RAID and installing supported Microsoft Windows and Linux operating systems and device drivers on your server. This program is provided with your server on a self-starting (bootable) *ThinkServer EasyStartup* DVD. The user guide for the program also is on the DVD and can be accessed directly from the program interface. For detailed information, see “Using the ThinkServer EasyStartup program” on page 53.

ThinkServer EasyUpdate Firmware Updater

The ThinkServer EasyUpdate Firmware Updater program (hereinafter referred to as the Firmware Updater program) enables you to maintain your server firmware up-to-date and helps you avoid unnecessary server outages. The Firmware Updater program is provided on the Lenovo Support Web site. For more information about downloading and using the Firmware Updater program, see “Updating the firmware” on page 64.

Lenovo ThinkServer EasyManage

The Lenovo ThinkServer EasyManage program enables enterprise users to remotely control and monitor multiple Lenovo servers within a LAN.

For detailed information, see “Using the Lenovo ThinkServer EasyManage program” on page 65.

BIOS and TMM update utilities

The BIOS and TMM (also known as BMC) firmware keeps updating after the shipment of the server. Lenovo maintains pages on the Support Web site and provides the BIOS and TMM update utilities with instructions for download to help you update the BIOS and TMM firmware if needed. For more information, see “Updating or recovering the BIOS” on page 51 and “Updating the firmware” on page 64.

RAID configuration utilities

With some RAID configuration utilities, your server supports ThinkServer RAID 300 and advanced SATA/SAS hardware RAID if a required RAID card is installed. For detailed information, see “Configuring RAID” on page 56.

Remote management software

The integrated TMM provides basic remote management features for the server. The add-on TMM Premium option provides advanced remote management features for the server.

For detailed information about the remote management software and server remote management, refer to the *ThinkServer Management Module User Guide*, which is available for download at: <http://www.lenovo.com/ThinkServerUserGuides>

Lenovo Rack Planner

Racks and servers are usually deployed on a large scale. When deploying the equipment, equipment managers need a lot of reference parameters to calculate power consumption and electric current values under different configurations. The Lenovo Rack Planner program provides data maintenance, power consumption and electric current calculations, and reports to help equipment managers significantly increase efficiency in deploying the equipment and conveniently manage the equipment.

To download the Lenovo Rack Planner program, go to <http://www.lenovo.com/drivers> and follow the instructions on the Web page.

For detailed information about using the Lenovo Rack Planner program, refer to the help system for the program.

ThinkServer Smart Grid Technology

The ThinkServer Smart Grid Technology program helps administrators to monitor and manage server performance, especially the power consumption for groups of servers equipped with the Intel Intelligent Power Node Manager technology.

Lenovo provides a trial version of the ThinkServer Smart Grid Technology program with a free 90-day subscription. After 90 days, you must renew the license to continue using the program. You can purchase the license from Lenovo to activate the ThinkServer Smart Grid Technology program and expand the management capability of the program when the free trial ends.

To download the ThinkServer Smart Grid Technology program, go to <http://www.lenovo.com/drivers> and follow the instructions on the Web page.

For detailed information about using the ThinkServer Smart Grid Technology program, refer to the help system for the program.

Locations

This topic provides information to help you locate your server components.

Machine type, model, and serial number label

This topic helps you locate the label that contains the machine type, model, and serial number information for your server.

When you contact Lenovo for help, the machine type, model, and serial number information helps support technicians to identify your server and provide faster service.

The machine type, model, and serial number label is attached on the pull-out information card, which is a small plastic tab and can be slid out of the front of the chassis. The following illustrations are samples of the machine type, model, and serial number labels on server models with different hard disk drive configurations.

Note: Depending on the model, your server might look slightly different from the illustrations in this topic.

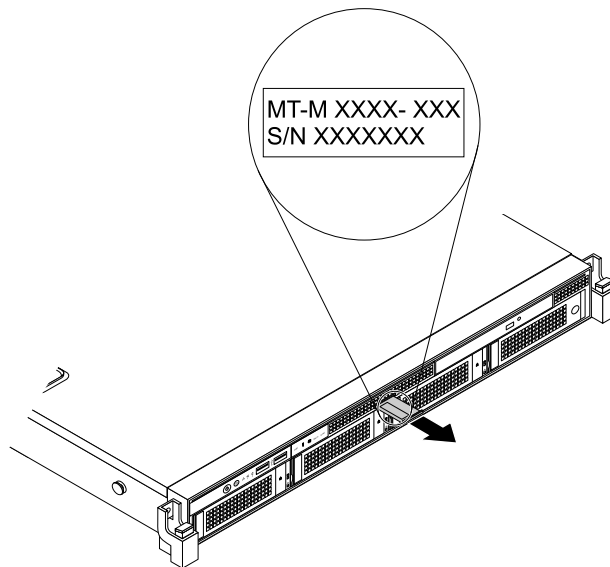

Figure 2. Label on server models with 3.5-inch hard disk drives

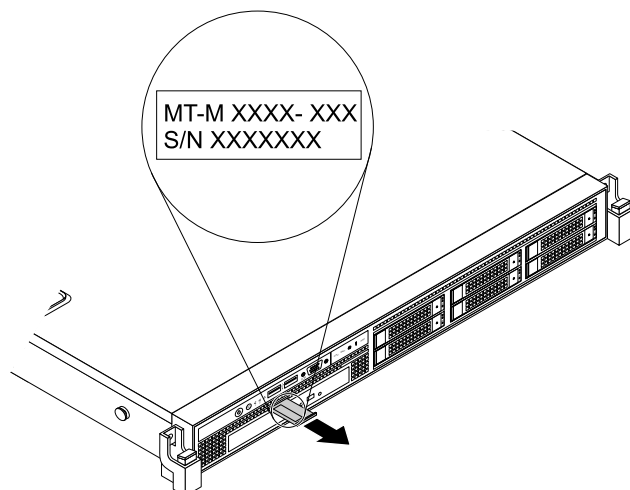

Figure 3. Label on server models with 2.5-inch hard disk drives

Front view of the server

This topic provides information to help you locate the parts on the front of the server.

The front view of the server varies by model. The illustrations in this topic show the server front views based on the supported hard disk drives:

- Front view of server models with 3.5-inch hard disk drives
- Front view of server models with 2.5-inch hard disk drives

Note: Depending on the model, your server might look slightly different from the illustrations in this topic.

Front view of server models with 3.5-inch hard disk drives

The following illustration shows the front view of server models with 3.5-inch hard disk drives.

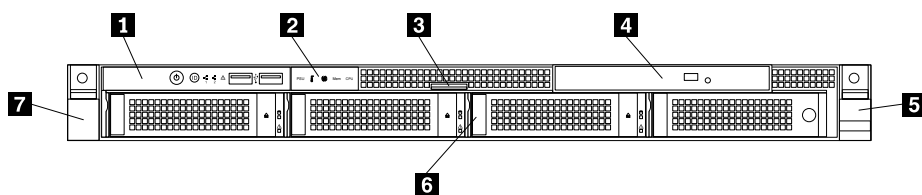

Figure 4. Front view of server models with 3.5-inch hard disk drives

1 Front panel	5 Right rack handle
2 Intelligent Diagnostics Module	6 3.5-inch hard disk drive area
3 Pull-out information card	7 Left rack handle
4 Slim optical drive (available in some models)	

1 Front panel

For detailed information about the controls, connectors, and status LEDs on the front panel, see “Front panel” on page 17.

2 Intelligent Diagnostics Module

For more information, see “Intelligent Diagnostics Module” on page 19.

3 Pull-out information card

The machine type, model, and serial number label of the server is attached on the pull-out information card. See “Machine type, model, and serial number label” on page 13.

4 Slim optical drive

Some server models come with a slim SATA optical drive.

5 Right rack handle

7 Left rack handle

If your server is installed in a rack cabinet, you can use the rack handles to slide the server out of the rack cabinet; or use the rack handles and screws to secure the server in the rack cabinet so that the server cannot slide out, especially in vibration-prone areas. For more information, refer to the *Rack Installation Instructions* that comes with your server.

6 3.5-inch hard disk drive area

The EMI integrity and cooling of the server are protected by having all drive bays covered or occupied. The number of the installed hard disk drives in your server varies by model. The vacant hard disk drive bays are occupied by dummy hard disk drive trays.

The hard disk drive bay numbers are marked on the top edge of the front bezel.

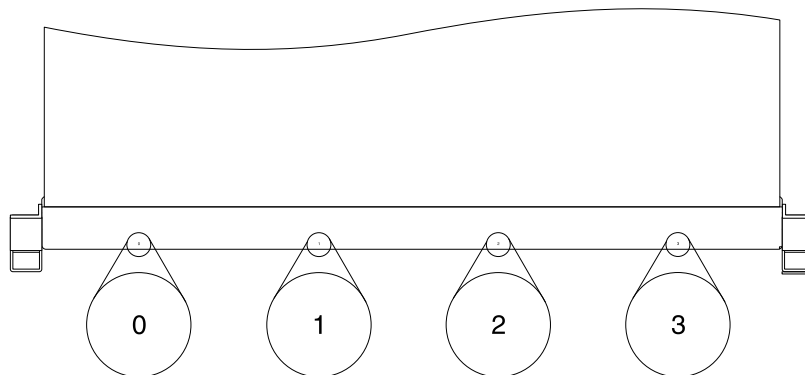

Figure 5. 3.5-inch hard disk drive bay numbers (top view of the server)

Front view of server models with 2.5-inch hard disk drives

The following illustration shows the front view of server models with 2.5-inch hard disk drives.

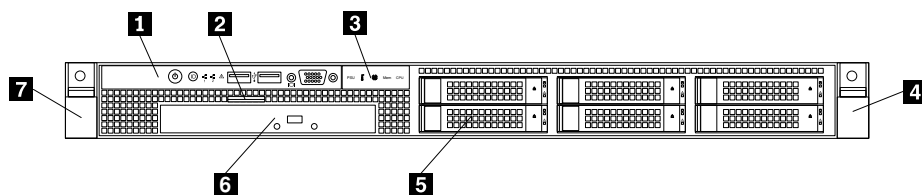

Figure 6. Front view of server models with 2.5-inch hard disk drives

1 Front panel	5 2.5-inch hard disk drive area
2 Pull-out information card	6 Slim optical drive (available in some models)
3 Intelligent Diagnostics Module	7 Left rack handle
4 Right rack handle	

1 Front panel

For detailed information about the controls, connectors, and status LEDs on the front panel, see “Front panel” on page 17.

2 Pull-out information card

The machine type, model, and serial number label of the server is attached on the pull-out information card. See “Machine type, model, and serial number label” on page 13.

3 Intelligent Diagnostics Module

For more information, see “Intelligent Diagnostics Module” on page 19.

4 Right rack handle

7 Left rack handle

If your server is installed in a rack cabinet, you can use the rack handles to slide the server out of the rack cabinet; or use the rack handles and screws to secure the server in the rack cabinet so that the server cannot slide out, especially in vibration-prone areas. For more information, refer to the *Rack Installation Instructions* that comes with your server.

5 2.5-inch hard disk drive area

The EMI integrity and cooling of the server are protected by having all drive bays covered or occupied. The number of the installed hard disk drives in your server varies by model. The vacant hard disk drive bays are occupied by dummy hard disk drive trays.

The hard disk drive bay numbers are marked on the top edge of the front bezel.

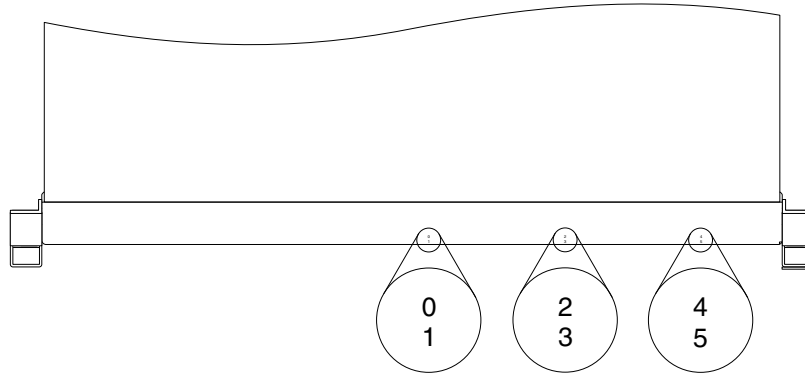

Figure 7. 2.5-inch hard disk drive bay numbers (top view of the server)

6 Slim optical drive

Some server models come with a slim SATA optical drive.

Front panel

This topic provides information to help you locate the controls, connectors, and LEDs on the front panel of the server.

The following illustration shows the controls, connectors, and LEDs on the front panel of the server.

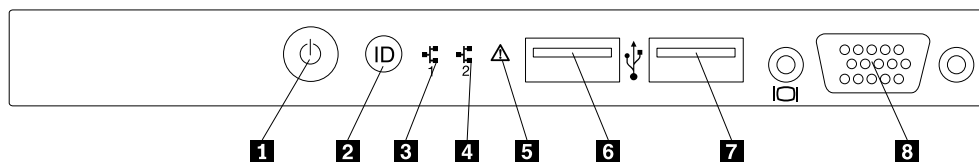

Figure 8. Front panel

1 Power switch with power status LED	5 System error LED
2 ID button with ID LED	6 Front USB connector 1
3 Network Interface Controller (NIC) 1 status LED	7 Front USB connector 2
4 NIC 2 status LED	8 Front VGA DB-15 connector

Note: The front VGA DB-15 connector is only available in server models with 2.5-inch hard disk drives.

1 Power switch with power status LED

You can press the power switch to turn on the server when you finish setting up the server. You also can hold the power switch for several seconds to turn off the server if you cannot turn it off from the operating system. See Chapter 4 “Turning on and turning off the server” on page 43. The power status LED helps you to determine the current power status.

Power status LED	Color	Description
On	Green	The server is on.
Off	None	The server is off.
Blinking	Green	The server is in ACPI S1 mode, which also is known as Power On Suspend (POS) mode. In this mode, the microprocessor is not working while other hardware devices are still working.

2 ID button with ID LED

When you press the ID button, the ID LEDs on both the front and rear of the server are lit to help you locate the server among other servers. You also can turn on the ID LEDs using a remote management program for server presence detection.

ID LED	Color	Description
On	Blue	The server is identified.
Off	None	The ID LED is not in use or the server is not identified.

3 NIC 1 status LED

4 NIC 2 status LED

The two NIC status LEDs indicate the LAN status for the Ethernet connector 1 and Ethernet connector 2 on the rear panel of the server.

NIC status LED	Color	Description
On	Green	The server is connected to a LAN.
Off	None	The server is disconnected from a LAN.
Blinking	Green	The LAN is connected and active.

5 System error LED

The system error LED helps you to determine if there are any system errors.

System error LED	Color	Description
On	Amber	A main component has failed.
Off	None	The server is off or the server is on and is working correctly.

6 Front USB connector 1

7 Front USB connector 2

Used to attach a USB-compatible device, such as a USB keyboard, mouse, scanner, or printer. If you have more than six USB devices, you can purchase a USB hub, which you can use to connect additional USB devices.

8 Front VGA DB-15 connector

Used to attach a VGA-compatible video device, such as a VGA monitor.

Intelligent Diagnostics Module

This topic provides information about the Intelligent Diagnostics Module (hereinafter referred to as the IDM) and the diagnostic LEDs on the module. Many errors are first indicated by a lit error LED on the diagnostic panel of the server. If an LED is lit, one or more LEDs elsewhere in the server might also be lit to direct you to the source of the error. See “System board LEDs” on page 39.

The following illustration shows the location of the IDM and the diagnostic LEDs on the IDM panel. Depending on the model, your server might look slightly different from the illustration in this topic.

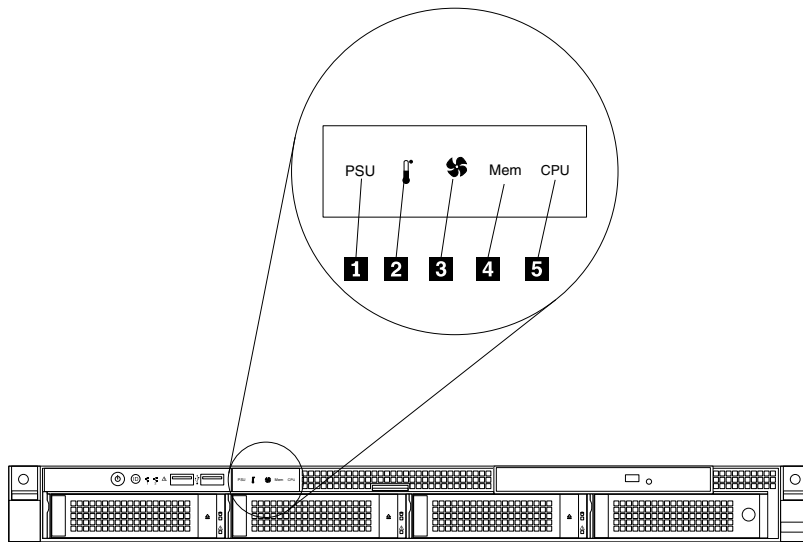

Figure 9. IDM panel

1 Power supply error LED	4 Memory module status LED
2 Ambient temperature limit LED	5 Microprocessor status LED
3 System fan error LED	

1 Power supply error LED

When the power supply error LED is lit in amber, it indicates that there is a power supply problem. To identify the failing power supply, check the status LED near the power cord connector on the redundant power supply. When the status LED is lit in green, it indicates that the power supply is working correctly. When the status LED is lit in amber, it indicates that the power supply is likely to fail or has failed.

2 Ambient temperature limit LED

When this LED is lit in amber, it indicates that the ambient temperature is below 7°C (44.6°F) or over 40°C (104°F), which is not proper for server operation.

3 System fan error LED

When the system fan error LED is lit in amber, it indicates that one or more system fans are operating slowly or have failed. To identify the failing system fan(s), check the status LEDs on the system board. See “System board LEDs” on page 39.

4 Memory module status LED

When the memory module status LED is lit in amber, it indicates that one or more memory modules are overheated.

5 Microprocessor status LED (also known as CPU error LED)

When the microprocessor status LED is lit in amber, it indicates that one or more microprocessors are overheated.

Rear view of the server

This topic provides information to help you locate the connectors and components on the rear of your server.

The following illustration shows the rear view of the server with two hot-swap power supplies.

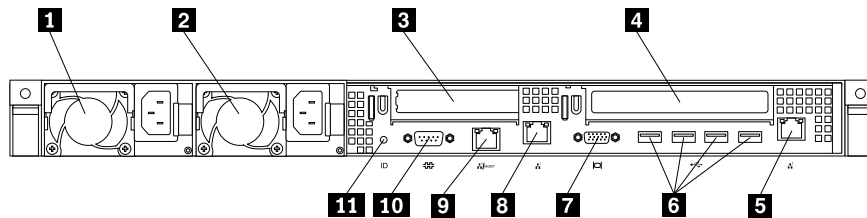

Figure 10. Rear view of the server

1 Hot-swap redundant power supply 2 (available in some models)	7 VGA DB-15 connector
2 Hot-swap redundant power supply 1	8 Ethernet connector 1 (RJ-45)
3 Low-profile PCI Express card slot	9 Ethernet connector 0 for system management (RJ-45)
4 PCI Express card slot	10 Serial port
5 Ethernet connector 2 (RJ-45)	11 ID LED
6 USB connectors (4)	

1 Hot-swap redundant power supply 2 (available in some models)

2 Hot-swap redundant power supply 1

The hot-swap redundant power supplies help you avoid significant interruption to the operation of the system when a power supply fails. You can purchase a hot-swap redundant power supply option directly from Lenovo and install the power supply to provide power redundancy without turning off the server.

On each hot-swap redundant power supply, there is a status LED near the power cord connector. When the LED is lit in green, it indicates that the hot-swap redundant power supply is working correctly. When the LED is lit in amber, it indicates that the hot-swap redundant power supply is likely to fail or has failed.

3 Low-profile PCI Express card slot

It is recommended to attach a RAID card to the low-profile PCI Express card slot.

Physical link width	Negotiable link width	Supported card length and height
x8	x4, x2, x1	Low-profile card

4 PCI Express card slot

Used to attach an Ethernet card or any other supported PCI Express card.

Physical link width	Negotiable link width	Supported card length and height
x16	x16, x8, x4, x2, x1	Half-length, full-height card

5 8 9 Ethernet connectors (RJ-45)

Used to attach an Ethernet cable for a LAN. Each Ethernet connector has two status LEDs to help you identify the Ethernet connectivity, activity, and connection speed.

Notes:

- The Ethernet connector 0 (callout **9**) marked with “MGMT” is for system management. If you want to use remote management functions, you need to connect an Ethernet cable to the Ethernet connector 0.
- The Ethernet connector 0 for system management is 82574L by default. If you have selected share mode for the 82574L Ethernet connector in the Setup Utility program, you can use it as an ordinary Ethernet connector with 100 Mbps network connectivity. However, teaming with other Ethernet connectors is not supported if the management Ethernet connector is used as an ordinary Ethernet connector. For detailed information about setting the mode of the Ethernet connector for system management, see “Setting the mode of the Ethernet connector 0” on page 51.

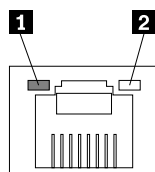

Figure 11. Ethernet status LEDs

Ethernet status LED	Color	Status	Description
1 Left	Amber	On	The connection speed is 1000 Mbps.
	Green	On	The connection speed is 100 Mbps.
	None	Off	The connection speed is 10 Mbps.
2 Right	Green	On	The server is connected to a LAN.
	None	Off	The server is disconnected from a LAN.
	Green	Blinking	The LAN is connected and active.

6 USB connectors (4)

Used to attach a USB-compatible device, such as a USB keyboard, mouse, scanner, or printer. If you have more than six USB devices, you can purchase a USB hub, which you can use to connect additional USB devices.

7 VGA DB-15 connector

Used to attach a VGA-compatible video device, such as a VGA monitor.

10 Serial port

Used to attach a device that uses a 9-pin serial port.

11 ID LED

When you press the ID button, the ID LEDs on both the front and rear of the server are lit to help you locate the server among other servers. You also can turn on the ID LEDs using a remote management program for server presence detection.

ID LED	Color	Description
On	Blue	The server is identified.
Off	None	The ID LED is not in use or the server is not identified.

Server components

This topic provides information to help you locate the components of your server. For more information about major components, see the related topics in “Locations” on page 13.

To remove the server cover and the cooling shroud and gain access to the inside of the server, see “Removing the server cover” on page 69 and “Removing and reinstalling the cooling shroud” on page 73.

The chassis configuration varies by model. The following illustrations show the two chassis configurations based on the supported hard disk drives.

- Server models with 3.5-inch hot-swap hard disk drives
- Server models with 2.5-inch hot-swap hard disk drives

Note: Depending on the model, your server might look slightly different from the illustrations in this topic.

Components of server models with 3.5-inch hot-swap hard disk drives

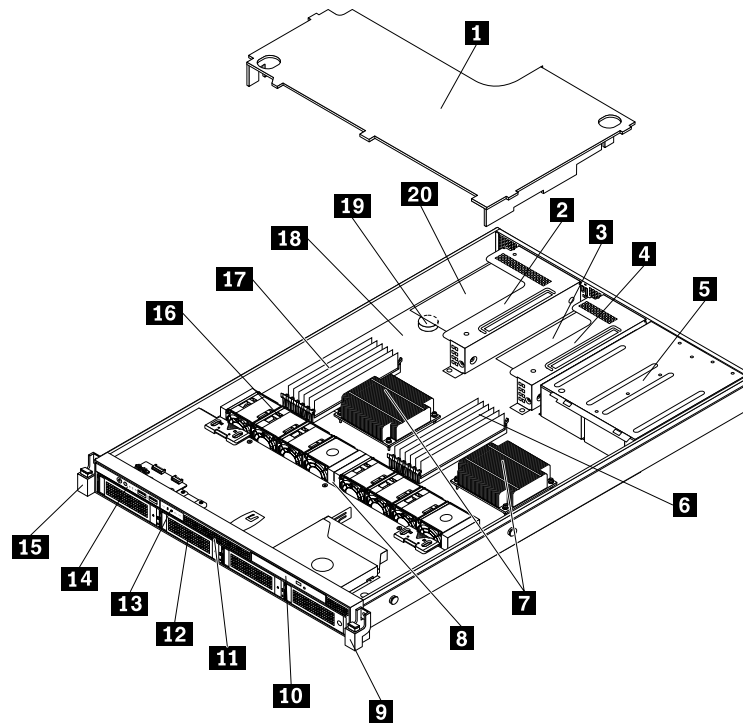

Figure 12. Components of server models with 3.5-inch hot-swap hard disk drives

1 Cooling shroud	11 Pull-out information card
2 Riser card assembly 1	12 3.5-inch hard disk drive bays
3 PCI Express card (available in some models)	13 Intelligent Diagnostics Module
4 Riser card assembly 2	14 Front panel
5 One or two hot-swap redundant power supplies	15 Left rack handle
6 CPU2 DIMMs (vary by model)	16 System fans
7 Heat sinks (vary by model)	17 CPU1 DIMMs (vary by model)
8 Backplane for 3.5-inch hard disk drives	18 System board
9 Right rack handle	19 System board battery
10 Slim optical drive (available in some models)	20 PCI Express card (available in some models)

Components of server models with 2.5-inch hot-swap hard disk drives

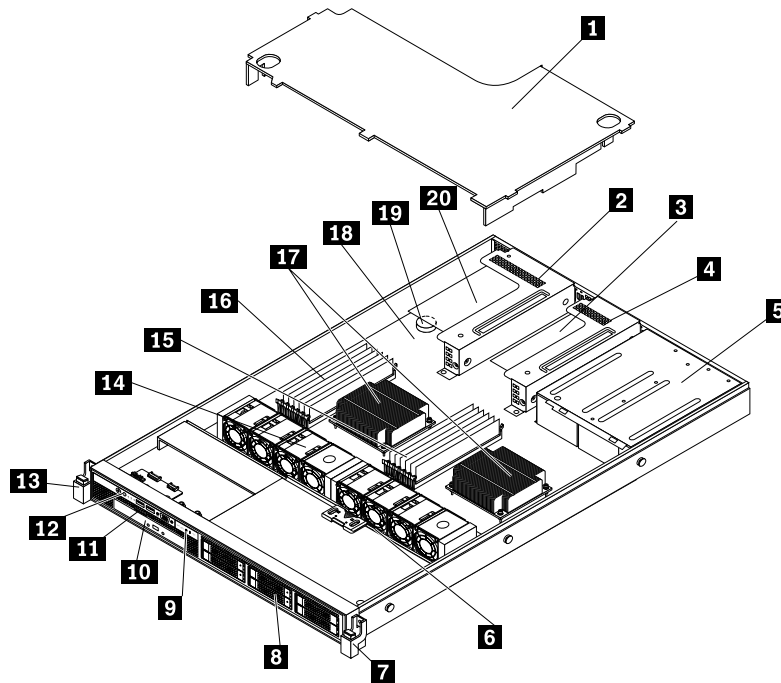

Figure 13. Components of server models with 2.5-inch hot-swap hard disk drives

1 Cooling shroud	11 Pull-out information card
2 Riser card assembly 1	12 Front panel
3 PCI Express card (available in some models)	13 Left rack handle
4 Riser card assembly 2	14 System fans
5 One or two hot-swap redundant power supplies	15 CPU2 DIMMs (vary by model)
6 Backplane for 2.5-inch hard disk drives	16 CPU1 DIMMs (vary by model)
7 Right rack handle	17 Heat sinks (vary by model)
8 2.5-inch hard disk drive bays	18 System board
9 Intelligent Diagnostics Module	19 System board battery
10 Slim optical drive (available in some models)	20 PCI Express card (available in some models)

Hot-swap hard disk drive status LEDs

Each hot-swap hard disk drive has two status LEDs on the front.

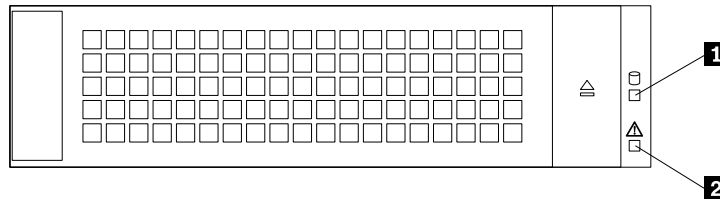

Figure 14. Hot-swap hard disk drive status LEDs

1 Hard disk drive activity LED	2 Hard disk drive RAID status LED	Description
Off	Off	The hard disk drive has failed or is not present.
On, green	Off	The hard disk drive is present but not in use.
Blinking, green	Off	The hard disk drive is active and data is being transferred.
On, green	Blinking rapidly (about four flashes per second), amber	The RAID controller is identifying the hard disk drive.
On, green	On, amber	The RAID array has failed and cannot be recovered. You need to recreate a new array.
Blinking, green	Blinking slowly (about one flash per second), amber	The hard disk drive is being rebuilt.

RAID card

This topic provides information to help you locate the connectors on a RAID card if you have one installed on the riser card assembly 2.

Some server models come with a RAID card to provide advanced SATA/SAS hardware RAID functions to the server. For more information, refer to “Installing or removing the RAID card” on page 85.

Note: The option kit for the RAID card is designed for different types of servers and might contain additional cables that are not required for your server.

Your server supports the following RAID cards:

- ThinkServer RAID 500 Adapter (also known as ThinkServer 9240-8i RAID 0/1 Adapter)
- ThinkServer RAID 700 Adapter (also known as ThinkServer 9260-8i SAS RAID Adapter)

ThinkServer RAID 500 Adapter (also known as ThinkServer 9240-8i RAID 0/1 Adapter)

The following illustration shows the connectors on the ThinkServer RAID 500 Adapter.

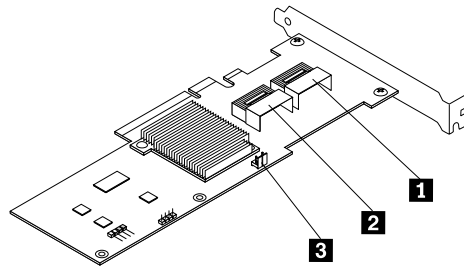

Figure 15. ThinkServer RAID 500 Adapter

1 Port 0	3 ThinkServer RAID 500 Upgrade Key for Advanced RAID connector
2 Port 1	

1 Port 0

Used to connect a mini-SAS signal cable. See “Mini-SAS to mini-SAS signal cable connections” on page 29.

2 Port 1

Used to connect a mini-SAS signal cable. See “Mini-SAS to mini-SAS signal cable connections” on page 29.

3 ThinkServer RAID 500 Upgrade Key for Advanced RAID connector

Used to connect a ThinkServer RAID 500 Upgrade Key for Advanced RAID. See “Installing or removing the ThinkServer RAID 500 Upgrade Key for Advanced RAID” on page 89.

ThinkServer RAID 700 Adapter (also known as ThinkServer 9260-8i SAS RAID Adapter)

The following illustration shows the connectors on the ThinkServer RAID 700 Adapter.

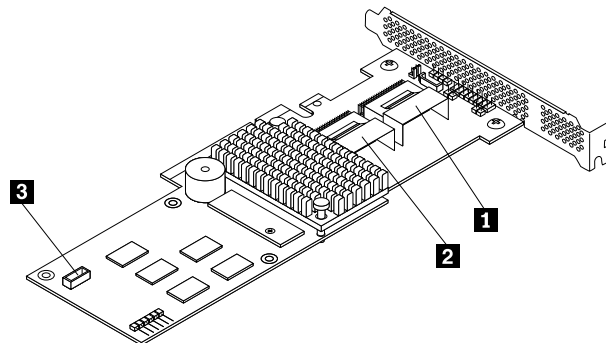

Figure 16. ThinkServer RAID 700 Adapter

1 Ports 7-4	3 ThinkServer RAID 700 Battery connector
2 Ports 3-0	

1 Ports 7-4

Used to connect a mini-SAS signal cable. See “Mini-SAS to mini-SAS signal cable connections” on page 29.

2 Ports 3-0

Used to connect a mini-SAS signal cable. See “Mini-SAS to mini-SAS signal cable connections” on page 29.

3 ThinkServer RAID 700 Battery connector

Used to connect a ThinkServer RAID 700 Battery. See “Installing or removing the ThinkServer RAID 700 Battery” on page 93.

Hot-swap hard disk drive backplane

Your server comes with one of the following hot-swap hard disk drive bay and backplane configurations:

- Up to four 3.5-inch hot-swap SATA or SAS hard disk drives with one backplane
- Up to six 2.5-inch hot-swap SAS hard disk drives or SATA solid-state drives with one backplane

To locate the backplane, see “Server components” on page 22.

Backplane for 3.5-inch hard disk drives

This topic provides information to help you locate the connectors on the backplane for 3.5-inch hard disk drives.

The following illustrations show the connectors on the backplane for 3.5-inch hard disk drives.

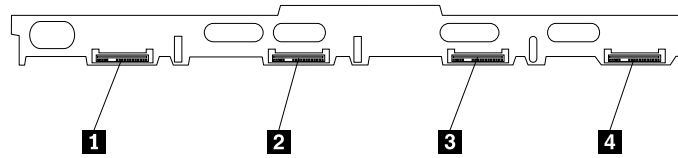

Figure 17. Front view of the backplane for 3.5-inch hard disk drives

1 Slot 0 for a 3.5-inch hard disk drive	3 Slot 2 for a 3.5-inch hard disk drive
2 Slot 1 for a 3.5-inch hard disk drive	4 Slot 3 for a 3.5-inch hard disk drive

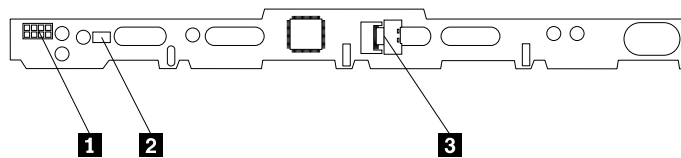

Figure 18. Rear view of the backplane for 3.5-inch hard disk drives

1 8-pin power connector	3 Mini-SAS ports 0-3
2 Optical drive power connector	

1 8-pin power connector

Used to connect a power cable to provide power to the backplane.

2 Optical drive power connector

Used to connect the power cable for the slim optical drive if the server has one installed.

3 Mini-SAS ports 0-3

Used to connect the mini-SAS connector on one end of a mini-SAS to mini-SAS signal cable to support the hard disk drive 0 to hard disk drive 3.

Backplane for 2.5-inch hard disk drives

This topic provides information to help you locate the connectors on the backplane for 2.5-inch hard disk drives.

The following illustrations show the connectors on the backplane for 2.5-inch hard disk drives.

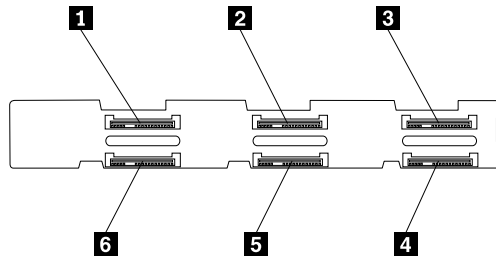

Figure 19. Front view of the backplane for 2.5-inch hard disk drives

1 Slot 0 for a 2.5-inch hard disk drive	4 Slot 5 for a 2.5-inch hard disk drive
2 Slot 2 for a 2.5-inch hard disk drive	5 Slot 3 for a 2.5-inch hard disk drive
3 Slot 4 for a 2.5-inch hard disk drive	6 Slot 1 for a 2.5-inch hard disk drive

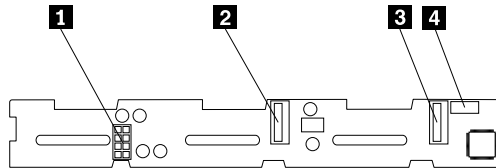

Figure 20. Rear view of the backplane for 2.5-inch hard disk drives

1 8-pin power connector	3 Mini-SAS ports 0-3
2 Mini-SAS ports 4-5	4 Optical drive power connector

1 8-pin power connector

Used to connect a power cable to provide power to the backplane.

2 Mini-SAS ports 4-5

Used to connect the mini-SAS connector on one end of a mini-SAS to mini-SAS signal cable to support the hard disk drive 4 to hard disk drive 5.

3 Mini-SAS ports 0-3

Used to connect the mini-SAS connector on one end of a mini-SAS to mini-SAS signal cable to support the hard disk drive 0 to hard disk drive 3.

4 Optical drive power connector

Used to connect the power cable for the slim optical drive if the server has one installed.

Mini-SAS to mini-SAS signal cable connections

This topic provides instructions on the following mini-SAS to mini-SAS signal cable connections:

- Connecting cables from the system board to the backplane

- Connecting cables from the RAID card to the backplane

Connecting cables from the system board to the backplane

To connect cables from the system board to the backplane, do the following:

1. Use one mini-SAS to mini-SAS signal cable. Connect one connector of the mini-SAS signal cable to the SAS connector 0-3 on the system board. Then, connect the other connector of the mini-SAS signal cable to the mini-SAS ports 0-3 on the hot-swap hard disk drive backplane.
2. If you have more than four hard disk drives installed, use the other mini-SAS to mini-SAS signal cable. Connect one connector of the mini-SAS signal cable to the SAS connector 4-7 on the system board. Then, connect the other connector of the mini-SAS signal cable to the mini-SAS ports 4-5 on the hot-swap hard disk drive backplane.

Note: If you connect the mini-SAS to mini-SAS signal cables from the system board to the backplane, you can configure RAID using the configuration utility for the ThinkServer RAID 300. See “Configuring the ThinkServer RAID 300” on page 58.

Connecting cables from the RAID card to the backplane

If your server has a supported RAID card installed, you can connect cables from the RAID card to the backplane to support up to six hard disk drives. In this case, you can configure RAID for the hard disk drives using the advanced hardware RAID functions.

Note: The option kit for the RAID card is designed for different types of servers and might contain additional cables that are not required for your server.

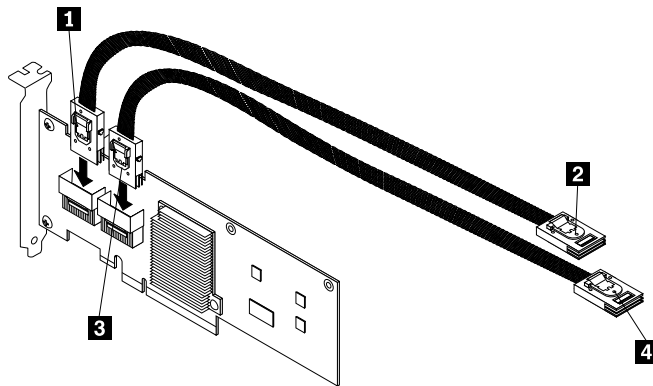

Figure 21. Connecting cables from the RAID card to the backplane

To connect cables from the RAID card to the backplane, do one of the following depending on the type of your RAID card:

- If you are using a ThinkServer RAID 700 Adapter, do the following:
 1. Use one mini-SAS to mini-SAS signal cable. Connect the mini-SAS connector **3** on one end of the cable to the ports 3-0 on the RAID card. Then, connect the mini-SAS connector **4** on the other end of the cable to the mini-SAS ports 0-3 on the backplane.
 2. If your server has more than four hard disk drives installed, use the other mini-SAS to mini-SAS signal cable. Connect the mini-SAS connector **1** on one end of the cable to the ports 7-4 on the RAID card. Then, connect the mini-SAS connector **2** on the other end of the cable to the mini-SAS ports 4-5 on the backplane.
- If you are using a ThinkServer RAID 500 Adapter, do the following:

1. Use one mini-SAS to mini-SAS signal cable. Connect the mini-SAS connector **1** on one end of the cable to the port 0 on the RAID card. Then, connect the mini-SAS connector **2** on the other end of the cable to the mini-SAS ports 0-3 on the backplane.
2. If your server has more than four hard disk drives installed, use the other mini-SAS to mini-SAS signal cable. Connect the mini-SAS connector **3** on one end of the cable to the port 1 on the RAID card. Then, connect the mini-SAS connector **4** on the other end of the cable to the mini-SAS ports 4-5 on the backplane.

Refer to the following topics for information about the connector locations:

- “Hot-swap hard disk drive backplane” on page 27
- “RAID card” on page 25
- “System board components” on page 31

System board components

The following illustration shows the component locations on the system board.

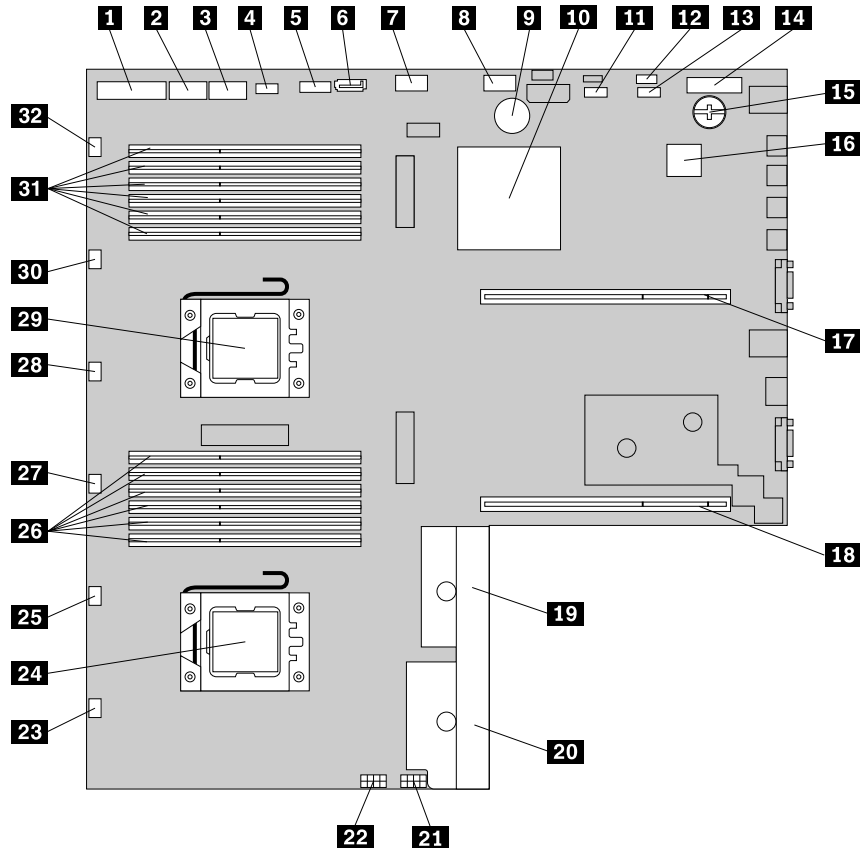

Figure 22. System board components

1 Front panel connector	17 Riser card assembly 1 slot
2 Internal USB connector 1	18 Riser card assembly 2 slot
3 Internal USB connector 2	19 Redundant power supply connector 1
4 Intelligent Diagnostics Module connector	20 Redundant power supply connector 2

5 Front VGA connector	21 Backplane power connector 1
6 SATA connector 0	22 Backplane power connector 2
7 SAS connector 4-7	23 System fan 7 connector
8 SAS connector 0-3	24 Microprocessor socket 2
9 System board battery	25 System fan 6 connector
10 Platform Controller Hub (PCH)	26 Memory slots (6)
11 Internal USB Type A connector 1	27 System fan 5 connector
12 TMM Premium connector	28 System fan 3 connector
13 Internal USB Type A connector 2	29 Microprocessor socket 1
14 TPM connector	30 System fan 2 connector
15 iButton socket	31 Memory slots (6)
16 ThinkServer Management Module	32 System fan 1 connector

1 Front panel connector

Used to connect the front panel cable.

2 Internal USB connector 1

Used to connect the front panel USB cable.

3 Internal USB connector 2

Reserved for the manufacturer.

4 Intelligent Diagnostics Module connector

Used to connect the cable of the Intelligent Diagnostics Module.

5 Front VGA connector

Used to connect the cable of the front VGA connector on the front panel of the server.

6 SATA connector 0

Used to connect the signal cable of the slim optical drive if the server has one installed.

7 SAS connector 4-7

Used to connect the mini-SAS connector on one end of a mini-SAS to mini-SAS signal cable to support the hard disk drive 4 to hard disk drive 5.

8 SAS connector 0-3

Used to connect the mini-SAS connector on one end of a mini-SAS to mini-SAS signal cable to support the hard disk drive 0 to hard disk drive 3.

9 System board battery

Your server has a special type of memory that maintains the date, time, and configuration information for built-in features. The system board battery keeps the information active when you turn off the server.

10 Platform Controller Hub (PCH)

This chip on the system board serves as a PCH, which provides the data buffering and interface arbitration required to ensure that system interfaces operate efficiently and provides the bandwidth necessary for the system to achieve peak performance. The chip supports and provides many features, including the onboard SAS software RAID.

11 Internal USB Type A connector 1

13 Internal USB Type A connector 2

Used to connect a device that uses a USB Type A connector. For example, in some situations, you might want to connect a USB key directly to the system board. In this case, you can connect it to an internal USB Type A connector.

12 TMM Premium connector

Used to connect a server option named ThinkServer Management Module Premium (TMM Premium) to enable advanced remote management functions on your server. See “Installing or removing the ThinkServer Management Module Premium” on page 100.

14 TPM connector

Used to connect a ThinkServer Trusted Platform Module (TPM), which is a security chip, to enhance server security. See “Installing or removing the ThinkServer Trusted Platform Module” on page 103.

15 iButton socket

Your server supports ThinkServer RAID 300, which includes onboard SAS software RAID levels 0, 1, and 10. You also can activate onboard SAS software RAID 5 by installing a ThinkServer RAID 300 Upgrade Key for Advanced RAID in the iButton socket. For more information, see “Installing or removing the ThinkServer RAID 300 Upgrade Key for Advanced RAID” on page 96.

16 ThinkServer Management Module

With the integrated ThinkServer Management Module (hereinafter referred to as the TMM), no matter what condition the server operating system is in and no matter if the server is on or off, as long as the server is connected to network and an ac power source, the interaction with the TMM controlled servers can be achieved through system network. The user can obtain the server hardware health information and SEL, and is able to conduct the operations including turning on or off the server, restarting the server, locking the power switch on the front panel, and so on. This part of the server management is independent of the operating system and is called out-of-band management.

17 Riser card assembly 1 slot

Used to install the riser card assembly 1.

18 Riser card assembly 2 slot

Used to install the riser card assembly 2.

19 Redundant power supply connector 1

20 Redundant power supply connector 2

Used to connect a hot-swap redundant power supply.

21 Backplane power connector 1

Used to connect the power cable from the backplane.

22 Backplane power connector 2

Reserved for the manufacturer.

23 25 27 28 30 32 System fan connectors

Used to connect the cable of the corresponding system fan.

26 31 Memory slots

There are 12 memory slots on the system board. For more information, see “Memory module installation rules” on page 75.

24 Microprocessor socket 2

29 Microprocessor socket 1

If the server has two microprocessors, each of the microprocessor is secured in the microprocessor socket on the system board and a heat sink is installed above the microprocessor to provide cooling. If the server has only one microprocessor, the microprocessor socket 2 is protected by a microprocessor socket cover.

System board jumpers and switches

This topic provides information about the jumpers and switches on the system board.

A jumper is a short length of conductor used to set up or adjust printed circuit boards, such as the system board of a computer. A jumper usually is encased in a non-conductive block of plastic for convenient use and to avoid any possible damage to a live circuit. Jumper pins arranged in groups on the system board are called jumper blocks. When two or more jumper pins are capped with a jumper, an electrical connection is made between them and the equipment is thus instructed to activate certain settings accordingly.

The following illustration shows a jumper in the default setting position (pin 1 and pin 2). This is the correct position for normal operation.

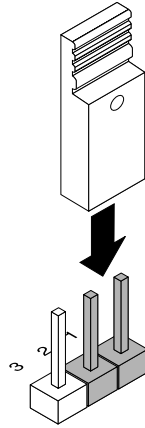

Figure 23. Default jumper setting

The following illustration shows the status of the jumpers and switches on the system board of your server. You can configure, recover, enable, or disable some specific features of the system board by setting the jumpers or moving the switches.

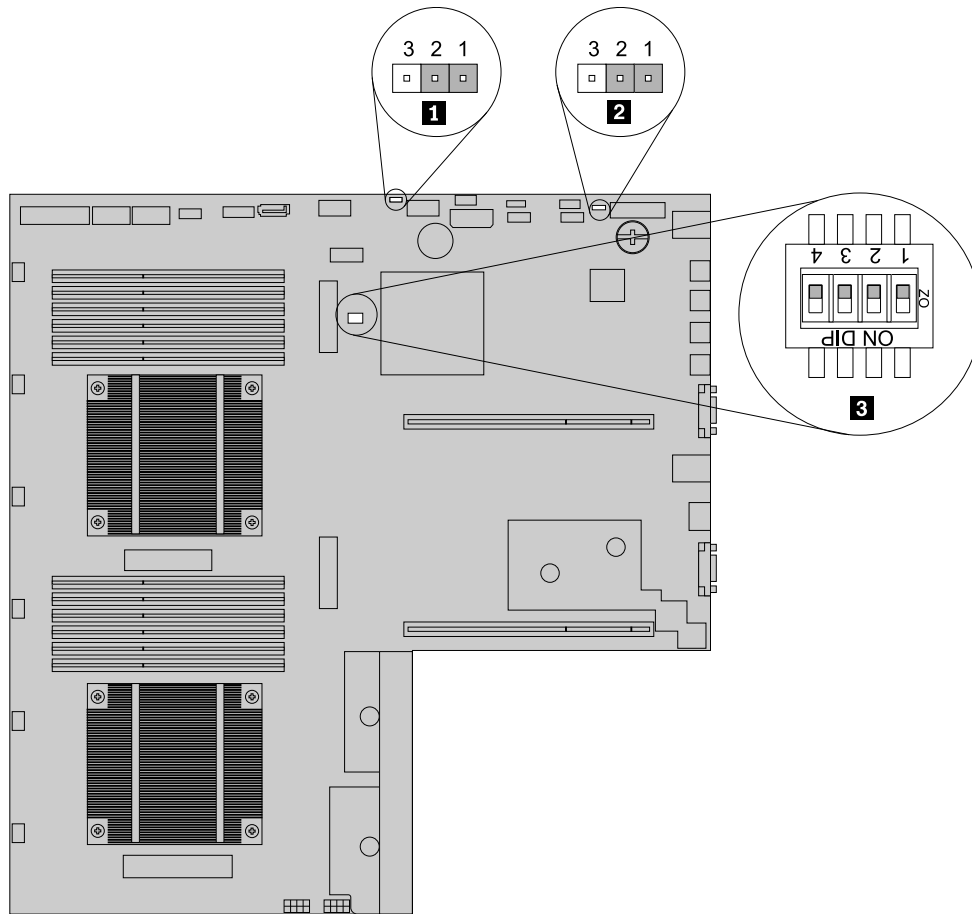

Figure 24. System board jumpers and switches

Table 1. System jumpers

1 Clear CMOS (Complementary Metal Oxide Semiconductor) jumper	3 Switches
2 ThinkServer Management Module Enable/Disable jumper	

Attention: To set the jumpers or move switches, you need to remove the server cover to access the system board. Do not open your server or attempt any repair before reading and understanding “Safety information” on page iii and “Guidelines” on page 67.

1 Clear CMOS jumper

Used to clear CMOS and recover your server to the factory default settings.

Note: After clearing CMOS, your BIOS recovers to the factory default settings.

To clear CMOS, do the following:

1. Remove all media from the drives and turn off all attached devices and the server. Then, disconnect all power cords from electrical outlets and disconnect all cables that are connected to the server.
2. If the server is installed in a rack cabinet, remove the server from the rack cabinet and place it on a flat, clean, and static-protective surface. See the *Rack Installation Instructions* that comes with the server.
3. Remove the server cover. See “Removing the server cover” on page 69.
4. Locate the Clear CMOS jumper on the system board. Then, remove any parts and disconnect any cables that might impede your access to the jumper.
5. Move the clear CMOS jumper from the default normal position (pin 1 and pin 2) to the short-circuited position (pin 2 and pin 3).
6. Wait more than five seconds and then move the Clear CMOS jumper back to the normal position (pin 1 and pin 2).
7. Reinstall any parts and reconnect any cables. Then, reinstall the server cover. See “Completing the parts replacement” on page 147.
8. Connect the server to an ac power source and wait about 30 seconds. Then, turn on the server. The BIOS recovers to the factory default settings.

2 ThinkServer Management Module Enable/Disable jumper

When the ThinkServer Management Module Enable/Disable jumper (hereinafter referred to as the TMM Enable/Disable jumper) is in the default normal position (pin 1 and pin 2), the server needs about 30 seconds for the TMM to initialize whenever you connect the server to an ac power source. If you press the power switch on the front panel during this period, the server will not start immediately; it will start after the TMM initialization finishes. The TMM function is available in this situation.

If you move the TMM Enable/Disable jumper to pin 2 and pin 3, the TMM function is not available and the server will be directly turned on when you press the power switch without waiting for the TMM to be ready.

3 Switches

There are four switches on the system board of your server.

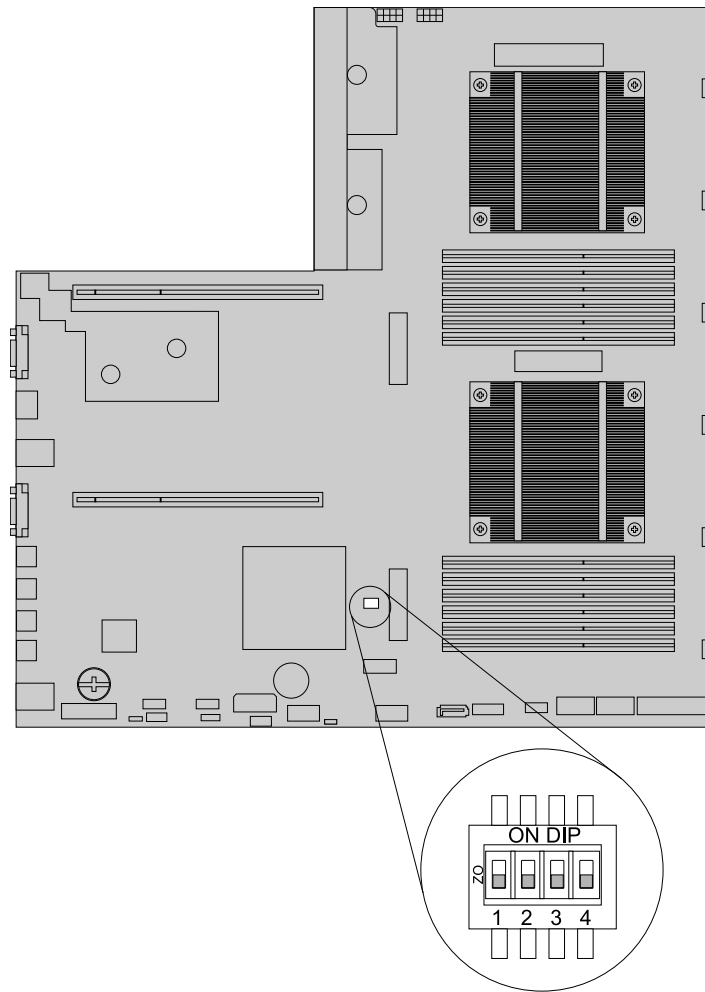

Figure 25. Switches

Table 2. Switches

1 BIOS recovery switch	3 Management Engine (ME) in force update switch
2 Clear password switch	4 Reserved for the manufacturer

1 BIOS recovery switch

Used to recover the BIOS if the power to your server is interrupted while the BIOS is being updated and your server cannot start correctly.

To recover the BIOS, see “Recovering from a BIOS update failure” on page 52.

2 Clear password switch

Used to erase forgotten passwords, such as the BIOS passwords.

To clear passwords, do the following:

1. Remove all media from the drives and turn off all attached devices and the server. Then, disconnect all power cords from electrical outlets and disconnect all cables that are connected to the server.
2. If the server is installed in a rack cabinet, remove the server from the rack cabinet and place it on a flat, clean, and static-protective surface. See the *Rack Installation Instructions* that comes with the server.
3. Remove the server cover. See “Removing the server cover” on page 69.
4. Locate the Clear password switch on the system board. Then, remove any parts and disconnect any cables that might impede your access to the switch.
5. Move the clear password switch from the default off position to the on position.
6. Wait more than five seconds and then move the clear password switch back to the off position.
7. Reinstall any parts and reconnect any cables. Then, reinstall the server cover. See “Completing the parts replacement” on page 147.
8. Connect the server to an ac power source and wait about 30 seconds. Then, turn on the server. The BIOS passwords are erased, including the administrator password and user password.
9. To set new passwords, see “Using passwords” on page 49.

3 ME in force update switch

Used to update (flash) the ME.

The ME updating process usually is contained in the BIOS updating (flashing) process.

Note: Only some BIOS versions contain the parameters for updating the ME. If you want to update the ME, ensure that your BIOS version contains the required parameters.

To update the ME, do the following:

1. Remove all media from the drives and turn off all attached devices and the server. Then, disconnect all power cords from electrical outlets and disconnect all cables that are connected to the server.
2. If the server is installed in a rack cabinet, remove the server from the rack cabinet and place it on a flat, clean, and static-protective surface. See the *Rack Installation Instructions* that comes with the server.
3. Remove the server cover. See “Removing the server cover” on page 69.
4. Locate the ME in force update switch on the system board. Then, remove any parts and disconnect any cables that might impede your access to the switch.
5. Move the ME in force update switch from the default off position to the on position.
6. Reinstall any parts and reconnect any cables. Then, reinstall the server cover. See “Completing the parts replacement” on page 147.
7. Connect the server to an ac power source. Then, update the BIOS. See “Updating (flashing) the BIOS” on page 52.
8. Repeat step 1 through step 4.
9. Move the ME in force update switch back to the off position.
10. Reinstall any parts and reconnect any cables. Then, reinstall the server cover. See “Completing the parts replacement” on page 147.
11. Connect the server to an ac power source and turn on the server. The BIOS and ME have been updated. You need to check and configure the BIOS settings for your specific needs. See “Using the Setup Utility program” on page 45.

System board LEDs

This topic helps you locate the LEDs on the system board.

Note: Depending on the model, your server might look slightly different from the illustration in this topic.

The server is designed so that LEDs remain lit when the server is connected to an ac power source but is not turned on, provided that the power supply is operating correctly. This helps you isolate problems when the server is not turned on. Many errors are first indicated by a lit error LED on the diagnostic panel of the server. If an LED is lit, one or more LEDs elsewhere in the server might also be lit to direct you to the source of the error.

The following illustration shows the ThinkServer Management Module status LED and system fan error LEDs on the system board.

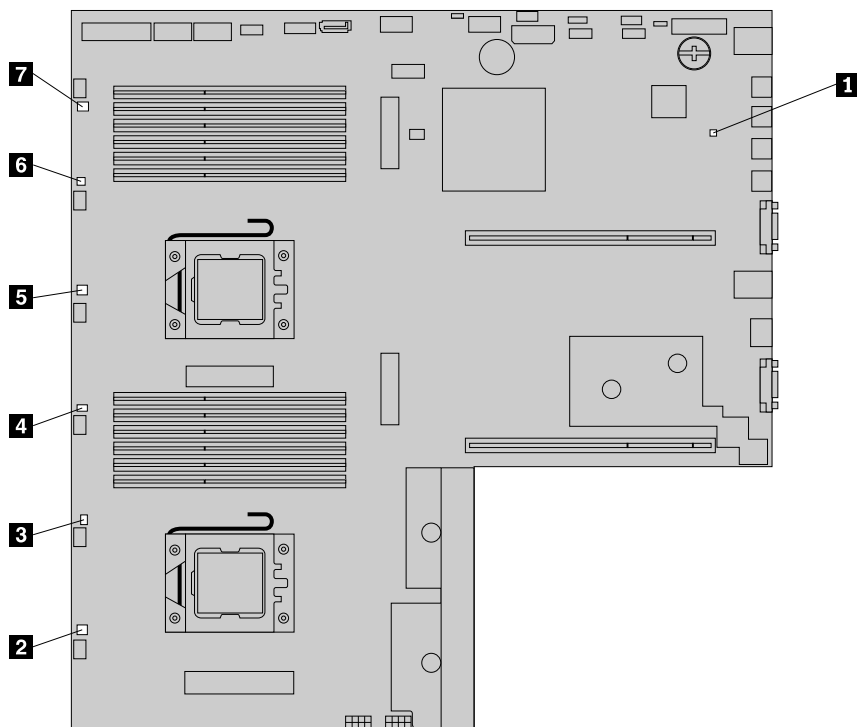

Figure 26. System board LEDs

1 ThinkServer Management Module status LED	5 System fan 3 error LED
2 System fan 7 error LED	6 System fan 2 error LED
3 System fan 6 error LED	7 System fan 1 error LED
4 System fan 5 error LED	

1 ThinkServer Management Module status LED

This LED indicates the status of the onboard ThinkServer Management Module (TMM).

ThinkServer Management Module status LED	Color	Description
On	Green	The TMM is not ready.
Off	None	The TMM has no power or has failed.
Blinking	Green	The TMM is working.

2 - 7 System fan error LEDs

When a system fan error LED on the system board is lit, it indicates that the corresponding system fan is operating slowly or has failed. To solve the problem, you might need to reinstall or replace the system fan. See “Replacing a system fan” on page 139. If it is a system board problem, contact the Lenovo Customer Support Center.

Chapter 4. Turning on and turning off the server

This chapter provides information about turning on and turning off the server.

Turning on the server

The server can be turned on in one of the following ways:

- After you finish unpacking and setting up the server, connect it to an ac power source. Press the power switch on the front panel to turn on the server. See “Front panel” on page 17. The server needs about 30 seconds for the TMM to initialize whenever you connect the server to an ac power source. If you press the power switch on the front panel during this period, the server will not start immediately; it will start after the TMM initialization finishes.
 - When the Wake on LAN feature is enabled on the server that is connected to an ac power source and a LAN, a network administrator can remotely turn on or wake up the server from a management console using remote network management software.
 - You also can use the related TMM feature to remotely turn on the server through the management LAN. For more information about the TMM, refer to the *ThinkServer Management Module User Guide*, which is available for download at:
<http://www.lenovo.com/ThinkServerUserGuides>
-

Turning off the server

CAUTION:

The power control button on the device and the power switch on the power supply do not turn off the electrical current supplied to the device. The device also might have more than one power cord. To remove all electrical current from the device, ensure that all power cords are disconnected from the power source.

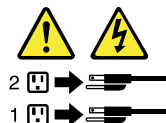

The server can be turned off in one of the following ways:

- Turn off the server from the operating system if your operating system supports this feature. After an orderly shutdown of the operating system, the server will turn off automatically. For instructions on how to shut down your specific operating system, refer to the related documentation or help system for the operating system.
- Press the power switch on the front panel to start an orderly shutdown of the operating system and turn off the server, if your operating system supports this feature.
- If your server stops responding and you cannot turn it off, press and hold the power switch on the front panel for four seconds or more. If you still cannot turn off the server, disconnect all power cords from the server.
- If the server is connected to a LAN, a network administrator can remotely turn off the server from a management console using remote network management software.
- You also can use the related TMM feature to remotely turn off the server through the management LAN. For more information about the TMM, refer to the *ThinkServer Management Module User Guide*, which is available for download at:
<http://www.lenovo.com/ThinkServerUserGuides>

- The server might be turned off as an automatic response to a critical system failure.

Notes:

- When you turn off the server and leave it connected to an ac power source, the server also can respond to a remote request to turn on the server. To remove all power from the server, you must disconnect the server from the ac power source.
- For information about your specific operating system, refer to the related documentation or help system for the operating system.

Chapter 5. Configuring the server

This chapter provides the following information to help you configure the server:

- “Using the Setup Utility program” on page 45
- “Using the ThinkServer EasyStartup program” on page 53
- “Configuring RAID” on page 56
- “Configuring the Ethernet controllers” on page 64
- “Updating the firmware” on page 64
- “Using the Lenovo ThinkServer EasyManage program” on page 65

Using the Setup Utility program

This topic provides information about using the Setup Utility program.

The Setup Utility program is part of the server firmware. You can use the Setup Utility program to view and change the configuration settings of your server, regardless of which operating system you are using. However, the operating system settings might override any similar settings in the Setup Utility program.

Starting the Setup Utility program

This topic provides instructions on how to start the Setup Utility program.

To start the Setup Utility program, do the following:

1. Connect the server to an ac power source and press the power switch on the front panel to turn on the server. See “Turning on the server” on page 43.
2. Press the F1 key as soon as you see the logo screen. Then, wait for several seconds, and the Setup Utility program opens. If you have set a password, you need to type the correct password to enter the Setup Utility program. For password information, see “Using passwords” on page 49.

Viewing information in the Setup Utility program

The Setup Utility program menu lists various items about the system configuration. Select a desired item to view information or change settings.

When working with the Setup Utility program, you must use the keyboard. The keys used to perform various tasks are displayed on the right bottom pane of each screen. You also can press the F1 key for general help about the keys. For most items, the corresponding help message is displayed on the right top pane of the screen when the item is selected. If the item has submenus, you can display the submenus by pressing Enter.

You can view the following information about your specific server model in the Setup Utility program:

- The **Main** menu lists information about the BIOS and BMC, total memory size, and system date and time.
- On the **Advanced** menu:
 - Select **Processor Configuration** and follow the instructions on the screen to view information about the installed microprocessor and its supported technologies.
 - Select **Memory Configuration** and follow the instructions on the screen to view information about the installed memory modules.

- Select **SATA/SAS Configuration** and follow the instructions on the screen to view information about the installed SATA or SAS devices, such as a hard disk drive or an optical drive.
- On the **Server Management** menu, select **System Information** to view information about your system.

Setup Utility program interface

This topic provides general information about the menus and items in the Setup Utility program.

Depending on the BIOS version of your server, some menu or item information might differ slightly from the information in this topic.

Notes:

- The default settings already are optimized for you. Use the default value for any item you are not familiar with. Do not change the value of unfamiliar items to avoid unexpected problems. If you consider changing the server configuration, proceed with extreme caution. Setting the configuration incorrectly might cause unexpected results. If you cannot turn on the server because of incorrect BIOS settings, use the Clear CMOS jumper to restore the BIOS settings to the factory default settings. See “System board jumpers and switches” on page 34.
- If you have changed any hardware in the server, you might need to reflash the BIOS, the BMC firmware, and the FRU/Sensor Data Records (SDR).

The Setup Utility program main interface consists of the following menus:

- “Main menu” on page 46
- “Advanced menu” on page 46
- “Security menu” on page 47
- “Server Management menu” on page 47
- “Boot Options menu” on page 48
- “Boot Manager menu” on page 48
- “Save & Exit menu” on page 48

Lenovo provides the BIOS update utility on the Lenovo Support Web site. You can download the BIOS update utility to update the BIOS if the newer BIOS version specifically solves a problem you have. See “Updating or recovering the BIOS” on page 51.

If the power to your server is interrupted while the BIOS is being updated and your server cannot start correctly, use the BIOS recovery switch to recover from a BIOS update failure. See “System board jumpers and switches” on page 34.

Main menu

After entering the Setup Utility program, you can see the **Main** menu, which lists basic information about the BIOS and BMC, total memory size, and system date and time.

To set the system date and time on the **Main** menu, see “Setting the system date and time” on page 48.

Advanced menu

You can view or change various server component settings on the **Advanced** menu in the Setup Utility program. The **Advanced** menu contains various configuration submenus and items. On each submenu, press Enter to show selectable options and select a desired option by using the up and down arrow keys or type desired values from the keyboard. Some items are displayed on the menu only if the server supports the corresponding features.

Notes:

- **Enabled** means that the function is configured.
- **Disabled** means that the function is not configured.

The **Advanced** menu contains the following submenus. For more information, enter the corresponding submenu and refer to the instructions on the screen.

- **PCI Configuration:** View and set PCI configuration parameters.
- **ACPI Configuration:** View and set ACPI configuration parameters.
- **Processor Configuration:** View information about the installed microprocessor(s) and set microprocessor configuration parameters.
- **Memory Configuration:** View information about the installed memory modules and set memory configuration parameters.
- **Chipset Configuration:** View and set chipset configuration parameters.
- **SATA/SAS Configuration:** View information about the installed SATA or SAS devices and set SATA or SAS configuration parameters.
- **USB Configuration:** View and set USB configuration parameters, such as enabling or disabling USB devices.
- **Super IO Configuration:** View and set serial port configuration parameters.
- **Serial Port Console Redirection:** View and set configuration parameters for the serial port console redirection.

Security menu

You can set passwords and configure the TPM function on the **Security** menu in the Setup Utility program. For each menu item, press Enter to show selectable options and select a desired option by using the up and down arrow keys or type desired values from the keyboard. Some items are displayed on the menu only if the server supports the corresponding features.

Notes:

- **Enabled** means that the function is configured.
- **Disabled** means that the function is not configured.

The **Security** menu contains the following items:

- **Administrator Password:** Set an administrator password to protect against unauthorized access to your server. See “Using passwords” on page 49.
- **User Password:** Set a user password to protect against unauthorized access to your server. See “Using passwords” on page 49.
- **TPM/TCM:** Configure the TPM function if your server has a TPM installed in the TPM connector on the system board. See “Configuring the TPM function” on page 50.

Server Management menu

You can view system information and view or change event log and BMC settings on the **Server Management** menu in the Setup Utility program. On each submenu, press Enter to view the information or show selectable options and select a desired option by using the up and down arrow keys. Some items are displayed on the menu only if the server supports the corresponding features.

The **Server Management** menu contains the following submenus. For more information, enter the corresponding submenu and refer to the instructions on the screen.

- **Erase SEL:** Erase system event log (SEL).

- **System Information:** View basic information about your server.
- **BMC Network Configuration:** Set BMC configuration parameters.

Boot Options menu

The **Boot Options** menu in the Setup Utility program provides an interface to help you view or change the server startup options, including the startup sequence and boot priority for various devices. Changes in the startup options take effect when the server starts.

The startup sequence specifies the order in which the server checks devices to find a boot record. The server starts from the first boot record that it finds. For example, you can define a startup sequence that checks a disc in the optical drive, then checks the hard disk drive, and then checks a network device. For information about setting the startup sequence or selecting a startup device, see “Selecting a startup device” on page 50.

Boot Manager menu

The **Boot Manager** menu in the Setup Utility program lists all the bootable devices installed in your server and the listed items vary depending on your server configuration. If you select a desired device listed on this menu, the server will start from the device you select.

You can press F12 when turning on the server and select a temporary startup device from the boot device selection window. See “Selecting a startup device” on page 50.

Save & Exit menu

After you finish viewing or changing settings in the Setup Utility program, you can choose a desired action from the **Save & Exit** menu to save changes, discard changes, or load default values, and exit the program. Press Enter to select the item on the **Save & Exit** menu and then select **Yes** when prompted to confirm the action. For information about exiting the Setup Utility program, see “Exiting the Setup Utility program” on page 51.

The **Save & Exit** menu contains the following items:

- **Save Changes and Exit:** Save changes and exit the Setup Utility program.
- **Save Changes and Reset:** Save changes and then continue with the configuration in the Setup Utility program.
- **Discard Changes and Exit:** Discard changes, load previous values, and then exit the Setup Utility program.
- **Discard Changes:** Discard changes and load previous values.
- **Restore Defaults:** Return to the optimized default settings.
- **Save as User Defaults:** Save the current settings as user default values.
- **Restore User Defaults:** Restore the user default values for all the items.

Setting the system date and time

This topic provides instructions on how to set the system date and time in the Setup Utility program.

To set the system date and time in the Setup Utility program, do the following:

1. Start the Setup Utility program. See “Starting the Setup Utility program” on page 45.
2. On the **Main** menu, select **System Date** or **System Time**.
3. Use the Tab key to switch between data elements and type the numbers from the keyboard to set the system date and time.
4. Press F10 to save settings and exit the Setup Utility program.

Using passwords

By using the Setup Utility program, you can set a password to prevent unauthorized access to your server.

You do not have to set a password to use your server. However, using a password improves computing security. If you decide to set a password, read the following topics.

Setup Utility program password types

The following types of passwords are available in the Setup Utility program:

- **Administrator password**

Setting an administrator password deters unauthorized users from changing configuration settings. If you are responsible for maintaining the configuration settings of several computers, you might want to set an administrator password. When an administrator password is set, you are prompted to type a valid password each time you try to access the Setup Utility program. The Setup Utility program cannot be accessed until a valid password is typed in.

- **User password**

When a user password is set, the server cannot be used until a valid password is typed in.

Note: If both the administrator password and user password are set, you can type either password to use the server. However, you must use your administrator password to change any configuration settings.

Password considerations

For security reasons, it is recommended to use a strong password that cannot be easily compromised.

Notes:

- The Setup Utility program passwords are not case sensitive.
- The server supports Setup Utility program passwords that consist of three to 20 characters.

To set a strong password, use the following guidelines:

- Have at least eight characters in length
- Contain at least one alphabetic character and one numeric character
- Not be your name or your user name
- Not be a common word or a common name
- Be significantly different from your previous passwords

Besides the alphabetic characters (a-z) and numeric characters (0-9), the server also supports characters typed using special keys on the keyboard for a password. Refer to the help message on the screen when setting a password to determine the valid special characters.

Setting, changing, or deleting a password

This topic provides instructions on how to set, change, or delete a password in the Setup Utility program.

To set, change, or delete a password in the Setup Utility program, do the following:

1. Start the Setup Utility program. See “Starting the Setup Utility program” on page 45.
2. On the **Security** menu, select **Administrator Password** to set an administrator password or select **User Password** to set a user password.
3. See “Password considerations” on page 49. Then, follow the instructions on the screen to set or change a password.

4. If you want to delete a password, type your current password. Press Enter when you are prompted to type a new password. Then, press Enter to confirm the new password. The previous password will be cleared.

Note: For security reasons, it is recommended that you always set a password for your server.

5. Press F10 to save settings and exit the Setup Utility program.

If you have forgotten the password, you can use the Clear password switch on the system board to erase the password. See “System board jumpers and switches” on page 34. Then, set a new password for the server.

Selecting a startup device

If your server does not start up from a desired device such as the disc or hard disk drive as expected, do one of the following to select the startup device you want.

Note: Not all discs, hard disk drives, or other removable devices are bootable.

- To select a temporary startup device, do the following:

Note: Selecting a startup device using the following method does not permanently change the startup sequence.

1. Turn on or restart your server.
 2. When you see the logo screen, press F10 if your server is connected to a network and you want to start up the server from the network. Otherwise, press F12 to display the boot menu. The boot device selection window opens.
 3. In the boot device selection window, use the up and down arrow keys on the keyboard to switch between the selections. Press Enter to select the device of your choice. Then, the server will start up from the selected device.
- To view or permanently change the configured startup device sequence, do the following:
 1. Start the Setup Utility program. See “Starting the Setup Utility program” on page 45.
 2. On the **Boot Options** menu, follow the instructions on the screen to set the startup device for **Boot Option #1** to **Boot Option #5** depending on your needs. You also can set the boot priority for various devices. See “Boot Options menu” on page 48.
 3. Press F10 to save settings and exit the Setup Utility program. The server will follow the startup device sequence you have set each time you turn on the server.

Configuring the TPM function

The TPM works as a hardware security solution to help you to encrypt data and protect the server. The TPM function is only available when there is a TPM installed in your server. See “Installing the ThinkServer Trusted Platform Module” on page 103. You can purchase a TPM from Lenovo.

After installing a TPM, you need to check if the TPM function is enabled in the Setup Utility program.

To enable the TPM function in the Setup Utility program, do the following:

1. Start the Setup Utility program. See “Starting the Setup Utility program” on page 45.
2. On the **Security** menu, select **TPM/TCM → TPM Support**. Ensure that **TPM Support** is set to **Enabled**.
3. When **TPM Support** is set to **Enabled**, the **TPM State** item is displayed. Set **TPM State** to **Enabled**.
4. Press F10 to save settings and exit the Setup Utility program. The server will restart to enable the TPM function.

Setting the mode of the Ethernet connector 0

The Ethernet connector 0 on the rear of the server is for system management. If you want to use remote management functions, you need to connect an Ethernet cable to the Ethernet connector 0. See “Rear view of the server” on page 20.

The Ethernet connector 0 for system management is 82574L by default. If you have selected share mode for the 82574L Ethernet connector in the Setup Utility program, you can use the connector as an ordinary Ethernet connector with 100 Mbps network connectivity. However, teaming with other Ethernet connectors is not supported if the management Ethernet connector is used as an ordinary Ethernet connector.

To set the mode of the Ethernet connector 0 in the Setup Utility program, do the following:

1. Start the Setup Utility program. See “Starting the Setup Utility program” on page 45.
2. On the **Server Management** menu, select **BMC Network Configuration → BMC LAN Share Setting**.
3. Do one of the following:
 - If you want to use the Ethernet connector 0 as an ordinary Ethernet connector, select **Shared**.
 - If you want to use the Ethernet connector 0 as a dedicated system management Ethernet connector, select **Dedicated**.
4. Press F10 to save settings and exit the Setup Utility program.

Exiting the Setup Utility program

After you finish viewing or changing settings, press Esc to return to the Setup Utility program main interface. If you are on a nested submenu, press Esc repeatedly until you reach the main interface. Then, you can do one of the following to exit the Setup Utility program:

- If you want to save the new settings and exit the Setup Utility program, press F10 or select **Save & Exit → Save Changes and Exit**. Otherwise, your changes will not be saved.
- If you do not want to save the new settings, select **Save & Exit → Discard Changes and Exit**.
- If you want to return to the default settings, press F9 or select **Save & Exit → Restore Defaults**.

For more information about the **Save & Exit** menu in the Setup Utility program, see “Save & Exit menu” on page 48.

Updating or recovering the BIOS

This topic provides instructions on how to update the BIOS and how to recover from a POST and BIOS update failure.

System programs are the basic layer of software built into your server. System programs include the POST, the UEFI BIOS, the Setup Utility program, and the TMM firmware. The POST is a set of tests and procedures that are performed each time you turn on your server. The UEFI BIOS is a layer of software that translates instructions from other layers of software into electrical signals that the server hardware can execute. You can use the Setup Utility program to view or change the configuration settings of your server. See “Using the Setup Utility program” on page 45. The TMM firmware provides remote management features.

Lenovo might make changes and enhancements to the BIOS and TMM firmware. When updates are released, they are available for download on the Lenovo Web site at <http://www.lenovo.com/drivers>. You can update the server firmware by downloading an update package and following the instructions on the Web page.

You also can use the Firmware Updater program to help you keep the server firmware up-to-date. See “Updating the firmware” on page 64.

Updating (flashing) the BIOS

This topic provides instructions on how to update (flash) the BIOS.

Notes:

- Update the BIOS on your server only if the newer BIOS version specifically solves a problem you have. We do not recommend BIOS updates for servers that do not need them. You can view the updated information for the new BIOS version in the installation instructions for the BIOS update package.
- Downgrading the BIOS to an earlier version is not recommended and might not be supported. An earlier BIOS version might not support the latest system configurations.
- If the power to your server is interrupted while the POST and BIOS are being updated, your server might not restart correctly. Ensure that you perform the BIOS update procedure in an environment with a steady power supply. Besides, ensure that your server can restart successfully without encountering hardware problems.
- If you have updated the BIOS firmware, all the BIOS settings become the default settings of the updated BIOS version. You need to check and reconfigure the BIOS settings for your specific needs. You can select **Save as User Defaults** on the **Save & Exit** menu in the Setup Utility program to save your current BIOS settings as user default values before updating the BIOS. Then, you can select **Restore User Defaults** on the **Save & Exit** menu in the Setup Utility program to restore the user default values after updating the BIOS. In this case, you can keep your previous BIOS settings and do not need to reconfigure the settings after updating the BIOS. You also can note down your specific BIOS settings before updating the BIOS for an easier reconfiguration in the new BIOS version.

To update (flash) the BIOS, do the following:

1. Go to <http://www.lenovo.com/drivers> and follow the instructions on the Web page to locate the BIOS update package.
2. Download the BIOS update package and the installation instructions in a TXT file.
3. Print the TXT file that contains the installation instructions and follow the instructions to update (flash) the BIOS.
4. Do one of the following after the BIOS update process is completed:
 - If you have saved your BIOS settings as user default values before updating the BIOS, select **Restore User Defaults** on the **Save & Exit** menu in the Setup Utility program to restore the user default values. Then, check if the user default values meet your current requirements.
 - Check and reconfigure the BIOS settings for your specific needs based on your note or refer to “Using the Setup Utility program” on page 45.

Recovering from a BIOS update failure

If the power to your server is interrupted while the BIOS is being updated, your server might not restart correctly. If this happens, perform the following procedure to recover from the BIOS update failure.

Note: If the operating system of your server is installed under EFI mode, you need to reinstall the operating system after recovering the BIOS.

To recover from a BIOS update failure, do the following:

1. Go to <http://www.lenovo.com/drivers> and follow the instructions on the Web page to download a BIOS update package. Then, put the `amiboot.rom` file contained in the package into the root directory of a bootable USB key.
2. Remove all media from the drives and turn off all attached devices and the server. Then, disconnect all power cords from electrical outlets and disconnect all cables that are connected to the server.
3. If the server is installed in a rack cabinet, remove the server from the rack cabinet and place it on a flat, clean, and static-protective surface. See the *Rack Installation Instructions* that comes with the server.

4. Remove the server cover. See “Removing the server cover” on page 69.
5. Locate the BIOS recovery switch on the system board. See “System board jumpers and switches” on page 34. Then, remove any parts and disconnect any cables that might impede your access to the switch.
6. Move the BIOS recovery switch from the default off position to the on position.
7. Reinstall any parts and reconnect any cables. Then, reinstall the server cover. See “Completing the parts replacement” on page 147.
8. Connect the server to an ac power source and then start the server from the bootable USB key that contains the amiboot.rom file. The recovery process starts. After the recovery process is completed, your server will automatically turn off.
9. Repeat step 2 through step 5.
10. Move the BIOS recovery switch back to the off position.
11. Reinstall any parts and reconnect any cables. Then, reinstall the server cover. See “Completing the parts replacement” on page 147.
12. Connect the server to an ac power source and turn on the server. The BIOS settings recover to the factory default settings. You need to check and configure the BIOS settings for your specific needs. See “Using the Setup Utility program” on page 45.

Note: If you cannot recover the BIOS after using the instructions in this topic, the BIOS read-only memory (ROM) might be damaged and you need to replace the system board. Contact the Lenovo Customer Support Center.

Using the ThinkServer EasyStartup program

This topic guides you to use the ThinkServer EasyStartup program to set up and configure your server.

The ThinkServer EasyStartup program simplifies the process of configuring RAID and installing supported Windows and Linux operating systems and device drivers on your server. The program works in conjunction with your Windows or Linux operating system installation disc to automate the process of installing the operating system and associated device drivers. This program is provided with your server on a self-starting (bootable) *ThinkServer EasyStartup* DVD. The user guide for the program also is on the DVD and can be accessed directly from the program interface.

If you do not have a *ThinkServer EasyStartup* DVD, you also can download an ISO image from the Lenovo Support Web site and make a disc by yourself.

To download the ThinkServer EasyStartup program image and burn it into a disc, do the following:

1. Go to <http://www.lenovo.com/drivers> and follow the instructions on the Web page to locate the ThinkServer EasyStartup program.
2. Download the ISO image for the ThinkServer EasyStartup program and the readme file. The readme file contains important information about the ThinkServer EasyStartup program.
3. Print the readme file and read it carefully.
4. Use an optical drive and any DVD burning software to create a bootable disc with the ISO image.

Features of the ThinkServer EasyStartup program

This topic lists the features of the ThinkServer EasyStartup program.

The ThinkServer EasyStartup program has the following features:

- Contained in a self-starting (bootable) DVD

- Easy-to-use, language-selectable interface
- Integrated help system and user guide
- Automatic hardware detection
- Contains the RAID configuration utility
- Provides device drivers based on the server model and detected devices
- Downloads device drivers from the *ThinkServer EasyStartup* DVD according to the operating system or add-on device
- Selectable partition size and file system type
- Support for multiple operating systems
- Ability to install the operating system and device drivers in an unattended mode to save time
- Ability to create a reusable response file that can be used with similarly configured Lenovo servers to make future installations even faster

Starting the ThinkServer EasyStartup program

This topic provides instructions on how to start the ThinkServer EasyStartup program. After you start the program and enter the main interface, click **User Guide** for detailed information about how to use this program to help you configure the server and install an operating system.

To start the ThinkServer EasyStartup program, do the following:

1. Insert the *ThinkServer EasyStartup* DVD into an optical drive, set the optical drive as the first startup device, and start your server from the DVD in the optical drive. See “Selecting a startup device” on page 50.
2. Wait for the program to load. Then, you will be prompted for the following selections:
 - The language in which you want to view the program
 - The language of the keyboard layout you will be using with the program

Note: The supported languages and keyboard layouts for the ThinkServer EasyStartup program are Dutch, English, French, German, Italian, Japanese, Russian, Spanish, and Turkish. Your *ThinkServer EasyStartup* DVD might be English only. In this case, the keyboard layout should be English.

3. After selecting the language and keyboard layout, click **OK**. Then, you will see one or more reminders or messages about configuring storage devices. Click **Next** until you are presented with the Lenovo License Agreement. Read the Lenovo License Agreement carefully. In order to continue, you must accept the terms by clicking **Agree**. Then, the Date and time window opens.
4. Set the current date and time and click **OK**. The Start option window opens.
5. The Start option window provides the following selections:
 - Continue to the main interface.
 - Install the operating system using a pre-existing response file.
 - Configure RAID using a pre-existing response file.

Read the explanations on the screen and select a desired option. Then, follow the instructions on the screen. If this is the first time you are using the ThinkServer EasyStartup program, select the option to continue to the main interface and view the compatibility notes and user guide.

Notes:

- Functionality and supported operating systems vary depending on the version of the ThinkServer EasyStartup program. From the main interface of the program, click **Compatibility notes** to view the information about the RAID controllers, operating systems, and server configurations supported by the

specific version of the program; and click **User Guide** to view the various functions and learn how to use the program.

- Before using the ThinkServer EasyStartup program to install an operating system, ensure that any external storage devices and fiber channels are configured correctly.

The ThinkServer EasyStartup program main interface provides the following menus on the left pane of the screen:

- **Home**

This menu is the welcome page that contains some general descriptions about the program and the Lenovo copyright and trademark statements.

- **Compatibility notes**

This menu provides information about the RAID controllers, operating systems, and server configurations supported by the version of the program you are using.

- **User Guide**

This menu provides information about the features of the program and instructions on how to use the program.

- **Hardware list**

This menu displays a list of hardware devices detected by the program.

- **Configure RAID**

This menu guides you to configure RAID or view the current RAID configuration and make changes if needed.

- **Install operating system**

This menu displays a series of choices and prompts to collect information required for operating system installation, prepares the hard disk drive for installation, and then initiates the installation process using your operating system installation disc.

- **Download drivers**

This menu helps you download the required device drivers from the *ThinkServer EasyStartup* DVD to a removable storage device so that you can easily get the drivers for server configuration when you need them.

Note: The most up-to-date device drivers for various server models are always available for download on the Lenovo Support Web site at:

<http://www.lenovo.com/drivers>

- **About**

This menu provides the version information and legal notices.

Using the ThinkServer EasyStartup program on a Windows operating system

You can run the *ThinkServer EasyStartup* DVD on a Windows operating system with the Internet Explorer® 6.0 Web browser or a later version installed. Enter the operating system and insert the *ThinkServer EasyStartup* DVD into an internal or external optical drive. The DVD starts automatically in most environments. If the DVD fails to start, open the launch.exe file located in the root directory of the DVD.

Notes:

- You should read and accept the Lenovo License Agreement when prompted.

- On the Microsoft Windows Server® 2003 operating system, you might need to add the Uniform Resource Locator (URL) for the ThinkServer EasyStartup program Web page to the trusted Web site list so that the page can open correctly.

You can do the following when using the ThinkServer EasyStartup program on a Windows operating system. For detailed information, refer to the help system.

- View a general introduction to your ThinkServer server model and the specific server configuration information.
- View general guidance on how to use the *ThinkServer EasyStartup* DVD.
- Download the required device drivers to a removable storage device so that you can easily get the drivers for server configuration when you need them, especially when you finish installing an operating system without using the *ThinkServer EasyStartup* DVD and need appropriate device drivers to configure your server.
- Install the required device drivers directly on the server on which you are running the *ThinkServer EasyStartup* DVD.
- View information about all server models supported by the ThinkServer EasyStartup program and information about the device drivers for each server model, including the driver versions and driver locations in the root directory of the *ThinkServer EasyStartup* DVD.

Note: The most up-to-date device drivers for various server models are always available for download on the Lenovo Support Web site at:
<http://www.lenovo.com/drivers>

Configuring RAID

This topic provides information about RAID and the utility programs that are available for you to configure RAID.

This topic contains the following items:

- “About RAID” on page 56
- “Configuring RAID using the ThinkServer EasyStartup program” on page 58
- “Configuring the ThinkServer RAID 300” on page 58
- “Configuring the advanced SATA/SAS hardware RAID” on page 63

About RAID

RAID, an acronym for Redundant Array of Independent Disks, is a technology that provides increased storage functions and reliability through redundancy. This is achieved by combining multiple hard disk drives into a logical unit, where data is distributed across the drives in one of several ways called RAID levels.

When a group of independent physical hard disk drives are set up to use RAID technology, they are in a RAID array. This array distributes data across multiple hard disk drives, but the array appears to the host server as one single storage unit. Creating and using RAID arrays provides high performance, such as the expedited I/O performance, because several drives can be accessed simultaneously.

RAID drive groups also improve data storage reliability and fault tolerance compared with single-drive storage systems. Data loss resulting from a drive failure can be prevented by reconstructing missing data from the remaining drives.

The following list describes some of the most commonly used RAID levels:

- **RAID 0:** block-level striping without parity or mirroring

Simple stripe sets are normally referred to as RAID 0. RAID 0 uses striping to provide high data throughput, especially for large files in an environment that does not require fault tolerance. RAID 0 has no redundancy and it provides improved performance and additional storage without fault tolerance. Any drive failure destroys the array and the likelihood of failure increases with more drives in the array. RAID 0 does not implement error checking, so any error is uncorrectable. More drives in the array means higher bandwidth, but greater risk of data loss.

RAID 0 requires a minimum number of two hard disk drives.

- **RAID 1:** mirroring without parity or striping

RAID 1 uses mirroring so that data written to one drive is simultaneously written to another drive. This is good for small databases or other applications that require small capacity but complete data redundancy. RAID 1 provides fault tolerance from disk errors or failures and continues to operate as long as at least one drive in the mirrored set is functioning. With appropriate operating system support, there can be increased read performance and only a minimal write performance reduction.

RAID 1 requires a minimum number of two hard disk drives.

- **RAID 5:** block-level striping with distributed parity

RAID 5 uses disk striping and parity data across all drives (distributed parity) to provide high data throughput, especially for small random access. RAID 5 distributes parity along with the data and requires all drives but one to be present to operate; drive failure requires replacement, but the array is not destroyed by a single drive failure. Upon drive failure, any subsequent read operations can be calculated from the distributed parity so that the drive failure is masked from the end user. The array will have data loss in the event of a second drive failure and is vulnerable until the data that was on the failing drive is rebuilt onto a replacement drive. A single drive failure in the set will result in reduced performance of the entire set until the failing drive has been replaced and rebuilt.

RAID 5 requires a minimum number of three hard disk drives.

- **RAID 10:** a combination of RAID 0 and RAID 1

RAID 10 consists of striped data across mirrored spans. A RAID 10 drive group is a spanned drive group that creates a striped set from a series of mirrored drives. RAID 10 allows a maximum of eight spans. You must use an even number of drives in each RAID virtual drive in the span. The RAID 1 virtual drives must have the same stripe size. RAID 10 provides high data throughput and complete data redundancy but uses a larger number of spans.

RAID 10 requires a minimum number of four hard disk drives and also requires an even number of drives, for example, six hard disk drives or eight hard disk drives.

- **RAID 50:** a combination of RAID 0 and RAID 5

RAID 50 uses distributed parity and disk striping. A RAID 50 drive group is a spanned drive group in which data is striped across multiple RAID 5 drive groups. RAID 50 works best with data that requires high reliability, high request rates, high data transfers, and medium-to-large capacity.

Note: Having virtual drives of different RAID levels, such as RAID 0 and RAID 5, in the same drive group is not allowed. For example, if an existing RAID 5 virtual drive is created out of partial space in an array, the next virtual drive in the array has to be RAID 5 only.

RAID 50 requires a minimum number of six hard disk drives.

For detailed information about RAID, refer to “Introduction to RAID” in the *MegaRAID SAS Software User Guide* on the documentation DVD that comes with your server.

Configuring RAID using the ThinkServer EasyStartup program

The ThinkServer EasyStartup program simplifies the process of configuring supported RAID and installing supported Windows and Linux operating systems and device drivers on your server. The user guide for the program can be accessed directly from the program interface.

The ThinkServer EasyStartup program has the following features for RAID configuration:

- For use with all supported RAID controllers
- Automatically detects hardware and lists all supported RAID configurations
- Configures one or more disk arrays per controller depending on the number of drives attached to the controller and the RAID level selected
- Supports hot-spare drives
- Creates a RAID response file that can be used to configure RAID controllers on similarly configured Lenovo servers

See “Using the ThinkServer EasyStartup program” on page 53 and view the user guide from the main interface of the program.

Some RAID management software also is provided on the *ThinkServer EasyStartup* DVD to help you manage RAID arrays and RAID controllers in an operating system environment. After you enter the operating system, insert the *ThinkServer EasyStartup* DVD into the optical drive. The installation packages for the programs are located in the Utilities and Others folder in the root directory of the DVD. The *ThinkServer EasyStartup* DVD is designed for different types of servers and the Utilities and Others folder might contain additional installation packages that are not required to be installed on your server.

Configuring the ThinkServer RAID 300

The ThinkServer RAID 300 (also known as onboard SAS software RAID) is integrated in the PCH on the system board. If you connect the mini-SAS to mini-SAS signal cables from the system board to the backplane, you can configure RAID for the hard disk drives using the LSI Software RAID Configuration Utility program, independently of the operating system. The ThinkServer RAID 300 supports RAID levels 0, 1, and 10 by default. You also can activate RAID 5 by installing a ThinkServer RAID 300 Upgrade Key for Advanced RAID. See “Installing or removing the ThinkServer RAID 300 Upgrade Key for Advanced RAID” on page 96.

You can install and use the MegaRAID Storage Manager program to manage the RAID array and RAID controller in an operating system environment.

Before configuring RAID for your server, observe the following precautions:

- Use hard disk drives that are of the same type (SATA or SAS) and have the same capacity within a single RAID array.
- The total drive capacity of the primary RAID array might be limited to 2 TB.

RAID array status

When you turn on the server, the RAID controller ROM version, the RAID array status, and the list of the available hard disk drives will be displayed during the POST.

The RAID array status can be one of the following:

- **Online**
This is the normal status, which indicates that the RAID array is working correctly.
- **Degrade**

This status indicates that more than one hard disk drive in the RAID array cannot be synchronized or have failed. You need to replace the failing hard disk drives and rebuild the data. See “Installing or replacing a hot-swap hard disk drive” on page 122 and “Rebuilding a physical drive” on page 62.

- **Offline**

This status indicates that the RAID array has failed and cannot be rebuilt. You need to create a new RAID array. See “Creating, adding, or deleting a RAID array” on page 60.

Starting the LSI Software RAID Configuration Utility program

This topic provides instructions on how to start the LSI Software RAID Configuration Utility program.

To start the LSI Software RAID Configuration Utility program, do the following:

1. Turn on the server.
2. During the POST, when you see the message “Press Ctrl-M or Enter to run LSI Software RAID Setup Utility,” immediately press Ctrl+M to start the LSI Software RAID Configuration Utility program.

LSI Software RAID Configuration Utility program interface

This topic provides information about the menus and items in the LSI Software RAID Configuration Utility program. Depending on the version of the program, some menu or item information might differ slightly from the information in this topic.

When working with the LSI Software RAID Configuration Utility program, you must use the keyboard. The keys used to perform various tasks are displayed on the bottom of each screen. Use up and down arrow keys to navigate between items. For most items, the corresponding help message is displayed on the bottom of the screen when the item is selected. If the item has submenus, you can display the submenus by pressing Enter.

After entering the LSI Software RAID Configuration Utility program, you can see the **Management Menu** on the screen. The **Management Menu** contains the following menu items:

- **Configure**

This menu contains items to help you create a RAID array, view the current RAID configuration, add a new RAID array, delete an existing RAID array, and select a boot virtual drive.

- **Initialize**

This menu helps you initialize virtual drive(s).

Note: Initializing a virtual drive erases all data on the virtual drive. Back up any data you want to keep and ensure that the operating system is not installed on the virtual drive before the initialization.

- **Objects**

This menu helps you configure parameters for the RAID controller, the virtual drive(s), and the physical drive(s).

- **Rebuild**

This menu helps you rebuild a physical drive in a RAID array in the event of a physical drive failure. You can choose to rebuild the data on the failing drive if the drive is still operational. If the drive is not operational, it must be replaced and the data on the failing drive must be rebuilt on a new drive to restore the system to fault tolerance.

- **Check Consistency**

This menu helps you do consistency check for the virtual drive(s). The consistency check verifies the correctness of the data on virtual drive(s) that use RAID 1, 5, and 10.

The following table shows the various menus and items in the LSI Software RAID Configuration Utility program. On each menu, press the Enter key to show selectable options and select a desired option by using up and down arrow keys or type desired values from the keyboard directly.

Table 3. LSI Software RAID Configuration Utility program menu items

Menu item	Submenu item	Comments
Configure	Easy Configuration	Create physical arrays. An array will automatically become a virtual drive.
	New Configuration	Clear the existing configuration and start a new configuration.
	View/Add Configuration	View the existing configuration or add a new configuration.
	Clear Configuration	Clear the existing configuration.
	Select Boot Drive	Select a boot virtual drive.
Initialize	Varies by configuration.	Initialize virtual drives.
Objects	Adapter	Set adapter related parameters, such as rebuild rate, consistency check rate, auto-rebuild, and so on.
	Virtual Drive	Set virtual drive parameters.
	Physical Drive	Set physical drive parameters, such as creating a hot-spare drive for the virtual drive, making a failing drive as online, changing a drive state, and viewing the specifications of a physical drive.
Rebuild	Varies by configuration.	Rebuild physical drive(s).
Check Consistency	Varies by configuration.	Check consistency of virtual drive(s).

Creating, adding, or deleting a RAID array

This topic provides instructions on how to create, add, or delete a RAID array using the LSI Software RAID Configuration Utility program.

Note: Before you create a RAID array using the LSI Software RAID Configuration Utility program, ensure that the server meets the required hardware configuration. For example, the server needs to have the required number of hard disk drives installed and connected to the system board. See “About RAID” on page 56 for information about the required number of hard disk drives for each RAID level. If you want to create a RAID 5 array using the LSI Software RAID Configuration Utility program, the server also needs to have a ThinkServer RAID 300 Upgrade Key for Advanced RAID. See “Installing or removing the ThinkServer RAID 300 Upgrade Key for Advanced RAID” on page 96.

To create, add, or delete a RAID array using the LSI Software RAID Configuration Utility program, do the following:

1. Start the LSI Software RAID Configuration Utility program. See “Starting the LSI Software RAID Configuration Utility program” on page 59.
2. On the main interface of the program, do one of the following depending on your needs:
 - If you want to create a RAID array, select **Easy Configuration** and then follow the instructions on the screen.
 - If you want to add a secondary RAID array (if supported by your server), select **View/Add Configuration** and then follow the instructions on the screen to view the current configuration and add a new RAID array.

- If you want to delete the existing RAID array, exit the program and back up all your data on the hard disk drives. After backing up all your data, enter the program main interface and select **Clear Configuration**. Select **Yes** when prompted and follow the instructions on the screen.

Attention: Deleting an existing RAID array erases all data on the array. Ensure that you back up all data before deleting the RAID array. If the operating system is installed on the RAID array you want to delete, you need to reinstall the operating system after deleting the RAID array.

- If you want to delete the existing RAID array and create a new RAID array, exit the program and back up all your data on the hard disk drives. After backing up all your data, enter the program main interface and select **New Configuration**. Select **Yes** when prompted to proceed and then follow the instructions on the screen.

Attention: Deleting an existing RAID array erases all data on the array. Ensure that you back up all data before deleting the RAID array. If the operating system is installed on the RAID array you want to delete, you need to reinstall the operating system after deleting the RAID array.

Initializing a virtual drive

This topic provides instructions on how to initialize a virtual drive using the LSI Software RAID Configuration Utility program after completing the configuration process.

Virtual drive initialization is the process of writing zeros to the data fields of a virtual drive and, in fault-tolerant RAID levels, generating the corresponding parity to put the virtual drive in a ready state. Initialization erases all data on the virtual drive. Drive groups will work without being initialized, but they can fail a consistency check because the parity fields have not been generated.

Notes:

- Ensure that you back up any data you want to keep before initializing a virtual drive.
- Ensure that the operating system is not installed on the virtual drive you are initializing. Otherwise, you need to reinstall the operating system after initializing the virtual drive.

To initialize a virtual drive using the LSI Software RAID Configuration Utility program, do the following:

1. Start the LSI Software RAID Configuration Utility program. See “Starting the LSI Software RAID Configuration Utility program” on page 59.
2. On the main interface of the program, select **Initialize** and follow the instructions on the screen.

Setting a hot-spare drive

This topic provides instructions on how to set a hard disk drive as a hot-spare drive using the LSI Software RAID Configuration Utility program.

A hot-spare drive is an extra, unused drive that is part of the disk subsystem. It is usually in standby mode and ready for service if a hard disk drive fails. For detailed information about hot-spare drives, refer to “Introduction to RAID” in the *MegaRAID SAS Software User Guide* on the documentation DVD that comes with your server.

To set a hard disk drive as a hot-spare drive using the LSI Software RAID Configuration Utility program, do the following:

1. Start the LSI Software RAID Configuration Utility program. See “Starting the LSI Software RAID Configuration Utility program” on page 59.
2. Do one of the following:
 - If you want to create or add a new RAID array, you can set a hot-spare drive during the configuration process by following the instructions on the screen.

- If you want to set a hot-spare drive right after the configuration, select **Objects → Physical Drive** from the program main interface. Then, select the hard disk drive that you want to set as a hot-spare drive and press Enter. A submenu is displayed. Select **Make Hot Spare** from the submenu and then select **Yes** when prompted to set the hard disk drive as a hot-spare drive.

Rebuilding a physical drive

This topic provides instructions on how to rebuild a physical drive using the LSI Software RAID Configuration Utility program when a physical drive in a RAID array fails.

When a physical drive in a RAID array fails, you can rebuild the drive by recreating the data that was stored on the drive before it fails. If the drive is not operational, it must be replaced and the data on the failing drive must be rebuilt on a new drive to restore the system to fault tolerance.

The RAID controller recreates the data using the data stored on other drives in the drive group. Rebuilding can be done only in drive groups with data redundancy, such as RAID 1, RAID 5, and RAID 10 arrays. For detailed information about disk rebuild, refer to “Introduction to RAID” in the *MegaRAID SAS Software User Guide* on the documentation DVD that comes with your server.

To rebuild a physical drive using the LSI Software RAID Configuration Utility program when a physical drive in a RAID array fails, do the following:

1. Start the LSI Software RAID Configuration Utility program. See “Starting the LSI Software RAID Configuration Utility program” on page 59.
2. On the main interface of the program, select **Rebuild** and follow the instructions on the screen.

Note: Run a consistency check immediately after the rebuild completes to ensure data integrity for the virtual drives. See “Running a consistency check” on page 62.

The rebuild rate is the percentage of the computing cycles dedicated to rebuilding failing drives. The rebuild rate can be configured between 0 percent and 100 percent. At 0 percent, the rebuild is done only if the system is not doing anything else. At 100 percent, the rebuild has a higher priority than any other system activity.

To configure the rebuild rate using the LSI Software RAID Configuration Utility program, do the following:

Note: Using a rebuild rate of 0 or 100 percent is not recommended. The default value is 30 percent.

1. Start the LSI Software RAID Configuration Utility program. See “Starting the LSI Software RAID Configuration Utility program” on page 59.
2. On the main interface of the program, select **Objects → Adapter → Rebuild Rate**.
3. Set the rebuild rate by typing a desired value from the keyboard directly.

Running a consistency check

This topic provides instructions on how to run a consistency check for virtual drives using the LSI Software RAID Configuration Utility program.

The consistency check operation verifies that all stripes on a virtual drive with a redundant RAID level (RAID 1, RAID 5, and RAID 10) are consistent and the date on the virtual drive is correct. For example, in a system with parity, checking consistency means computing the data on one drive and comparing the results to the contents of the parity drive.

You should run a consistency check on fault-tolerant virtual drives periodically. It is recommended that you run a consistency check at least once a month. You must run a consistency check if you suspect that the virtual drive data might be corrupted. Ensure that you back up the data before running a consistency check if you suspect that the data might be corrupted.

To run a consistency check using the LSI Software RAID Configuration Utility program, do the following:

1. Start the LSI Software RAID Configuration Utility program. See “Starting the LSI Software RAID Configuration Utility program” on page 59.
2. On the main interface of the program, select **Check Consistency** and follow the instructions on the screen.

The consistency check rate is the rate at which consistency check operations are run on a system. The consistency check rate can be configured between 0 percent and 100 percent. At 0 percent, the consistency check is done only if the system is not doing anything else. At 100 percent, the consistency check has a higher priority than any other system activity.

To configure the consistency check rate using the LSI Software RAID Configuration Utility program, do the following:

Note: Using a consistency check rate of 0 or 100 percent is not recommended. The default value is 30 percent.

1. Start the LSI Software RAID Configuration Utility program. See “Starting the LSI Software RAID Configuration Utility program” on page 59.
2. On the main interface of the program, select **Objects → Adapter → Chk Const Rate**.
3. Set the consistency check rate by typing a desired value from the keyboard directly.

Installing and using the MegaRAID Storage Manager program

You can install and use the MegaRAID Storage Manager program to manage the RAID array and RAID controller in an operating system environment after configuring RAID.

The installation package for the MegaRAID Storage Manager program is on the *ThinkServer EasyStartup* DVD. After you enter the operating system, insert the *ThinkServer EasyStartup* DVD into the optical drive. The installation package for the MegaRAID Storage Manager program is located in the Utilities and Others folder in the root directory of the DVD.

To install and use the MegaRAID Storage Manager program, refer to the following chapters in the *MegaRAID SAS Software User Guide* on the documentation DVD that comes with your server:

Note: Some information in these chapters might be intended for the advanced SATA/SAS hardware RAID configurations and might not apply to the ThinkServer RAID 300 configurations.

- “MegaRAID Storage Manager Overview and Installation”
- “MegaRAID Storage Manager Window and Menus”
- “Monitoring System Events and Storage Devices”
- “Maintaining and Managing Storage Configurations”

The *MegaRAID SAS Software User Guide* also is available on the Lenovo Web site at: <http://www.lenovo.com/ThinkServerUserGuides>

Configuring the advanced SATA/SAS hardware RAID

Before configuring RAID for your server, observe the following precautions:

- Use hard disk drives that are of the same type (SATA or SAS) and have the same capacity within a single RAID array.
- The total drive capacity of the primary RAID array might be limited to 2 TB.

Some server models come with a RAID card to provide advanced SATA/SAS hardware RAID functions. You also can purchase a supported RAID card from Lenovo and install it into the server. See “RAID card” on page 25.

The RAID card provides the WebBIOS Configuration Utility program to help you configure RAID independently of the operating system. You also can install the MegaRAID Storage Manager program and the MegaCLI Configuration Utility program to help you manage the RAID array and RAID controller in an operating system environment.

The installation packages for the MegaRAID Storage Manager program and the MegaCLI Configuration Utility program are on the *ThinkServer EasyStartup* DVD. After you enter the operating system, insert the *ThinkServer EasyStartup* DVD into the optical drive. The installation packages for the programs are located in the Utilities and Others folder in the root directory of the DVD.

Note: The *ThinkServer EasyStartup* DVD is designed for different types of servers and the Utilities and Others folder might contain additional installation packages that are not required to be installed on your server.

For instructions on how to configure and manage the advanced SATA/SAS hardware RAID, refer to the *MegaRAID SAS Software User Guide* on the documentation DVD that comes with your server. This document also is available on the Lenovo Web site at:
<http://www.lenovo.com/ThinkServerUserGuides>

Configuring the Ethernet controllers

The Ethernet controllers are integrated on the system board. They provide an interface for connecting to a 10 Mbps, 100 Mbps, or 1000 Mbps network and provide full-duplex (FDX) capability, which enables simultaneous transmission and reception of data on the network.

You do not have to set any jumpers or configure the Ethernet controllers. However, you must install a device driver to enable the operating system to recognize the controllers.

The ThinkServer EasyStartup program simplifies the process of configuring RAID and installing supported operating systems and device drivers on your server. See “Using the ThinkServer EasyStartup program” on page 53.

The device drivers for onboard Ethernet controllers also are available for download at:
<http://www.lenovo.com/drivers>

Updating the firmware

The firmware in the server is periodically updated and is available for download on the Lenovo Web site.

Go to <http://www.lenovo.com/drivers> and follow the instructions on the Web page to check for the latest level of firmware, such as the BIOS updates and device drivers.

When you replace a device in the server, you might have to either update the server with the latest version of the firmware that is stored in memory on the device or reflash the BIOS, the TMM firmware, and the FRU/SDR.

Using the Firmware Updater program

The Firmware Updater program enables you to maintain your system firmware up-to-date and helps you avoid unnecessary outages.

To update your system firmware using the Firmware Updater program, do the following:

Note: Before distributing the firmware updates to a server, ensure that your server can restart successfully without encountering hardware problems.

1. Go to <http://www.lenovo.com/drivers> and follow the instructions on the Web page to locate the Firmware Updater program.
2. Download the ISO image for the Firmware Updater program and the installation instructions in a TXT file.
3. Use any CD or DVD burning software to create a bootable disc with the ISO image.
4. Print the TXT file that contains the installation instructions and follow the instructions to use the Firmware Updater program to update your system firmware.

Using the Lenovo ThinkServer EasyManage program

The Lenovo ThinkServer EasyManage program enables enterprise users to remotely control and monitor multiple Lenovo servers within a LAN. The program provides an interface to display all servers being managed, which enables the administrator to conveniently search for, monitor, and manage servers.

To download the Lenovo ThinkServer EasyManage program, go to <http://www.lenovo.com/drivers> and follow the instructions on the Web page.

For detailed information about using the Lenovo ThinkServer EasyManage program, refer to the help system for the program.

Chapter 6. Installing, removing, or replacing hardware

This chapter provides instructions on how to install, remove, or replace hardware for your server.

This chapter contains the following items:

- “Guidelines” on page 67
- “Removing the server cover” on page 69
- “Installing, removing, or replacing hardware” on page 71
- “Completing the parts replacement” on page 147

For a list of the ThinkServer options, go to:
<http://www.lenovo.com/thinkserver>

Guidelines

This topic provides some guidelines that you should read and understand before using your server.

Precautions

Before you use the server, ensure that you read and understand the following precautions:

- Before using the product, be sure to read and understand the multilingual safety instructions and the Lenovo Limited Warranty (LLW) on the documentation DVD that comes with the product. Reading and understanding the safety instructions reduces the risk of personal injury and damage to your product.
- When you install your new server, take the opportunity to download and apply the most recent firmware updates. This step will help to ensure that any known issues are addressed and that your server is ready to function at maximum levels of performance. To download firmware updates for your server, go to <http://www.lenovo.com/drivers>, and then follow the instructions on the Web page. See “Updating the firmware” on page 64 for more information.
- Before you install optional hardware devices, ensure that the server is working correctly. If the server is not working correctly, see Chapter 7 “Troubleshooting and diagnostics” on page 153 to do basic troubleshooting. If the problem cannot be solved, see Chapter 8 “Getting information, help, and service” on page 159.
- Observe good housekeeping in the area where you are working. Put removed covers and other parts in a safe place.
- If you must turn on the server while the server cover is removed, ensure that no one is near the server and that no tools or other objects have been left inside the server.
- Do not attempt to lift an object that you think is too heavy for you. If you have to lift a heavy object, observe the following precautions:
 - Ensure that you can stand safely without slipping.
 - Distribute the weight of the object equally between your feet.
 - Use a slow lifting force. Never move suddenly or twist when you lift a heavy object.
 - To avoid straining the muscles in your back, lift by standing or by pushing up with your leg muscles.
- Ensure that you have an adequate number of properly grounded electrical outlets for the server, monitor, and other devices.
- Back up all important data before you make changes to drives.
- Have a small flat-blade screwdriver available.

- You do not have to turn off the server to install or replace a hot-swap redundant power supply, a hot-swap hard disk drive, or a hot-plug USB device. However, you must turn off the server before performing any step that involves installing, removing, or replacing adapter cables or non-hot-swap devices or components.
- To view the LEDs on the system board and internal components, leave the server connected to power.
- When you are finished working on the server, reinstall all safety shields, guards, labels, and ground wires.
- When working inside the server, you might find some tasks easier if you lay the server on its side.

Handling static-sensitive devices

Attention: Do not open the static-protective package that contains the new part until the defective part has been removed from the server and you are ready to install the new part. Static electricity, although harmless to you, can seriously damage server components and parts.

Any server part containing transistors or integrated circuits (ICs) should be considered sensitive to electrostatic discharge (ESD). ESD damage can occur when there is a difference in charge between objects. Protect against ESD damage by equalizing the charge so that the machine, the part, the work mat, and the person handling the part are all at the same charge.

Notes:

- Use product-specific ESD procedures when they exceed the requirements noted here.
- Ensure that the ESD protective devices you use have been certified (ISO 9000) as fully effective.

When you handle server parts and components, take these precautions to avoid static-electricity damage:

- Limit your movement. Movement can cause static electricity to build up around you.
- Always carefully handle the parts and other components (such as PCI Express cards, memory modules, system boards, and microprocessors) by edges or frame. Do not touch solder joints, pins, or exposed circuitry.
- Do not leave the device where others can handle and possibly damage the device.
- Before you replace a new part, touch the static-protective package containing the new part to an unpainted metal part of the server for at least two seconds. This reduces static electricity from the package and your body.
- Remove the new part from the static-protective package and directly install it in the server without placing it on any other surface. If it is hard for you to do this in your specific situation, place the static-protective package of the new part on a smooth, level surface, and then place the new part on the static-protective package.
- Do not place the part on the server cover or other metal surface.
- Take additional care when handling devices during cold weather. Heating reduces indoor humidity and increases static electricity.
- Use a grounded work mat to provide a static-free work surface. The mat is especially useful when handling ESD-sensitive devices.
- Prevent the part from touching your clothing. Most clothing is insulative and retains a charge even when you are wearing a wrist strap.
- The use of a grounding system is recommended. For example, it is recommended to wear an electrostatic discharge (ESD) wrist strap, if one is available. Ensure that you work in an ESD-safe area. Select a grounding system, such as those listed below, to provide protection that meets the specific service requirement.

Note: The use of a grounding system to guard against ESD damage is desirable but not necessary.

- Attach the ESD ground clip to any frame ground, ground braid, or green-wire ground.
- When working on a double-insulated or battery-operated system, use an ESD common ground or reference point. You can use coax or connector-outside shells on these systems.
- Use the ground prong of the ac plug on ac-operated servers.

System reliability guidelines

To help ensure proper cooling and system reliability, strictly follow these guidelines:

- Each of the drive bays has a drive or a dummy tray installed.
- If the server supports hot-swap redundant power supplies, each of the power supply bay has a redundant power supply installed, or one bay has a redundant power supply installed while the other bay is covered by a shield.
- Leave adequate space around the server to ensure that the server cooling system works well. Leave approximately 50 mm (2 inches) of open space around the front and rear of the server. Do not place objects in front of the fans. For proper cooling and airflow, install the server cover before you turn on the server. Operating the server for extended periods of time (more than 30 minutes) with the server cover removed might damage server components.
- Properly route the cables. For some options, such as PCI Express cards, follow the cabling instructions that come with the options in addition to the instructions in this manual.
- When replacing a hot-swap drive, install the new hot-swap drive within two minutes of removal.
- If your server has air ducts or air baffles, do not remove them while the server is running. Operating the server without the air ducts or air baffles might cause the microprocessor(s) to overheat.
- For servers that support up to two microprocessors, ensure that the second microprocessor socket always contains a microprocessor or is protected by a microprocessor socket cover.

Working inside the server with the power on

Attention: Static electricity that is released to internal server components when the server is turned on might cause the server to halt, which might result in the loss of data. To avoid this potential problem, always use an ESD wrist strap or other grounding system when you work inside the server with the power on.

The server supports hot-swap devices and is designed to operate safely while it is turned on and the cover is removed. Follow these guidelines when you work inside the server with the power on:

- Avoid wearing loose-fitting clothing on your forearms. Button long-sleeved shirts before working inside the server; do not wear cuff links while you are working inside the server.
- Do not allow your necktie or scarf to hang inside the server.
- Remove jewelry, such as bracelets, necklaces, rings, and loose-fitting wrist watches.
- Remove items from your shirt pocket, such as pens and pencils. These items might fall into the server as you lean over it.
- Avoid dropping any metallic objects into the server, such as paper clips, hairpins, and screws.

Removing the server cover

Attention: Do not open your server or attempt any repair before reading and understanding “Safety information” on page iii and “Guidelines” on page 67.

This topic provides instructions on how to remove the server cover.

Before you begin, print all the related instructions or ensure that you can view the PDF version on another computer for reference.

Note: Depending on the model, your server might look slightly different from the illustrations in this topic.

To remove the server cover, do the following:

1. Remove all media from the drives and turn off all attached devices and the server. Then, disconnect all power cords from electrical outlets.
2. Disconnect the power cords, Input/Output (I/O) cables, and all other cables that are connected to the server.
3. If the server is installed in a rack cabinet, remove the server from the rack cabinet and place it on a flat, clean, and static-protective surface. See the *Rack Installation Instructions* that comes with the server.
4. Press the release button **1** in the direction as shown.

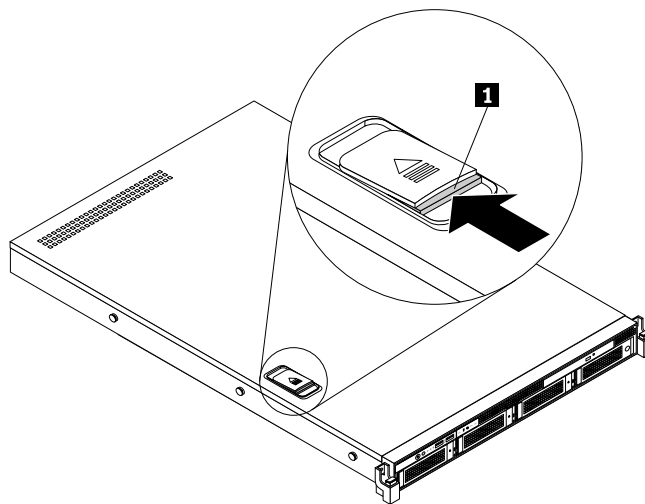

Figure 27. Pressing the release button

5. Fully open the cover latch **1** and slide the server cover to the rear until it is disengaged from the chassis. Then, lift the server cover off the chassis and set it aside.

Note: It is recommended that you wait three to five minutes to let the server cool before removing the server cover.

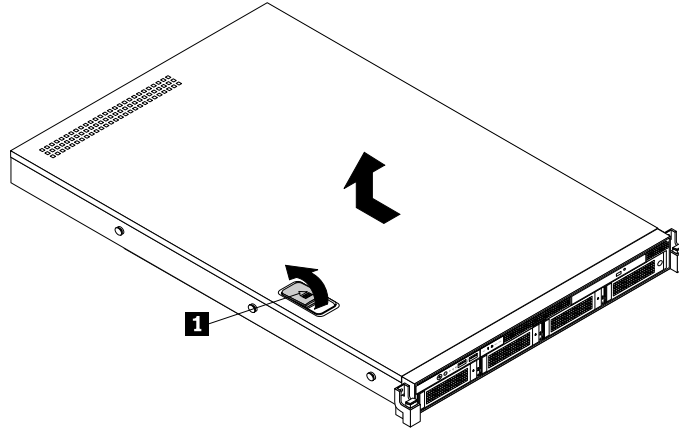

Figure 28. Removing the server cover

Attention: For proper cooling and airflow, install the server cover before turning on the server. Operating the server for more than 30 minutes with the server cover removed might damage server components.

To reinstall the server cover, see “Reinstalling the server cover and reconnecting cables” on page 147.

Installing, removing, or replacing hardware

This topic provides instructions on how to install, remove, or replace hardware for your server. You can expand the capabilities of your server by adding new hardware devices, such as memory modules or other server options, and maintain your server by replacing the failing hardware devices.

If you are handling a server option, refer to the appropriate installation or removal instructions in this topic along with the instructions that come with the option.

Notes:

- Use only parts provided by Lenovo.
- Depending on the model, your server might look slightly different from the illustrations in this topic.

The EMI integrity and cooling of the server are protected by having all drive bays and PCI Express card slots covered or occupied. When you install an internal drive or a PCI Express card, save the EMI shield or dummy tray from the drive bay or save the PCI Express card slot bracket in the event that you later remove the device.

Attention: An unoccupied drive bay or PCI Express card slot without a cover, shield, dummy tray, filler, or any other protection might impact the EMI integrity and cooling of the server, which might result in overheating or component damage.

Removing and reinstalling the rack handles

<p>Attention: Do not open your server or attempt any repair before reading and understanding “Safety information” on page iii and “Guidelines” on page 67.</p>

This topic provides instructions on how to remove and reinstall the rack handles.

Before you begin, print all the related instructions or ensure that you can view the PDF version on another computer for reference.

Note: Depending on the model, your server might look slightly different from the illustrations in this topic.

To remove and reinstall the rack handles, do the following:

1. On each side of the server, remove the screw that secures the rack handle and then remove the rack handle from the chassis.

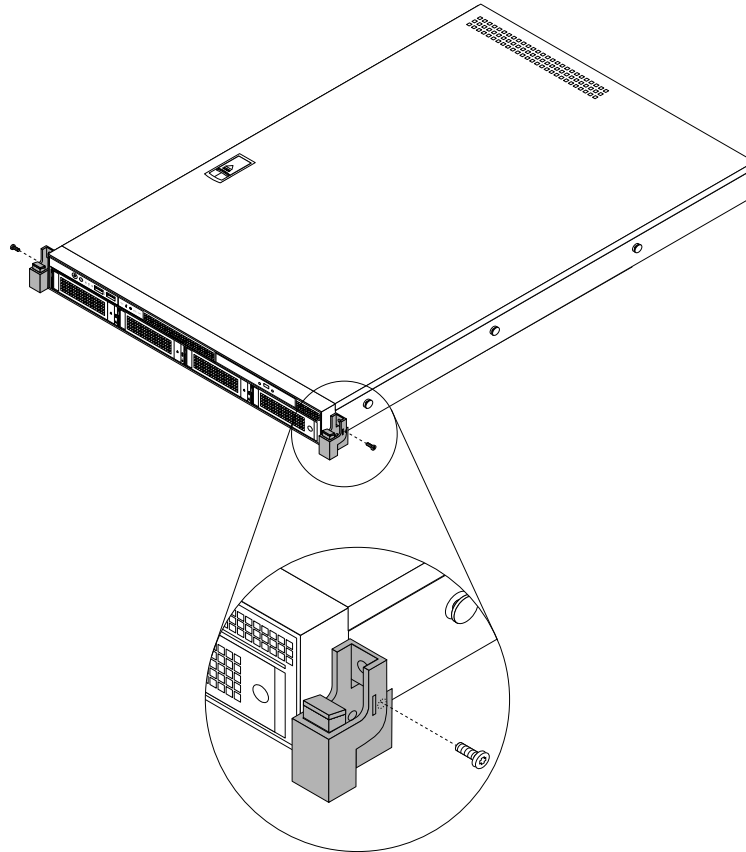

Figure 29. Removing the rack handles

2. To reinstall the rack handles, insert the small tab **1** on the rack handle into the hole **2** in the chassis. Then, align the screw hole in the rack handle with the corresponding hole in the chassis and install the screw to secure the rack handle on each side of the server.

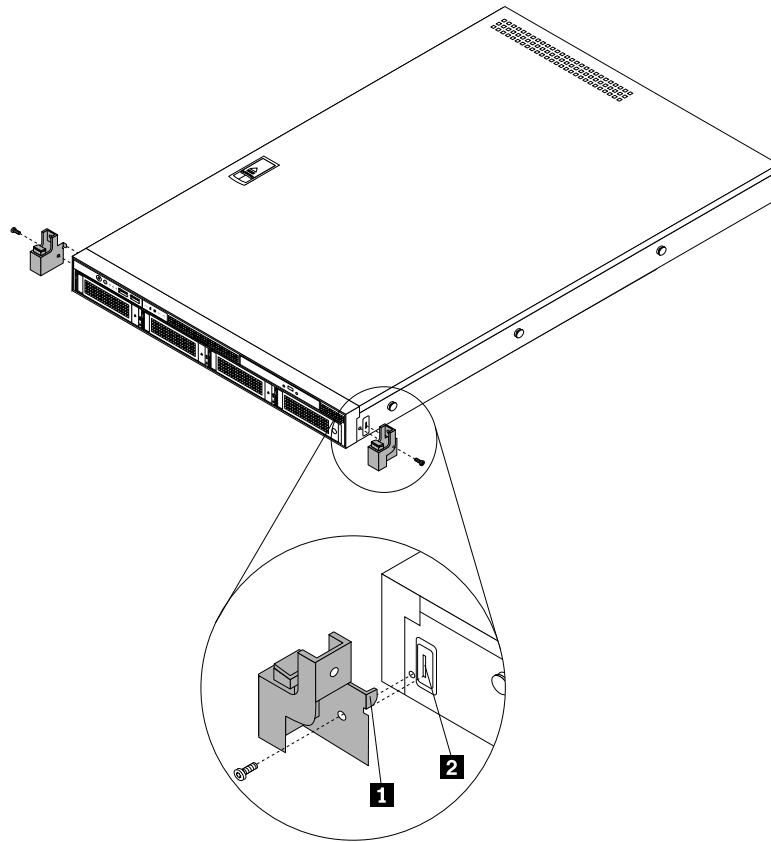

Figure 30. Installing the rack handles

Removing and reinstalling the cooling shroud

The cooling shroud must be removed to allow access to most server components. This topic provides instructions on how to remove and reinstall the cooling shroud.

Removing the cooling shroud

Attention: Do not open your server or attempt any repair before reading and understanding “Safety information” on page iii and “Guidelines” on page 67.

This topic provides instructions on how to remove the cooling shroud.

Before you begin, print all the related instructions or ensure that you can view the PDF version on another computer for reference.

Note: Depending on the model, your server might look slightly different from the illustrations in this topic.

To remove the cooling shroud, do the following:

1. Remove all media from the drives and turn off all attached devices and the server. Then, disconnect all power cords from electrical outlets and disconnect all cables that are connected to the server.

2. If the server is installed in a rack cabinet, remove the server from the rack cabinet and place it on a flat, clean, and static-protective surface. See the *Rack Installation Instructions* that comes with the server.
3. Remove the server cover. See “Removing the server cover” on page 69.
4. Insert a finger into each of the two holes in the cooling shroud and then lift the cooling shroud out of the server.

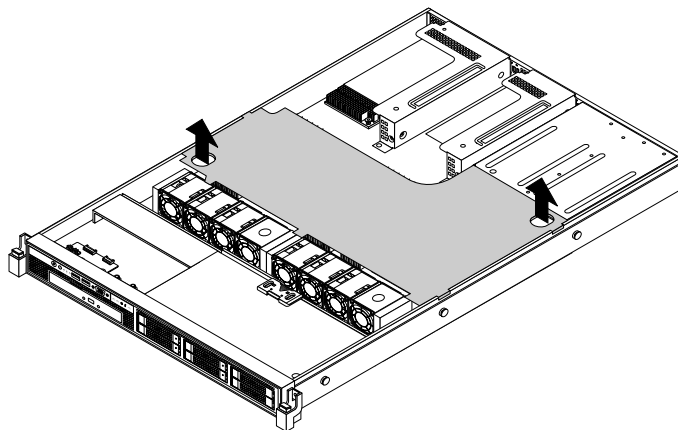

Figure 31. Removing the cooling shroud

Attention: For proper cooling and airflow, reinstall the cooling shroud before turning on the server. Operating the server for more than 30 minutes with the cooling shroud removed might damage server components.

Reinstalling the cooling shroud

Attention: Do not open your server or attempt any repair before reading and understanding “Safety information” on page iii and “Guidelines” on page 67.

This topic provides instructions on how to reinstall the cooling shroud.

Before you begin, print all the related instructions or ensure that you can view the PDF version on another computer for reference.

Note: Depending on the model, your server might look slightly different from the illustrations in this topic.

To reinstall the cooling shroud, do the following:

1. Ensure that all components have been reassembled correctly and that no tools or loose screws are left inside your server.
2. Ensure that all cables inside the server have been properly routed so that they will not interfere with installing the cooling shroud.

- Note the orientation of the cooling shroud and then place it above the server so that the tabs on both sides of the cooling shroud are aligned with the corresponding holes or gaps in both sides of the chassis. Then, lower the cooling shroud into the chassis until it snaps into position.

Note: If necessary, gently press the cooling shroud on both sides so that the tabs on the cooling shroud completely engage with both sides of the chassis.

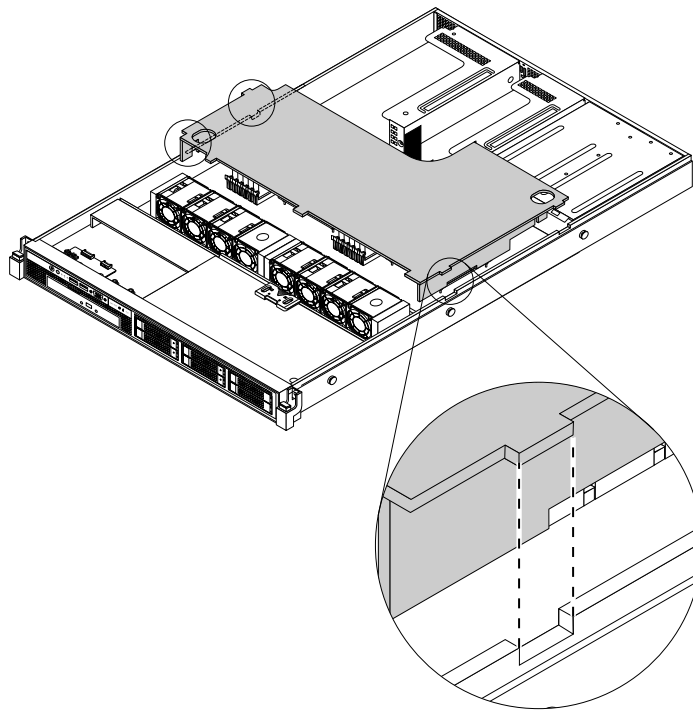

Figure 32. Reinstalling the cooling shroud

- Go to “Reinstalling the server cover and reconnecting cables” on page 147.

Installing or removing a memory module

This topic provides instructions on how to install or remove a memory module.

Note: The memory modules are extremely sensitive to ESD. Ensure that you read and understand “Handling static-sensitive devices” on page 68 first and carefully perform the operation.

Memory module installation rules

Your server has 12 memory slots and it has the following features:

- Each slot supports 4 GB, 8 GB, and 16 GB 1333 MHz double data rate 3 low-voltage registered dual inline memory modules (DDR3 LV RDIMMs).
- Each slot supports 4 GB, 8 GB, and 16 GB 1333 MHz DDR3 RDIMMs.
- Each slot supports 2 GB and 4 GB 1333 MHz DDR3 unbuffered dual inline memory modules (UDIMMs) with Error Checking and Correcting (ECC) technology.
- Your server supports up to six memory modules when one microprocessor is installed and up to 12 memory modules when two microprocessors are installed.
- The minimum system memory for RDIMMs or LV RDIMMs is 4 GB (only one microprocessor installed and only one 4 GB RDIMM or LV RDIMM installed in the CPU1 DIMMA1 slot).

- The minimum system memory for UDIMMs is 2 GB (only one microprocessor installed and only one 2 GB UDIMM installed in the CPU1 DIMMA1 slot).
- The maximum system memory for RDIMMs or LV RDIMMs is 192 GB (two microprocessors installed and one 16 GB RDIMM or LV RDIMM installed in each of the 12 memory slots).
- The maximum system memory for UDIMMs is 48 GB (two microprocessors installed and one 4 GB UDIMM installed in each of the 12 memory slots).

For more information about the memory modules in your specific server model, use the Setup Utility program. See “Viewing information in the Setup Utility program” on page 45.

For a list of the supported ThinkServer memory module options, go to:
<http://www.lenovo.com/thinkserver>

The following illustration shows the locations of all memory slots on a system board that has two microprocessors (also known as CPUs) installed.

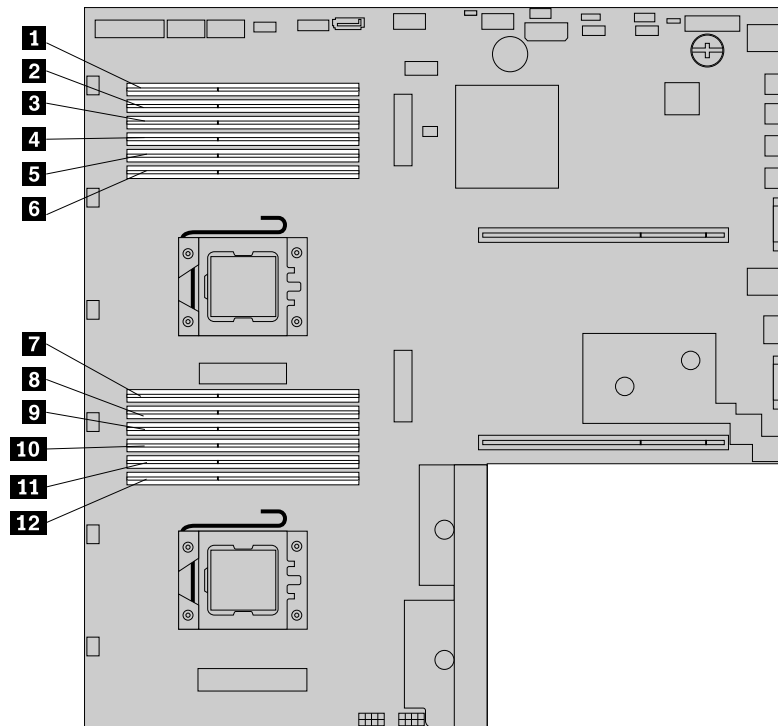

Figure 33. Memory slots on the system board

1 Memory slot (CPU1 DIMMA1)	7 Memory slot (CPU2 DIMMA1)
2 Memory slot (CPU1 DIMMA2)	8 Memory slot (CPU2 DIMMA2)
3 Memory slot (CPU1 DIMMB1)	9 Memory slot (CPU2 DIMMB1)
4 Memory slot (CPU1 DIMMB2)	10 Memory slot (CPU2 DIMMB2)
5 Memory slot (CPU1 DIMMC1)	11 Memory slot (CPU2 DIMMC1)
6 Memory slot (CPU1 DIMMC2)	12 Memory slot (CPU2 DIMMC2)

The following table explains the memory module installation rules for servers that have only one microprocessor (CPU1) installed. The “X” mark indicates the memory slot(s) into which the memory module(s) should be installed in different situations.

Note: All memory modules to be installed on a server must be the same type (LV RDIMM, RDIMM, or UDIMM) with the same rank, voltage, and frequency.

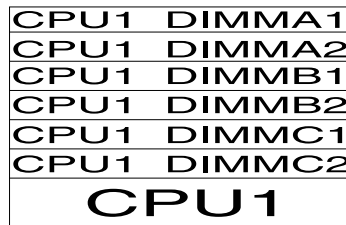

Figure 34. CPU1 DIMMs

Table 4. Memory module installation rules for servers with one microprocessor

CPU1 DIMM	A1	A2	B1	B2	C1	C2
One DIMM	X					
Two DIMMs	X		X			
Three DIMMs	X		X		X	
Four DIMMs	X	X	X		X	
Six DIMMs	X	X	X	X	X	X

The following table explains the memory module installation rules for servers that have two microprocessors (CPU1 and CPU2) installed. The “X” mark indicates the memory slot(s) into which the memory module(s) should be installed in different situations.

Note: All memory modules to be installed on a server must be the same type (LV RDIMM or RDIMM) with the same rank, voltage, and frequency.

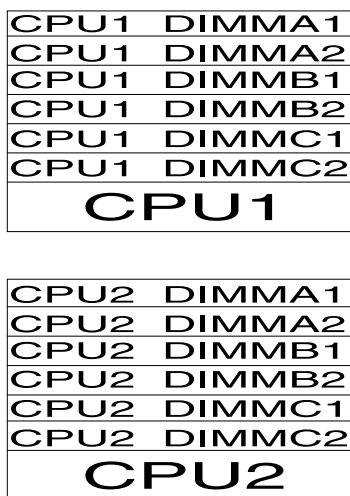

Figure 35. CPU1 DIMMs and CPU2 DIMMs

Table 5. Memory module installation rules for servers with two microprocessors

	CPU1 DIMM						CPU2 DIMM					
	A1	A2	B1	B2	C1	C2	A1	A2	B1	B2	C1	C2
Two DIMMs	X						X					
Four DIMMs	X		X				X		X			
Six DIMMs	X		X		X		X		X		X	
Eight DIMMs	X	X	X		X		X	X	X		X	
Twelve DIMMs	X	X	X	X	X	X	X	X	X	X	X	X

Installing a memory module

Attention: Do not open your server or attempt any repair before reading and understanding “Safety information” on page iii and “Guidelines” on page 67.

This topic provides instructions on how to install a memory module.

Before you begin, print all the related instructions or ensure that you can view the PDF version on another computer for reference.

Notes:

- To optimize system performance, ensure that you consider and follow the memory module installation rules when performing the operation. See “Memory module installation rules” on page 75.
- Use any documentation that comes with the memory module and follow those instructions in addition to the instructions in this topic.

To install a memory module, do the following:

1. Remove all media from the drives and turn off all attached devices and the server. Then, disconnect all power cords from electrical outlets and disconnect all cables that are connected to the server.
2. If the server is installed in a rack cabinet, remove the server from the rack cabinet and place it on a flat, clean, and static-protective surface. See the *Rack Installation Instructions* that comes with the server.
3. Remove the server cover. See “Removing the server cover” on page 69.
4. Remove the cooling shroud. See “Removing and reinstalling the cooling shroud” on page 73.
5. Locate the memory slots on the system board and read the memory module installation rules. See “Memory module installation rules” on page 75.
6. Disconnect any cables that might prevent your access to the memory slots.
7. Open the retaining clips of the appropriate memory slot.

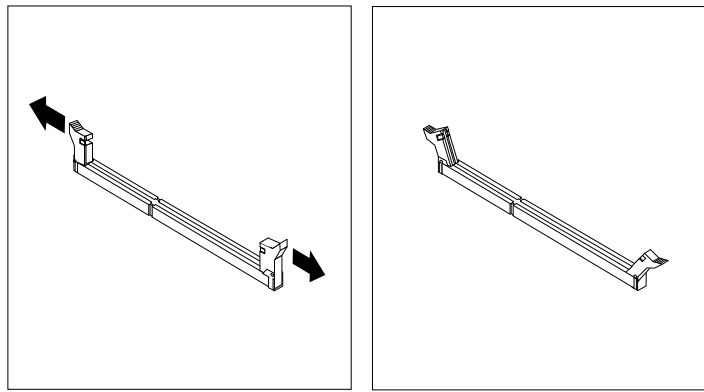

Figure 36. Opening the retaining clips of the memory slots

8. Touch the static-protective package that contains the new memory module to any unpainted surface on the outside of the server. Then, take the new memory module out of the package.

Note: Carefully handle the memory module by its edges.

- Position the new memory module over the memory slot. Ensure that the notch **1** on the new memory module is aligned with the key **2** in the memory slot. Then, press the new memory module straight down into the memory slot until the retaining clips close and the new memory module snaps into position.

Note: If there is a gap between the memory module and the retaining clips, the memory module has not been installed correctly. Open the retaining clips, remove the memory module, and then reinstall it into the memory slot until the retaining clips are completely closed.

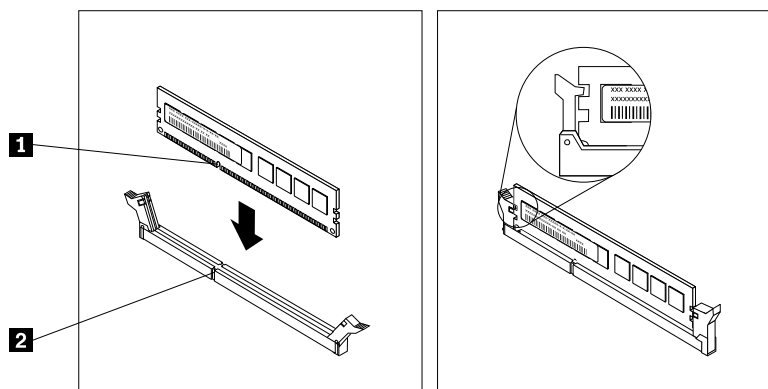

Figure 37. Installing a memory module

- Reconnect any cables that you have disconnected.

What to do next:

- To work with another piece of hardware, go to the appropriate section.
- To complete the installation, go to “Completing the parts replacement” on page 147.

Removing a memory module

Attention: Do not open your server or attempt any repair before reading and understanding “Safety information” on page iii and “Guidelines” on page 67.

This topic provides instructions on how to remove a memory module.

Before you begin, print all the related instructions or ensure that you can view the PDF version on another computer for reference.

Note: To optimize system performance, ensure that you consider and follow the memory module installation rules when performing the operation. See “Memory module installation rules” on page 75.

To remove a memory module, do the following:

- Remove all media from the drives and turn off all attached devices and the server. Then, disconnect all power cords from electrical outlets and disconnect all cables that are connected to the server.
- If the server is installed in a rack cabinet, remove the server from the rack cabinet and place it on a flat, clean, and static-protective surface. See the *Rack Installation Instructions* that comes with the server.
- Remove the server cover. See “Removing the server cover” on page 69.
- Remove the cooling shroud. See “Removing and reinstalling the cooling shroud” on page 73.
- Locate the memory slots on the system board and read the memory module installation rules. See “Memory module installation rules” on page 75.

6. Disconnect any cables that might prevent your access to the memory slots.
7. Locate the memory module that you want to remove and open the retaining clips on both ends of the memory slot. Then, grasp the memory module by its edges and carefully pull it straight up to remove it from the memory slot.

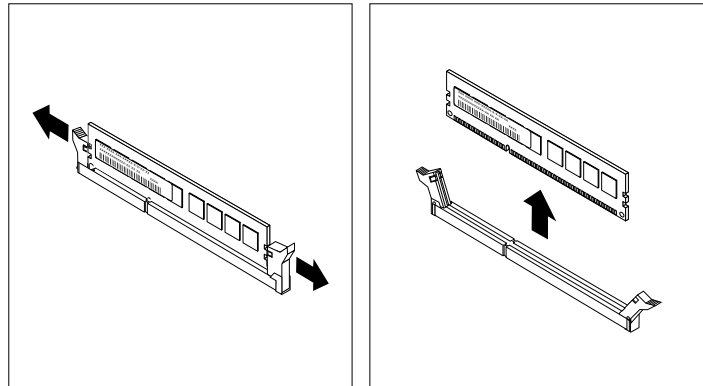

Figure 38. Removing a memory module

8. Reconnect any cables that you have disconnected.
9. If you are instructed to return the old memory module, follow all packaging instructions and use any packaging materials that are supplied to you for shipping.

What to do next:

- To work with another piece of hardware, go to the appropriate section.
- To complete the removal procedure, go to “Completing the parts replacement” on page 147.

Installing or removing the Ethernet card

This topic provides instructions on how to install or remove the Ethernet card. If you are installing or removing any other types of supported PCI Express cards, the procedure is similar.

Note: The Ethernet card is extremely sensitive to ESD. Ensure that you read and understand “Handling static-sensitive devices” on page 68 first and carefully perform the operation.

Installing the Ethernet card

Attention: Do not open your server or attempt any repair before reading and understanding “Safety information” on page iii and “Guidelines” on page 67.

This topic provides instructions on how to install the Ethernet card.

Before you begin, print all the related instructions or ensure that you can view the PDF version on another computer for reference.

Notes:

- Use any documentation that comes with the Ethernet card and follow those instructions in addition to the instructions in this topic.
- Depending on the specific type, the Ethernet card might look different from the illustrations in this topic.

To install the Ethernet card, do the following:

1. Remove all media from the drives and turn off all attached devices and the server. Then, disconnect all power cords from electrical outlets and disconnect all cables that are connected to the server.
2. If the server is installed in a rack cabinet, remove the server from the rack cabinet and place it on a flat, clean, and static-protective surface. See the *Rack Installation Instructions* that comes with the server.
3. Remove the server cover. See “Removing the server cover” on page 69.
4. Remove the riser card assembly 1 and lay it upside down on a flat, clean, and static-protective surface. See “Replacing the riser card assembly 1” on page 143.

Note: Usually an Ethernet card is installed on the riser card assembly 1 and also can be installed in any PCI Express card slot that supports it. See “Rear view of the server” on page 20 to identify the PCI Express card slots of your server.

5. Locate the PCI Express card slot for installing the Ethernet card and then remove the PCI Express card slot bracket from the riser card assembly 1. Store the PCI Express card slot bracket in the event that you later remove the Ethernet card and need the bracket to cover the place.

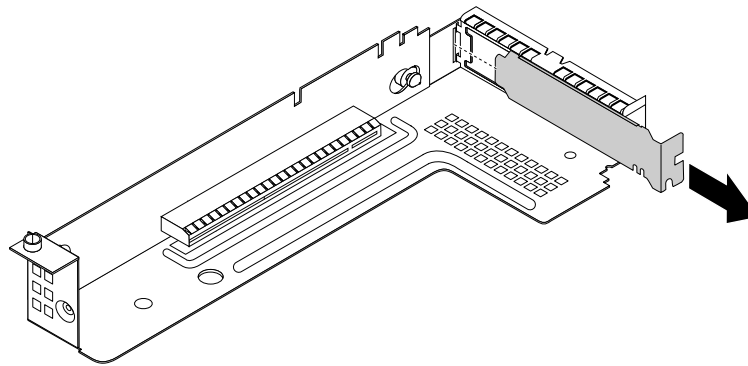

Figure 39. Removing a PCI Express card slot bracket

6. Touch the static-protective package that contains the Ethernet card to any unpainted surface on the outside of the server. Then, take the Ethernet card out of the package.

Note: Carefully handle the Ethernet card by its edges.

7. Position the Ethernet card near the PCI Express card slot and align the tab of the Ethernet card with the hole in the riser card assembly 1. Then, press the Ethernet card straight into the slot until it is securely seated in the slot.

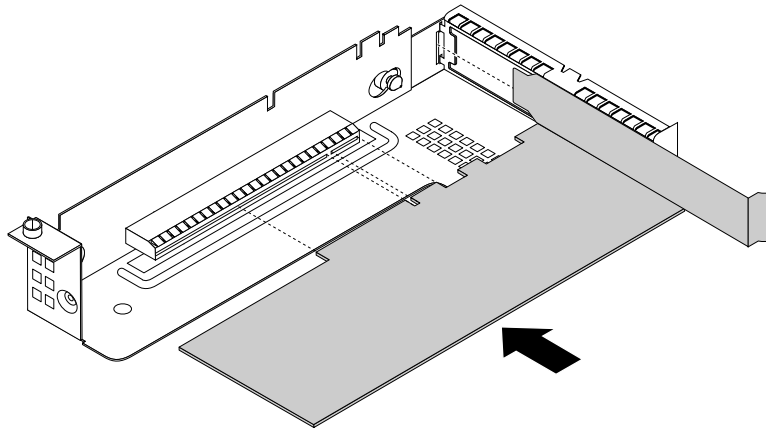

Figure 40. Installing the Ethernet card

8. Depending on the type of the Ethernet card, you might need to connect any required cables. Refer to the documentation that comes with the Ethernet card for specific information.
9. Reinstall the riser card assembly 1. See “Replacing the riser card assembly 1” on page 143.

What to do next:

- To work with another piece of hardware, go to the appropriate section.
- To complete the installation, go to “Completing the parts replacement” on page 147. Then, continue with the following procedure to install the Ethernet card driver if required.

To install the required device driver for the Ethernet card, do one of the following:

Note: You do not need to use the driver disc that might come with the Ethernet card.

- If you are using a Windows operating system, run the *ThinkServer EasyStartup* DVD that comes with your server and follow the instructions on the screen to download and install the required Ethernet card driver to the server. For more information, see “Using the ThinkServer EasyStartup program on a Windows operating system” on page 55.
- If you are using a Linux operating system, run the *ThinkServer EasyStartup* DVD that comes with your server on a computer with a Windows operating system and download the required Ethernet card driver to a removable storage device. Then, transfer the Ethernet card driver from the removable storage device to your server and run the driver file to install the driver.

The most up-to-date device drivers for various server models are always available for download on the Lenovo Support Web site at:

<http://www.lenovo.com/drivers>

Removing the Ethernet card

Attention: Do not open your server or attempt any repair before reading and understanding “Safety information” on page iii and “Guidelines” on page 67.

This topic provides instructions on how to remove the Ethernet card.

Before you begin, print all the related instructions or ensure that you can view the PDF version on another computer for reference.

Notes:

- Use any documentation that comes with the Ethernet card and follow those instructions in addition to the instructions in this topic.
- Depending on the specific type, the Ethernet card might look different from the illustration in this topic.

To remove the Ethernet card, do the following:

1. Remove all media from the drives and turn off all attached devices and the server. Then, disconnect all power cords from electrical outlets and disconnect all cables that are connected to the server.
2. If the server is installed in a rack cabinet, remove the server from the rack cabinet and place it on a flat, clean, and static-protective surface. See the *Rack Installation Instructions* that comes with the server.
3. Remove the server cover. See “Removing the server cover” on page 69.
4. Remove the riser card assembly 1 and lay it upside down on a flat, clean, and static-protective surface. See “Replacing the riser card assembly 1” on page 143.

Note: Usually an Ethernet card is installed on the riser card assembly 1 and also can be installed in any PCI Express card slot that supports it. See “Rear view of the server” on page 20 to identify the PCI Express card slots of your server.

5. Locate the Ethernet card on the riser card assembly 1. Depending on the type of the Ethernet card, you might need to disconnect all cables from the Ethernet card. Then, grasp the Ethernet card by its edges and carefully pull it out of the riser card assembly 1.

Note: The Ethernet card might fit tightly into the PCI Express card slot. If necessary, alternate moving each side of the Ethernet card a small and equal amount until it is completely removed from the slot.

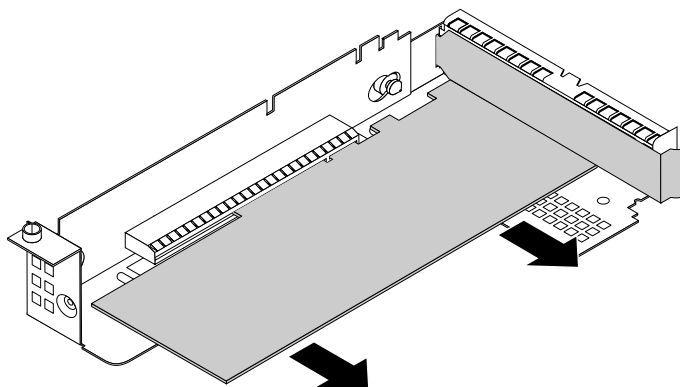

Figure 41. Removing the Ethernet card

6. Install a new Ethernet card to replace the old one or install a PCI Express card slot bracket to cover the place. See “Installing the Ethernet card” on page 81.
7. Reinstall the riser card assembly 1. See “Replacing the riser card assembly 1” on page 143.
8. If you are instructed to return the old Ethernet card, follow all packaging instructions and use any packaging materials that are supplied to you for shipping.

What to do next:

- To work with another piece of hardware, go to the appropriate section.

- To complete the removal procedure, go to “Completing the parts replacement” on page 147.

Installing or removing the RAID card

This topic provides instructions on how to install or remove the RAID card.

Some server models come with a required RAID card to provide advanced SATA/SAS hardware RAID functions to the server. You also can purchase a supported RAID card from Lenovo and install it into the server. For more information, see “RAID card” on page 25 and “Configuring RAID” on page 56.

Note: The RAID card is extremely sensitive to ESD. Ensure that you read and understand “Handling static-sensitive devices” on page 68 first and carefully perform the operation.

Installing the RAID card

Attention: Do not open your server or attempt any repair before reading and understanding “Safety information” on page iii and “Guidelines” on page 67.

This topic provides instructions on how to install the RAID card.

Before you begin, print all the related instructions or ensure that you can view the PDF version on another computer for reference.

Notes:

- Use any documentation that comes with the RAID card and follow those instructions in addition to the instructions in this topic.
- Depending on the specific type, the RAID card and its bracket might look different from the illustrations in this topic.
- Ensure that you back up your data before installing the RAID card because you might need to reconfigure RAID and reinstall the operating system after installing the RAID card.
- If you want to install any other PCI Express card your server supports to the riser card assembly 2, refer to the following installation procedure.

To install the RAID card, do the following:

1. Remove all media from the drives and turn off all attached devices and the server. Then, disconnect all power cords from electrical outlets and disconnect all cables that are connected to the server.
2. If the server is installed in a rack cabinet, remove the server from the rack cabinet and place it on a flat, clean, and static-protective surface. See the *Rack Installation Instructions* that comes with the server.
3. Remove the server cover. See “Removing the server cover” on page 69.
4. Remove the cooling shroud. See “Removing and reinstalling the cooling shroud” on page 73.
5. Remove the riser card assembly 2 and lay it upside down on a flat, clean, and static-protective surface. The procedure is similar to that of the riser card assembly 1. See “Replacing the riser card assembly 1” on page 143.

6. Locate the PCI Express card slot for installing the RAID card and then remove the PCI Express card slot bracket from the riser card assembly 2. Store the PCI Express card slot bracket in the event that you later remove the RAID card and need the bracket to cover the place.

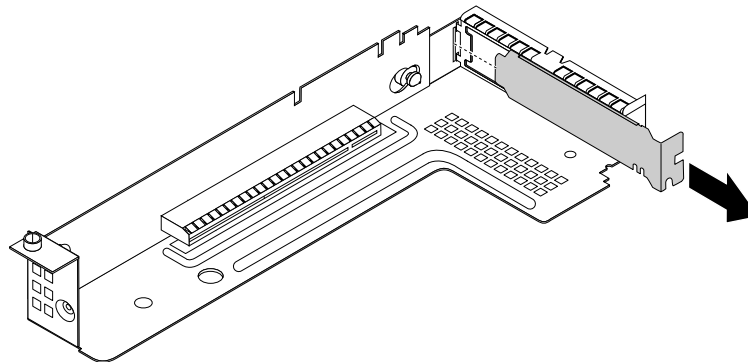

Figure 42. Removing a PCI Express card slot bracket

7. Touch the static-protective package that contains the RAID card to any unpainted surface on the outside of the server. Then, take the RAID card and the low-profile bracket out of the package.

Note: Carefully handle the RAID card by its edges.

8. Remove the two screws that secure the RAID card and then remove the full-height bracket from the RAID card.

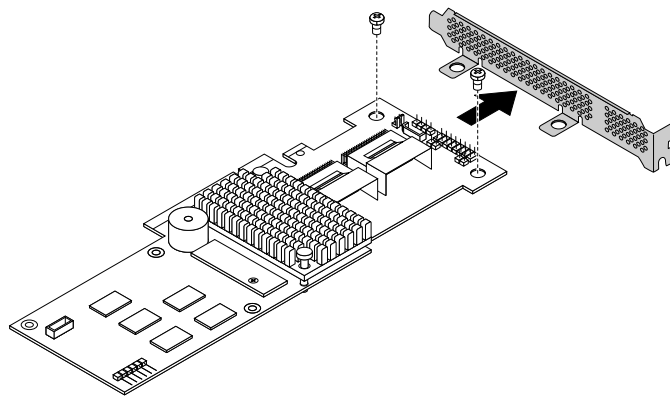

Figure 43. Removing the full-height bracket from the RAID card

9. Note the orientation of the low-profile bracket and position it on the RAID card. Align the two screw holes in the low-profile bracket with the corresponding screw holes in the RAID card and then install the screws to secure the bracket.

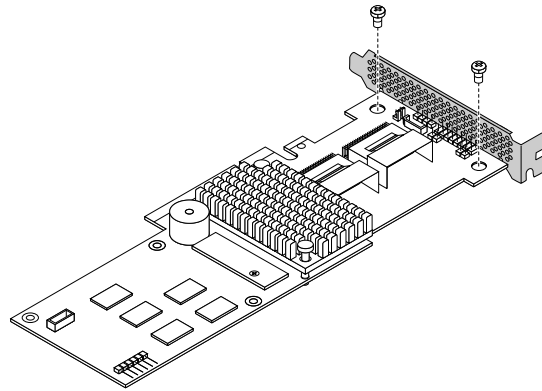

Figure 44. Installing the low-profile bracket to the RAID card

10. Position the RAID card near the PCI Express card slot. Ensure that the left edge of the RAID card is inserted into the notch of the RAID card retention bracket **1**. Then, carefully press the RAID card straight into the slot until it is securely seated and the low-profile bracket also is secured by the riser card assembly **2**.

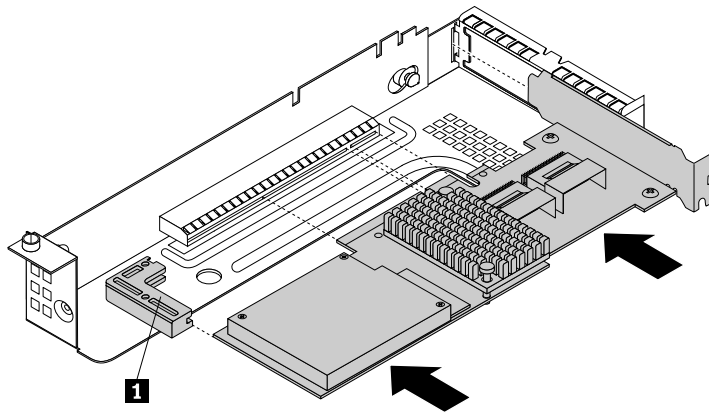

Figure 45. Installing the RAID card

11. Connect signal cables to the connectors on the new RAID card and the connectors on the hot-swap hard disk drive backplane. See “Mini-SAS to mini-SAS signal cable connections” on page 29.
12. Reinstall the riser card assembly **2**. The procedure is similar to that of the riser card assembly **1**. See “Replacing the riser card assembly **1**” on page 143.

What to do next:

- To work with another piece of hardware, go to the appropriate section.
- To complete the replacement, go to “Completing the parts replacement” on page 147. Then, configure RAID for your server. See “Configuring RAID” on page 56.

Removing the RAID card

Attention: Do not open your server or attempt any repair before reading and understanding “Safety information” on page iii and “Guidelines” on page 67.

This topic provides instructions on how to remove the RAID card. This topic applies only to models that have a RAID card installed.

Before you begin, print all the related instructions or ensure that you can view the PDF version on another computer for reference.

Notes:

- Use any documentation that comes with the RAID card and follow those instructions in addition to the instructions in this topic.
- Depending on the specific type, the RAID card might look different from the illustration in this topic.
- If you remove the RAID card, you will lose the advanced SATA/SAS hardware RAID functions.
- Ensure that you back up your data before removing the RAID card because you might need to reconfigure RAID and reinstall the operating system after removing the RAID card.

To remove the RAID card, do the following:

1. Remove all media from the drives and turn off all attached devices and the server. Then, disconnect all power cords from electrical outlets and disconnect all cables that are connected to the server.
2. If the server is installed in a rack cabinet, remove the server from the rack cabinet and place it on a flat, clean, and static-protective surface. See the *Rack Installation Instructions* that comes with the server.
3. Remove the server cover. See “Removing the server cover” on page 69.
4. Remove the cooling shroud. See “Removing and reinstalling the cooling shroud” on page 73.
5. Remove the riser card assembly 2 and lay it upside down on a flat, clean, and static-protective surface. The procedure is similar to that of the riser card assembly 1. See “Replacing the riser card assembly 1” on page 143.
6. Locate the RAID card, which is installed in the PCI Express card slot on the riser card assembly 2.
7. Disconnect all cables from the RAID card and any other related parts.

8. Grasp the RAID card by its edges and gently slide the RAID card out of the RAID card retention bracket and the riser card assembly 2.

Note: The RAID card might fit tightly into the PCI Express card slot. If necessary, alternate moving each side of the RAID card a small and equal amount until it is completely removed from the slot.

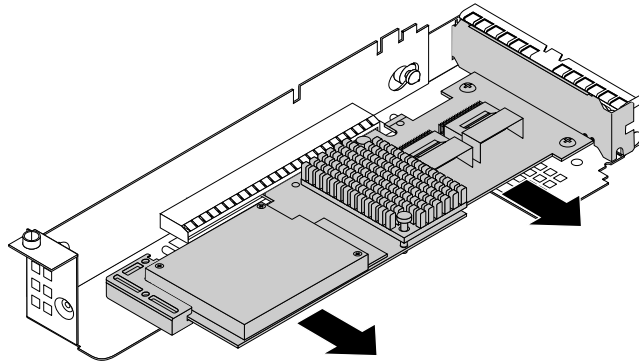

Figure 46. Removing the RAID card

9. Depending on your needs, do one of the following:
 - Install a new RAID card to replace the old one and reconnect cables. See “Installing the RAID card” on page 85.
 - Install a PCI Express card slot bracket to cover the place and connect related cables to the system board and the backplane. See “Mini-SAS to mini-SAS signal cable connections” on page 29.
10. Reinstall the riser card assembly 2. The procedure is similar to that of the riser card assembly 1. See “Replacing the riser card assembly 1” on page 143.
11. If you are instructed to return the old RAID card, follow all packaging instructions and use any packaging materials that are supplied to you for shipping.

What to do next:

- To work with another piece of hardware, go to the appropriate section.
- To complete the removal procedure, go to “Completing the parts replacement” on page 147. Then, you need to reconfigure RAID for your server. See “Configuring RAID” on page 56.

Installing or removing the ThinkServer RAID 500 Upgrade Key for Advanced RAID

This topic provides instructions on how to install or remove the ThinkServer RAID 500 Upgrade Key for Advanced RAID (hereinafter referred to as the TR 500 Key).

The TR 500 Key expands the capability of the installed ThinkServer RAID 500 Adapter by activating RAID 5 and RAID 50 levels for advanced SATA/SAS hardware RAID. You can purchase a TR 500 Key from Lenovo.

Installing the TR 500 Key

Attention: Do not open your server or attempt any repair before reading and understanding “Safety information” on page iii and “Guidelines” on page 67.

This topic provides instructions on how to install the TR 500 Key on a ThinkServer RAID 500 Adapter if your server has a ThinkServer RAID 500 Adapter installed.

Attention: Back up your data before you begin if you want to reconfigure RAID and reinstall the operating system after installing the TR 500 Key.

Before you begin, print all the related instructions or ensure that you can view the PDF version on another computer for reference.

Note: Use any documentation that comes with the TR 500 Key and follow those instructions in addition to the instructions in this topic.

To install the TR 500 Key, do the following:

1. Remove all media from the drives and turn off all attached devices and the server. Then, disconnect all power cords from electrical outlets and disconnect all cables that are connected to the server.
2. If the server is installed in a rack cabinet, remove the server from the rack cabinet and place it on a flat, clean, and static-protective surface. See the *Rack Installation Instructions* that comes with the server.
3. Remove the server cover. See “Removing the server cover” on page 69.
4. Remove the cooling shroud. See “Removing and reinstalling the cooling shroud” on page 73.
5. Locate the ThinkServer RAID 500 Adapter, which is installed in the PCI Express card slot on the riser card assembly 2. Then, disconnect any cables from the ThinkServer RAID 500 Adapter.
6. Remove the riser card assembly 2 and lay it upside down on a flat, clean, and static-protective surface. The procedure is similar to that of the riser card assembly 1. See “Replacing the riser card assembly 1” on page 143.
7. Touch the static-protective package that contains the TR 500 Key to any unpainted surface on the outside of the server. Then, take the TR 500 Key out of the package.

Note: Carefully handle the TR 500 Key by its edges.

8. Locate the TR 500 Key connector on the ThinkServer RAID 500 Adapter and then insert the TR 500 Key into the connector. You might need to remove the ThinkServer RAID 500 Adapter first, install the TR 500 Key on the ThinkServer RAID 500 Adapter, and then reinstall the ThinkServer RAID 500 Adapter. See “Installing or removing the RAID card” on page 85.

Note: Ensure that the TR 500 Key is securely seated on the ThinkServer RAID 500 Adapter.

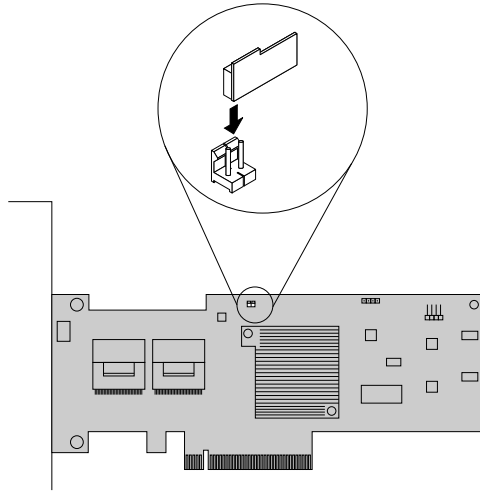

Figure 47. Installing the TR 500 Key

9. Reconnect cables to the ThinkServer RAID 500 Adapter. See “Mini-SAS to mini-SAS signal cable connections” on page 29.
10. Reinstall the riser card assembly 2. The procedure is similar to that of the riser card assembly 1. See “Replacing the riser card assembly 1” on page 143.

What to do next:

- To work with another piece of hardware, go to the appropriate section.
- To complete the installation, go to “Completing the parts replacement” on page 147. Then, the hardware RAID 5 and RAID 50 levels are available for your server if your server has the required number of hard disk drives installed. Refer to the *MegaRAID SAS Software User Guide* on the documentation DVD that comes with your server for information about how to configure the hardware RAID.

Removing the TR 500 Key

Attention: Do not open your server or attempt any repair before reading and understanding “Safety information” on page iii and “Guidelines” on page 67.

This topic provides instructions on how to remove the TR 500 Key from a ThinkServer RAID 500 Adapter if your server has a ThinkServer RAID 500 Adapter with a TR 500 Key option installed.

Attention: Back up your data before you begin if you need to reconfigure RAID and reinstall the operating system after removing the TR 500 Key.

Before you begin, print all the related instructions or ensure that you can view the PDF version on another computer for reference.

Notes:

- If you remove the TR 500 Key from the ThinkServer RAID 500 Adapter, the hardware RAID 5 and RAID 50 levels will be disabled.
- Use any documentation that comes with the TR 500 Key and follow those instructions in addition to the instructions in this topic.

To remove the TR 500 Key, do the following:

1. Remove all media from the drives and turn off all attached devices and the server. Then, disconnect all power cords from electrical outlets and disconnect all cables that are connected to the server.
2. If the server is installed in a rack cabinet, remove the server from the rack cabinet and place it on a flat, clean, and static-protective surface. See the *Rack Installation Instructions* that comes with the server.
3. Remove the server cover. See “Removing the server cover” on page 69.
4. Remove the cooling shroud. See “Removing and reinstalling the cooling shroud” on page 73.
5. Locate the ThinkServer RAID 500 Adapter, which is installed in the PCI Express card slot on the riser card assembly 2. Then, disconnect all cables from the ThinkServer RAID 500 Adapter.
6. Remove the riser card assembly 2. The procedure is similar to that of the riser card assembly 1. See “Replacing the riser card assembly 1” on page 143.
7. Locate the TR 500 Key on the ThinkServer RAID 500 Adapter and then remove it from the ThinkServer RAID 500 Adapter. You might need to remove the ThinkServer RAID 500 Adapter first, remove the TR 500 Key from the ThinkServer RAID 500 Adapter, and then reinstall the ThinkServer RAID 500 Adapter. See “Installing or removing the RAID card” on page 85.

Note: Carefully handle the TR 500 Key by its edges.

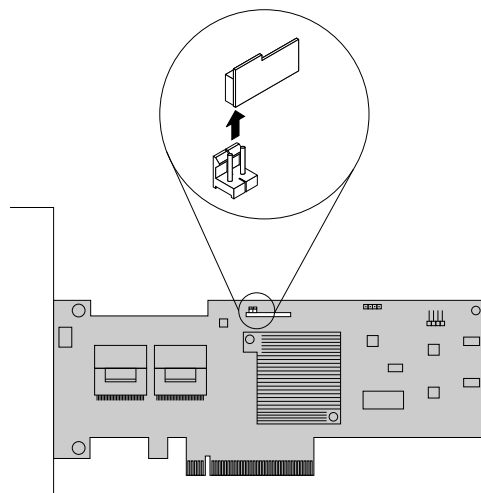

Figure 48. Removing the TR 500 Key

8. Reconnect cables to the ThinkServer RAID 500 Adapter. See “Mini-SAS to mini-SAS signal cable connections” on page 29.
9. Reinstall the riser card assembly 2. The procedure is similar to that of the riser card assembly 1. See “Replacing the riser card assembly 1” on page 143.
10. If you are instructed to return the old TR 500 Key, follow all packaging instructions and use any packaging materials that are supplied to you for shipping.

What to do next:

- To work with another piece of hardware, go to the appropriate section.

- To complete the removal procedure, go to “Completing the parts replacement” on page 147. As the hardware RAID 5 and 50 levels are not available without the TR 500 Key, you might need to reconfigure RAID for your server. Refer to the *MegaRAID SAS Software User Guide* on the documentation DVD that comes with your server for information about how to configure the hardware RAID.

Installing or removing the ThinkServer RAID 700 Battery

This topic provides instructions on how to install or remove the ThinkServer RAID 700 Battery (also known as the ThinkServer 9260-8i Battery and hereinafter referred to as the TR 700 Battery).

The TR 700 Battery protects the integrity of the cached data on the ThinkServer RAID 700 Adapter by providing backup power up to 72 hours in the case of a complete ac power failure or a brief power outage. It has built-in functionality to automatically charge the battery pack and to communicate battery status information (such as voltage, temperature, and current) to your server. It also provides an inexpensive alternative to using an uninterruptible power supply, and a second level of fault tolerance when used in conjunction with an uninterruptible power supply.

The temperature of the TR 700 Battery is generally 15-20°C (59-68°F) higher than the ambient temperature during fast charge. Therefore, to complete a recharge cycle, the ambient temperature should be lower than 55°C (131°F). If the ambient temperature exceeds 55°C (131°F), the recharge cycle will terminate prematurely, thus preventing the TR 700 Battery from reaching a fully charged state. A recharge cycle lasts at least six hours under normal operating conditions.

Attention: It is recommended that you replace the TR 700 Battery annually or after 500 recharging cycles, whichever comes first.

Installing the ThinkServer RAID 700 Battery

<p>Attention: Do not open your server or attempt any repair before reading and understanding “Safety information” on page iii and “Guidelines” on page 67.</p>

This topic provides instructions on how to install the TR 700 Battery on a ThinkServer RAID 700 Adapter if your server has a ThinkServer RAID 700 Adapter installed.

Before you begin, print all the related instructions or ensure that you can view the PDF version on another computer for reference.

Note: Use any documentation that comes with the TR 700 Battery and follow those instructions in addition to the instructions in this topic.

To install the TR 700 Battery, do the following:

1. Remove all media from the drives and turn off all attached devices and the server. Then, disconnect all power cords from electrical outlets and disconnect all cables that are connected to the server.
2. If the server is installed in a rack cabinet, remove the server from the rack cabinet and place it on a flat, clean, and static-protective surface. See the *Rack Installation Instructions* that comes with the server.
3. Remove the server cover. See “Removing the server cover” on page 69.
4. Remove the cooling shroud. See “Removing and reinstalling the cooling shroud” on page 73.
5. Locate the ThinkServer RAID 700 Adapter, which is installed in the PCI Express card slot on the riser card assembly 2. Then, disconnect all cables from the ThinkServer RAID 700 Adapter.
6. Remove the riser card assembly 2. The procedure is similar to that of the riser card assembly 1. See “Replacing the riser card assembly 1” on page 143.
7. Remove the ThinkServer RAID 700 Adapter from the riser card assembly 2. See “Installing or removing the RAID card” on page 85.

Note: Carefully handle the ThinkServer RAID 700 Adapter by its edges and place it on a flat, clean, and static-protective surface after you remove it.

8. Touch the static-protective package that contains the TR 700 Battery to any unpainted surface on the outside of the server. Then, take the TR 700 Battery out of the package.
9. Hold the TR 700 Battery with the battery side up and the board-to-board connector **1** on the bottom of the TR 700 Battery lining up with the connector **2** on the ThinkServer RAID 700 Adapter. Carefully install the TR 700 Battery onto the ThinkServer RAID 700 Adapter so that the two connectors are firmly joined. Then, install the three screws that come with the TR 700 Battery option kit to secure the TR 700 Battery in place.

Notes:

- Center the screwdriver when you install the screws and do not over-tighten the screws to avoid possible damage to any parts.
- Do not touch the board on the bottom of the TR 700 Battery.

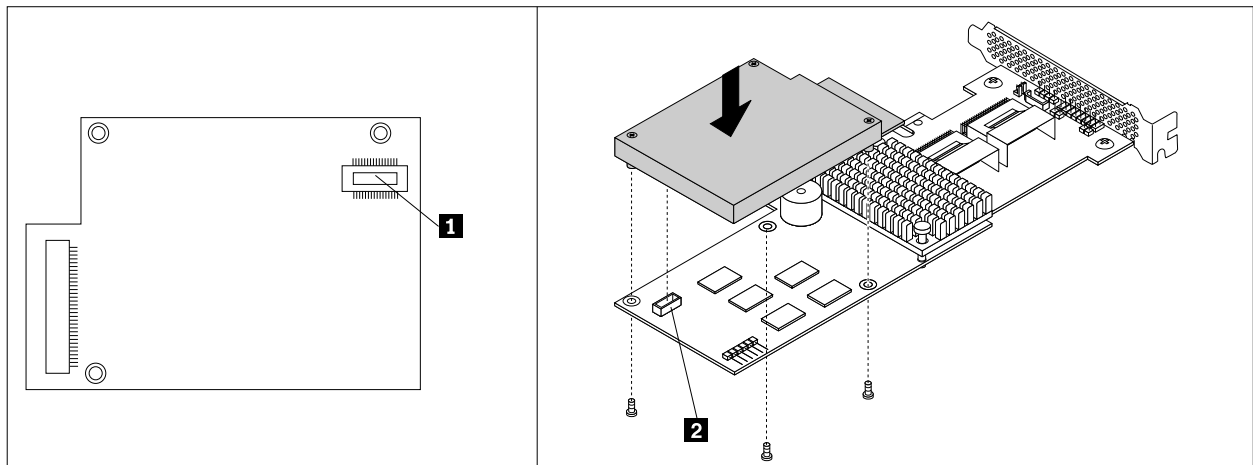

Figure 49. Installing the TR 700 Battery

10. Reinstall the ThinkServer RAID 700 Adapter with the TR 700 Battery to the riser card assembly 2. See “Installing or removing the RAID card” on page 85.
11. Reconnect cables to the ThinkServer RAID 700 Adapter. See “Mini-SAS to mini-SAS signal cable connections” on page 29.
12. Reinstall the riser card assembly 2. The procedure is similar to that of the riser card assembly 1. See “Replacing the riser card assembly 1” on page 143.

What to do next:

- To work with another piece of hardware, go to the appropriate section.
- To complete the installation, go to “Completing the parts replacement” on page 147. Then, configure RAID for your server. See “Configuring RAID” on page 56.

Removing the ThinkServer RAID 700 Battery

Attention: Do not open your server or attempt any repair before reading and understanding “Safety information” on page iii and “Guidelines” on page 67.

This topic provides instructions on how to remove the TR 700 Battery from a ThinkServer RAID 700 Adapter if your server has a ThinkServer RAID 700 Adapter with a TR 700 Battery installed.

Before you begin, print all the related instructions or ensure that you can view the PDF version on another computer for reference.

Notes:

- If you remove the TR 700 Battery, you will lose the backup power for the ThinkServer RAID 700 Adapter.
- Use any documentation that comes with the TR 700 Battery and follow those instructions in addition to the instructions in this topic.

To remove the TR 700 Battery, do the following:

1. Remove all media from the drives and turn off all attached devices and the server. Then, disconnect all power cords from electrical outlets and disconnect all cables that are connected to the server.
2. If the server is installed in a rack cabinet, remove the server from the rack cabinet and place it on a flat, clean, and static-protective surface. See the *Rack Installation Instructions* that comes with the server.
3. Remove the server cover. See “Removing the server cover” on page 69.
4. Remove the cooling shroud. See “Removing and reinstalling the cooling shroud” on page 73.
5. Locate the ThinkServer RAID 700 Adapter, which is installed in the PCI Express card slot on the riser card assembly 2. Then, disconnect all cables from the ThinkServer RAID 700 Adapter.
6. Remove the riser card assembly 2. The procedure is similar to that of the riser card assembly 1. See “Replacing the riser card assembly 1” on page 143.
7. Remove the ThinkServer RAID 700 Adapter from the riser card assembly 2. See “Installing or removing the RAID card” on page 85.
8. Remove the three screws first. Then, hold the TR 700 Battery and lift it up from the ThinkServer RAID 700 Adapter.

Note: Center the screwdriver when you remove the screws to avoid possible damage to any parts.

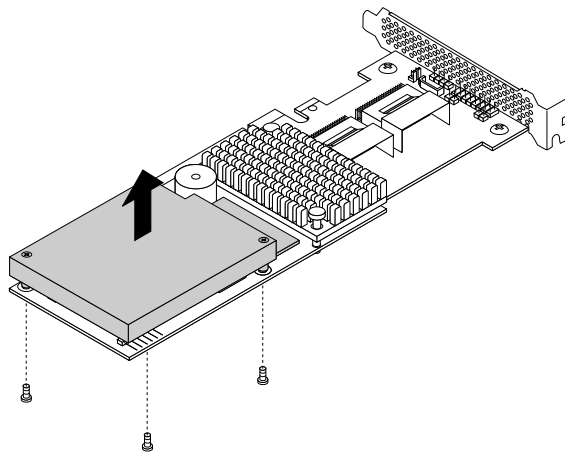

Figure 50. Removing the TR 700 Battery

9. Reinstall the ThinkServer RAID 700 Adapter to the riser card assembly 2. See “Installing or removing the RAID card” on page 85.
10. Reconnect cables to the ThinkServer RAID 700 Adapter. See “Mini-SAS to mini-SAS signal cable connections” on page 29.
11. Reinstall the riser card assembly 2. The procedure is similar to that of the riser card assembly 1. See “Replacing the riser card assembly 1” on page 143.

What to do next:

- To work with another piece of hardware, go to the appropriate section.
- To complete the removal procedure, go to “Completing the parts replacement” on page 147. Then, configure RAID for your server. See “Configuring RAID” on page 56.

Installing or removing the ThinkServer RAID 300 Upgrade Key for Advanced RAID

This topic provides instructions on how to install or remove the ThinkServer RAID 300 Upgrade Key for Advanced RAID (hereinafter referred to as the TR 300 Key).

The TR 300 Key expands the capability of the system board by activating RAID 5 for the onboard SAS software RAID. You can purchase a TR 300 Key from Lenovo.

Installing the TR 300 Key

Attention: Do not open your server or attempt any repair before reading and understanding “Safety information” on page iii and “Guidelines” on page 67.

This topic provides instructions on how to install the TR 300 Key.

Before you begin, print all the related instructions or ensure that you can view the PDF version on another computer for reference.

Notes:

- Use any documentation that comes with the TR 300 Key and follow those instructions in addition to the instructions in this topic.
- Depending on the model, your server might look slightly different from the illustration in this topic.

To install the TR 300 Key, do the following:

1. Remove all media from the drives and turn off all attached devices and the server. Then, disconnect all power cords from electrical outlets and disconnect all cables that are connected to the server.
2. If the server is installed in a rack cabinet, remove the server from the rack cabinet and place it on a flat, clean, and static-protective surface. See the *Rack Installation Instructions* that comes with the server.
3. Remove the server cover. See “Removing the server cover” on page 69.
4. Locate the iButton socket on the system board. See “System board components” on page 31. If there is any PCI Express card installed on the riser card assembly 1, it might block your access to the iButton socket on the system board. In this case, you need to remove the cooling shroud and then carefully lift the riser card assembly 1 up so that you can access the iButton socket. You do not need to disconnect any cables from the PCI Express card or completely remove the riser card assembly 1.
5. Touch the static-protective package that contains the TR 300 Key to any unpainted surface on the outside of the server. Then, take the TR 300 Key out of the package.

6. Insert one side of the TR 300 Key under one of the retaining clips on the iButton socket. Then, carefully press the other side of the TR 300 Key straight down until the key snaps into position and is secured by the two retaining clips on the iButton socket.

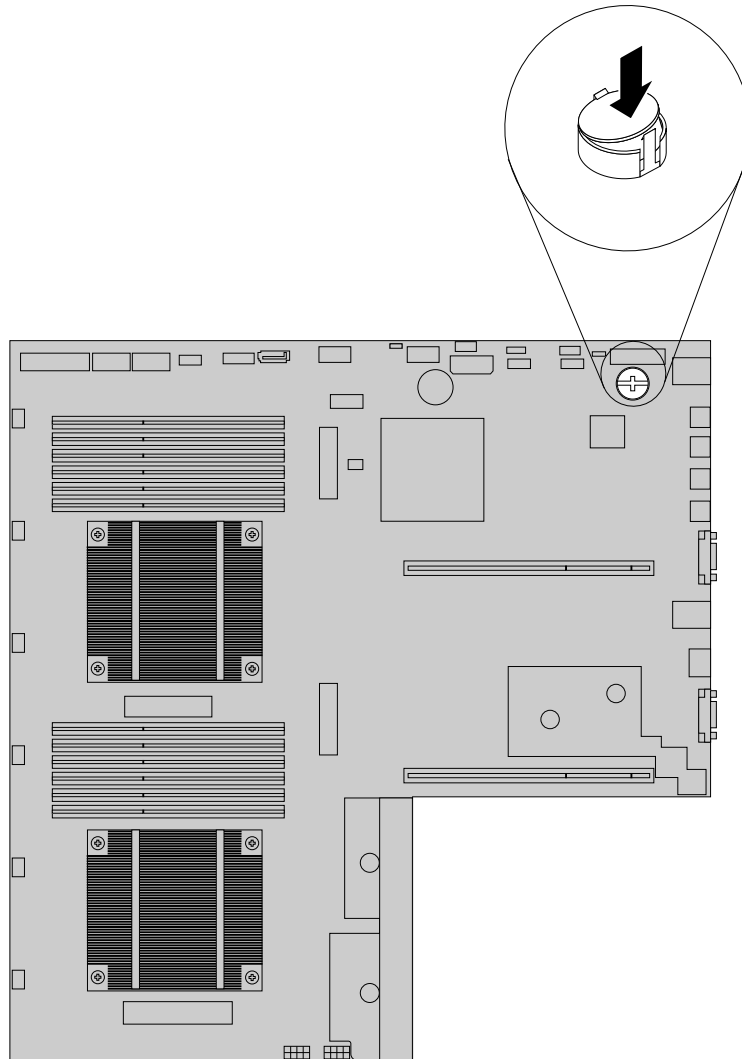

Figure 51. Installing the TR 300 Key

7. If you have lifted up the riser card assembly 1, reinstall it into the chassis. See “Replacing the riser card assembly 1” on page 143.

What to do next:

- To work with another piece of hardware, go to the appropriate section.
- To complete the installation, go to “Completing the parts replacement” on page 147. Then, the onboard SAS software RAID 5 is available for your server if your server has the required number of hard disk drives installed. To configure RAID, see “Configuring RAID” on page 56.

Removing the TR 300 Key

Attention: Do not open your server or attempt any repair before reading and understanding “Safety information” on page iii and “Guidelines” on page 67.

This topic provides instructions on how to remove the TR 300 Key if your server has a TR 300 Key installed.

Notes:

- If you remove the TR 300 Key, the onboard SAS software RAID 5 will be disabled.
- Use any documentation that comes with the TR 300 Key and follow those instructions in addition to the instructions in this topic.
- Depending on the model, your server might look slightly different from the illustration in this topic.

Before you begin, print all the related instructions or ensure that you can view the PDF version on another computer for reference.

To remove the TR 300 Key, do the following:

1. Remove all media from the drives and turn off all attached devices and the server. Then, disconnect all power cords from electrical outlets and disconnect all cables that are connected to the server.
2. If the server is installed in a rack cabinet, remove the server from the rack cabinet and place it on a flat, clean, and static-protective surface. See the *Rack Installation Instructions* that comes with the server.
3. Remove the server cover. See “Removing the server cover” on page 69.
4. Locate the iButton socket on the system board. See “System board components” on page 31. If there is any PCI Express card installed on the riser card assembly 1, it might block your access to the iButton socket on the system board. In this case, you need to remove the cooling shroud and then carefully lift the riser card assembly 1 up so that you can access the iButton socket. You do not need to disconnect any cables from the PCI Express card or completely remove the riser card assembly 1.

5. Open the retaining clip **1** on the iButton socket to release the TR 300 Key and then completely remove the key from the iButton socket.

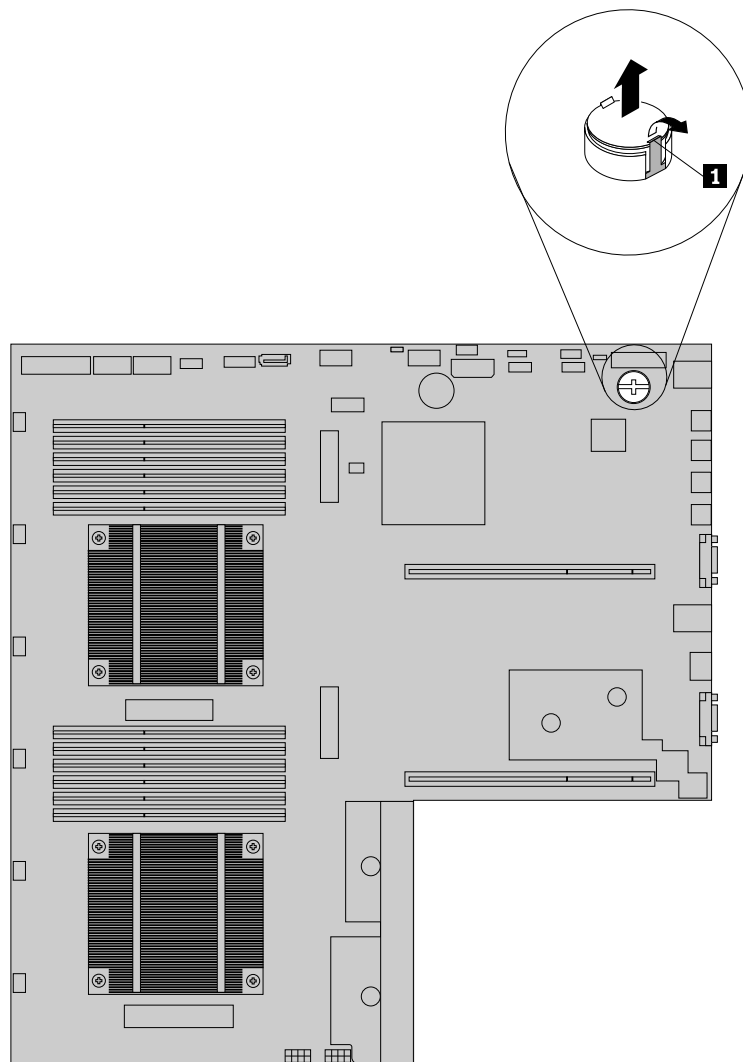

Figure 52. Removing the TR 300 Key

6. If you have lifted up the riser card assembly 1, reinstall it into the chassis. See “Replacing the riser card assembly 1” on page 143.
7. If you are instructed to return the old TR 300 Key, follow all packaging instructions and use any packaging materials that are supplied to you for shipping.

What to do next:

- To work with another piece of hardware, go to the appropriate section.
- To complete the removal procedure, go to “Completing the parts replacement” on page 147. As the onboard SAS software RAID 5 is not available without the TR 300 Key, you might need to reconfigure RAID for your server. See “Configuring RAID” on page 56.

Installing or removing the ThinkServer Management Module Premium

This topic provides instructions on how to install or remove the ThinkServer Management Module Premium (hereinafter referred to as the TMM Premium).

The TMM Premium offers convenient, remote KVM access and control through the LAN or Internet. You can use the TMM Premium to gain location-independent remote access to respond to critical incidents and to undertake necessary maintenance. Therefore, working as an integrated solution in your server, the TMM Premium provides an increased level of manageability over the basic server management. You can purchase a TMM Premium from Lenovo.

Installing the TMM Premium

Attention: Do not open your server or attempt any repair before reading and understanding “Safety information” on page iii and “Guidelines” on page 67.

This topic provides instructions on how to install the TMM Premium.

Before you begin, print all the related instructions or ensure that you can view the PDF version on another computer for reference.

Notes:

- Use any documentation that comes with the TMM Premium and follow those instructions in addition to the instructions in this topic.
- Depending on the model, your server might look slightly different from the illustration in this topic.

To install the TMM Premium, do the following:

1. Remove all media from the drives and turn off all attached devices and the server. Then, disconnect all power cords from electrical outlets and disconnect all cables that are connected to the server.
2. If the server is installed in a rack cabinet, remove the server from the rack cabinet and place it on a flat, clean, and static-protective surface. See the *Rack Installation Instructions* that comes with the server.
3. Remove the server cover. See “Removing the server cover” on page 69.
4. Touch the static-protective package that contains the TMM Premium to any unpainted surface on the outside of the server. Then, take the TMM Premium out of the package.

5. Locate the TMM Premium connector on the system board and then insert the TMM Premium into the TMM Premium connector.

Note: Ensure that the TMM Premium is securely seated on the system board.

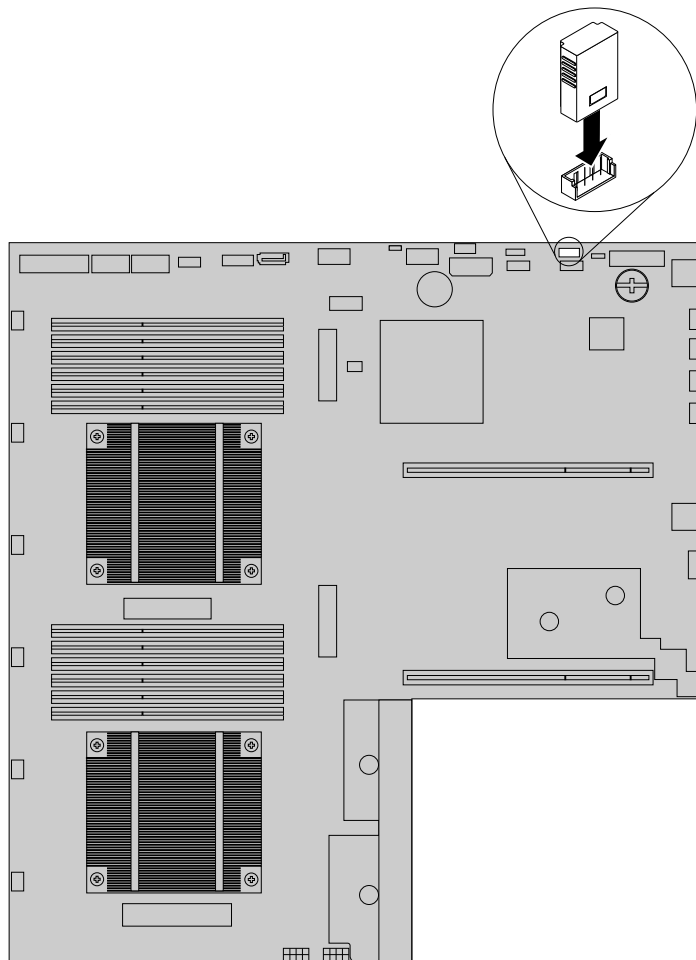

Figure 53. Installing the TMM Premium

What to do next:

- To work with another piece of hardware, go to the appropriate section.
- To complete the installation, go to “Completing the parts replacement” on page 147. Then, refer to the *ThinkServer Management Module User Guide*, which is available for download at <http://www.lenovo.com/ThinkServerUserGuides>, for more information about server remote management.

Removing the TMM Premium

Attention: Do not open your server or attempt any repair before reading and understanding “Safety information” on page iii and “Guidelines” on page 67.

This topic provides instructions on how to remove the TMM Premium if the server has one installed.

Before you begin, print all the related instructions or ensure that you can view the PDF version on another computer for reference.

Notes:

- Use any documentation that comes with the TMM Premium and follow those instructions in addition to the instructions in this topic.
- If you remove the TMM Premium, the iKVM function for server remote management will be unavailable.
- Depending on the model, your server might look slightly different from the illustration in this topic.

To remove the TMM Premium, do the following:

1. Remove all media from the drives and turn off all attached devices and the server. Then, disconnect all power cords from electrical outlets and disconnect all cables that are connected to the server.
2. If the server is installed in a rack cabinet, remove the server from the rack cabinet and place it on a flat, clean, and static-protective surface. See the *Rack Installation Instructions* that comes with the server.
3. Remove the server cover. See “Removing the server cover” on page 69.
4. Locate the TMM Premium on the system board and then lift the TMM Premium straight up to remove it from the connector.

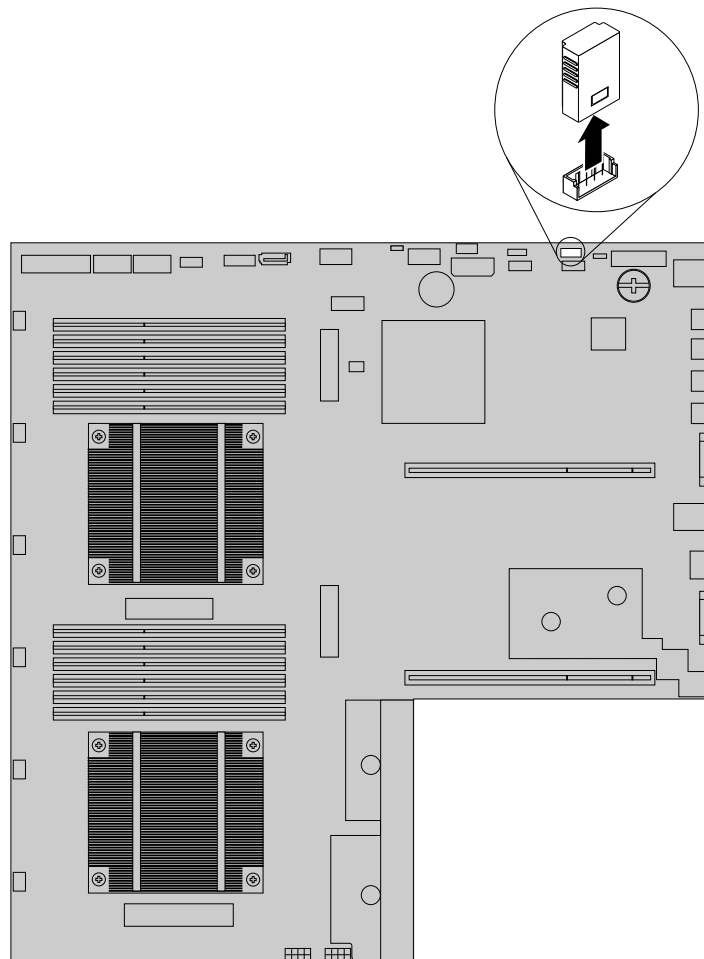

Figure 54. Removing the TMM Premium

5. If you are instructed to return the old TMM Premium, follow all packaging instructions and use any packaging materials that are supplied to you for shipping.

What to do next:

- To work with another piece of hardware, go to the appropriate section.
- To complete the removal procedure, go to “Completing the parts replacement” on page 147.

Installing or removing the ThinkServer Trusted Platform Module

This topic provides instructions on how to install or remove the ThinkServer Trusted Platform Module (hereinafter referred to as the TPM).

The TPM is a security chip designed by the Trusted Computing Group (TCG) to provide a hardware method of data encryption. It stores passwords, encryption keys, and digital certificates to help provide security solutions and protect the computer. You can purchase a TPM option from Lenovo.

Installing the ThinkServer Trusted Platform Module

Attention: Do not open your server or attempt any repair before reading and understanding “Safety information” on page iii and “Guidelines” on page 67.

This topic provides instructions on how to install the TPM.

Before you begin, print all the related instructions or ensure that you can view the PDF version on another computer for reference.

Notes:

- Use any documentation that comes with the TPM and follow those instructions in addition to the instructions in this topic.
- Depending on the model, your server might look slightly different from the illustration in this topic.

To install the TPM, do the following:

1. Remove all media from the drives and turn off all attached devices and the server. Then, disconnect all power cords from electrical outlets and disconnect all cables that are connected to the server.
2. If the server is installed in a rack cabinet, remove the server from the rack cabinet and place it on a flat, clean, and static-protective surface. See the *Rack Installation Instructions* that comes with the server.
3. Remove the server cover. See “Removing the server cover” on page 69.
4. Locate the TPM connector on the system board. See “System board components” on page 31. If there is any PCI Express card installed on the riser card assembly 1, it might block your access to the TPM connector on the system board. In this case, you need to remove the cooling shroud and then carefully lift the riser card assembly 1 up so that you can access the TPM connector. You do not need to disconnect any cables from the PCI Express card or completely remove the riser card assembly 1.
5. Touch the static-protective package that contains the TPM to any unpainted surface on the outside of the server. Then, take the TPM out of the package.

Note: Carefully handle the TPM by its edges.

6. Insert the TPM into the TPM connector on the system board.

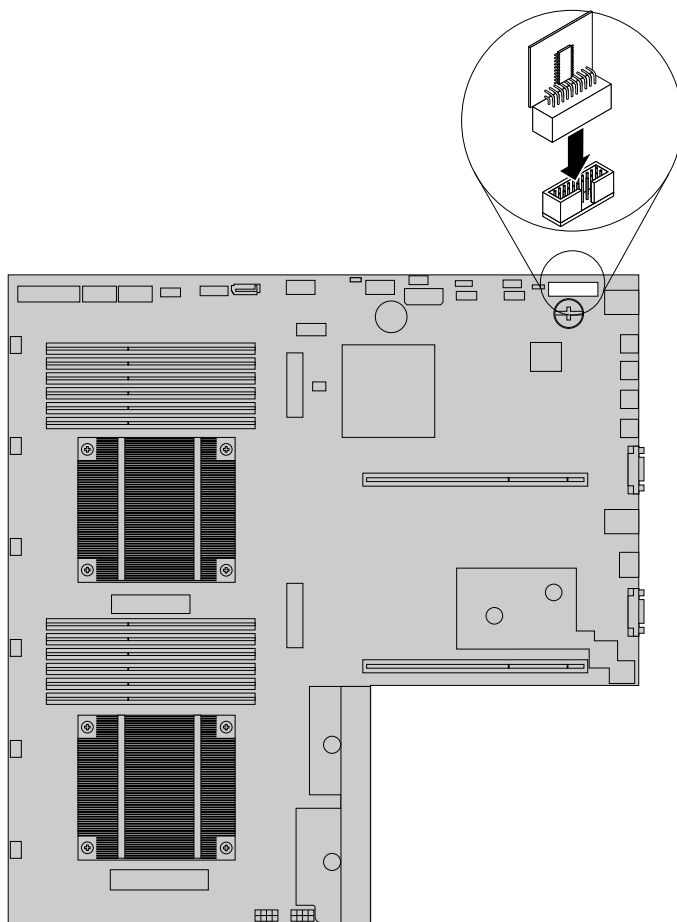

Figure 55. Installing the TPM

7. If you have lifted up the riser card assembly 1, reinstall it into the chassis. See “Replacing the riser card assembly 1” on page 143.

What to do next:

- To work with another piece of hardware, go to the appropriate section.
- To complete the installation, go to “Completing the parts replacement” on page 147. Then, you can configure the TPM function in the Setup Utility program. See “Configuring the TPM function” on page 50.

Removing the ThinkServer Trusted Platform Module

Attention: Do not open your server or attempt any repair before reading and understanding “Safety information” on page iii and “Guidelines” on page 67.

This topic provides instructions on how to remove the TPM if the server has one installed.

Before you begin, print all the related instructions or ensure that you can view the PDF version on another computer for reference.

Notes:

- If you remove the TPM, the TPM function will be unavailable.
- Use any documentation that comes with the TPM and follow those instructions in addition to the instructions in this topic.
- Depending on the model, your server might look slightly different from the illustration in this topic.

To remove the TPM, do the following:

1. Remove all media from the drives and turn off all attached devices and the server. Then, disconnect all power cords from electrical outlets and disconnect all cables that are connected to the server.
2. If the server is installed in a rack cabinet, remove the server from the rack cabinet and place it on a flat, clean, and static-protective surface. See the *Rack Installation Instructions* that comes with the server.
3. Remove the server cover. See “Removing the server cover” on page 69.
4. Locate the TPM on the system board. See “System board components” on page 31. If there is any PCI Express card installed on the riser card assembly 1, it might block your access to the TPM connector on the system board. In this case, you need to remove the cooling shroud and then carefully lift the riser card assembly 1 up so that you can access the TPM connector. You do not need to disconnect any cables from the PCI Express card or completely remove the riser card assembly 1.

5. Remove the TPM from the TPM connector by lifting it straight up.

Note: Carefully handle the TPM by its edges.

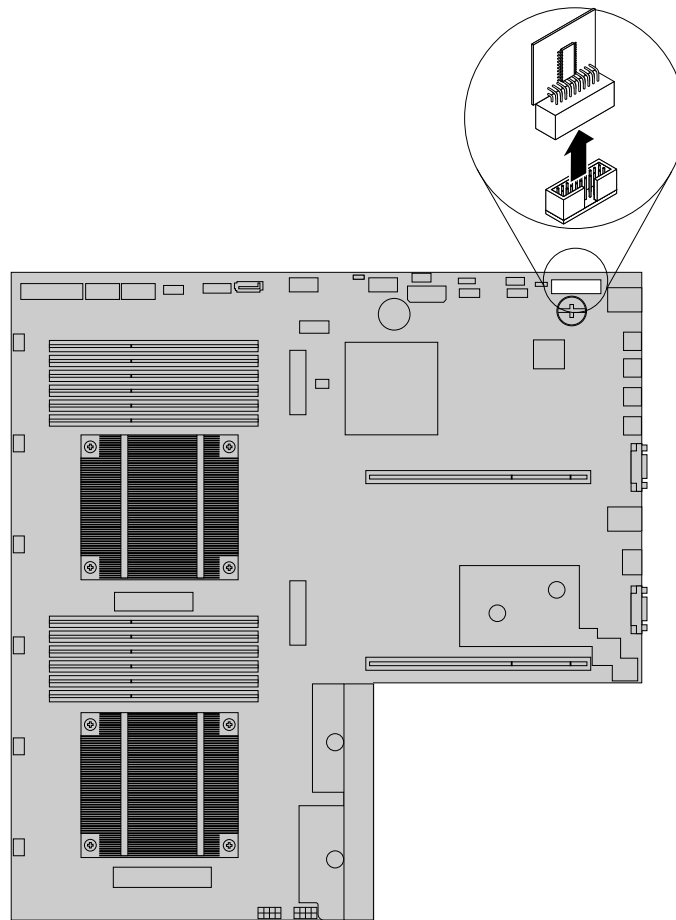

Figure 56. Removing the TPM

6. If you have lifted up the riser card assembly 1, reinstall it into the chassis. See “Replacing the riser card assembly 1” on page 143.
7. If you are instructed to return the old TPM, follow all packaging instructions and use any packaging materials that are supplied to you for shipping.

What to do next:

- To work with another piece of hardware, go to the appropriate section.
- To complete the removal procedure, go to “Completing the parts replacement” on page 147.

Installing or replacing a hot-swap redundant power supply

This topic provides instructions on how to install or replace a hot-swap redundant power supply.

On each hot-swap redundant power supply, there is a status LED near the power cord connector. When the LED is lit in green, it indicates that the hot-swap redundant power supply is working correctly. When the LED is lit in amber, it indicates that the hot-swap redundant power supply is likely to fail or has failed.

The hot-swap redundant power supply adds a second source of power to the server. When the server is populated with two hot-swap redundant power supplies, it can withstand a power loss from either power supply. This helps you avoid significant interruption to the operation of the system when a power supply fails. You can replace a hot-swap redundant power supply without turning off the server.

Note: To maintain the EMI integrity and cooling of the server, install a new hot-swap redundant power supply as soon as you remove the failing one or cover the other bay with a shield if you just use one module to provide power.

Some server models come with only one power supply. You can purchase a hot-swap redundant power supply option from Lenovo.

CAUTION:
Hazardous moving parts. Keep fingers and other body parts away.

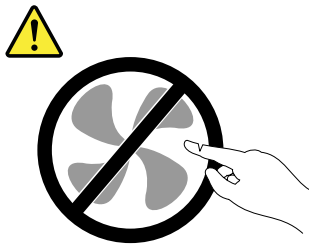

CAUTION:
Never remove the cover on a power supply or any part that has the following label attached.

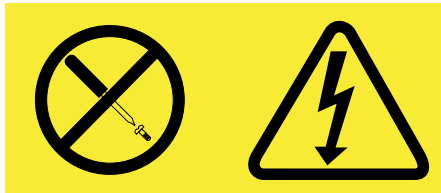

Hazardous voltage, current, and energy levels are present inside any component that has this label attached. There are no serviceable parts inside these components. If you suspect a problem with one of these parts, contact a service technician.

Installing a hot-swap redundant power supply

Attention: Do not open your server or attempt any repair before reading and understanding “Safety information” on page iii and “Guidelines” on page 67.

This topic provides instructions on how to install a hot-swap redundant power supply.

Before you begin, print all the related instructions or ensure that you can view the PDF version on another computer for reference.

Notes:

- Your hot-swap redundant power supply might look slightly different from the illustrations in this topic.
- Use any documentation that comes with the new hot-swap redundant power supply and follow those instructions in addition to the instructions in this topic.

To install a hot-swap redundant power supply, do the following:

1. Locate the bay for the power supply in the rear of your server. Insert a finger into the hole in the metal shield that protects the bay, press the tab **1** in the direction as shown, and then pull the shield out of the chassis. Store the shield in the event that you later remove the power supply and need the shield to cover the bay.

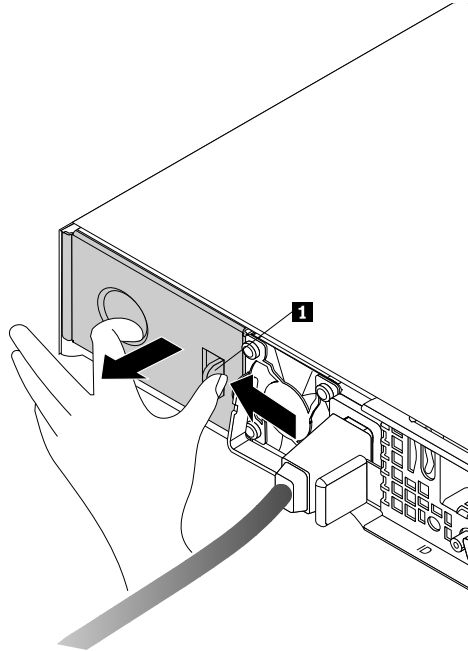

Figure 57. Removing the protective shield for the power supply bay

2. Touch the static-protective package that contains the new hot-swap redundant power supply to any unpainted surface on the outside of the server. Then, take the new hot-swap redundant power supply out of the package.

3. Note the orientation of the new hot-swap redundant power supply and then slide it into the chassis until it snaps into position.

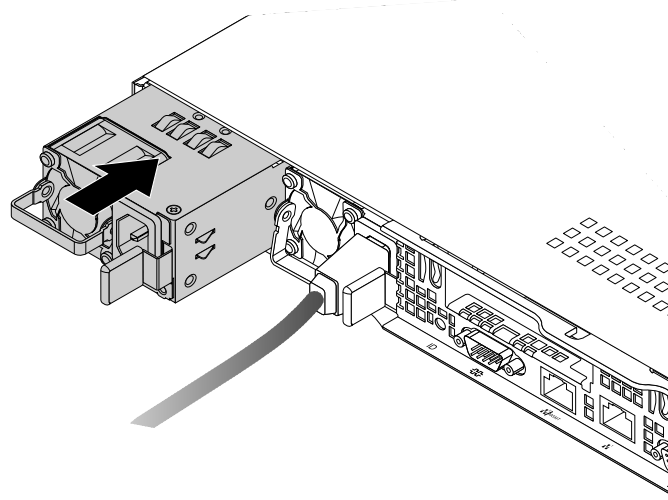

Figure 58. Installing a hot-swap redundant power supply

4. Connect the power cord to the power connector on the new hot-swap redundant power supply. Then, check the status LED near the power connector. When the LED is lit in green, it indicates that the hot-swap redundant power supply is working correctly. When the LED is lit in amber, it indicates that the hot-swap redundant power supply is likely to fail or has failed. Reinstall the new hot-swap redundant power supply to see if the problem can be solved. If the new hot-swap redundant power supply still does not work correctly, contact your place of purchase or a service representative for help.

Replacing a hot-swap redundant power supply

Attention: Do not open your server or attempt any repair before reading and understanding “Safety information” on page iii and “Guidelines” on page 67.

This topic provides instructions on how to replace a hot-swap redundant power supply.

Before you begin, print all the related instructions or ensure that you can view the PDF version on another computer for reference.

Notes:

- Your hot-swap redundant power supply might look slightly different from the illustrations in this topic.
- Use any documentation that comes with the hot-swap redundant power supply and follow those instructions in addition to the instructions in this topic.

To replace a hot-swap redundant power supply, do the following:

1. Locate the failing hot-swap redundant power supply in the rear of your server. Then, disconnect the power cord from the failing hot-swap redundant power supply.
2. Press the tab **1** in the direction as shown and carefully pull the handle **2** at the same time to slide the failing hot-swap redundant power supply out of the chassis.

Note: Do not use too much force. You can first carefully slide the hot-swap redundant power supply a little bit out to release it from the secured position. Then, completely slide it out of the chassis.

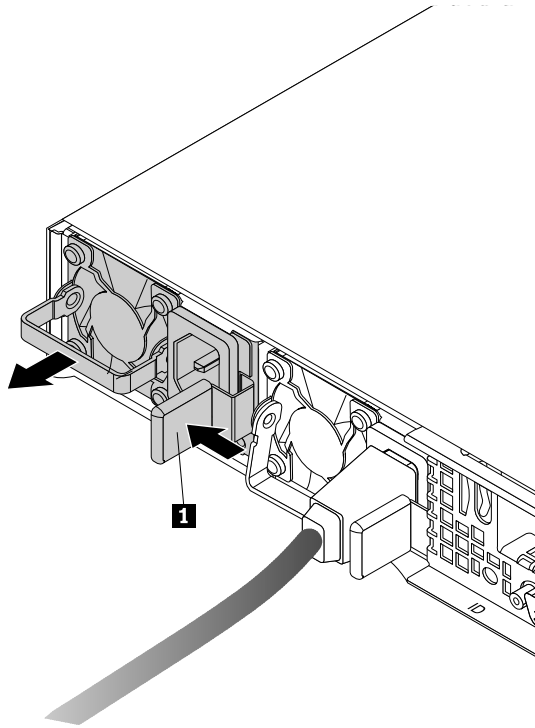

Figure 59. Removing a hot-swap redundant power supply

3. Install a new hot-swap redundant power supply to the bay. See “Installing a hot-swap redundant power supply” on page 107.
4. If you are instructed to return the old hot-swap redundant power supply, follow all packaging instructions and use any packaging materials that are supplied to you for shipping.

Installing or replacing a heat sink

Attention: Do not open your server or attempt any repair before reading and understanding “Safety information” on page iii and “Guidelines” on page 67.

This topic provides instructions on how to install or replace a heat sink.

CAUTION:

The heat sink might be very hot. Turn off the server and wait three to five minutes to let the server cool before removing the server cover.

Before you begin, print all the related instructions or ensure that you can view the PDF version on another computer for reference.

Notes:

- Use any documentation that comes with the heat sink and follow those instructions in addition to the instructions in this topic.
- Depending on the model, your server might look slightly different from the illustrations in this topic.

To install or replace a heat sink, do the following:

1. Remove all media from the drives and turn off all attached devices and the server. Then, disconnect all power cords from electrical outlets and disconnect all cables that are connected to the server.
2. If the server is installed in a rack cabinet, remove the server from the rack cabinet and place it on a flat, clean, and static-protective surface. See the *Rack Installation Instructions* that comes with the server.
3. Remove the server cover. See “Removing the server cover” on page 69.
4. Remove the cooling shroud. See “Removing and reinstalling the cooling shroud” on page 73.
5. Locate the heat sink or the place for installing the second heat sink. See “Server components” on page 22.

6. If you are replacing a heat sink, remove the four screws that secure the heat sink to the system board. It is recommended that you carefully remove the four screws from the system board using the following method to avoid any possible damage to the system board.
 - a. Partially remove screw **1**, then completely remove screw **3**, and then return to screw **1** and completely remove it.
 - b. Partially remove screw **2**, then completely remove screw **4**, and then return to screw **2** and completely remove it.

Note: The four screws are integrated parts of the heat sink. Do not try to remove the four screws from the heat sink.

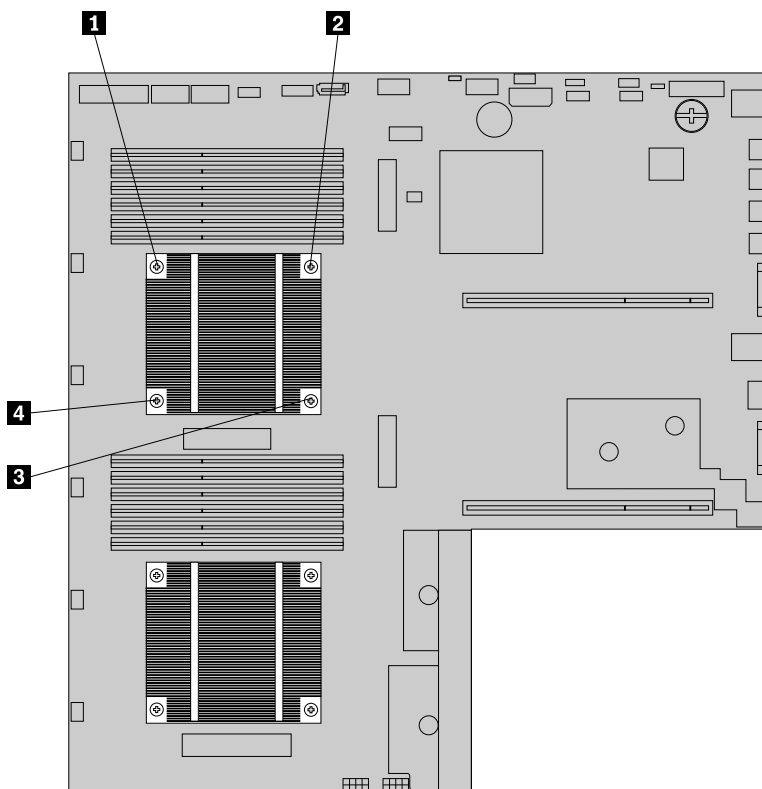

Figure 60. Removing the screws that secure the heat sink

7. Gently twist the heat sink to free it from the microprocessor and then lift the heat sink off the system board.
8. Lay aside the old heat sink. Touch the static-protective package that contains the new heat sink to any unpainted surface on the outside of the server. Then, take the new heat sink out of the package.

Notes:

- If you are replacing a heat sink, you need to use a cleaning pad that might come with the new heat sink to wipe the thermal grease from the top of the microprocessor before installing the new heat sink. Dispose of the cleaning pad after all of the thermal grease is removed from the microprocessor.
 - When handling the new heat sink, do not touch the thermal grease on the bottom of it.
9. Remove any protective cover that protects the thermal grease on the bottom of the new heat sink. Then, place the new heat sink on the system board so that the four screws on the new heat sink are aligned with the corresponding mounting studs on the system board.

10. Install the four screws to secure the new heat sink on the system board. It is recommended that you carefully install the four screws using the following method to avoid any possible damage to the system board.
 - a. Partially tighten screw **1**, then firmly tighten screw **3**, and then return to screw **1** and firmly tighten it. Do not over-tighten the screws.
 - b. Partially tighten screw **2**, then firmly tighten screw **4**, and then return to screw **2** and firmly tighten it. Do not over-tighten the screws.

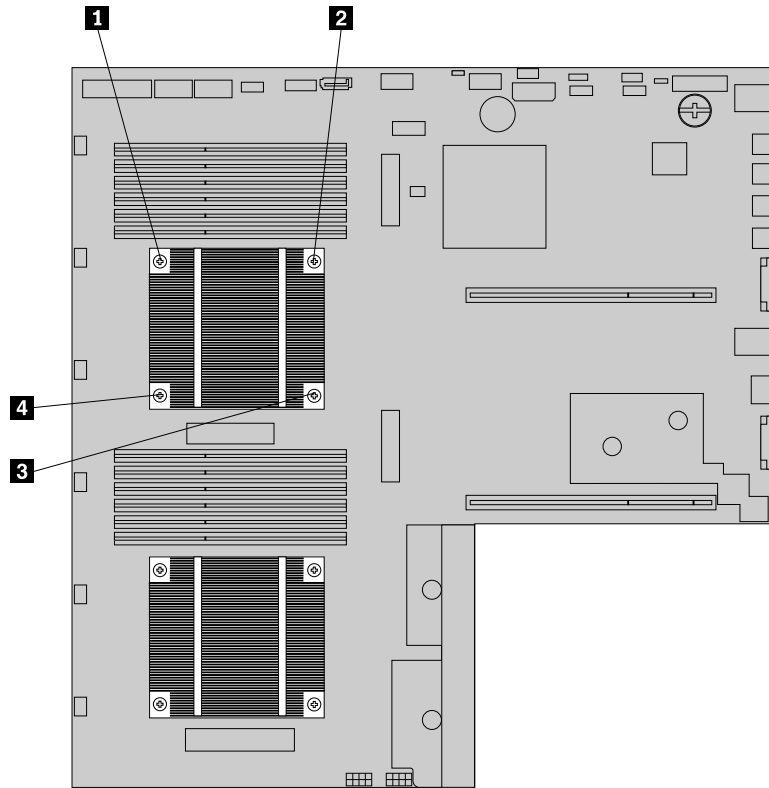

Figure 61. Installing the screws to secure the heat sink

11. If you are instructed to return the old heat sink, follow all packaging instructions and use any packaging materials that are supplied to you for shipping.

What to do next:

- To work with another piece of hardware, go to the appropriate section.
- To complete the installation or replacement, go to “Completing the parts replacement” on page 147.

Installing or replacing the microprocessor

This topic provides instructions on how to install or replace the microprocessor.

Installing the second microprocessor

Attention: Do not open your server or attempt any repair before reading and understanding “Safety information” on page iii and “Guidelines” on page 67.

This topic provides instructions on how to install the second microprocessor.

Depending on the model, your server might come with one or two microprocessors. For server models with one microprocessor, the microprocessor is installed in the microprocessor socket 1 and the microprocessor socket 2 is protected by a plastic socket cover. You can purchase a microprocessor option kit from Lenovo and install the second microprocessor to expand system capabilities.

CAUTION:



Turn off the server and wait three to five minutes to let the server cool before removing the server cover.

Before you begin, print all the related instructions or ensure that you can view the PDF version on another computer for reference.

Notes:

- Ensure that you install the correct type of microprocessor option your server supports. See “Memory module installation rules” on page 75. When two microprocessors are installed, both must have the same core voltage and core speed.
- Use any documentation that comes with the microprocessor option kit and follow those instructions in addition to the instructions in this topic.
- Your microprocessor, socket, and socket cover might look slightly different from the illustrations in this topic.

To install the second microprocessor, do the following:

1. Remove all media from the drives and turn off all attached devices and the server. Then, disconnect all power cords from electrical outlets and disconnect all cables that are connected to the server.
2. If the server is installed in a rack cabinet, remove the server from the rack cabinet and place it on a flat, clean, and static-protective surface. See the *Rack Installation Instructions* that comes with the server.
3. Remove the server cover. See “Removing the server cover” on page 69.
4. Remove the cooling shroud. See “Removing and reinstalling the cooling shroud” on page 73.
5. Locate the microprocessor socket 2 on the system board. See “System board components” on page 31.

6. Press down the small handle on the microprocessor socket and then pull the handle a little bit outward to release it from the secured position. Then, gently press the microprocessor retainer to open it. Ensure that the small handle and the microprocessor retainer are in the fully open position.

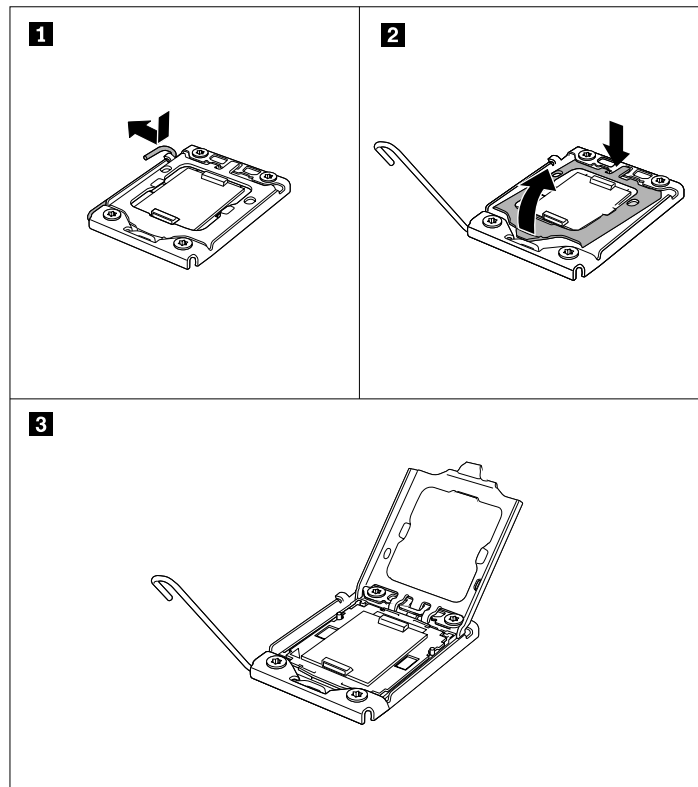

Figure 62. Opening the handle and microprocessor retainer

7. Touch the static-protective package that contains the new microprocessor to any unpainted surface on the outside of the server. Then, remove the new microprocessor from the package.

8. Remove the plastic microprocessor socket cover. Store the microprocessor socket cover in the event that you later remove the microprocessor and need the socket cover to protect the pins on the socket. Then, remove the protective cover that protects the gold contacts on the bottom of the new microprocessor.

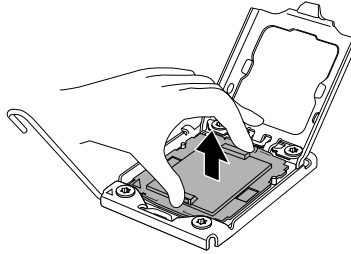

Figure 63. Removing the microprocessor socket cover

Notes:

- Do not remove the socket cover until you install a microprocessor into the socket. If you remove the microprocessor, install the socket cover or a new microprocessor immediately.
- Do not drop anything onto the microprocessor socket while it is exposed. The socket pins must be kept as clean as possible.
- Do not touch the pins on the microprocessor socket and the gold contacts on the bottom of the new microprocessor.

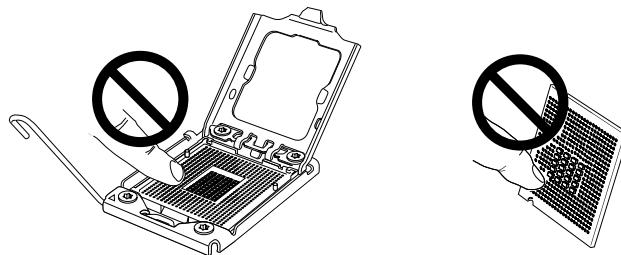

Figure 64. Do not touch the pins

9. Note the orientation of the new microprocessor. Hold the new microprocessor by its edges and align the notches **1** on it with the tabs **2** in the microprocessor socket. Then, carefully lower the new microprocessor straight down into the microprocessor socket.

Note: The small triangle **3** on one corner of the new microprocessor is the microprocessor orientation indicator. The new microprocessor is in the correct orientation when this indicator faces the beveled corner **4** of the microprocessor socket.

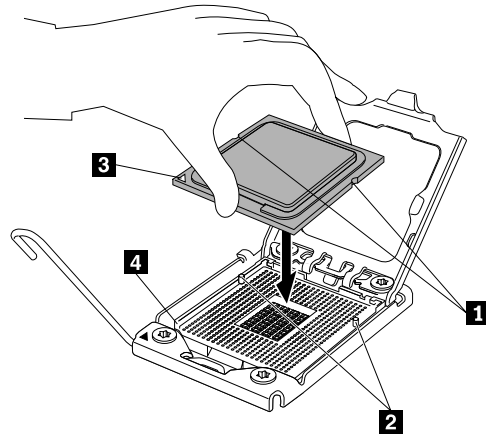

Figure 65. Installing the microprocessor

10. Gently close the microprocessor retainer, press down the small handle, and then push the handle inward to lock the retainer into position and secure the new microprocessor in the socket.

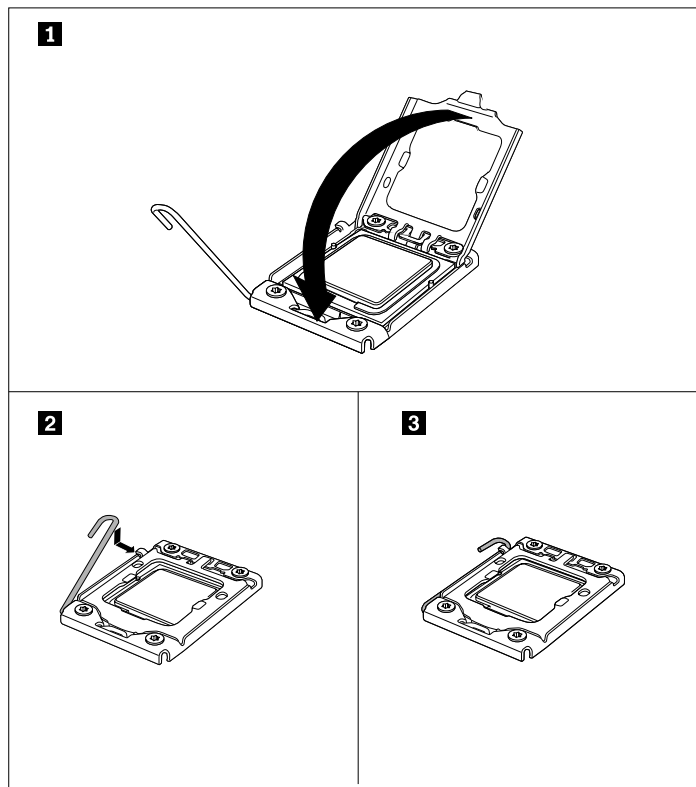

Figure 66. Securing the microprocessor in the socket

11. Install the new heat sink that comes with the microprocessor option kit. See “Installing or replacing a heat sink” on page 110.

What to do next:

- To work with another piece of hardware, go to the appropriate section.
- To complete the installation, go to “Completing the parts replacement” on page 147.

Replacing the microprocessor

Attention: Do not open your server or attempt any repair before reading and understanding “Safety information” on page iii and “Guidelines” on page 67.

This topic provides instructions on how to replace the microprocessor.

CAUTION:



The heat sink and microprocessor might be very hot. Turn off the server and wait three to five minutes to let the server cool before removing the server cover.

Before you begin, print all the related instructions or ensure that you can view the PDF version on another computer for reference.

Notes:

- Ensure that the new microprocessor is the correct type your server supports. See “Memory module installation rules” on page 75. When two microprocessors are installed, both must have the same core voltage and core speed.
- Use any documentation that comes with the microprocessor option kit and follow those instructions in addition to the instructions in this topic.
- Your microprocessor, socket, and socket cover might look slightly different from the illustrations in this topic.

To replace the microprocessor, do the following:

1. Remove all media from the drives and turn off all attached devices and the server. Then, disconnect all power cords from electrical outlets and disconnect all cables that are connected to the server.
2. If the server is installed in a rack cabinet, remove the server from the rack cabinet and place it on a flat, clean, and static-protective surface. See the *Rack Installation Instructions* that comes with the server.
3. Remove the server cover. See “Removing the server cover” on page 69.
4. Remove the cooling shroud. See “Removing and reinstalling the cooling shroud” on page 73.
5. Remove the heat sink. See “Installing or replacing a heat sink” on page 110.

6. Locate the microprocessor socket, press down the small handle on the microprocessor socket, and then pull the handle a little bit outward to release it from the secured position. Then, gently press the microprocessor retainer to open it. Ensure that the small handle and the microprocessor retainer are in the fully open position.

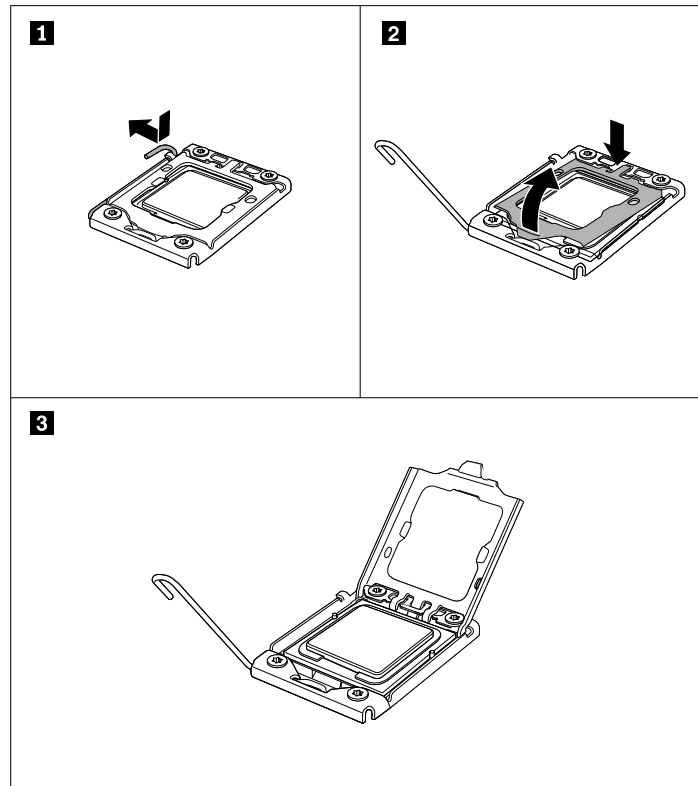

Figure 67. Opening the handle and microprocessor retainer

7. Touch only the edges of the microprocessor and carefully lift it straight up and out of the microprocessor socket. Place the old microprocessor on a static-protective surface.

Notes:

- Do not touch the gold contacts on the bottom of the microprocessor.
- Do not drop anything onto the microprocessor socket while it is exposed. The socket pins must be kept as clean as possible.

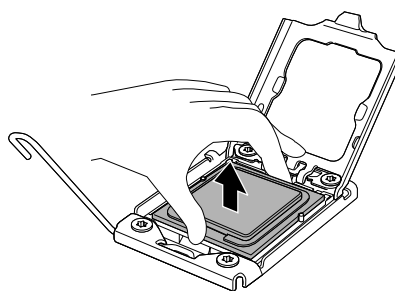

Figure 68. Removing the microprocessor

8. Touch the static-protective package that contains the new microprocessor to any unpainted surface on the outside of the server. Then, remove the new microprocessor from the package.
9. Remove the protective cover that protects the gold contacts on the bottom of the new microprocessor. Do not touch the pins on the microprocessor socket and the gold contacts on the bottom of the new microprocessor.

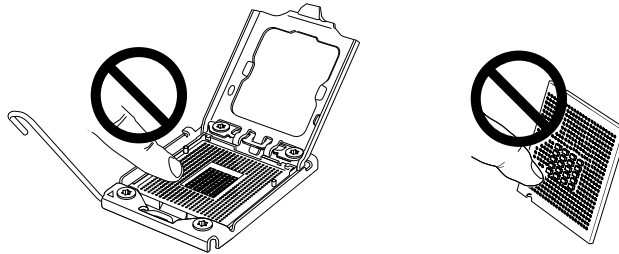

Figure 69. Do not touch the pins

10. Note the orientation of the new microprocessor. Hold the new microprocessor by its edges and align the notches **1** on it with the tabs **2** in the microprocessor socket. Then, carefully lower the new microprocessor straight down into the microprocessor socket.

Note: The small triangle **3** on one corner of the new microprocessor is the microprocessor orientation indicator. The new microprocessor is in the correct orientation when this indicator faces the beveled corner **4** of the microprocessor socket.

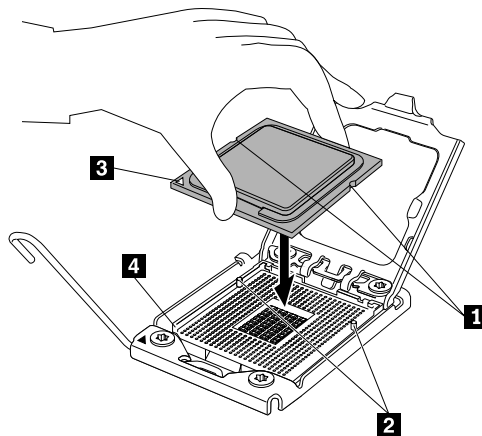

Figure 70. Installing the microprocessor

11. Gently close the microprocessor retainer, press down the small handle, and then push the handle inward to lock the retainer into position and secure the new microprocessor in the socket.

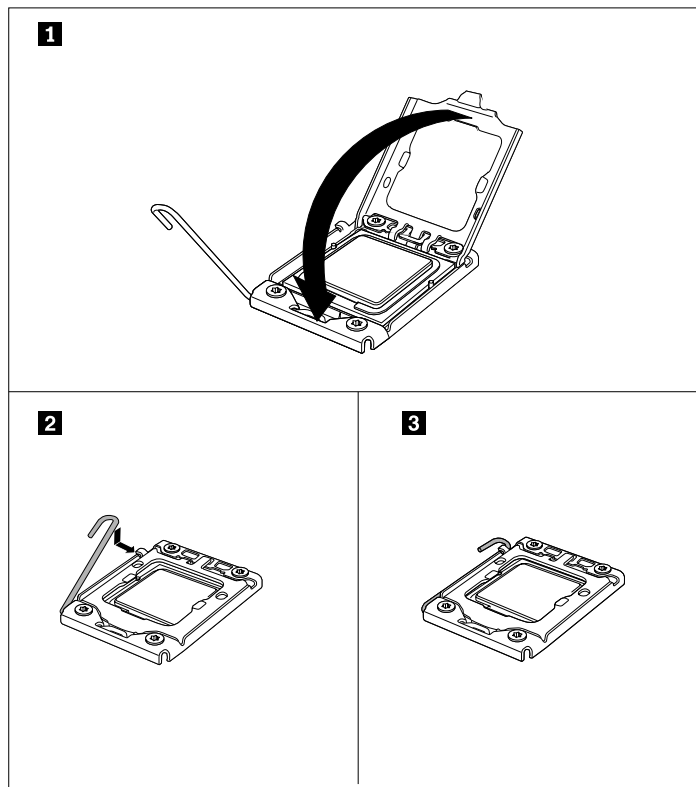

Figure 71. Securing the microprocessor in the socket

12. Reinstall the heat sink. See “Installing or replacing a heat sink” on page 110.
13. If you are instructed to return the old microprocessor, follow all packaging instructions and use any packaging materials that are supplied to you for shipping.

What to do next:

- To work with another piece of hardware, go to the appropriate section.
- To complete the replacement, go to “Completing the parts replacement” on page 147.

Installing or replacing a hot-swap hard disk drive

Attention: Do not open your server or attempt any repair before reading and understanding “Safety information” on page iii and “Guidelines” on page 67.

This topic provides instructions on how to install or replace a hot-swap hard disk drive.

For a list of the ThinkServer hard disk drive options, go to:
<http://www.lenovo.com/thinkserver>

You can install or replace a failing hot-swap hard disk drive without turning off the server, which helps you avoid significant interruption to the operation of the system.

The EMI integrity and cooling of the server are protected by having all drive bays covered or occupied. The number of the installed hard disk drives in your server varies depending on the server model. The vacant bays are occupied by dummy hard disk drive trays. When you install a hot-swap hard disk drive, save the removed dummy hard disk drive tray from the drive bay in the event that you later remove the hot-swap hard disk drive and need the dummy tray to cover the place.

Attention: An unoccupied drive bay without any other protection might impact the EMI integrity and cooling of the server, which might result in overheating or component damage. To maintain the EMI integrity and cooling of the server, install a new hot-swap hard disk drive as soon as you remove the failing one or the dummy tray.

Before you begin, review the following hard disk drive installation rules:

- Follow the order of the hard disk drive bays when installing a hard disk drive. See “Server components” on page 22 to locate the hard disk drive bays in your server.
- For RAID configuration, the hard disk drives must be the same type with the same capacity if they are within a single RAID array. For more information, see “Configuring RAID” on page 56.
- For hard disk drives with different capacities, install the hard disk drive by following the order of the hard disk drive bays as well as the order from the lowest capacity to the highest capacity.

Before you begin, print all the related instructions or ensure that you can view the PDF version on another computer for reference.

Notes:

- Depending on the model, your server might come with 3.5-inch hot-swap hard disk drives or 2.5-inch hot-swap hard disk drives. The illustrations in this topic are based on server models with 3.5-inch hot-swap hard disk drives. For other models, the replacement procedure is similar.
- Depending on the model, your server might look slightly different from the illustrations in this topic.
- Use any documentation that comes with the hot-swap hard disk drive and follow those instructions in addition to the instructions in this topic.

To install or replace a hot-swap hard disk drive, do the following:

1. Locate the appropriate hard disk drive bay. See “Server components” on page 22.

2. Press the release button **1** to open the handle of the hot-swap hard disk drive or the dummy tray.

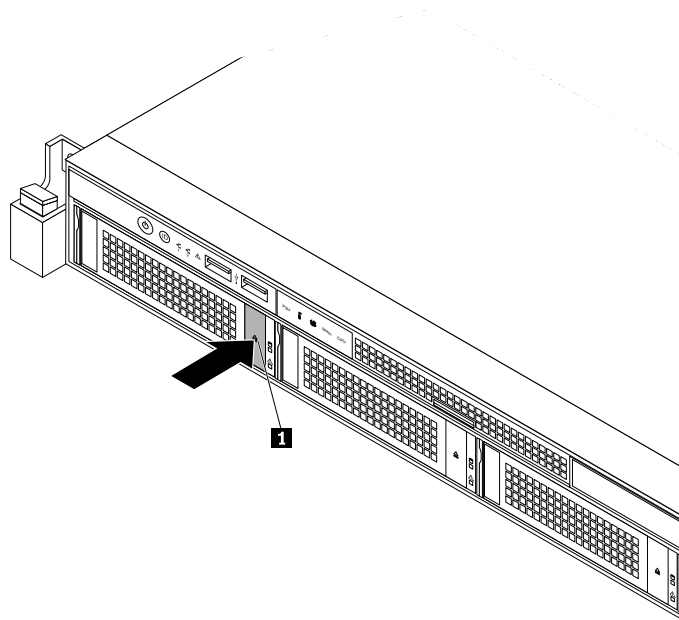

Figure 72. Opening the handle of the hot-swap hard disk drive

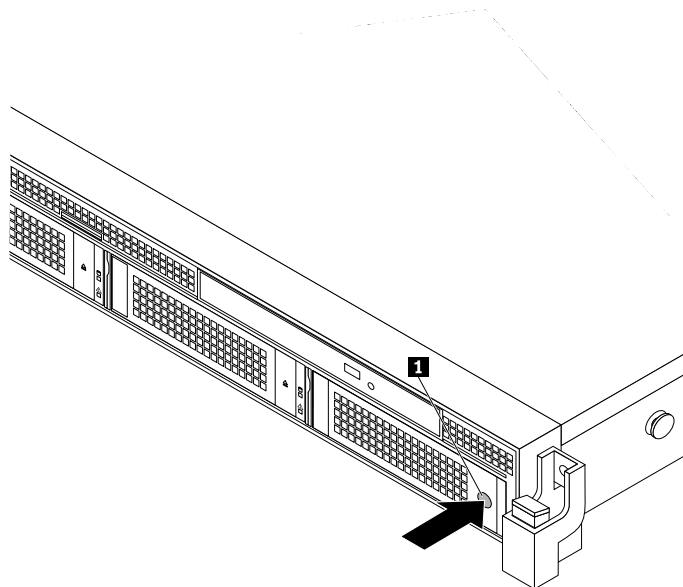

Figure 73. Opening the handle of the dummy hot-swap hard disk drive tray

3. Pull the handle and carefully slide the hot-swap hard disk drive or the dummy tray out of the front of the chassis.

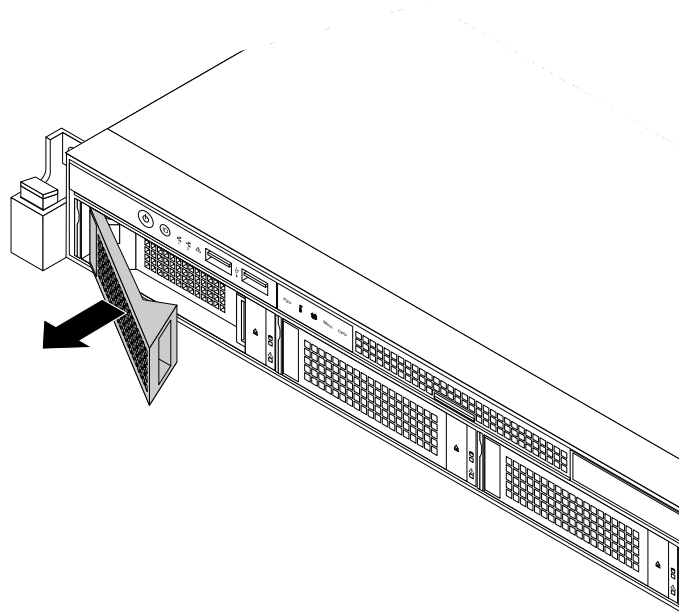

Figure 74. Removing the hot-swap hard disk drive

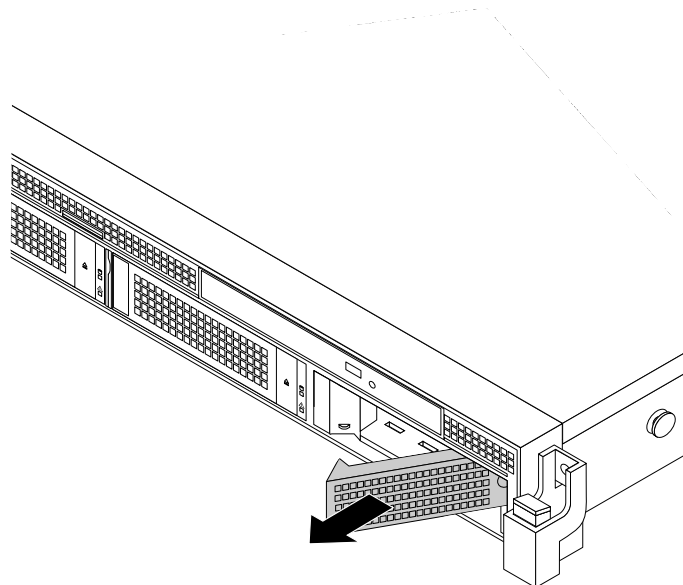

Figure 75. Removing the dummy hot-swap hard disk drive tray

4. Touch the static-protective package that contains the new hot-swap hard disk drive to any unpainted surface on the outside of the server. Then, take the new hot-swap hard disk drive out of the package.

Note: Do not touch the circuit board on the hard disk drive.

- Slide the new hot-swap hard disk drive into the drive bay from the front until it snaps into position and then completely close the handle.

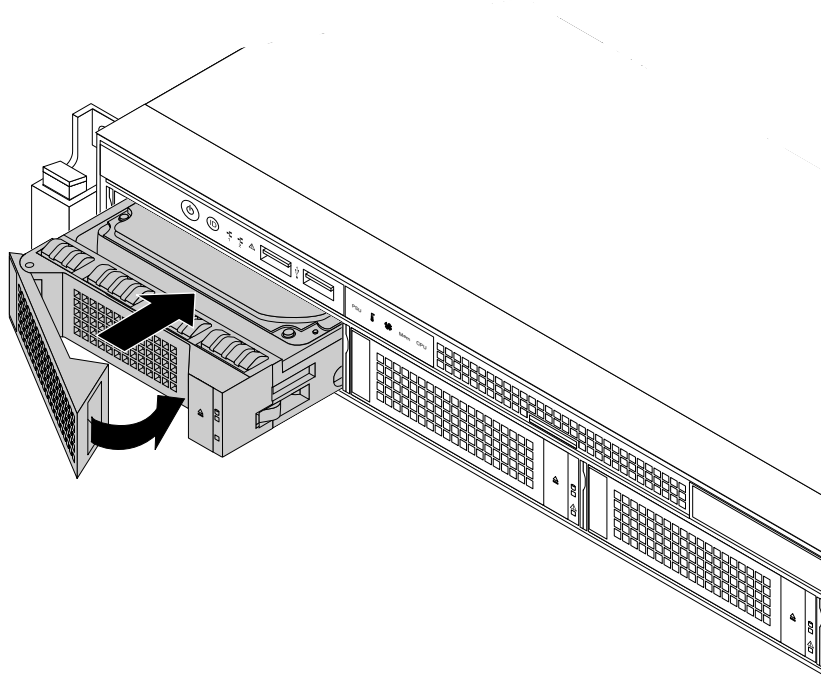

Figure 76. Installing the hot-swap hard disk drive

- Check the hot-swap hard disk drive status LEDs to ensure that the hard disk drive is operating correctly. You might have to restart the server for the newly installed hard disk drive to be recognized. See “Hot-swap hard disk drive status LEDs” on page 25. If the hard disk drive is faulty, you need to reinstall or replace it until it is operating correctly.
- Do one of the following:
 - If you are installing a hot-swap hard disk drive, save the removed dummy hard disk drive tray in the event that you later remove the hot-swap hard disk drive and need a dummy tray to cover the drive bay.
 - If you are replacing a failing hot-swap hard disk drive and are instructed to return the failing hot-swap hard disk drive, follow all packaging instructions and use any packaging materials that are supplied to you for shipping.

What to do next:

- To work with another piece of hardware, go to the appropriate section.
- To configure RAID, go to “Configuring RAID” on page 56.

Installing or replacing the optical drive

Attention: Do not open your server or attempt any repair before reading and understanding “Safety information” on page iii and “Guidelines” on page 67.

This topic provides instructions on how to install or replace the optical drive.

This topic contains the following items:

- Installing or replacing the optical drive for server models with 3.5-inch hard disk drives
- Installing or replacing the optical drive for server models with 2.5-inch hard disk drives

Installing or replacing the optical drive for server models with 3.5-inch hard disk drives

Attention: Do not open your server or attempt any repair before reading and understanding “Safety information” on page iii and “Guidelines” on page 67.

This topic provides instructions on how to install or replace the optical drive for server models with 3.5-inch hard disk drives.

CAUTION:

When laser products (such as CD-ROMs, DVD drives, fiber optic devices, or transmitters) are installed, note the following:

- **Do not remove the covers. Removing the covers of the laser product could result in exposure to hazardous laser radiation. There are no serviceable parts inside the device.**
- **Use of controls or adjustments or performance of procedures other than those specified herein might result in hazardous radiation exposure.**



DANGER

Some laser products contain an embedded Class 3A or Class 3B laser diode. Note the following:

Laser radiation when open. Do not stare into the beam, do not view directly with optical instruments, and avoid direct exposure to the beam.

Before you begin, print all the related instructions or ensure that you can view the PDF version on another computer for reference.

Notes:

- Depending on the model, your server might look slightly different from the illustrations in this topic.
- Use any documentation that comes with the new optical drive and follow those instructions in addition to the instructions in this topic.
- If no optical drive is installed on your server, there is a dummy optical drive.

To install or replace the optical drive for server models with 3.5-inch hard disk drives, do the following:

1. Remove all media from the drives and turn off all attached devices and the server. Then, disconnect all power cords from electrical outlets and disconnect all cables that are connected to the server.
2. If the server is installed in a rack cabinet, remove the server from the rack cabinet and place it on a flat, clean, and static-protective surface. See the *Rack Installation Instructions* that comes with the server.
3. Remove the server cover. See “Removing the server cover” on page 69.
4. Locate the optical drive or dummy optical drive bay. See “Server components” on page 22.
5. Do one of the following:

- If you are replacing an optical drive, disconnect the signal cable and the power cable from the rear of the optical drive. Press the rear of the retaining bracket **1** in the direction as shown and push the optical drive from the rear until it is projected from the front of the chassis. Then, hold the optical drive from the front and completely slide it out of the chassis.

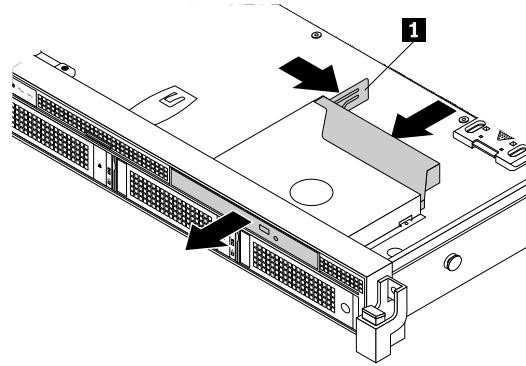

Figure 77. Removing the optical drive for server models with 3.5-inch hard disk drives

- If you are installing an optical drive, remove the dummy optical drive tray. The way of removing the dummy optical drive tray is similar to the way of removing the optical drive that is described above. Store the dummy optical drive tray in the event that you later remove the optical drive and need the dummy optical drive tray to cover the place.
6. Touch the static-protective package that contains the new optical drive to any unpainted surface on the outside of the server. Then, take the new optical drive out of the package.
 7. Remove the retaining bracket from the old optical drive or the dummy optical drive tray. Then, install it on the side of the new optical drive.

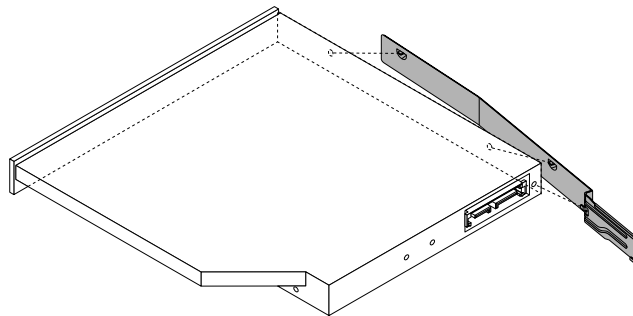

Figure 78. Installing the optical drive retaining bracket

- Slide the new optical drive with the retaining bracket into the drive bay from the front until it snaps into position.

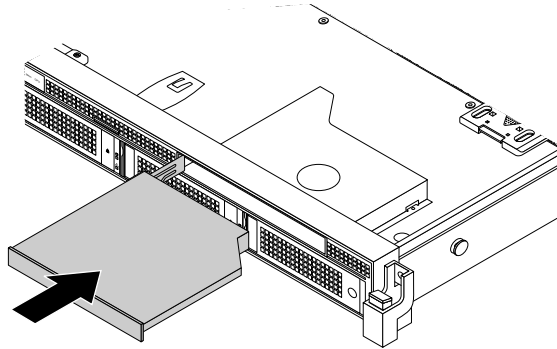

Figure 79. Installing the optical drive for server models with 3.5-inch hard disk drives

- Connect the signal cable **1** and the power cable **2** to the rear of the new optical drive.

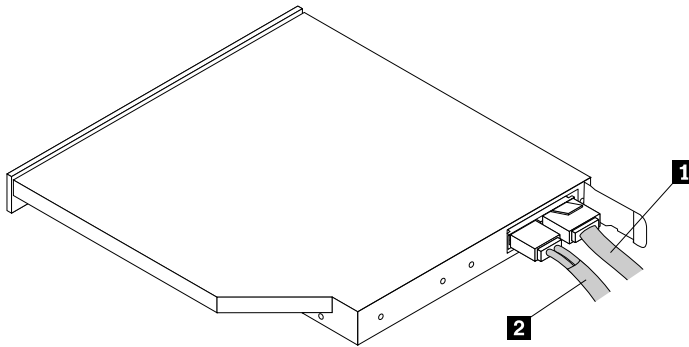

Figure 80. Connecting cables to the rear of the optical drive

- If necessary, connect the other end of the signal cable to the SATA connector 0 on the system board and connect the other end of the power cable to the backplane. See “Reinstalling the server cover and reconnecting cables” on page 147.
- If you are instructed to return the old optical drive, follow all packaging instructions and use any packaging materials that are supplied to you for shipping.

What to do next:

- To work with another piece of hardware, go to the appropriate section.
- To complete the installation or replacement, go to “Completing the parts replacement” on page 147.

Installing or replacing the optical drive for server models with 2.5-inch hard disk drives

Attention: Do not open your server or attempt any repair before reading and understanding “Safety information” on page iii and “Guidelines” on page 67.

This topic provides instructions on how to install or replace the optical drive for server models with 2.5-inch hard disk drives.

CAUTION:

When laser products (such as CD-ROMs, DVD drives, fiber optic devices, or transmitters) are installed, note the following:

- **Do not remove the covers. Removing the covers of the laser product could result in exposure to hazardous laser radiation. There are no serviceable parts inside the device.**
- **Use of controls or adjustments or performance of procedures other than those specified herein might result in hazardous radiation exposure.**



DANGER

Some laser products contain an embedded Class 3A or Class 3B laser diode. Note the following:

Laser radiation when open. Do not stare into the beam, do not view directly with optical instruments, and avoid direct exposure to the beam.

Before you begin, print all the related instructions or ensure that you can view the PDF version on another computer for reference.

Notes:

- Depending on the model, your server might look slightly different from the illustrations in this topic.
- Use any documentation that comes with the new optical drive and follow those instructions in addition to the instructions in this topic.
- If no optical drive is installed on your server, there is a dummy optical drive.

To install or replace the optical drive for server models with 2.5-inch hard disk drives, do the following:

1. Remove all media from the drives and turn off all attached devices and the server. Then, disconnect all power cords from electrical outlets and disconnect all cables that are connected to the server.
2. If the server is installed in a rack cabinet, remove the server from the rack cabinet and place it on a flat, clean, and static-protective surface. See the *Rack Installation Instructions* that comes with the server.
3. Remove the server cover. See “Removing the server cover” on page 69.
4. Locate the optical drive or dummy optical drive bay. See “Server components” on page 22.
5. Do one of the following:

- If you are replacing an optical drive, disconnect the signal cable from the system board and disconnect the power cable from the backplane. Press the rear of the retaining bracket **1** in the direction as shown and push the optical drive from the rear until it is projected from the front of the chassis. Then, hold the optical drive from the front and completely slide it out of the chassis.

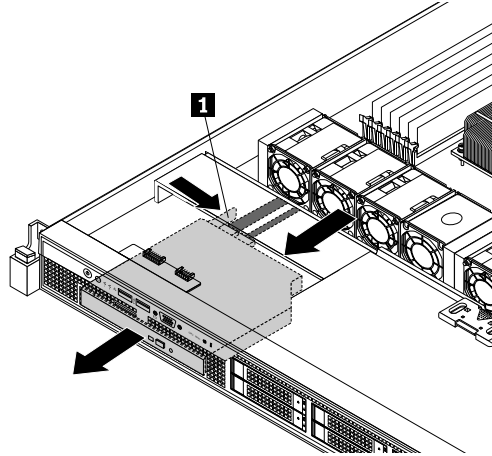

Figure 81. Removing the optical drive for server models with 2.5-inch hard disk drives

- If you are installing an optical drive, remove the dummy optical drive tray. The way of removing the dummy optical drive tray is similar to the way of removing the optical drive that is described above. Store the dummy optical drive tray in the event that you later remove the optical drive and need the dummy optical drive tray to cover the place.
6. Touch the static-protective package that contains the new optical drive to any unpainted surface on the outside of the server. Then, take the new optical drive out of the package.
 7. Remove the retaining bracket from the old optical drive or the dummy optical drive tray. Then, install it on the side of the new optical drive.

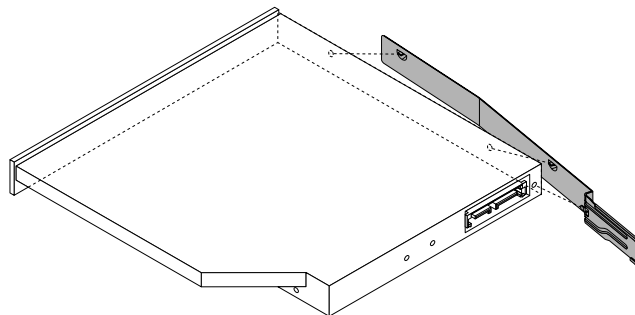

Figure 82. Installing the optical drive retaining bracket

8. Connect the signal cable **1** and the power cable **2** to the rear of the new optical drive.

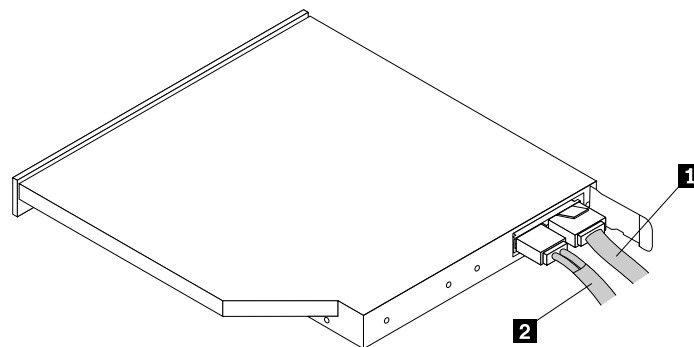

Figure 83. Connecting cables to the rear of the optical drive

9. Slide the new optical drive with the retaining bracket and cables into the drive bay from the front until it snaps into position.

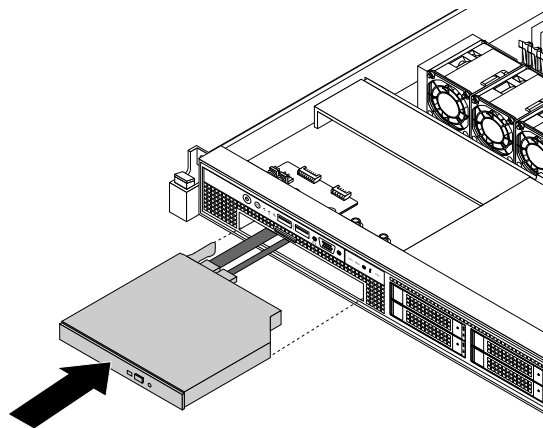

Figure 84. Installing the optical drive for server models with 2.5-inch hard disk drives

10. Connect the other end of the signal cable to the SATA connector 0 on the system board and connect the other end of the power cable to the backplane. See “Reinstalling the server cover and reconnecting cables” on page 147.
11. If you are instructed to return the old optical drive, follow all packaging instructions and use any packaging materials that are supplied to you for shipping.

What to do next:

- To work with another piece of hardware, go to the appropriate section.
- To complete the installation or replacement, go to “Completing the parts replacement” on page 147.

Replacing the hot-swap hard disk drive backplane

Attention: Do not open your server or attempt any repair before reading and understanding “Safety information” on page iii and “Guidelines” on page 67.

This topic provides instructions on how to replace the hot-swap hard disk drive backplane.

Before you begin, print all the related instructions or ensure that you can view the PDF version on another computer for reference.

Notes:

- The hot-swap hard disk drive backplane is sensitive to ESD. Ensure that you read and understand “Handling static-sensitive devices” on page 68 first and carefully perform the operation.
- Depending on the model, your server might look slightly different from the illustrations in this topic.
- The illustrations in the following procedure show the backplane for 3.5-inch hard disk drives. For the backplane for 2.5-inch hard disk drives, the replacement procedure is similar.
- In the following illustrations, system fans are removed in order to make the hot-swap hard disk drive backplane clearly visible.

To replace the hot-swap hard disk drive backplane, do the following:

1. Remove all media from the drives and turn off all attached devices and the server. Then, disconnect all power cords from electrical outlets and disconnect all cables that are connected to the server.
2. If the server is installed in a rack cabinet, remove the server from the rack cabinet and place it on a flat, clean, and static-protective surface. See the *Rack Installation Instructions* that comes with the server.
3. Remove the server cover. See “Removing the server cover” on page 69.
4. Locate the hot-swap hard disk drive backplane. See “Hot-swap hard disk drive backplane” on page 27.
5. Remove all the installed hot-swap hard disk drives and dummy trays (if any) from the hard disk drive bays. See “Installing or replacing a hot-swap hard disk drive” on page 122.
6. Note down the cable connections on the backplane and then disconnect all cables from the backplane.

7. Press the two retaining latches in the direction as shown to release the backplane.

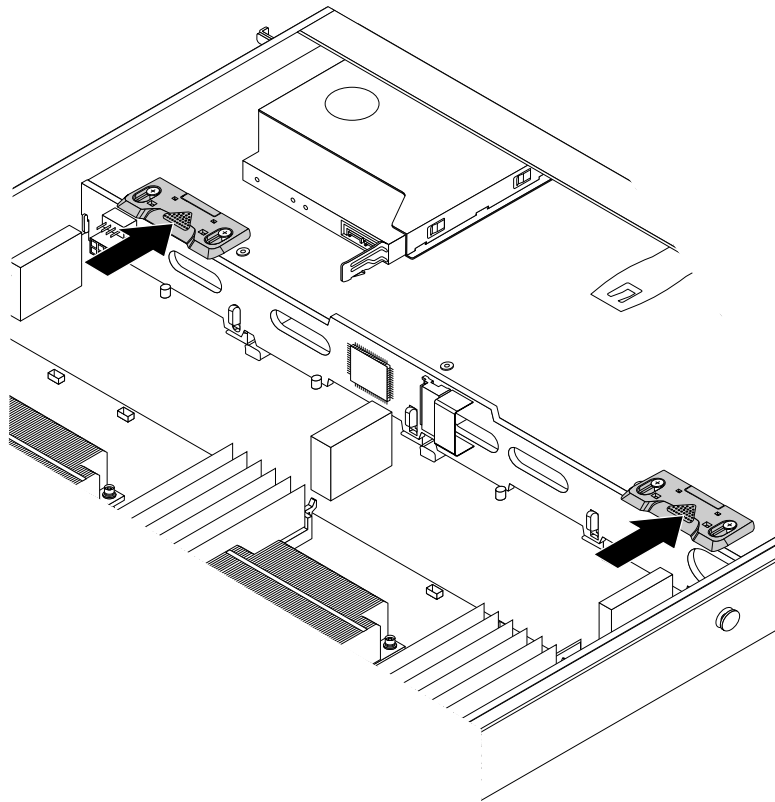

Figure 85. Releasing the backplane

- Carefully lift up the backplane. When the hooks **1** on the chassis are aligned with the corresponding holes in the backplane, slowly move the backplane a little bit outward. Then, completely remove the backplane.

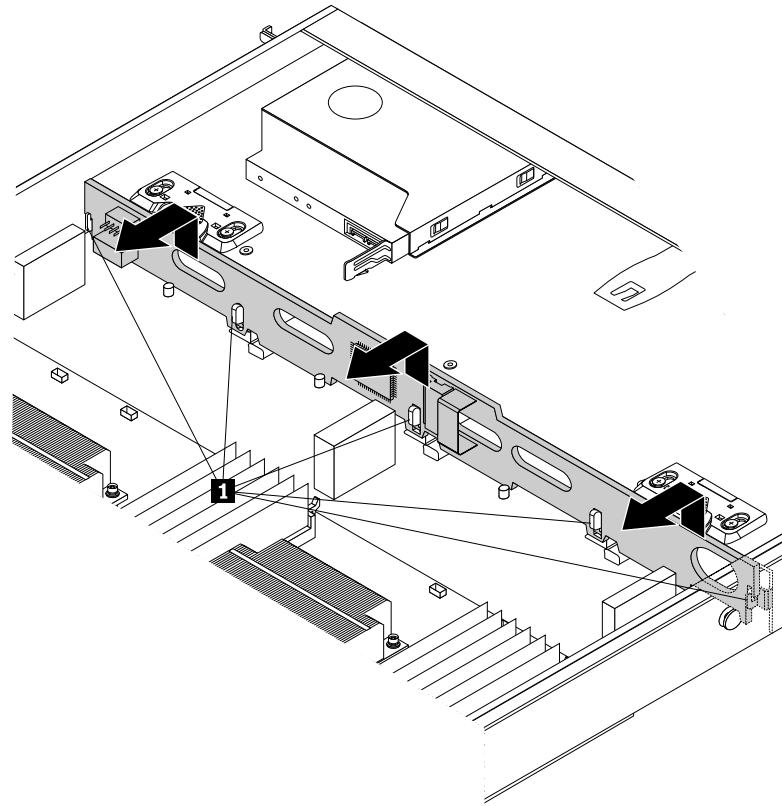

Figure 86. Removing the backplane

- Touch the static-protective package that contains the new hot-swap hard disk drive backplane to any unpainted surface on the outside of the server. Then, remove the new backplane from the package.

Note: Carefully handle the backplane by its edges.

10. Note the orientation of the new backplane and position it on the chassis so that the hooks **1** on the chassis pass through the corresponding holes in the new backplane. Then, carefully press the new backplane straight down until it is secured in place by the small retaining studs on the chassis.

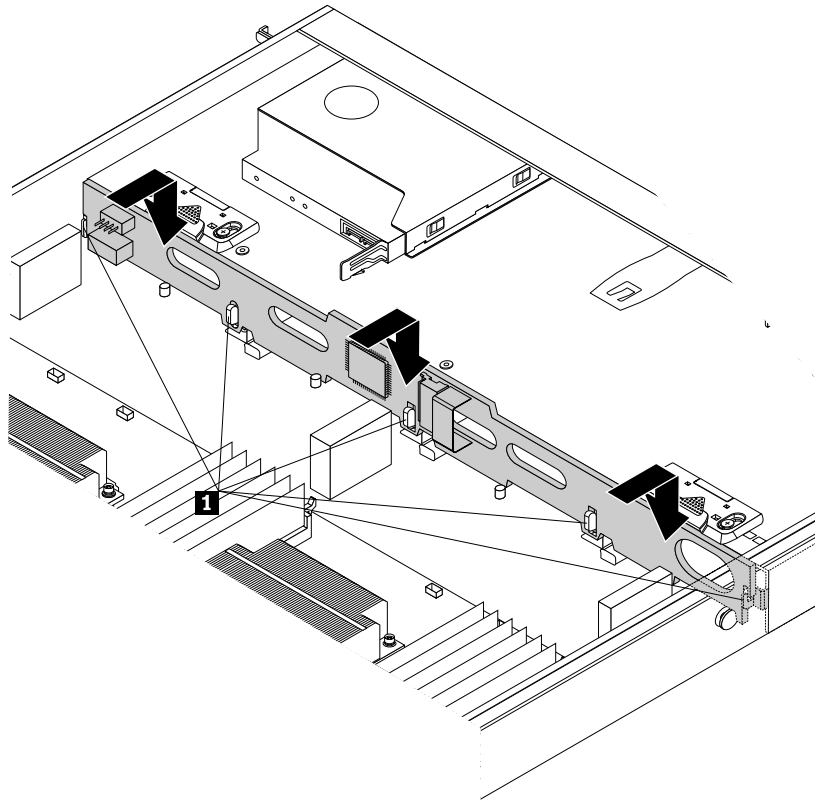

Figure 87. Installing the backplane

11. Press the two retaining latches as shown. Then, the backplane is secured in place.

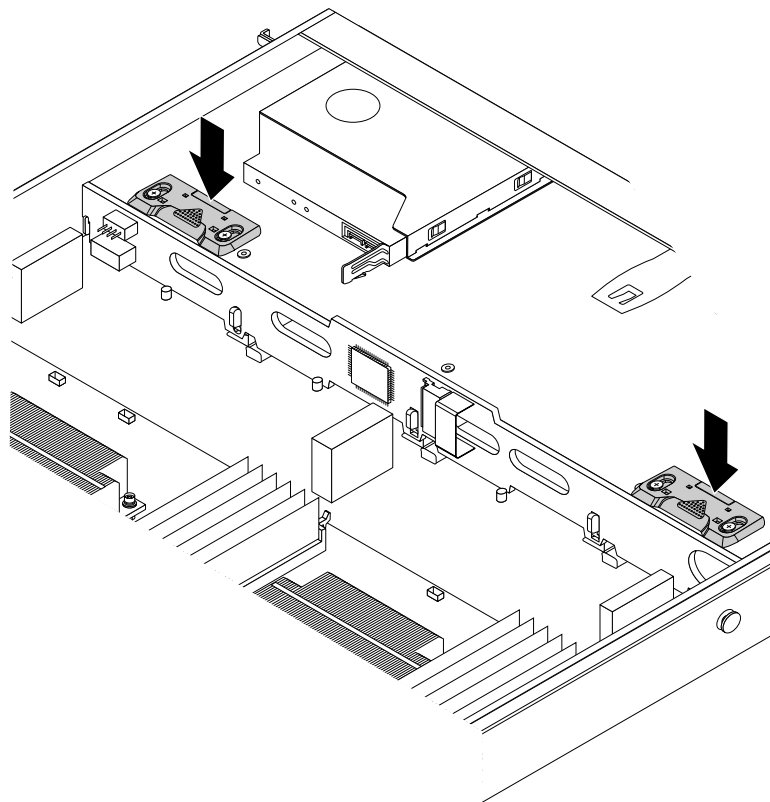

Figure 88. Securing the backplane

12. Reinstall all the hot-swap hard disk drives and dummy trays (if any) in the hard disk drive bays. See “Installing or replacing a hot-swap hard disk drive” on page 122.
13. Refer to your note to connect the cables to the new backplane.
14. If you are instructed to return the old hot-swap hard disk drive backplane, follow all packaging instructions and use any packaging materials that are supplied to you for shipping.

What to do next:

- To work with another piece of hardware, go to the appropriate section.
- To complete the replacement, go to “Completing the parts replacement” on page 147.

Replacing the Intelligent Diagnostics Module

Attention: Do not open your server or attempt any repair before reading and understanding “Safety information” on page iii and “Guidelines” on page 67.

This topic provides instructions on how to replace the Intelligent Diagnostics Module (hereinafter referred to as the IDM).

The IDM provides diagnostic LEDs through the IDM panel to help you easily identify a problem. For more information, see “Intelligent Diagnostics Module” on page 19.

Before you begin, print all the related instructions or ensure that you can view the PDF version on another computer for reference.

Notes:

- Depending on the model, your server might look slightly different from the illustrations in this topic.
- If you remove the IDM, the server will lose the diagnostic LEDs on the IDM panel.

To replace the IDM, do the following:

1. Remove all media from the drives and turn off all attached devices and the server. Then, disconnect all power cords from electrical outlets and disconnect all cables that are connected to the server.
2. If the server is installed in a rack cabinet, remove the server from the rack cabinet and place it on a flat, clean, and static-protective surface. See the *Rack Installation Instructions* that comes with the server.
3. Remove the server cover. See “Removing the server cover” on page 69.
4. Locate the IDM. See “Server components” on page 22.
5. Disconnect the cable from the rear of the IDM.
6. Remove the two screws that secure the IDM and then carefully remove the IDM from the chassis.

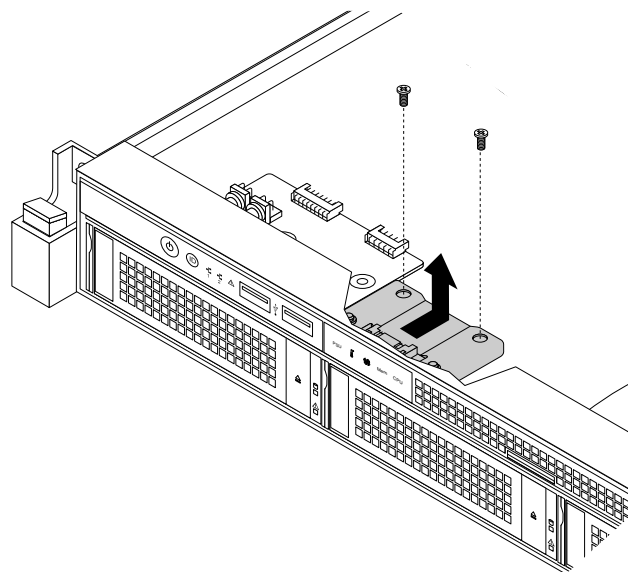

Figure 89. Removing the IDM

7. Touch the static-protective package that contains the new IDM to any unpainted surface on the outside of the server. Then, take the new IDM out of the package.

8. Position the new IDM on the chassis so that the screw holes in the new IDM are aligned with the corresponding mounting studs on the chassis. Then, install the screws to secure the new IDM in place.

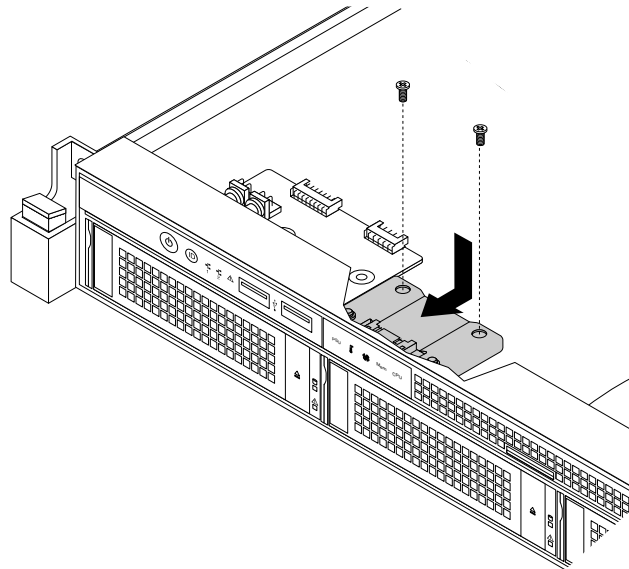

Figure 90. Installing the IDM

9. Connect the IDM cable to the rear of the new IDM.
10. If you are instructed to return the old IDM, follow all packaging instructions and use any packaging materials that are supplied to you for shipping.

What to do next:

- To work with another piece of hardware, go to the appropriate section.
- To complete the replacement, go to “Completing the parts replacement” on page 147.

Replacing a system fan

Attention: Do not open your server or attempt any repair before reading and understanding “Safety information” on page iii and “Guidelines” on page 67.

This topic provides instructions on how to replace a system fan.

CAUTION:

Hazardous moving parts. Keep fingers and other body parts away.

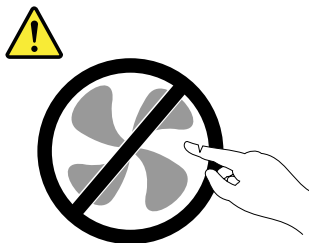

Before you begin, print all the related instructions or ensure that you can view the PDF version on another computer for reference.

Note: Depending on the model, your server might look slightly different from the illustrations in this topic.

To replace a system fan, do the following:

1. Remove all media from the drives and turn off all attached devices and the server. Then, disconnect all power cords from electrical outlets and disconnect all cables that are connected to the server.
2. If the server is installed in a rack cabinet, remove the server from the rack cabinet and place it on a flat, clean, and static-protective surface. See the *Rack Installation Instructions* that comes with the server.
3. Remove the server cover. See “Removing the server cover” on page 69.
4. Remove the cooling shroud. See “Removing and reinstalling the cooling shroud” on page 73.
5. Reconnect the power cord to the server and the electrical outlet.
6. Locate the failing system fan. The system fan error LED on the system board is lit. See “System board LEDs” on page 39.
7. Disconnect the power cord from the electrical outlet.
8. Disconnect the cable of the system fan from the system fan connector on the system board. See “System board components” on page 31 to identify the system fan connector.
9. Lift up the tape of the system fan to remove the system fan out of the chassis.

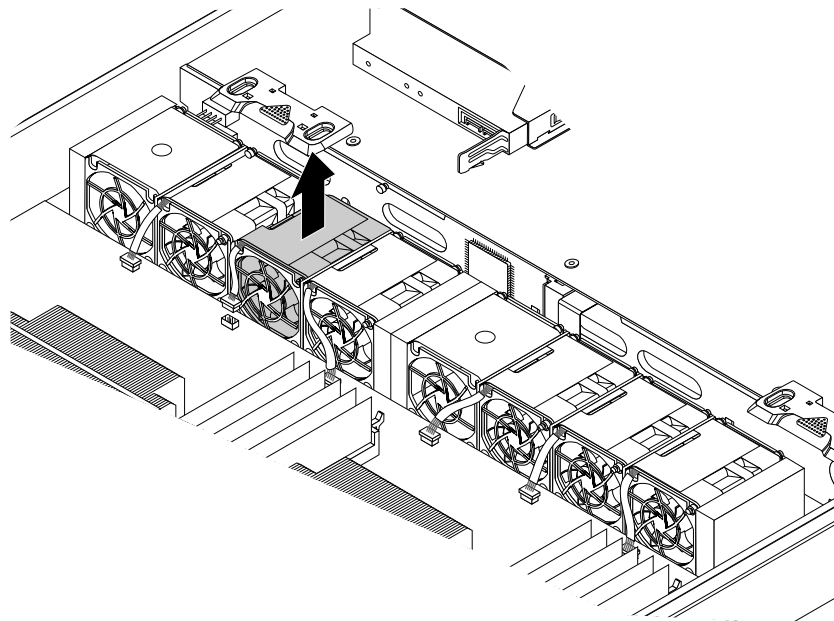

Figure 91. Removing the system fan

10. Touch the static-protective package that contains the new system fan to any unpainted surface on the outside of the server. Then, remove the new system fan from the package.

11. Note the orientation of the new system fan and then insert the new system fan into the chassis until it snaps into position.

Note: Install a new system fan as soon as you remove the failing one.

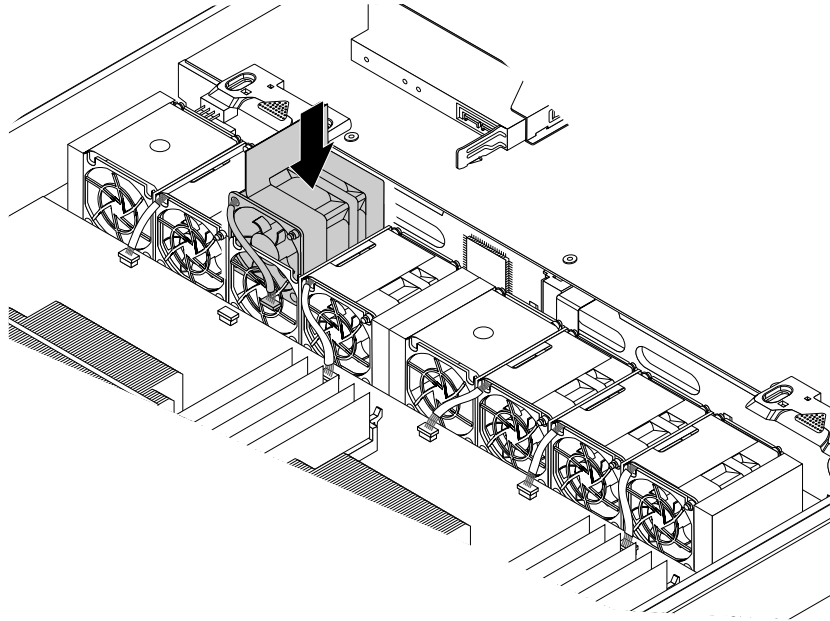

Figure 92. Installing the system fan

12. Press down the tape of the new system fan and then connect the cable of the new system fan to the system fan connector on the system board.
13. If you are instructed to return the old system fan, follow all packaging instructions and use any packaging materials that are supplied to you for shipping.

What to do next:

- To work with another piece of hardware, go to the appropriate section.
- To complete the replacement, go to “Completing the parts replacement” on page 147.

Replacing the front panel board

Attention: Do not open your server or attempt any repair before reading and understanding “Safety information” on page iii and “Guidelines” on page 67.

This topic provides instructions on how to replace the front panel board.

Before you begin, print all the related instructions or ensure that you can view the PDF version on another computer for reference.

Notes:

- Depending on the model, your server might look slightly different from the illustrations in this topic.
- The front panel board is extremely sensitive to ESD. Ensure that you read and understand “Handling static-sensitive devices” on page 68 first and carefully perform the operation.

To replace the front panel board, do the following:

1. Remove all media from the drives and turn off all attached devices and the server. Then, disconnect all power cords from electrical outlets and disconnect all cables that are connected to the server.
2. If the server is installed in a rack cabinet, remove the server from the rack cabinet and place it on a flat, clean, and static-protective surface. See the *Rack Installation Instructions* that comes with the server.
3. Remove the server cover. See “Removing the server cover” on page 69.
4. Locate the front panel board. See “Front view of the server” on page 14.
5. Disconnect the front panel cable and the front panel USB cable from the rear of the front panel board.
6. Remove the two screws that secure the front panel board and then carefully remove the front panel board from the chassis.

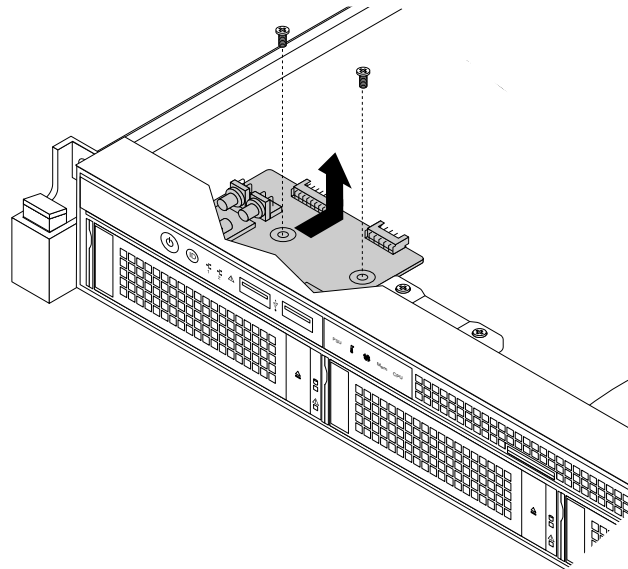

Figure 93. Removing the front panel board

7. Touch the static-protective package that contains the new front panel board to any unpainted surface on the outside of the server. Then, take the new front panel board out of the package.

Note: Carefully handle the front panel board by its edges.

- Carefully position the new front panel board on the chassis so that the front controls, connectors, and LEDs are through the corresponding holes in the front bezel and the two screw holes in the new front panel board are aligned with the corresponding mounting studs on the chassis. Then, install the screws to secure the front panel board in place.

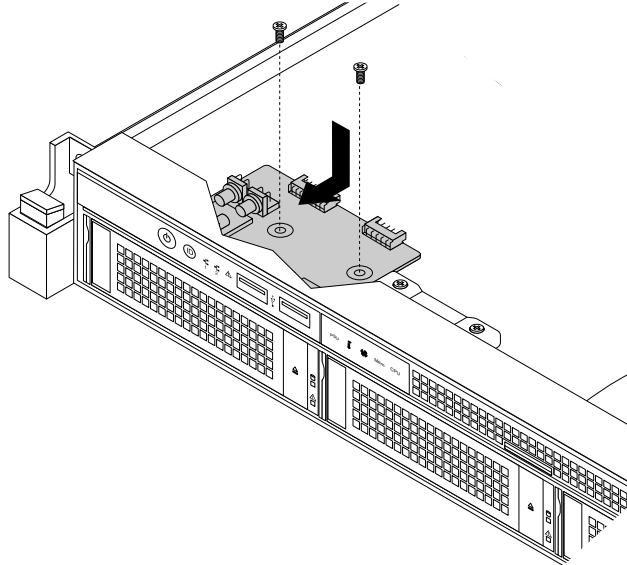

Figure 94. Installing the front panel board

- Connect the front panel cable and the front panel USB cable to the rear of the new front panel board.
- If you are instructed to return the old front panel board, follow all packaging instructions and use any packaging materials that are supplied to you for shipping.

What to do next:

- To work with another piece of hardware, go to the appropriate section.
- To complete the replacement, go to “Completing the parts replacement” on page 147.

Replacing the riser card assembly 1

Attention: Do not open your server or attempt any repair before reading and understanding “Safety information” on page iii and “Guidelines” on page 67.

This topic provides instructions on how to replace the riser card assembly 1.

Before you begin, print all the related instructions or ensure that you can view the PDF version on another computer for reference.

Notes:

- Depending on the model, your server might look slightly different from the illustrations in this topic.
- Use any documentation that comes with the new riser card assembly 1 and follow those instructions in addition to the instructions in this topic.

To replace the riser card assembly 1, do the following:

1. Remove all media from the drives and turn off all attached devices and the server. Then, disconnect all power cords from electrical outlets and disconnect all cables that are connected to the server.
2. If the server is installed in a rack cabinet, remove the server from the rack cabinet and place it on a flat, clean, and static-protective surface. See the *Rack Installation Instructions* that comes with the server.
3. Remove the server cover. See “Removing the server cover” on page 69.
4. Remove the cooling shroud. See “Removing and reinstalling the cooling shroud” on page 73.
5. Locate the riser card assembly 1. See “Server components” on page 22.
6. Grasp the riser card assembly 1 by its edges and carefully lift it straight up and off the chassis.

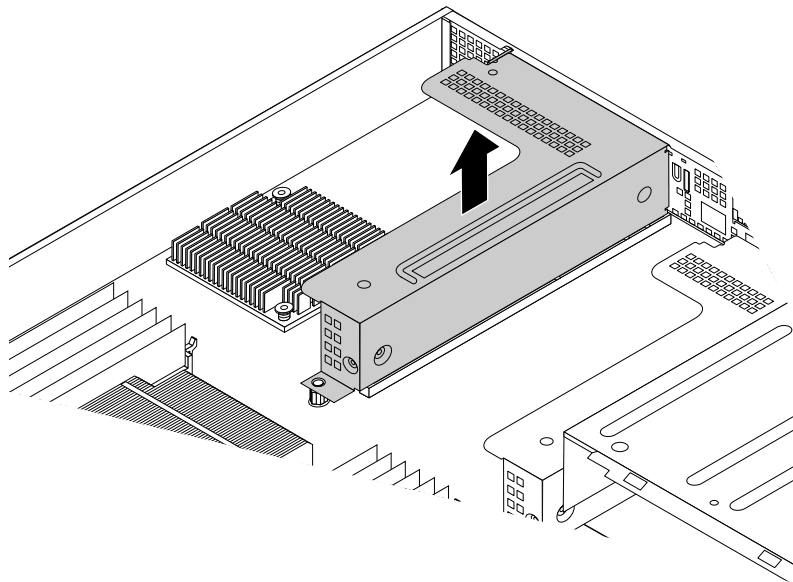

Figure 95. Lifting the riser card assembly 1 off the chassis

7. If there is any PCI Express card (such as an Ethernet card) installed on the riser card assembly 1, note down the cable connections, disconnect all cables from the card, and then completely remove the riser card assembly 1 out of the chassis. Then, remove the PCI Express card from the riser card assembly 1. See “Removing the Ethernet card” on page 83.
8. Touch the static-protective package that contains the new riser card assembly 1 to any unpainted surface on the outside of the server. Then, take the new riser card assembly 1 out of the package.

9. Position the new riser card assembly 1 on the chassis and align it with the riser card assembly 1 slot on the system board and align the rear of it with the corresponding rail guides in the rear of the chassis. Then, press the new riser card assembly 1 straight down until it is securely seated in the slot.

Note: If there is any PCI Express card (such as an Ethernet card) installed on the riser card assembly 1, install the PCI Express card to the new riser card assembly 1 first. See “Installing the Ethernet card” on page 81. Then, refer to your note to reconnect any cables to the PCI Express card on the new riser card assembly 1 and properly route all the cables.

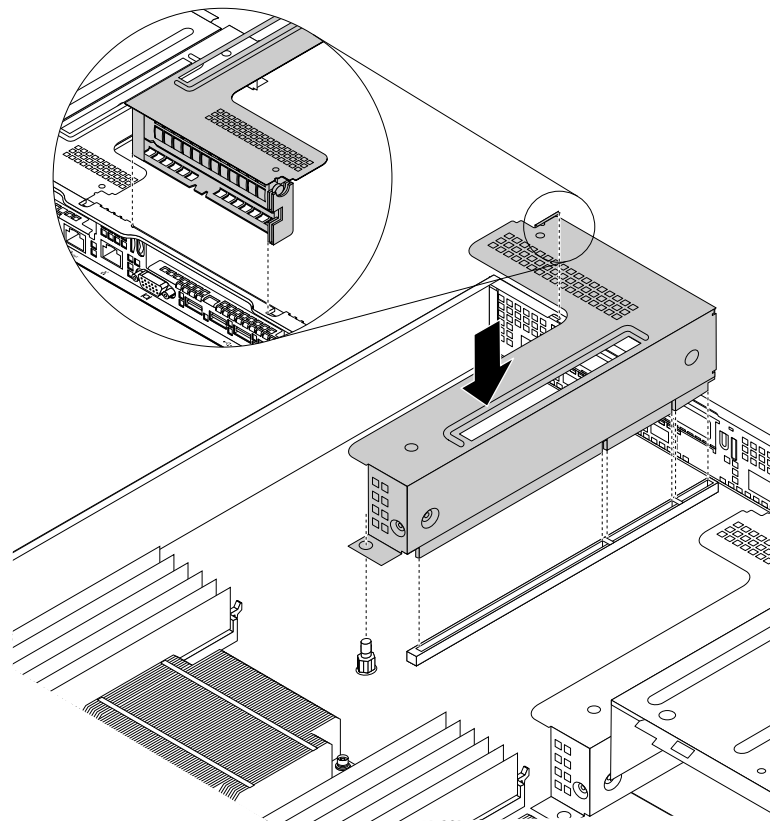

Figure 96. Installing the riser card assembly 1

10. If you are instructed to return the old riser card assembly, follow all packaging instructions and use any packaging materials that are supplied to you for shipping.

What to do next:

- To work with another piece of hardware, go to the appropriate section.
- To complete the replacement, go to “Completing the parts replacement” on page 147.

Replacing the system board battery

Attention: Do not open your server or attempt any repair before reading and understanding “Safety information” on page iii and “Guidelines” on page 67.

This topic provides instructions on how to replace the system board battery.

Your server has a special type of memory that maintains the date, time, and configuration information for built-in features. The system board battery keeps the information active when you turn off the server. The system board battery normally requires no charging or maintenance throughout its life; however, no battery lasts forever. If the system board battery fails, the date, time, and configuration information, including passwords, are lost and an error message is displayed when you turn on the server.



Danger of explosion if battery is incorrectly replaced.

When replacing the lithium coin cell battery, use only the same or an equivalent type that is recommended by the manufacturer. The battery contains lithium and can explode if not properly used, handled, or disposed of.

Do not:

- **Throw or immerse into water**
- **Heat to more than 100°C (212°F)**
- **Repair or disassemble**

Dispose of the battery as required by local ordinances or regulations.

The following statement applies to users in the state of California, U.S.A.

California Perchlorate Information:

Products containing CR (manganese dioxide) lithium coin cell batteries may contain perchlorate.

Perchlorate Material - special handling may apply, See <http://www.dtsc.ca.gov/hazardouswaste/perchlorate>

Before you begin, print all the related instructions or ensure that you can view the PDF version on another computer for reference.

To replace the system board battery, do the following:

Note: After you replace the system board battery, you must reset passwords, reset system date and time, and reconfigure the server.

1. Remove all media from the drives and turn off all attached devices and the server. Then, disconnect all power cords from electrical outlets and disconnect all cables that are connected to the server.
2. If the server is installed in a rack cabinet, remove the server from the rack cabinet and place it on a flat, clean, and static-protective surface. See the *Rack Installation Instructions* that comes with the server.
3. Remove the server cover. See “Removing the server cover” on page 69.
4. Locate the system board battery. See “System board components” on page 31.

Note: If there is any PCI Express card installed on the riser card assembly 1, it might block your access to the system board battery. In this case, you need to remove the cooling shroud and then carefully lift the riser card assembly 1 up so that you can access the system board battery. You do not need to disconnect any cables from the riser card assembly 1 or completely remove the riser card assembly 1.

5. Remove the old system board battery.

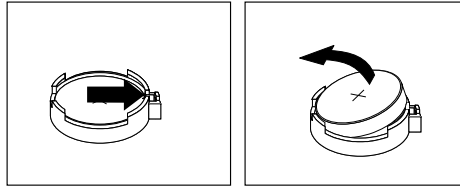

Figure 97. Removing the system board battery

6. Install a new system board battery.

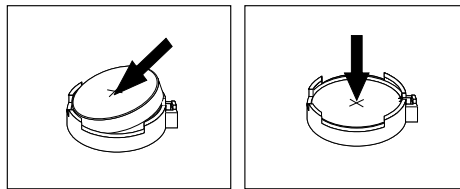

Figure 98. Installing the system board battery

7. If you have lifted up the riser card assembly 1, reinstall it into the chassis. See “Replacing the riser card assembly 1” on page 143.
8. Dispose of the old system board battery as required by local ordinances or regulations.

What to do next:

- To work with another piece of hardware, go to the appropriate section.
- To complete the replacement, go to “Completing the parts replacement” on page 147. After you replace the system board battery, you must reset passwords, reset system date and time, and reconfigure the server. See Chapter 5 “Configuring the server” on page 45.

Completing the parts replacement

This topic provides instructions to help you complete the parts replacement and turn on your server.

To complete the parts replacement, you must properly route the cables inside the server, reinstall the cooling shroud (if necessary), reinstall the server cover, reconnect all the external cables and, for some devices, update the firmware and run the Setup Utility program to do further setup.

Reinstalling the server cover and reconnecting cables

<p>Attention: Do not open your server or attempt any repair before reading and understanding “Safety information” on page iii and “Guidelines” on page 67.</p>

This topic provides instructions on how to reinstall the server cover and reconnect cables to your server.

Attention: For proper cooling and airflow, reinstall the server cover before turning on the server. Operating the server for extended periods of time (more than 30 minutes) with the server cover removed might damage server components.

Before you begin, print all the related instructions or ensure that you can view the PDF version on another computer for reference.

Note: Depending on the model, your server might look slightly different from the illustrations in this topic.

To reinstall the server cover and reconnect cables to your server, do the following:

1. Ensure that all components have been reassembled correctly and that no tools or loose screws are left inside your server.
2. Ensure that all internal cables are routed correctly and secured by any cable clips or ties in the server. Keep cables clear of the hinges and sides of the server chassis to avoid interference with reinstalling the cooling shroud and the server cover. The following illustrations show the cable routing for the two chassis configurations based on the supported hard disk drives.
 - Route the signal cables **1** through the left inner side of the chassis. The signal cables include the mini-SAS to mini-SAS signal cable, the front panel cable, the front panel USB cable, the diagnostic module cable, and the SATA signal cable for the optical drive.
 - Connect the power cable **2** for the optical drive to the optical drive power connector on the backplane and properly route the cable in the chassis.
 - Route the backplane power cable **3** through the right inner side of the chassis.

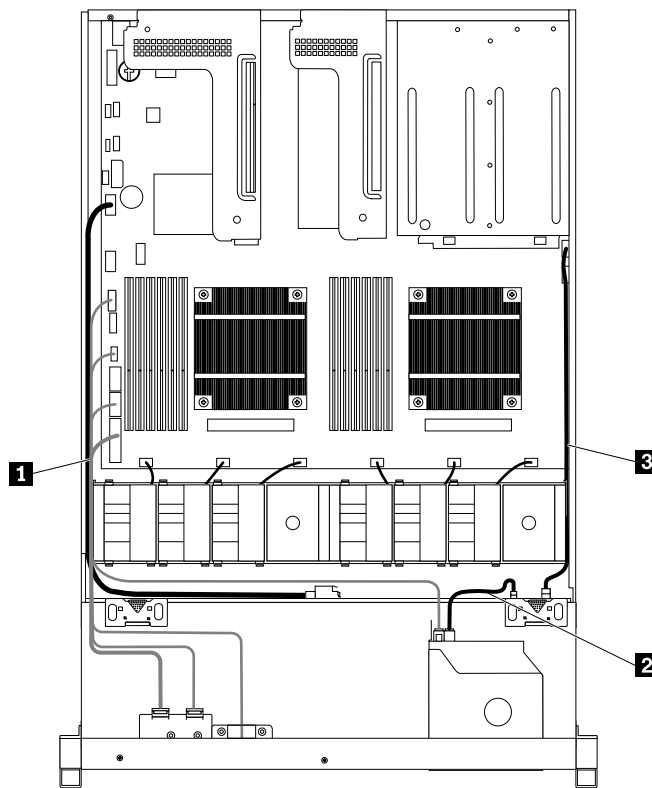

Figure 99. Cable routing for server models with 3.5-inch hard disk drives

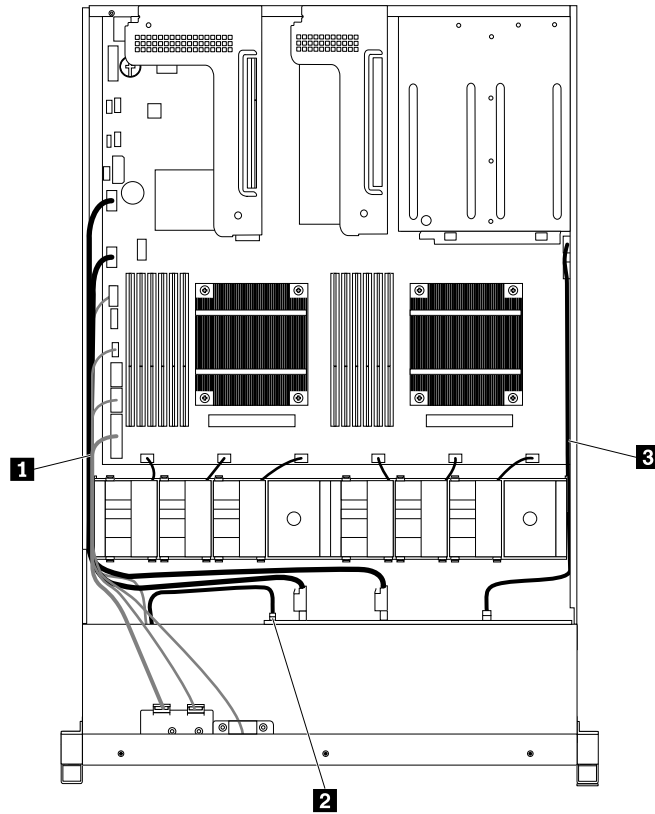

Figure 100. Cable routing for server models with 2.5-inch hard disk drives

3. If the cooling shroud is removed, reinstall the cooling shroud. See “Removing and reinstalling the cooling shroud” on page 73.

4. Ensure that the cover latch is in the open position. Place the server cover above the chassis so that the cover latch is aligned with the cover latch slot in the chassis. Then, lower the server cover onto the chassis until the cover latch is inserted into its slot and both sides of the server cover engage the guides on both sides of the chassis.

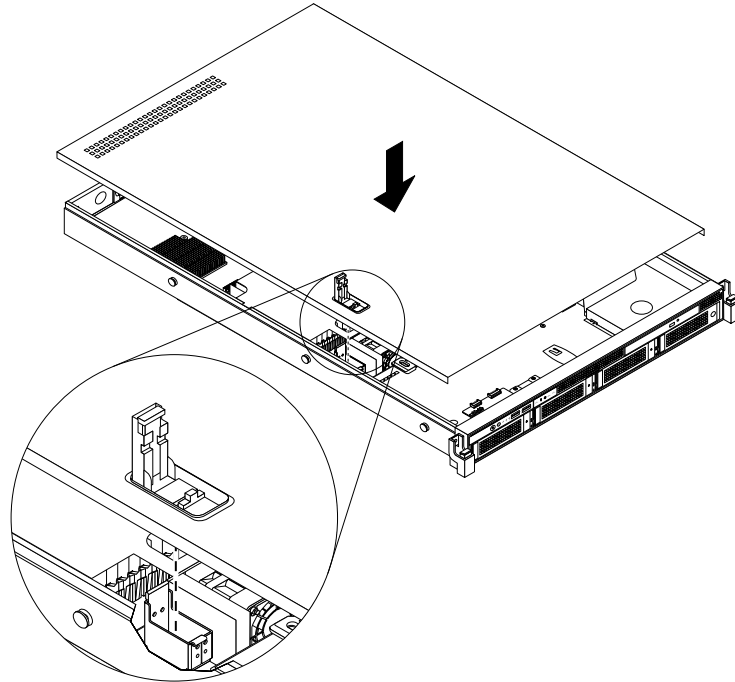

Figure 101. Installing the server cover

5. Pivot the cover latch to the closed position and slide the server cover to the front of the chassis at the same time until the server cover snaps into position and the cover latch is completely closed.

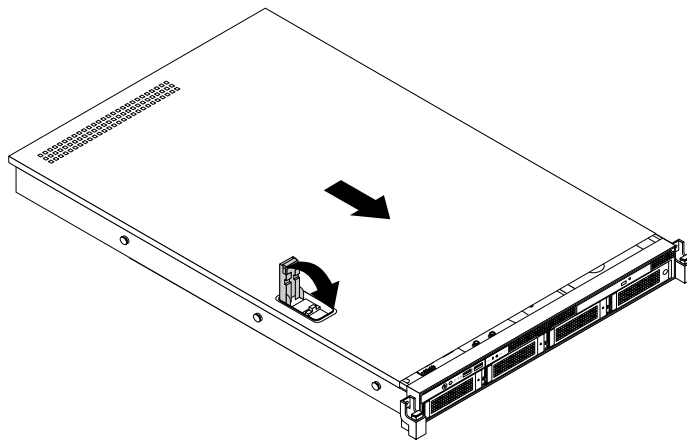

Figure 102. Closing the server cover completely

6. If the server is installed in a rack cabinet, reinstall the server into the rack cabinet. See the *Rack Installation Instructions* that comes with the server.

7. Reconnect external cables and power cord(s) to the server. See “Rear view of the server” on page 20 to identify the connectors on the rear panel of the server.

Attention: To avoid component damage, connect the power cord(s) last.

Note: In most areas of the world, Lenovo requires the return of the defective CRU. Information about this will come with the CRU or will come a few days after the CRU arrives.

Updating the server configuration

When you turn on the server for the first time after you install, remove, or replace a device, you might need to update the server configuration.

Some optional devices have device drivers that you must install. For information about installing device drivers, use the documentation that comes with each optional device. To obtain the supported device drivers for your server from the Lenovo Support Web site, go to <http://www.lenovo.com/drivers>, and then follow the instructions on the Web page to find and download the device drivers you need.

Refer to the following information resources to update the server configuration:

- To update the BIOS configuration, see “Using the Setup Utility program” on page 45.
- To update the RAID configuration, see “Configuring RAID” on page 56.
- To use the ThinkServer EasyStartup program, see “Using the ThinkServer EasyStartup program” on page 53.
- To update your system firmware, see “Updating the firmware” on page 64.

Chapter 7. Troubleshooting and diagnostics

This chapter provides information about basic troubleshooting and diagnostic methods to help you solve problems that might occur in the server.

If you cannot diagnose and correct a problem by using the information in this chapter, see Chapter 8 “Getting information, help, and service” on page 159 for additional troubleshooting resources.

Troubleshooting procedure

Use the following information as a general procedure for diagnosing and troubleshooting problems you experience with your server:

1. Verify that the power cords and the cables for all attached devices are connected correctly and securely.
2. Verify that the server and all attached devices that require ac power are connected to properly grounded, functioning electrical outlets.
3. Verify that all installed hardware and attached devices are enabled in the BIOS settings of your server. For more information about accessing and changing the BIOS settings, see “Using the Setup Utility program” on page 45.
4. View the status and diagnostic LEDs to identify the system and device status and diagnose problems. See “Viewing the status and diagnostic LEDs” on page 153.
5. If the server is not working after you have added new software, installed a new optional device, or replaced a piece of hardware, remove or reinstall the software, device, or hardware to see if the problem could be solved.
6. View the system event log to diagnose problems. See “Viewing the system event log” on page 153.
7. Turn on the server and press Esc as soon as you see the logo screen to view any diagnostic messages.
8. Refer to “Basic troubleshooting tables” on page 154 and follow the instructions for the type of problem you are experiencing. If the basic troubleshooting information does not help you resolve a problem, continue with the next step.
9. Try using a previous server configuration to see if a recent change to hardware or software settings has caused a problem. Before restoring your previous configuration, capture your current configuration in case the older configuration settings do not solve the problem or have adverse effect.
10. Use an antivirus program to see if your server has been infected by a virus. If the program detects a virus, remove the virus.
11. If none of these actions solve the problem, seek technical assistance. See Chapter 8 “Getting information, help, and service” on page 159.

Viewing the status and diagnostic LEDs

Your server has status and diagnostic LEDs on the front panel, the rear panel, the panel of the diagnostic module (varies by model), the system board, the hot-swap hard disk drives, and the optical drive (if supported). The various LEDs help you easily identify the system and device status and diagnose problems. For information about the LEDs, refer to the related topics in “Locations” on page 13.

Viewing the system event log

The system event log (SEL) contains information about all the POST and system management interrupt (SMI) events. You can view the SEL to diagnose system problems.

The TMM implements the SEL as specified in the IPMI 2.0 specification. The SEL is accessible regardless of the system power state through the TMM in-band and out-of-band interfaces.

For more information about viewing the SEL, refer to the *ThinkServer Management Module User Guide*, which is available for download at <http://www.lenovo.com/ThinkServerUserGuides>.

Basic troubleshooting tables

Use the basic troubleshooting information to find solutions to problems that have definite symptoms.

ThinkServer EasyStartup program problems

Follow the suggested actions for the corresponding symptom in the order in which they are listed until the problem is solved. If none of these actions solve the problem, see “Troubleshooting procedure” on page 153 for the subsequent steps you should check after using the information in this topic. If the problem still cannot be solved, seek technical assistance. See Chapter 8 “Getting information, help, and service” on page 159.

Note: If you are instructed to remove, install, or replace any CRUs, refer to the related procedure in Chapter 6 “Installing, removing, or replacing hardware” on page 67.

Symptom	Action
The <i>ThinkServer EasyStartup</i> DVD does not start.	<ol style="list-style-type: none">1. Ensure that the server supports the ThinkServer EasyStartup program and has a bootable DVD drive installed or a bootable external DVD drive attached.2. Ensure that you have set the optical drive with the <i>ThinkServer EasyStartup</i> DVD installed as the first startup device. See “Selecting a startup device” on page 50.3. Verify if the optical drive or the disc has problems. See “Optical drive problems” on page 154.
The operating system installation program continuously loops.	Make more space available on the hard disk drive.
The ThinkServer EasyStartup program cannot start the operating system medium.	<ol style="list-style-type: none">1. Ensure that the operating system medium is supported by the ThinkServer EasyStartup program version you are using. For a list of the supported operating systems, refer to the user guide and compatibility notes for the ThinkServer EasyStartup program through the program main interface. See “Starting the ThinkServer EasyStartup program” on page 54.2. Verify if the optical drive or the disc has problems. See “Optical drive problems” on page 154.

Optical drive problems

Follow the suggested actions for the corresponding symptom in the order in which they are listed until the problem is solved. If none of these actions solve the problem, see “Troubleshooting procedure” on page 153 for the subsequent steps you should check after using the information in this topic. If the problem still cannot be solved, seek technical assistance. See Chapter 8 “Getting information, help, and service” on page 159.

Notes:

- If you are instructed to remove, install, or replace any CRUs, refer to the related procedure in Chapter 6 “Installing, removing, or replacing hardware” on page 67.

- If an action step is preceded by “(Trained service technician only),” this action step is reserved for a trained service technician and must be performed only by a trained service technician.

Symptom	Action
The optical drive is not recognized.	<ol style="list-style-type: none"> 1. Ensure that: <ul style="list-style-type: none"> • The related cables and connectors are not damaged and the connector pins are not bent. • The optical drive is securely connected to the correct SATA connector on the system board and the SATA connector is enabled in the Setup Utility program. See “Using the Setup Utility program” on page 45. • All cables and jumpers (if any) are installed correctly. • The correct device driver is installed for the optical drive. 2. Run any optical drive diagnostic programs if you have. 3. Reinstall the optical drive and reconnect cables. 4. Replace the signal cable for the optical drive. 5. Replace the power cable for the optical drive. 6. Replace the power cable for the backplane. 7. Replace the optical drive. 8. Replace the backplane. 9. (Trained service technician only) Replace the system board.
A disc is not working correctly.	<ol style="list-style-type: none"> 1. Ensure that the disc is in the optical drive with the shiny side facing down. 2. Ensure that the disc surface is clean and not scratched. 3. Check the disc or package for regional coding. You might need to purchase a disc with coding for the region where you are using the product. 4. Restart the disc player program. 5. Restart the server. 6. Run any optical drive diagnostic programs if you have. 7. Reinstall the optical drive and reconnect cables. 8. Replace the signal cable for the optical drive. 9. Replace the optical drive.

Hard disk drive problems

Follow the suggested actions for the corresponding symptom in the order in which they are listed until the problem is solved. If none of these actions solve the problem, see “Troubleshooting procedure” on page 153 for the subsequent steps you should check after using the information in this topic. If the problem still cannot be solved, seek technical assistance. See Chapter 8 “Getting information, help, and service” on page 159.

Notes:

- If you are instructed to remove, install, or replace any CRUs, refer to the related procedure in Chapter 6 “Installing, removing, or replacing hardware” on page 67.
- The status LEDs on each hot-swap hard disk drive help you easily identify a problem. See “Hot-swap hard disk drive status LEDs” on page 25.

Symptom	Action
A newly installed hot-swap hard disk drive is not recognized.	<ol style="list-style-type: none"> 1. Ensure that the drive is installed into the correct drive bay. 2. Restart the server. 3. Remove the drive from the bay, wait 45 seconds, and reinsert the drive into the bay, making sure that the drive connects to the hot-swap hard disk drive backplane. 4. Run any diagnostic programs to test the hard disk drive if you have. 5. Ensure that the hot-swap hard disk drive backplane is correctly seated. When it is correctly seated, the drive assemblies correctly connect to the backplane without bowing or causing movement of the backplane. 6. Ensure that the cable connection is correct. See “Mini-SAS to mini-SAS signal cable connections” on page 29. 7. Reconnect the backplane power cable and repeat step 1 through step 4. 8. Reconnect the backplane signal cable and repeat step 1 through step 4. 9. If you suspect a problem with the backplane signal cable or the backplane: <ol style="list-style-type: none"> a. Replace the affected backplane signal cable. b. Replace the affected backplane.
Multiple hard disk drives fail.	<ol style="list-style-type: none"> 1. Ensure that the cable connection is correct. See “Mini-SAS to mini-SAS signal cable connections” on page 29. 2. Reconnect the power cable(s). 3. Reconnect the signal cable(s). 4. Replace the affected signal cable(s). 5. If you suspect a problem with the backplane, replace the affected backplane.

Memory module problems

Follow the suggested actions for the corresponding symptom in the order in which they are listed until the problem is solved. If none of these actions solve the problem, see “Troubleshooting procedure” on page 153 for the subsequent steps you should check after using the information in this topic. If the problem still cannot be solved, seek technical assistance. See Chapter 8 “Getting information, help, and service” on page 159.

Notes:

- If you are instructed to remove, install, or replace any CRUs, refer to the related procedure in Chapter 6 “Installing, removing, or replacing hardware” on page 67.

- If an action step is preceded by “(Trained service technician only),” this action step is reserved for a trained service technician and must be performed only by a trained service technician.

Symptom	Action
The amount of system memory that is displayed is less than the total capacity of the installed physical memory modules and you suspect a memory module problem.	<ol style="list-style-type: none"> 1. Ensure that: <ul style="list-style-type: none"> • All memory modules are the correct type supported by the server. See “Memory module installation rules” on page 75. • You followed the memory module installation rules. See “Memory module installation rules” on page 75. • All memory modules are seated correctly and securely. • The system firmware is up-to-date. 2. Reinstall the memory modules. 3. Replace the suspect memory modules. 4. (Trained service technician only) Replace the system board.

Keyboard, mouse, and USB device problems

Follow the suggested actions for the corresponding symptom in the order in which they are listed until the problem is solved. If none of these actions solve the problem, see “Troubleshooting procedure” on page 153 for the subsequent steps you should check after using the information in this topic.

Symptom	Action
All or some keys on the keyboard do not work.	<ol style="list-style-type: none"> 1. Ensure that: <ul style="list-style-type: none"> • The USB keyboard cable is securely connected to a USB connector on the server. If the USB keyboard is connected to a USB hub, disconnect the keyboard from the hub and connect it directly to the server. • No keys are stuck. • The USB controller is enabled in the Setup Utility program. See “Using the Setup Utility program” on page 45. 2. Restart the server. 3. Replace the keyboard.
The mouse or pointing device does not work.	<ol style="list-style-type: none"> 1. Ensure that: <ul style="list-style-type: none"> • The mouse or pointing device cable is securely connected to the server. If the USB mouse or pointing device is connected to a USB hub, disconnect the mouse or pointing device from the hub and connect it directly to the server. • The mouse or pointing device is clean and no dust accumulates. • The device drivers are installed correctly. • The USB controller is enabled in the Setup Utility program. See “Using the Setup Utility program” on page 45. 2. Restart the server.

Symptom	Action
	3. Replace the mouse or pointing device.
A USB device does not work.	<ol style="list-style-type: none"> 1. Ensure that: <ul style="list-style-type: none"> • The USB cable is securely connected to the server. If the USB device is connected to a USB hub, disconnect the device from the hub and connect it directly to the server. • The device drivers are installed correctly. • The USB controller is enabled in the Setup Utility program. See “Using the Setup Utility program” on page 45. 2. Restart the server. 3. Replace the USB device.

Chapter 8. Getting information, help, and service

This chapter contains information about help, service, and technical assistance for products manufactured by Lenovo and where to go for additional information about Lenovo and Lenovo products.

Information resources

You can use the information in this topic to access useful resources relating to your needs when using the product.

Using the documentation

Information about your Lenovo system and installed software, if any, or optional devices is available in the documentation that comes with the product. The documentation can include printed documents, online documents, readme files, and help files. Most of the documentation for your server is on the documentation DVD provided with your server. Refer to the troubleshooting information in your server *User Guide* for instructions on how to diagnose problems and do basic troubleshooting. The troubleshooting and diagnostics information might tell you that you need additional or updated device drivers or other software. Lenovo maintains pages on the World Wide Web where you can get the latest technical information and download documentation or device drivers and updates. To access the Lenovo Support Web site, go to: <http://www.lenovo.com/support>

For more information about your server documentation, see “Server documentation” on page 2.

If you suspect a software problem, refer to the documentation, including readme files and online help, that comes with the operating system or software program.

ThinkServer Web site

The ThinkServer Web site provides up-to-date information and services to help you buy, use, upgrade, and maintain your server. You also can do the following by visiting the ThinkServer Web site at: <http://www.lenovo.com/thinkserver>

- Shop for servers as well as upgrades and accessories for your server.
- Purchase additional services and software.
- Purchase upgrades and extended hardware repair services.
- Access the Lenovo Limited Warranty (LLW).
- Access the online manuals for your products.
- Access troubleshooting and support information for your server model and other supported products.
- Download the latest device drivers and software updates for your server model.
- Find the service and support phone numbers for your country or region.
- Find a Service Provider located near you.

Lenovo Support Web site

Technical support information is available on the Lenovo Support Web site at: <http://www.lenovo.com/support>

This Web site is updated with the latest support information such as the following:

- Drivers and software

- Diagnostic solutions
 - Product and service warranty
 - Product and parts details
 - User guides and manuals
 - Knowledge base and frequently asked questions
-

Help and service

This topic contains information about obtaining help and service.

Before you call

Before you call, do the following to try to solve the problem by yourself:

- Check all cables to ensure that they are connected.
- Check the power switches to ensure that the system and optional devices are turned on.
- Use the troubleshooting information in your system documentation on the documentation DVD that comes with your product.
- Check for the updated information, new device drivers, and hints and tips on the Lenovo Support Web site at:
<http://www.lenovo.com/support>

If possible, be at your product when you call. Have the following information available:

- Machine type and model
- Serial numbers of your Lenovo hardware products
- Description of the problem
- Exact wording of any error messages
- Hardware and software configuration information

Calling for service

During the warranty period, you can get help and information by telephone through the Customer Support Center.

The following services are available during the warranty period:

- **Problem determination** - Trained service personnel are available to assist you with determining a hardware problem and deciding what action is necessary to fix the problem.
- **Hardware repair** - If the problem is caused by hardware under warranty, trained service personnel are available to provide the applicable level of service.
- **Engineering Change management** - There might be changes that are required after a product has been sold. Lenovo or your reseller will make selected Engineering Changes (ECs) that apply to your hardware available.

The warranty does not cover the following:

- Replacement or use of parts not manufactured for or by Lenovo or non-warranted Lenovo parts
- Identification of software problem sources
- Configuration of the Unified Extensible Firmware Interface (UEFI) BIOS as part of an installation or upgrade
- Changes, modifications, or upgrades to device drivers
- Installation and maintenance of network operating systems (NOS)
- Installation and maintenance of application programs

For the warranty type and duration for your product, refer to the *Warranty and Support Information* on the documentation DVD that comes with your server. You must retain your proof of purchase to obtain warranty service.

For warranty service, consult the worldwide Lenovo Support telephone list. Telephone numbers are subject to change without notice. The most up-to-date telephone list for Lenovo Support is always available on the Web site at <http://www.lenovo.com/support/phone>. If the telephone number for your country or region is not listed, contact your Lenovo reseller or Lenovo marketing representative.

Using other services

If you travel with a Lenovo notebook computer or relocate your computer to a country where your desktop, notebook, or server machine type is sold, your computer might be eligible for International Warranty Service, which automatically entitles you to obtain warranty service throughout the warranty period. Service will be performed by service providers authorized to perform warranty service.

Service methods and procedures vary by country, and some services might not be available in all countries. International Warranty Service is delivered through the method of service (such as depot, carry-in, or on-site service) that is provided in the servicing country. Service centers in certain countries might not be able to service all models of a particular machine type. In some countries, fees and restrictions might apply at the time of service.

To determine whether your computer is eligible for International Warranty Service and to view a list of the countries where service is available, go to <http://www.lenovo.com/support>, click **Warranty**, and follow the instructions on the screen.

For technical assistance with the installation of or questions related to Service Packs for your installed Windows product, refer to the Microsoft Product Support Services Web site at <http://support.microsoft.com/directory> or you can contact the Customer Support Center. Some fees might apply.

Purchasing additional services

During and after the warranty period, you can purchase additional services, such as support for hardware, operating systems, and application programs; network setup and configuration services; upgraded or extended hardware repair services; and custom installation services. Service availability and service names might vary by country or region. For more information about these services, go to the Lenovo Web site at: <http://www.lenovo.com>

Appendix A. Notices

Lenovo may not offer the products, services, or features discussed in this document in all countries. Consult your local Lenovo representative for information on the products and services currently available in your area. Any reference to a Lenovo product, program, or service is not intended to state or imply that only that Lenovo product, program, or service may be used. Any functionally equivalent product, program, or service that does not infringe any Lenovo intellectual property right may be used instead. However, it is the user's responsibility to evaluate and verify the operation of any other product, program, or service.

Lenovo may have patents or pending patent applications covering subject matter described in this document. The furnishing of this document does not give you any license to these patents. You can send license inquiries, in writing, to:

*Lenovo (United States), Inc.
1009 Think Place - Building One
Morrisville, NC 27560
U.S.A.
Attention: Lenovo Director of Licensing*

LENOVO PROVIDES THIS PUBLICATION "AS IS" WITHOUT WARRANTY OF ANY KIND, EITHER EXPRESS OR IMPLIED, INCLUDING, BUT NOT LIMITED TO, THE IMPLIED WARRANTIES OF NON-INFRINGEMENT, MERCHANTABILITY OR FITNESS FOR A PARTICULAR PURPOSE. Some jurisdictions do not allow disclaimer of express or implied warranties in certain transactions, therefore, this statement may not apply to you.

This information could include technical inaccuracies or typographical errors. Changes are periodically made to the information herein; these changes will be incorporated in new editions of the publication. Lenovo may make improvements and/or changes in the product(s) and/or the program(s) described in this publication at any time without notice.

The products described in this document are not intended for use in implantation or other life support applications where malfunction may result in injury or death to persons. The information contained in this document does not affect or change Lenovo product specifications or warranties. Nothing in this document shall operate as an express or implied license or indemnity under the intellectual property rights of Lenovo or third parties. All information contained in this document was obtained in specific environments and is presented as an illustration. The result obtained in other operating environments may vary.

Lenovo may use or distribute any of the information you supply in any way it believes appropriate without incurring any obligation to you.

Any references in this publication to non-Lenovo Web sites are provided for convenience only and do not in any manner serve as an endorsement of those Web sites. The materials at those Web sites are not part of the materials for this Lenovo product, and use of those Web sites is at your own risk.

Any performance data contained herein was determined in a controlled environment. Therefore, the result obtained in other operating environments may vary significantly. Some measurements may have been made on development-level systems and there is no guarantee that these measurements will be the same on generally available systems. Furthermore, some measurements may have been estimated through extrapolation. Actual results may vary. Users of this document should verify the applicable data for their specific environment.

Trademarks

Lenovo, the Lenovo logo, and ThinkServer are trademarks of Lenovo in the United States, other countries, or both.

Intel and Intel Xeon are trademarks of Intel Corporation in the United States, other countries, or both.

Internet Explorer, Microsoft, Windows, and Windows Server are trademarks of the Microsoft group of companies.

Linux is a registered trademark of Linus Torvalds.

Other company, product, or service names may be trademarks or service marks of others.

Important notes

Processor speed indicates the internal clock speed of the microprocessor; other factors also affect application performance.

CD or DVD drive speed is the variable read rate. Actual speeds vary and are often less than the possible maximum.

When referring to processor storage, real and virtual storage, or channel volume, KB stands for 1 024 bytes, MB stands for 1 048 576 bytes, and GB stands for 1 073 741 824 bytes.

When referring to hard disk drive capacity or communications volume, MB stands for 1 000 000 bytes, and GB stands for 1 000 000 000 bytes. Total user-accessible capacity can vary depending on operating environments.

Maximum internal hard disk drive capacities assume the replacement of any standard hard disk drives and population of all hard disk drive bays with the largest currently supported drives that are available from Lenovo.

Maximum memory might require replacement of the standard memory with an optional memory module.

Lenovo makes no representations or warranties with respect to non-Lenovo products. Support (if any) for the non-Lenovo products is provided by the third party, not Lenovo.

Some software might differ from its retail version (if available) and might not include user manuals or all program functionality.

Polyvinyl Chloride (PVC) cable and cord notice

WARNING: Handling the cord on this product or cords associated with accessories sold with this product will expose you to lead, a chemical known to the State of California to cause cancer, and birth defects or other reproductive harm. ***Wash hands after handling.***

Recycling information

Lenovo encourages owners of information technology (IT) equipment to responsibly recycle their equipment when it is no longer needed. Lenovo offers a variety of programs and services to assist equipment owners in recycling their IT products. For information on recycling Lenovo products, go to:
<http://www.lenovo.com/recycling>

Battery return program

This product may contain a lithium or lithium ion battery. Consult your user manual or service manual for specific battery information. The battery must be recycled or disposed of properly. Recycling facilities may not be available in your area. For information on disposal or batteries outside the United States, go to <http://www.lenovo.com/recycling> or contact your local waste disposal facility.

Battery recycling information for the United States and Canada



US & Canada Only

Battery recycling information for the European Union

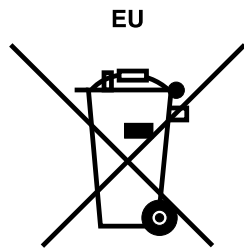

Notice: This mark applies only to countries within the European Union (EU).

Batteries or packaging for batteries are labeled in accordance with European Directive 2006/66/EC concerning batteries and accumulators and waste batteries and accumulators. The Directive determines the framework for the return and recycling of used batteries and accumulators as applicable throughout the European Union. This label is applied to various batteries to indicate that the battery is not to be thrown away, but rather reclaimed upon end of life per this Directive.

In accordance with the European Directive 2006/66/EC, batteries and accumulators are labeled to indicate that they are to be collected separately and recycled at end of life. The label on the battery may also include a chemical symbol for the metal concerned in the battery (Pb for lead, Hg for mercury, and Cd for cadmium). Users of batteries and accumulators must not dispose of batteries and accumulators as unsorted municipal waste, but use the collection framework available to customers for the return, recycling, and treatment of batteries and accumulators. Customer participation is important to minimize any potential effects of batteries and accumulators on the environment and human health due to the potential presence of hazardous substances. For proper collection and treatment, go to: <http://www.lenovo.com/recycling>

Requirement for batteries containing perchlorate

The following statement applies to users in the state of California, U.S.A.

California Perchlorate Information:

Products containing CR (manganese dioxide) lithium coin cell batteries may contain perchlorate.

Perchlorate Material - special handling may apply, See <http://www.dtsc.ca.gov/hazardouswaste/perchlorate>

Particulate contamination

Attention: Airborne particulates (including metal flakes or particles) and reactive gases acting alone or in combination with other environmental factors such as humidity or temperature might pose a risk to the server that is described in this document. Risks that are posed by the presence of excessive particulate levels or concentrations of harmful gases include damage that might cause the server to malfunction or cease functioning altogether. This specification sets forth limits for particulates and gases that are intended to avoid such damage. The limits must not be viewed or used as definitive limits, because numerous other factors, such as temperature or moisture content of the air, can influence the impact of particulates or environmental corrosives and gaseous contaminant transfer. In the absence of specific limits that are set forth in this document, you must implement practices that maintain particulate and gas levels that are consistent with the protection of human health and safety. If Lenovo determines that the levels of particulates or gases in your environment have caused damage to the server, Lenovo may condition provision of repair or replacement of servers or parts on implementation of appropriate remedial measures to mitigate such environmental contamination. Implementation of such remedial measures is a customer responsibility.

Table 6. Limits for particulates and gases

Contaminant	Limits
Particulate	<ul style="list-style-type: none"> The room air must be continuously filtered with 40% atmospheric dust spot efficiency (MERV 9) according to ASHRAE Standard 52.2¹. Air that enters a data center must be filtered to 99.97% efficiency or greater, using high-efficiency particulate air (HEPA) filters that meet MIL-STD-282. The deliquescent relative humidity of the particulate contamination must be more than 60%². The room must be free of conductive contamination such as zinc whiskers.
Gaseous	<ul style="list-style-type: none"> Copper: Class G1 as per ANSI/ISA 71.04-1985³ Silver: Corrosion rate of less than 300 Å in 30 days
<p>¹ ASHRAE 52.2-2008 - <i>Method of Testing General Ventilation Air-Cleaning Devices for Removal Efficiency by Particle Size</i>. Atlanta: American Society of Heating, Refrigerating and Air-Conditioning Engineers, Inc.</p> <p>² The deliquescent relative humidity of particulate contamination is the relative humidity at which the dust absorbs enough water to become wet and promote ionic conduction.</p> <p>³ ANSI/ISA-71.04-1985. <i>Environmental conditions for process measurement and control systems: Airborne contaminants</i>. Instrument Society of America, Research Triangle Park, North Carolina, U.S.A.</p>	

Important information for the European Directive 2002/96/EC

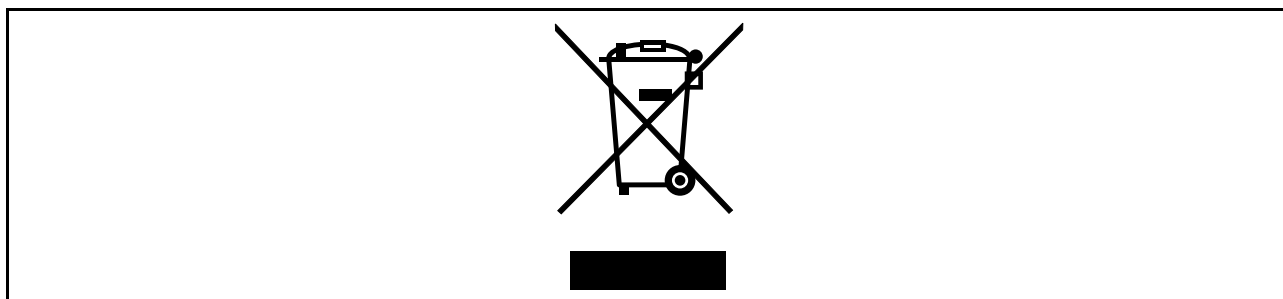

The Waste Electrical and Electronic Equipment (WEEE) mark applies only to countries within the European Union (EU) and Norway. Appliances are labeled in accordance with European Directive 2002/96/EC concerning waste electrical and electronic equipment (WEEE). The Directive determines the framework for the return and recycling of used appliances as applicable throughout the European Union. This label is applied to various products to indicate that the product is not to be thrown away, but rather reclaimed upon end of life per this Directive. Users of electrical and electronic equipment (EEE) with the WEEE marking per

Annex IV of the WEEE Directive must not dispose of end of life EEE as unsorted municipal waste, but use the collection framework available to them for the return, recycle, recovery of WEEE and minimize any potential effects of EEE on the environment and human health due to the presence of hazardous substances. For additional WEEE information go to:

<http://www.lenovo.com/recycling>

Le marquage des déchets d'équipements électriques et électroniques (DEEE) s'applique uniquement aux pays de l'Union européenne (EU) et à la Norvège. Les appareils sont marqués conformément à la Directive 2002/96/CE du Conseil Européen relative aux déchets d'équipements électriques et électroniques (DEEE). Cette directive, applicable à l'ensemble des pays de l'Union européenne, concerne la collecte et le recyclage des appareils usagés. Ce marquage est apposé sur différents produits pour indiquer que ces derniers ne doivent pas être jetés, mais récupérés en fin de vie, conformément à cette directive. Les utilisateurs d'équipements électriques et électroniques portant le marquage DEEE, conformément à l'Annexe IV de la Directive DEEE, ne doivent pas mettre au rebut ces équipements comme des déchets municipaux non triés, mais ils doivent utiliser la structure de collecte mise à disposition des clients pour le retour, le recyclage et la récupération des déchets d'équipements électriques et électroniques, afin de réduire tout effet potentiel des équipements électriques et électroniques sur l'environnement et la santé en raison de la présence possible de substances dangereuses dans ces équipements. Pour plus d'informations sur les équipements électriques et électroniques, consultez le site <http://www.lenovo.com/recycling>.

Die WEEE-Kennzeichnung gilt nur in Ländern der Europäischen Union und in Norwegen. Geräte werden gemäß der Richtlinie 2002/96/EC der Europäischen Union über Elektro- und Elektronikaltgeräte (WEEE) gekennzeichnet. Die Richtlinie regelt die Rückgabe und Wiederverwertung von Altgeräten innerhalb der Europäischen Union. Mit dieser Kennzeichnung versehene Altgeräte dürfen gemäß dieser Richtlinie nicht weggeworfen werden, sondern müssen zurückgegeben werden. Anwender von Elektro- und Elektronikgeräten mit der WEEE-Kennzeichnung dürfen diese gemäß Annex IV der WEEE-Richtlinie nach ihrem Gebrauch nicht als allgemeinen Hausmüll entsorgen. Stattdessen müssen diese Geräte im verfügbaren Sammelsystem zurückgegeben werden und damit einem Recycling- oder Wiederherstellungsprozess zugeführt werden, bei dem mögliche Auswirkungen der Geräte auf die Umwelt und den menschlichen Organismus aufgrund gefährlicher Substanzen minimiert werden. Weitere Informationen zur Entsorgung von Elektro- und Elektronikaltgeräten finden Sie unter der Adresse: <http://www.lenovo.com/recycling>.

La marca de Residuos de equipos eléctricos y electrónicos (WEEE) se aplica sólo a los países pertenecientes a la Unión Europea (UE) y a Noruega. Los aparatos se etiquetan conforme a la Directiva Europea 2002/96/EC relativa a los residuos de equipos eléctricos y electrónicos (WEEE). La directiva determina el marco para devolver y reciclar los aparatos usados según sea aplicable en toda la Unión Europea. Esta etiqueta se aplica a varios productos para indicar que el producto no se va a desechar, sino que va ser reclamado por esta Directiva, una vez termine su ciclo de vida. Los usuarios de los equipos eléctricos y electrónicos (EEE) con la marca WEEE por el Anexo IV de la Directiva WEEE no deben tratar los EEE como desperdicios municipales no clasificados, una vez terminado su ciclo de vida, sino que deben utilizar el marco de recogida disponible para devolver, reciclar y recuperar los WEEE y minimizar los posibles efectos de los EEE en el medio ambiente y en la salud debidos a la presencia de sustancias peligrosas. Para obtener información adicional acerca de WEEE consulte el sitio: <http://www.lenovo.com/recycling>.

Il marchio WEEE (Waste Electrical and Electronic Equipment) viene applicato soltanto ai paesi all'interno dell'unione europea (EU) e norvegia. Le apparecchiature vengono etichettate in accordo con la direttiva europea 2002/96/EC riguardante lo smaltimento di apparecchiatura elettrica ed elettronica (WEEE). Le direttive determinano la procedura di restituzione e di riciclaggio delle apparecchiature usate in conformità con le normative dell'unione europea. Questa classificazione viene applicata a vari prodotti per indicare che il prodotto stesso non deve essere gettato ma riscattato al termine dell'utilizzo per questa direttiva. Gli utenti di apparecchiature elettriche o elettroniche (EEE) marchiate WEEE secondo Annex IV della direttiva WEEE non devono disporre di fine utilizzo EEE come rifiuto, municipale non classificato, ma deve essere utilizzata la procedura di classificazione disponibile per il riscatto, riciclo, recupero del WEEE e minimizzare qualsiasi potenziale effetto della EEE sull'ambiente e sulla salute umana dovuto alla presenza di sostanze pericolose. Per ulteriori informazioni sulla WEEE visitare il sito: <http://www.lenovo.com/recycling>.

A marca REEE (Resíduos de Equipamentos Eléctricos e Electrónicos) aplica-se apenas aos Estados Membros da União Europeia e à Noruega. Os aparelhos eléctricos deverão ser identificados em conformidade com a Directiva Europeia 2002/96/CE relativa a REEE (Resíduos de Equipamentos Eléctricos e Electrónicos). A Directiva determina o enquadramento normativo relativamente à devolução e reciclagem de aparelhos eléctricos utilizados, conforme aplicável no espaço da União Europeia. Esta etiqueta deverá ser aposta em diversos produtos para indicar que os mesmos não poderão ser deitados fora, mas sim recuperados no final da respectiva vida útil, de acordo com a referida Directiva. Os utilizadores de equipamentos eléctricos e electrónicos (EEE) com a marca REEE em conformidade com o Anexo IV da Directiva REEE não poderão deitar fora os EEE no final da respectiva vida útil como lixo municipal não separado, devendo sim utilizar a estrutura de recolha que lhes tenha sido disponibilizada para efeitos de devolução, reciclagem e recuperação de REEE, por forma a minimizar potenciais efeitos dos EEE sobre o ambiente e saúde pública resultantes da presença de substâncias perigosas. Para obter informações adicionais acerca da REEE consulte o sítio da web: <http://www.lenovo.com/recycling>.

Het WEEE-merkteken (Waste Electrical and Electronic Equipment) geldt alleen voor landen binnen de Europese Unie (EU) en Noorwegen. Apparaten worden van een merkteken voorzien overeenkomstig Europese Richtlijn 2002/96/EC inzake afgedankte elektrische en elektronische apparatuur (waste electrical and electronic equipment, WEEE). Deze richtlijn bepaalt het raamwerk voor het retourneren en recyclen van gebruikte apparatuur, zoals van toepassing binnen de Europese Unie. Dit merkteken wordt aangebracht op diverse producten om aan te geven dat het product in kwestie niet dient te worden weggegooid, maar dat het aan het eind van de levenscyclus krachtens deze Richtlijn dient te worden geretourneerd. Gebruikers van elektrische en elektronische apparaten (EEE) welke zijn voorzien van het WEEE-merkteken zijn gehouden aan Annex IV van de WEEE Richtlijn en mogen gebruikte EEE niet weggooien als ongesorteerd afval, maar dienen gebruik te maken van het inzamelproces voor het teruggeven, recyclen en terugwinnen van WEEE dat voor hen beschikbaar is, en dienen de mogelijke effecten die EEE ten gevolge van de aanwezigheid van schadelijke stoffen kunnen hebben op het milieu en de volksgezondheid, tot een minimum te beperken. Voor meer informatie over WEEE gaat u naar: <http://www.lenovo.com/recycling>.

WEEE-mærkningerne (Waste Electrical and Electronic Equipment) gælder kun for lande i EU samt Norge. Udstyr mærkes i henhold til EU's direktiv 2002/96/EF om affald af elektrisk og elektronisk udstyr (WEEE). Direktivet fastlægger de rammer, der gælder for returnering og genbrug af brugt udstyr i EU. Mærkatene påsættes forskellige produkter for at angive, at produktet ikke må smides væk, når det er udtjent, men skal genvindes i henhold til dette direktiv. Brugere af elektrisk og elektronisk udstyr (EEE), der er mærket med WEEE-mærket som angivet i Bilag IV til WEEE-direktivet, må ikke bortskaffe brugt EEE som usorteret husholdningsaffald, men skal bruge den indsamlingsordning, der er etableret, så WEEE kan returneres, genbruges eller genvindes. Formålet er at minimere den eventuelle påvirkning af miljøet og menneskers sundhed som følge af tilstedeværelsen af skadelige stoffer. Der er flere oplysninger om affald af elektrisk og elektronisk udstyr på adressen <http://www.lenovo.com/recycling>.

Sähkö- ja elektroniikkalaiteromu (Waste electrical and electronic equipment, WEEE) -merkintä koskee vain Euroopan unionin (EU) jäsenmaita ja Norjaa. Sähkö- ja elektroniikkalaitteet merkitään Euroopan parlamentin ja neuvoston direktiivin 2002/96/EY mukaisesti. Kyseinen direktiivi määrittää Euroopan Unionin alueella käytössä olevat palautus- ja kierrätyskäytännöt. WEEE-merkintä laitteessa osoittaa, että direktiivin ohjeiden mukaan tuotetta ei tulisi hävittää sen elinkaaren päässä, vaan se tulee toimittaa uusiokäyttöön. Käyttäjien, joiden sähkö- ja elektroniikkalaitteissa on tämä sähkö- ja elektroniikkalaiteromun direktiivin liitteen IV mukainen merkintä, tulee kierrättää kyseiset laitteet käytettävissä olevien resurssien mukaan ja varmistaa, että niistä tai niissä käytetyistä materiaaleista ei aiheudu haittaa ympäristölle tai ihmisten terveydelle. Sähkö- ja elektroniikkalaitteita ei saa hävittää sekajätteen mukana. Lisätietoja sähkö- ja elektroniikkalaiteromun uusiokäytöstä on WWW-sivustossa <http://www.lenovo.com/recycling>.

WEEE-merket (Waste Electrical and Electronic Equipment) gjelder bare for land i Den europeiske union (EU) og Norge. Utstyr merkes i henhold til EU-direktiv 2002/96/EF om avfall fra elektrisk og elektronisk utstyr (WEEE). Direktivet fastsetter rammene for retur og resirkulering av brukt utstyr innenfor EU. Dette merket benyttes på forskjellige produkter for å angi at produktet ikke må kastes, men må behandles i henhold til dette direktivet ved slutten av produktets levetid. Brukere av elektrisk og elektronisk utstyr

(EEE) som er merket med WEEE-merket ifølge vedlegg IV i WEEE-direktivet, må ikke kaste utstyret som usortert husholdningsavfall, men må bruke de tilgjengelige innsamlingsystemene for retur, resirkulering og gjenvinning av kassert elektrisk og elektronisk utstyr for å redusere en eventuell skadelig virkning av elektrisk og elektronisk utstyr på miljø og helse, som skyldes skadelige stoffer. Du finner mer informasjon om WEEE på denne adressen: <http://www.lenovo.com/recycling>.

Značka odpadní elektrická a elektronická zařízení (OEEZ; Waste Electrical and Electronic Equipment - WEEE) se týká pouze zemí Evropské Unie (EU) a Norska. Zařízení jsou označena v souladu s evropskou směrnicí 2002/96/EC, která se týká likvidace starých elektrických a elektronických zařízení (OEEZ). Směrnice určuje pravidla pro vracení a recyklaci použitých zařízení, která jsou platná v Evropské Unii. Tímto štítkem se označují různá zařízení. Označuje, že produkt nesmí být vyhozen do běžného odpadu, ale po skončení životnosti vrácen podle této směrnice. Uživatelé takovýchto zařízení označených značkou OEEZ podle dodatku IV směrnice OEEZ nesmí na konci životnosti vyhodit zařízení jako netříděný odpad, ale musí použít dostupnou sběrnou síť, aby bylo zařízení recyklováno a aby byly minimalizovány možné dopady zařízení na prostředí a zdraví lidí (zařízení může obsahovat nebezpečné látky). Další informace o značce OEEZ (WEEE) naleznete na webové stránce: <http://www.lenovo.com/recycling>.

廃電気電子機器指令 (WEEE) マークは EU 諸国とノルウェーにのみ適用されます。この機器には、EU 諸国に対する廃電気電子機器指令 2002/96/EC (WEEE) のラベルが貼られています。この指令は、EU 諸国に適用する使用済み機器の回収とリサイクルの骨子を定めています。このラベルは、使用済みになった時に指令に従って適正な処理をする必要があることを知らせるために種々の製品に貼られています。WEEE 指令の付則 (Annex) IV 規則によりマークされた電気/電子機器 (EEE) の使用者は、使用済みの電気・電子機器を地方自治体の無分別ゴミとして廃棄することは許されず、機器に含まれる有害物質が環境や人体へ与える悪影響を最小に抑えるためにお客様が利用可能な廃電気・電子機器の返却、リサイクル、あるいは再生のための回収方法を利用しなければなりません。WEEE の詳細については、次のWebサイトを参照してください。
<http://www.lenovo.com/recycling>

To sήμα WEEE (Waste Electrical and Electronic Equipment) χρησιμοποιείται μόνο σε χώρες της Ευρωπαϊκής Ένωσης και στη Νορβηγία. Στις συσκευές τοποθετούνται ετικέτες που αφορούν την απόρριψη ηλεκτρικών και ηλεκτρονικών εξαρτημάτων σύμφωνα με την Ευρωπαϊκή Οδηγία 2002/96/EC. Η Οδηγία αυτή καθορίζει το πλαίσιο για την επιστροφή και την ανακύκλωση χρησιμοποιημένων συσκευών που ισχύει σε όλη την Ευρωπαϊκή Ένωση. Η ετικέτα τοποθετείται σε διάφορα προϊόντα για να υποδείξει ότι μετά το μόνιμο τερματισμό της χρήσης του το προϊόν, σύμφωνα με την Οδηγία, πρέπει να απορριφθεί και όχι να απορριφθεί. Οι χρήστες ηλεκτρικών και ηλεκτρονικών εξαρτημάτων (electrical and electronic equipment - EEE) που φέρουν το σήμα WEEE σύμφωνα με το Παράρτημα IV της εν λόγω Οδηγίας, δεν πρέπει να απορρίπτουν τα εξαρτήματα αλλά να χρησιμοποιούν το διαθέσιμο πλαίσιο συλλογής για την επιστροφή, ανακύκλωση και ανάκτηση των εξαρτημάτων με σκοπό την ελαχιστοποίηση δυνητικών επιρροών στο περιβάλλον και την ανθρώπινη υγεία εξαιτίας της παρουσίας επικίνδυνων ουσιών στα εξαρτήματα αυτά. Για περισσότερες πληροφορίες σχετικά με τις κατάλληλες ενέργειες συλλογής και κατεργασίας ηλεκτρονικών συσκευών και εξαρτημάτων, επισκεφθείτε την ιστοσελίδα: <http://www.lenovo.com/recycling>.

A WEEE (leselejtezett elektromos és elektronikus berendezések) jelzés csak az EU tagállamaira és Norvégiára vonatkozik. A berendezések a leselejtezett elektromos és elektronikus berendezésekre (WEEE) vonatkozó 2002/96/EC számú EU direktívának való megfelelést tanúsító címkével vannak ellátva. A direktíva a használt berendezések visszavételének és újrahasznosításának keretrendszerét határozza meg az Európai Unión belül. A különböző termékeken látható címke azt jelenti, hogy a terméket az élettartamának végén nem szabad kidobni, hanem a direktívának megfelelően kell visszanyerni. A WEEE jelzésű elektromos és elektronikai felszerelések (EEE) felhasználóinak, a WEEE direktíva IV. függelékének megfelelően nem szabad vegyes házi szemétként kidobniuk az eszközöket (EEE), hanem a vásárlók számára rendelkezésre álló, meglévő begyűjtési keretrendszer felhasználva kell gondoskodniuk az elektromos hulladék (WEEE) visszajuttatásáról és újrahasznosításáról, valamint minimalizálniuk kell az eszközök (EEE) lehetséges hatásait a környezetre és az emberi egészségre, a veszélyek megelőzése érdekében. További WEEE információk: <http://www.lenovo.com/recycling>.

German Ordinance for Work gloss statement

The product is not suitable for use with visual display work place devices according to clause 2 of the German Ordinance for Work with Visual Display Units.

Das Produkt ist nicht für den Einsatz an Bildschirmarbeitsplätzen im Sinne § 2 der Bildschirmarbeitsverordnung geeignet.

Export classification notice

This product is subject to the United States Export Administration Regulations (EAR) and has an Export Classification Control Number (ECCN) of 4A994.b. It can be re-exported except to any of the embargoed countries in the EAR E1 country list.

Electronic emission notices

The following information refers to the Lenovo ThinkServer machine types 3072, 3073, 3074, 4302, 4304, and 4305.

Federal Communications Commission (FCC) Statement

This equipment has been tested and found to comply with the limits for a Class A digital device, pursuant to Part 15 of the FCC Rules. These limits are designed to provide reasonable protection against harmful interference when the equipment is operated in a commercial environment. This equipment generates, uses, and can radiate radio frequency energy and, if not installed and used in accordance with the instruction manual, may cause harmful interference to radio communications. Operation of this equipment in a residential area is likely to cause harmful interference in which case the user will be required to correct the interference at his own expense.

Properly shielded and grounded cables and connectors must be used in order to meet FCC emission limits. Lenovo is not responsible for any radio or television interference caused by using other than specified or recommended cables and connectors or by unauthorized changes or modifications to this equipment. Unauthorized changes or modifications could void the user's authority to operate the equipment.

This device complies with Part 15 of the FCC Rules. Operation is subject to the following two conditions: (1) this device may not cause harmful interference, and (2) this device must accept any interference received, including interference that may cause undesired operation.

Industry Canada Class A emission compliance statement

This Class A digital apparatus complies with Canadian ICES-003.

Cet appareil numérique de la classe A est conforme à la norme NMB-003 du Canada.

United Kingdom telecommunications safety requirement

Notice to Customers

This apparatus is approved under approval number NS/G/1234/J/100003 for indirect connection to public telecommunication systems in the United Kingdom.

European Union - Compliance to the Electromagnetic Compatibility Directive

This product is in conformity with the protection requirements of EU Council Directive 2004/108/EC on the approximation of the laws of the Member States relating to electromagnetic compatibility. Lenovo cannot accept responsibility for any failure to satisfy the protection requirements resulting from a non-recommended modification of the product, including the installation of option cards from other manufacturers.

This product has been tested and found to comply with the limits for Class A Information Technology Equipment according to European Standard EN 55022. The limits for Class A equipment were derived for commercial and industrial environments to provide reasonable protection against interference with licensed communication equipment.



Warning: This is a Class A product. In a domestic environment this product may cause radio interference in which case the user may be required to take adequate measures.

German Class A compliance statement

Deutschsprachiger EU Hinweis:

Hinweis für Geräte der Klasse A EU-Richtlinie zur Elektromagnetischen Verträglichkeit

Dieses Produkt entspricht den Schutzanforderungen der EU-Richtlinie 2004/108/EG (früher 89/336/EWG) zur Angleichung der Rechtsvorschriften über die elektromagnetische Verträglichkeit in den EU-Mitgliedsstaaten und hält die Grenzwerte der EN 55022 Klasse A ein.

Um dieses sicherzustellen, sind die Geräte wie in den Handbüchern beschrieben zu installieren und zu betreiben. Des Weiteren dürfen auch nur von der Lenovo empfohlene Kabel angeschlossen werden. Lenovo übernimmt keine Verantwortung für die Einhaltung der Schutzanforderungen, wenn das Produkt ohne Zustimmung der Lenovo verändert bzw. wenn Erweiterungskomponenten von Fremdherstellern ohne Empfehlung der Lenovo gesteckt/eingebaut werden.

Deutschland:

Einhaltung des Gesetzes über die elektromagnetische Verträglichkeit von Betriebsmitteln

Dieses Produkt entspricht dem „Gesetz über die elektromagnetische Verträglichkeit von Betriebsmitteln“ EMVG (früher „Gesetz über die elektromagnetische Verträglichkeit von Geräten“). Dies ist die Umsetzung der EU-Richtlinie 2004/108/EG (früher 89/336/EWG) in der Bundesrepublik Deutschland.

Zulassungsbescheinigung laut dem Deutschen Gesetz über die elektromagnetische Verträglichkeit von Betriebsmitteln, EMVG vom 20. Juli 2007 (früher Gesetz über die elektromagnetische Verträglichkeit von Geräten), bzw. der EMV EG Richtlinie 2004/108/EC (früher 89/336/EWG), für Geräte der Klasse A.

Dieses Gerät ist berechtigt, in Übereinstimmung mit dem Deutschen EMVG das EG-Konformitätszeichen - CE - zu führen. Verantwortlich für die Konformitätserklärung nach Paragraf 5 des EMVG ist die Lenovo (Deutschland) GmbH, Gropiusplatz 10, D-70563 Stuttgart.

Informationen in Hinsicht EMVG Paragraf 4 Abs. (1) 4:

Das Gerät erfüllt die Schutzanforderungen nach EN 55024 und EN 55022 Klasse A.

Nach der EN 55022: „Dies ist eine Einrichtung der Klasse A. Diese Einrichtung kann im Wohnbereich Funkstörungen verursachen; in diesem Fall kann vom Betreiber verlangt werden, angemessene Maßnahmen durchzuführen und dafür aufzukommen.“

Nach dem EMVG: „Geräte dürfen an Orten, für die sie nicht ausreichend entstört sind, nur mit besonderer Genehmigung des Bundesministers für Post und Telekommunikation oder des Bundesamtes für Post und Telekommunikation betrieben werden. Die Genehmigung wird erteilt, wenn keine elektromagnetischen Störungen zu erwarten sind.“ (Auszug aus dem EMVG, Paragraph 3, Abs. 4). Dieses Genehmigungsverfahren ist nach Paragraph 9 EMVG in Verbindung mit der entsprechenden Kostenverordnung (Amtsblatt 14/93) kostenpflichtig.

Anmerkung: Um die Einhaltung des EMVG sicherzustellen sind die Geräte, wie in den Handbüchern angegeben, zu installieren und zu betreiben.

ENERGY STAR model information



ENERGY STAR® is a joint program of the U.S. Environmental Protection Agency and the U.S. Department of Energy aimed at saving money and protecting the environment through energy efficient products and practices.

Lenovo is proud to offer our customers products with an ENERGY STAR compliant designation. Some models of the following machine types have been designed and tested to conform to the ENERGY STAR program requirement for computer servers at the time of manufacture: 3072, 3073, 3074, 4302, 4304, and 4305.

For more information about ENERGY STAR ratings for Lenovo servers, go to <http://www.lenovo.com>.

By using ENERGY STAR compliant products and taking advantage of the power-management features of your server, you reduce the consumption of electricity. Reduced electrical consumption contributes to potential financial savings, a cleaner environment, and the reduction of greenhouse gas emissions.

For more information about ENERGY STAR, go to:
<http://www.energystar.gov>

Lenovo encourages you to make efficient use of energy an integral part of your day-to-day operations. To help in this endeavor, set the following power-management features to take effect when your servers have been used:

- Processor- or core-reduced power states
- Variable speed fan control based on power or thermal readings
- Low power memory states
- Liquid cooling capability

Index

- 2.5-inch hard disk drive backplane
 - locations 28
- 3.5-inch hard disk drive backplane
 - locations 27

A

- about RAID 56
- Advanced menu
 - Setup Utility program 46
- advanced SATA/SAS hardware RAID
 - configuring 63
- ambient temperature limit LED
 - LED 20

B

- BIOS and TMM update utilities
 - software 12
- Boot Manager menu
 - Setup Utility program 48
- Boot Options menu
 - Setup Utility program 48

C

- cable connection 29
- configuring
 - Ethernet controllers 64
 - server 45
- configuring RAID
 - advanced SATA/SAS hardware RAID 63
 - ThinkServer RAID 300 58
 - using the ThinkServer EasyStartup program 58
- configuring the server 45
- considerations, password 49
- consistency check
 - running 62
- contamination, particulate and gaseous 166
- cooling shroud
 - reinstalling 74
 - removing 73
- creating, adding, or deleting
 - RAID array 60
- CRU
 - completing the replacement 147

D

- devices, handling static-sensitive 68
- DIMM
 - installation rules 75
 - installing 78
 - removing 80
- documentation

- using 159

E

- EasyUpdate Firmware Updater program
 - using 64
- error
 - LED 19
- error LEDs
 - system fan 41
- Ethernet card
 - installing 81
 - removing 83
- Ethernet connectivity
 - features 9
- Ethernet connector 0
 - Setup Utility program 51
- Ethernet controllers
 - configuring 64
- Ethernet status
 - LED 21
- exiting
 - Setup Utility program 51
- expansion slots
 - features 8
- export classification notice 170

F

- features 7
 - ThinkServer EasyStartup program 53
- firmware
 - updating 64
- flashing
 - the BIOS 52
- front panel
 - LED 17
 - locations 17
- front panel board
 - replacing 141
- front view of the server
 - locations 14

G

- gaseous contamination 166
- German gloss statement 170
- getting help 159
- getting information 159
- getting service 159
- guidelines 67

H

- hardware

- installing 67
- removing 67
- replacing 67
- heat sink
 - installing or replacing 110
- help, getting 159
- hot-spare drive
 - setting 61
- hot-swap hard disk drive
 - installing 122
 - replacing 122
- hot-swap hard disk drive backplane
 - locations 27
 - replacing 132
- hot-swap hard disk drive status
 - LED 25
- hot-swap hard disk drive status LEDs
 - locations 25
- hot-swap redundant power supply
 - installing 107
 - replacing 109
- hot-swap redundant power supply status
 - LED 21

I

- ID button
 - LED 18
- IDM
 - replace 137
- IDM panel
 - LED 19
 - locations 19
- information, getting 159
- initializing
 - virtual drive 61
- Input/Output (I/O)
 - features 8
- installation rules
 - DIMM 75
 - memory module 75
- installing
 - DIMM 78
 - Ethernet card 81
 - hardware 67
 - hot-swap hard disk drive 122
 - hot-swap redundant power supply 107
 - memory module 78
 - microprocessor 113
 - RAID card 85
 - server cover 147
 - ThinkServer Trusted Platform Module 103
 - TMM Premium 100
 - TR 300 Key 96
 - TR 500 Key 89
 - TR 700 Battery 93
- installing and using
 - MegaRAID Storage Manager program 63
- installing or replacing
 - heat sink 110

- optical drive 126
- Intelligent Diagnostics Module
 - locations 19
- interface
 - LSI Software RAID Configuration Utility program 59
 - Setup Utility program 46
- internal drives
 - features 8

L

- LED
 - ambient temperature limit LED 20
 - error 19
 - Ethernet status 21
 - front panel 17
 - hot-swap hard disk drive status 25
 - hot-swap redundant power supply status 21
 - ID button 18
 - IDM 19
 - NIC status 18
 - power status 18
 - system board 39
 - system status 18
 - ThinkServer Management Module status 40
- Lenovo Rack Planner
 - software 12
- Lenovo ThinkServer EasyManage
 - software 12
- Lenovo ThinkServer EasyManage program
 - using 65
- locations 13
- low-profile
 - PCI Express card slot 21
- LSI Software RAID Configuration Utility program
 - interface 59
 - starting 59

M

- machine type and model label
 - locations 13
- Main menu
 - Setup Utility program 46
- MegaRAID Storage Manager program
 - installing and using 63
- memory
 - features 8
- memory module
 - installation rules 75
 - installing 78
 - removing 80
- memory module installation
 - guidelines 75
- microprocessor
 - features 8
 - installing 113
 - replacing 118

N

NIC status
LED 18

O

optical drive
installing or replacing 126
option
completing the replacement 147

P

particulate contamination 166
parts replacement, completing 147
password
considerations 49
setting, changing, deleting 49
Setup Utility program 49
PCI Express card slot
low-profile 21
physical drive
rebuilding 62
power status
LED 18
power supply
features 8
precautions
guidelines 67

R

RAID
configuring 56
introduction 56
RAID array
creating, adding, or deleting 60
RAID array status 58
RAID card
installing 85
locations 25
removing 88
RAID configuration utilities
software 12
rear view of the server
locations 20
rebuilding
physical drive 62
recovering
the BIOS 52
reinstalling
cooling shroud 74
reliability, availability, and serviceability
features 9
remote management
software 12
removing
cooling shroud 73
DIMM 80
Ethernet card 83

hardware 67
memory module 80
RAID card 88
server cover 69
ThinkServer Trusted Platform Module 104
TMM Premium 101
TR 300 Key 97
TR 500 Key 91
TR 700 Battery 94
replace
IDM 137
replacing
front panel board 141
hardware 67
hot-swap hard disk drive 122
hot-swap hard disk drive backplane 132
hot-swap redundant power supply 109
microprocessor 118
riser card assembly 1 143
system board battery 145
system fan 139
riser card assembly 1
replacing 143
road map
server setup 5
running
consistency check 62

S

Save & Exit menu
Setup Utility program 48
Security menu
Setup Utility program 47
serial number label
locations 13
server components
locations 22
server configuration
updating 151
server cover
installing 147
removing 69
server documentation 2
Server Management menu
Setup Utility program 47
server package 7
server setup
road map 5
service, getting 159
setting
hot-spare drive 61
setting, changing, deleting
password 49
Setup Utility program
Ethernet connector 0 51
exiting 51
interface 46
password 49
starting 45

- TPM 50
 - using 45
- slim optical drive
 - locations 15, 17
- software 11
- specifications 11
- starting
 - LSI Software RAID Configuration Utility program 59
 - Setup Utility program 45
 - ThinkServer EasyStartup program 54
- startup device
 - selecting 50
 - Setup Utility program 50
- static-sensitive devices
 - guidelines 68
- static-sensitive devices, handling 68
- system board 31
 - LED 39
- system board battery
 - replacing 145
- system board components
 - locations 31
- system board jumpers and switches
 - locations 34
- system board LEDs
 - locations 39
- system date
 - setting 48
- system event log
 - troubleshooting and diagnostics 153
- system fan
 - replacing 139
- system fan error LEDs
 - LED 41
- system fans
 - features 8
- system reliability
 - guidelines 69
- system status
 - LED 18
- system time
 - setting 48

T

- the BIOS
 - flashing 52
 - recovering 52
 - updating 52
 - updating or recovering 51
- ThinkServer EasyStartup
 - software 11
- ThinkServer EasyStartup program
 - features 53
 - starting 54
 - using 53
 - Windows operating system 55
- ThinkServer EasyUpdate Firmware Updater
 - software 12
- ThinkServer Management Module status

- LED 40
- ThinkServer RAID 300
 - configuring 58
- ThinkServer Smart Grid Technology
 - software 12
- ThinkServer Trusted Platform Module
 - installing 103
 - removing 104
- ThinkServer Web address 1
- TMM Premium
 - installing 100
 - removing 101
- TPM
 - Setup Utility program 50
- TR 300 Key
 - installing 96
 - removing 97
- TR 500 Key
 - installing 89
 - removing 91
- TR 700 Battery
 - installing 93
 - removing 94
- troubleshooting and diagnostics
 - hard disk drive problems 155
 - keyboard, mouse, and USB device problems 157
 - memory module problems 156
 - optical drive problems 154
 - status and diagnostic LEDs 153
 - system event log 153
 - ThinkServer EasyStartup program problems 154
 - troubleshooting procedure 153
- turning off the server 43
- turning on the server 43
- TÜV gloss statement 170

U

- updating
 - firmware 64
 - server configuration 151
 - the BIOS 52
- updating or recovering
 - the BIOS 51
- using
 - documentation 159
 - EasyUpdate Firmware Updater program 64
 - Lenovo ThinkServer EasyManage program 65
 - passwords 49
 - Setup Utility program 45
 - ThinkServer EasyStartup program 53

V

- video subsystem
 - features 9
- viewing information
 - Setup Utility program 45
- virtual drive

initializing 61

W

Web site

compatible options 75–76

working inside the server with the power on
guidelines 69

lenovo®