

# Switching (30V, 3.5A)

## RDS035L03

### ●Features

- 1) Low Qg.
- 2) Low on-resistance.
- 3) Excellent resistance to damage from static electricity.

### ●Application

Switching

### ●Structure

Silicon N-channel  
MOS FET

### ●External dimensions (Units : mm)

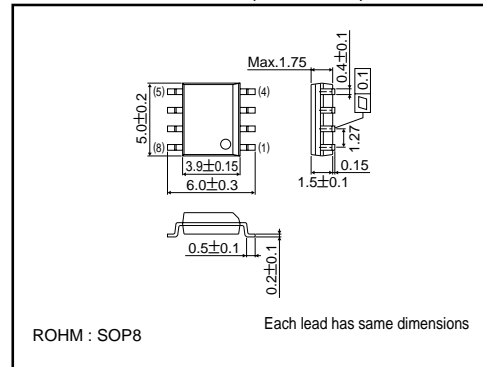

### ●Equivalent circuit

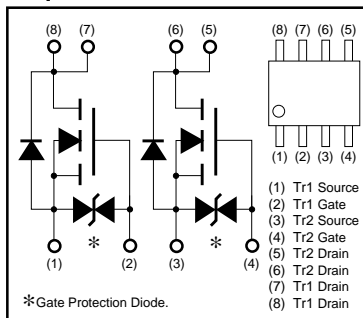

\* A protection diode is included between the gate and the source terminals to protect the diode against static electricity when the product is in use. Use a protection circuit when the fixed voltage are exceeded.

### ●Absolute maximum ratings (Ta=25°C)

Parameter	Symbol	Limits	Unit	
Drain-Source Voltage	$V_{DSS}$	30	V	
Gate-Source Voltage	$V_{GSS}$	±20	V	
Drain Current	Continuous	$I_D$	3.5	A
	Pulsed	$I_{DP}^*$	14	A
Reverse Drain Current	Continuous	$I_{DR}$	3.5	A
	Pulsed	$I_{DRP}^*$	14	A
Source Current (Body Diode)	Continuous	$I_S$	1.3	A
	Pulsed	$I_{SP}^*$	5.2	A
Total Power Dissipation(Tc=25°C)	$P_D$	2	W	
Channel Temperature	$T_{ch}$	150	°C	
Storage Temperature	$T_{stg}$	-55~+150	°C	

\*  $P_w \leq 10ms$ , Duty cycle  $\leq 1\%$

## Transistors

## ● Thermal resistance (Ta=25°C)

Parameter	Symbol	Limits	Unit
Channel to Ambient	Rth(ch-A)	62.5	°C / W

## ● Electrical characteristics (Ta=25°C)

Parameter	Symbol	Min.	Typ.	Max.	Unit	Test Conditions
Gate-Source Leakage	I <sub>GSS</sub>	–	–	±10	μA	V <sub>GS</sub> =±20V, V <sub>DS</sub> =0V
Drain-Source Breakdown Voltage	V <sub>(BR)DSS</sub>	30	–	–	V	I <sub>D</sub> =1mA, V <sub>GS</sub> =0V
Zero Gate Voltage Drain Current	I <sub>DSS</sub>	–	–	10	μA	V <sub>DS</sub> =30V, V <sub>GS</sub> =0V
Gate Threshold Voltage	V <sub>GS(th)</sub>	1.0	–	2.5	V	V <sub>DS</sub> =10V, I <sub>D</sub> =1mA
Static Drain-Source On-State Resistance	R <sub>DS(on)</sub>	–	62	80	mΩ	I <sub>D</sub> =3.5A, V <sub>GS</sub> =10V
		–	105	134		I <sub>D</sub> =3.5A, V <sub>GS</sub> =4.5V
		–	132	172		I <sub>D</sub> =3.5A, V <sub>GS</sub> =4V
Forward Transfer Admittance	Y <sub>fs</sub>  *	2.5	–	–	S	I <sub>D</sub> =3.5A, V <sub>DS</sub> =10V
Input Capacitance	C <sub>iss</sub>	–	180	–	pF	V <sub>DS</sub> =10V
Output Capacitance	C <sub>oss</sub>	–	95	–	pF	V <sub>GS</sub> =0V
Reverse Transfer Capacitance	C <sub>rss</sub>	–	38	–	pF	f=1MHz
Turn-On Delay Time	t <sub>d(on)</sub> *	–	6	–	ns	I <sub>D</sub> =2A, V <sub>DD</sub> =15V
Rise Time	t <sub>r</sub> *	–	12	–	ns	V <sub>GS</sub> =10V
Turn-Off Delay Time	t <sub>d(off)</sub> *	–	20	–	ns	R <sub>L</sub> =7.5Ω
Fall Time	t <sub>f</sub> *	–	6	–	ns	R <sub>GS</sub> =10Ω
Total Gate Charge	Q <sub>g</sub> *	–	6.5	–	nC	V <sub>DD</sub> =15V
Gate-Source Charge	Q <sub>gs</sub> *	–	1.2	–	nC	V <sub>GS</sub> =10V
Gate-Drain Charge	Q <sub>gd</sub> *	–	1.8	–	nC	I <sub>D</sub> =3.5A

\* Pulsed

## ● Body diode characteristics (Source-Drain Characteristics) (Ta=25°C)

Parameter	Symbol	Min.	Typ.	Max.	Unit	Test Conditions
Forward Voltage	V <sub>SD</sub> *	–	–	1.5	V	I <sub>S</sub> =3.5A, V <sub>GS</sub> =0V
Reverse Recovery Time	t <sub>rr</sub> *	–	26	–	ns	I <sub>DR</sub> =3.5A, V <sub>GS</sub> =0V
Reverse Recovery Charge	Q <sub>rr</sub> *	–	24	–	nC	di/dt=50A/μs

\* Pulsed

Transistors

●Electrical characteristic curves

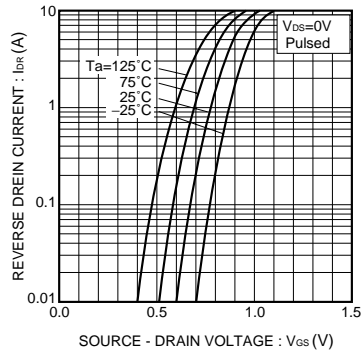

Fig.1 Reverse Drain Current vs. Source - Drain Voltage

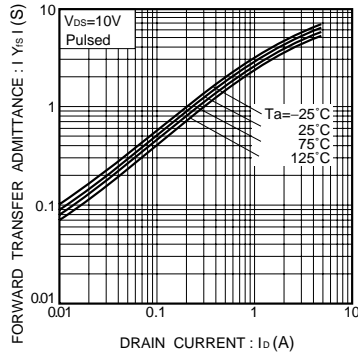

Fig.2 Forward Transfer Admittance vs. Drain Current

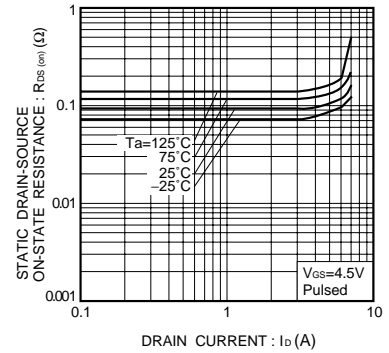

Fig.3 Static Drain-Source On-State Resistance vs. Drain Current (I)

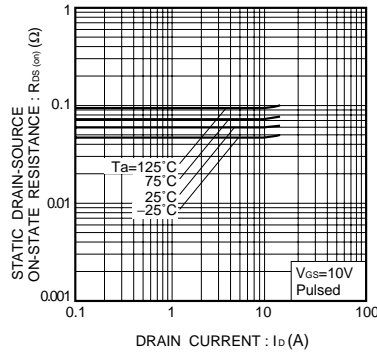

Fig.4 Static Drain-Source On-State Resistance vs. Drain Current (II)

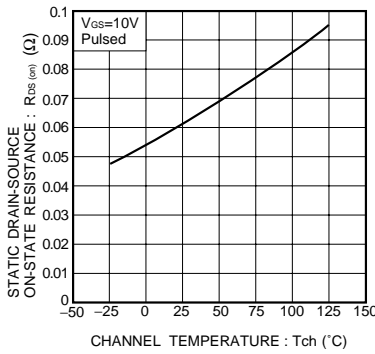

Fig.5 Static Drain-Source On-State Resistance vs. Channel Temperature

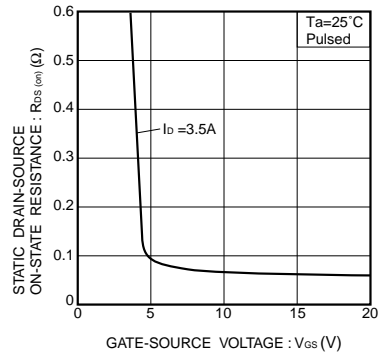

Fig.6 Static Drain-Source On-State Resistance vs. Gate-Source Voltage

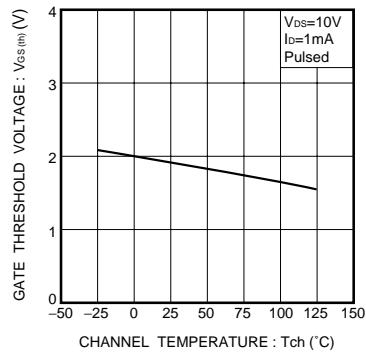

Fig.7 Gate Threshold Voltage vs. Channel Temperature

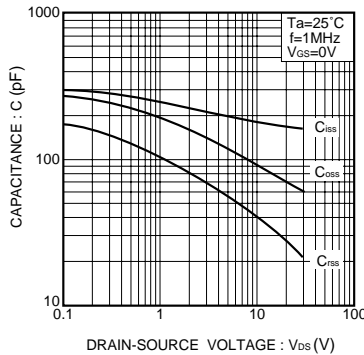

Fig.8 Typical Capacitance vs. Drain-Source Voltage

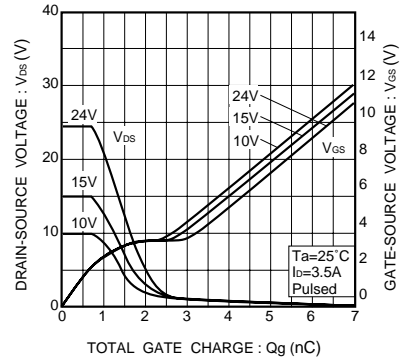

Fig.9 Dynamic Input Characteristics

Transistors

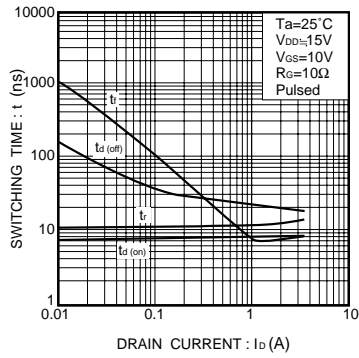

Fig.10 Switching Characteristics

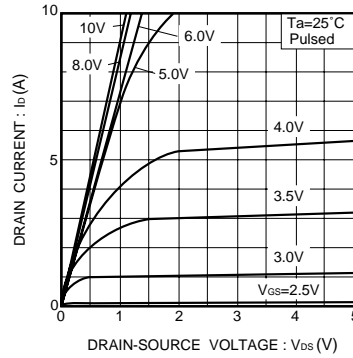

Fig.11 Typical Output Characteristics

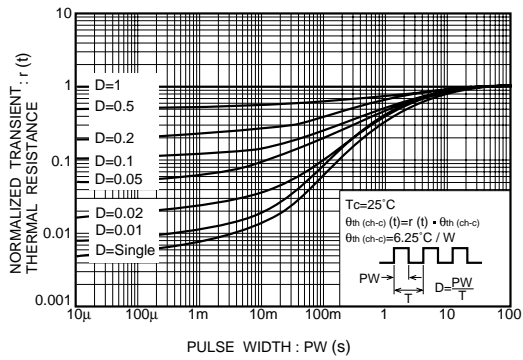

Fig.12 Normalized Transient Thermal Resistance vs. Pulse Width