



OKAYA

OKAYA Electric America, Inc.

SPECIFICATIONS

SAMPLE CODE

SE9664WRF-004-I02Q

MASS PRODUCTION CODE

RE9664WRF-004-I02

DRAWING NO.

Customer Approved
Date:

Sales Sign	QC Confirmed	Checked By	Designer

Approval For Specifications Only.

* This specification is subject to change without notice.

Approval For Specifications and Sample.



Phone: 219-477-4488
Fax: 219-477-4856
www.okaya.com



OKAYA ELECTRIC AMERICA
52 Marks Road, Suite 1
Valparaiso, Indiana 46383

History of Version

Date (mm / dd / yyyy)	Ver.	Edi.	Description	Page	Design by
06/01/2010	01	001	New Drawing	-	Lori

Contents

1. SPECIFICATIONS

- 1.1 Features**
- 1.2 Mechanical Specifications**
- 1.3 Absolute Maximum Ratings**
- 1.4 DC Electrical Characteristics**
- 1.5 Optical Characteristics**
- 1.6 Backlight Characteristics**

2. MODULE STRUCTURE

- 2.1 Counter Drawing**
- 2.2 Interface Pin Description**
- 2.3 Timing Characteristics**
- 2.4 Display Command**

3. QUALITY ASSURANCE SYSTEM

- 3.1 Quality Assurance Flow Chart**
- 3.2 Inspection Specification**

4. RELIABILITY TEST

- 4.1 Reliability Test Condition**

5. PRECAUTION RELATING PRODUCT HANDLING

- 5.1 Safety**
- 5.2 Handling**
- 5.3 Storage**
- 5.4 Terms of Warranty**

Appendix: LCM Drawing

1. SPECIFICATIONS

1.1 Features

Item	Standard Value
Display Type	96*64 Dots
LCD Type	FSTN, Positive, Transflective, Extended Temp.
Driver Condition	LCD Module : 1/68Duty , 1/9Bias
Viewing Direction	6 O'clock
Backlight	White LED B/L
Weight	TBD
Interface	4-Line interface
Other(controller / driver IC)	ST7579
ROHS	THIS PRODUCT CONFORMS THE ROHS OF

1.2 Mechanical Specifications

Item	Standard Value	Unit
Outline Dimension	33.35(W)*41.64(L)*3.0(H)MAX	mm
Viewing Area	29.3 (W)* 29.9 (L)	mm
Active Area	27.34(W)*26.86(L)	mm
Dot Size	0.265(L)*0.400(W)	mm
Dot Pitch	0.285(L)*0.420(W)	mm

Note : For detailed information please refer to LCM drawing

1.3 Absolute Maximum Ratings

Item	Symbol	Condition	Min.	Max.	Unit
Power Supply Voltage	VDD	-	-0.3	3.6	V
LCD Driver Supply Voltage	V _{LCD}	-	-0.5	15.0	V
Operating Temperature	T _{OP}	-	-20	70	°C
Storage Temperature	T _{ST}	-	-30	80	°C
Storage Humidity	H _D	Ta < 60 °C	-	90	%RH

1.4 DC Electrical Characteristics

Ta = 25°C

Item	Symbol	Condition	Min.	Typ.	Max.	Unit
Logic Supply Voltage	V _{DD}	-	2.4	3.3	3.4	V
“H” Input Voltage	V _{IH}	-	0.7V _{DD}	-	V _{DD}	V
“L” Input Voltage	V _{IL}	-	V _{SS}	-	0.3V _{DD}	V
“H” Output Voltage	V _{OH}	-	0.8V _{DD}	-	V _{DD}	V
“L” Output Voltage	V _{OL}	-	V _{SS}	-	0.2V _{DD}	V
Supply Current	I _{DD}	V _{DD} =3.0V; V _{OP} =TBDV; Pattern= Horizontal line*1	-	TBD	TBD	mA
LCM Driver Voltage	V _{OP} *2	-20°C	TBD	TBD	TBD	V
		25°C	TBD	TBD	TBD	
		70°C	TBD	TBD	TBD	

NOTE: *1 The Maximum current display

*2 The VOP test point is V0-XV0.

1.5 Optical Characteristics

LCD Panel: 1/68Duty, 1/9Bias, V_{LCD}=8.4V, T_a =25°C

Item		Symbol	Conditions	Min.	Typ.	Max.	Unit	Reference
Response Time	Rise	tr		-	120	180	ms	Note2
	Fall	tf		-	220	330		
Viewing angle range	Top	∅Y+	C _≥ 2.0, ∅ = 270°	-	40	-	Deg.	Notes 1
	Bottom	∅Y-		-	40	-		
	Left	∅X-		-	35	-		
	Right	∅X+		-	35	-		
Contrast Ratio		C	θ = 0°, ∅ = 270°	-	3.65	-	-	Note 3
Average Brightness (with LCD) *2		IV	IF=40mA	TBD	TBD	-	cd/m ²	Note 4
CIE Color Coordinate (With LCD) *2		X		TBD	TBD	TBD	-	
		Y		TBD	TBD	TBD	-	
Uniformity *1		△B		70	-	-	%	

Note4:

*1 : $\Delta B = B(\text{min}) / B(\text{max}) * 100\%$

*2 : Measurement Condition for Optical Characteristics:

a : Environment: 25°C ± 5°C / 60 ± 20% R.H , no wind , dark room below 10 Lux at typical lamp current and typical operating frequency.

b : Measurement Distance: 500 ± 50 mm , (θ = 0°)

c : Equipment: TOPCON BM-7 fast , (field 1°) , after 10 minutes operation.

d : The uncertainty of the C.I.E coordinate measurement ± 0.01 , Average Brightness ± 4%

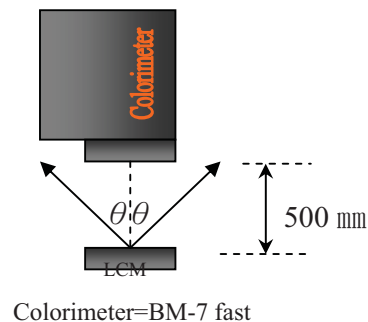
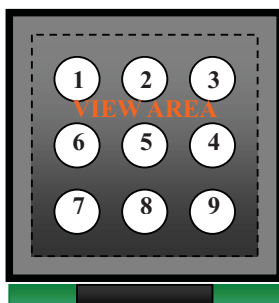

Note 1.

Optical characteristics-2

Viewing angle

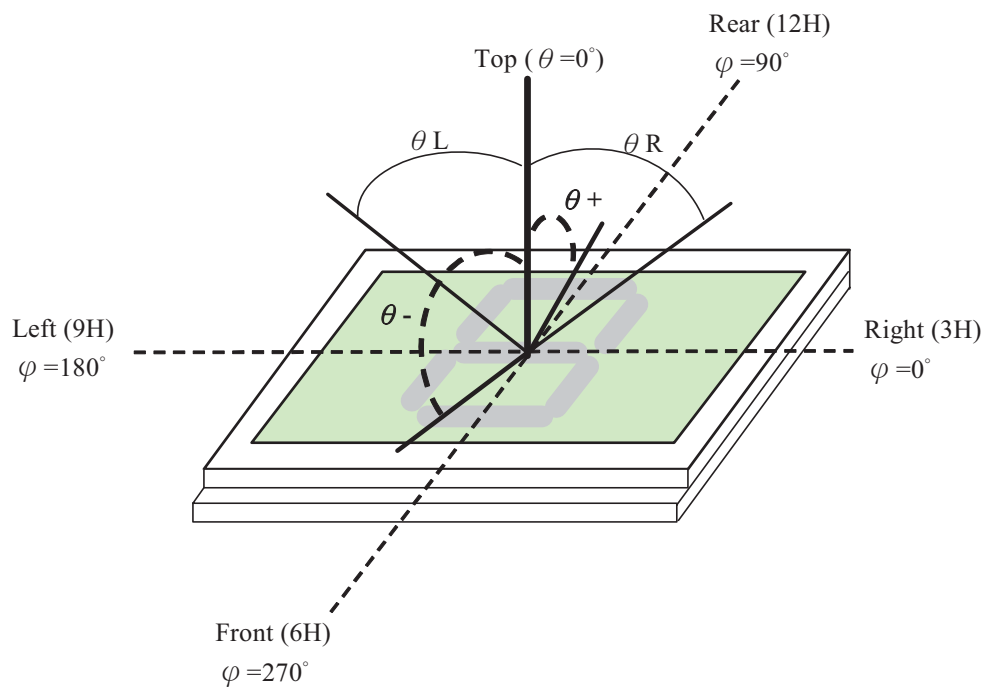

Viewing angle

Note 2.

Optical characteristics-3

Fig.2 Definition of response time

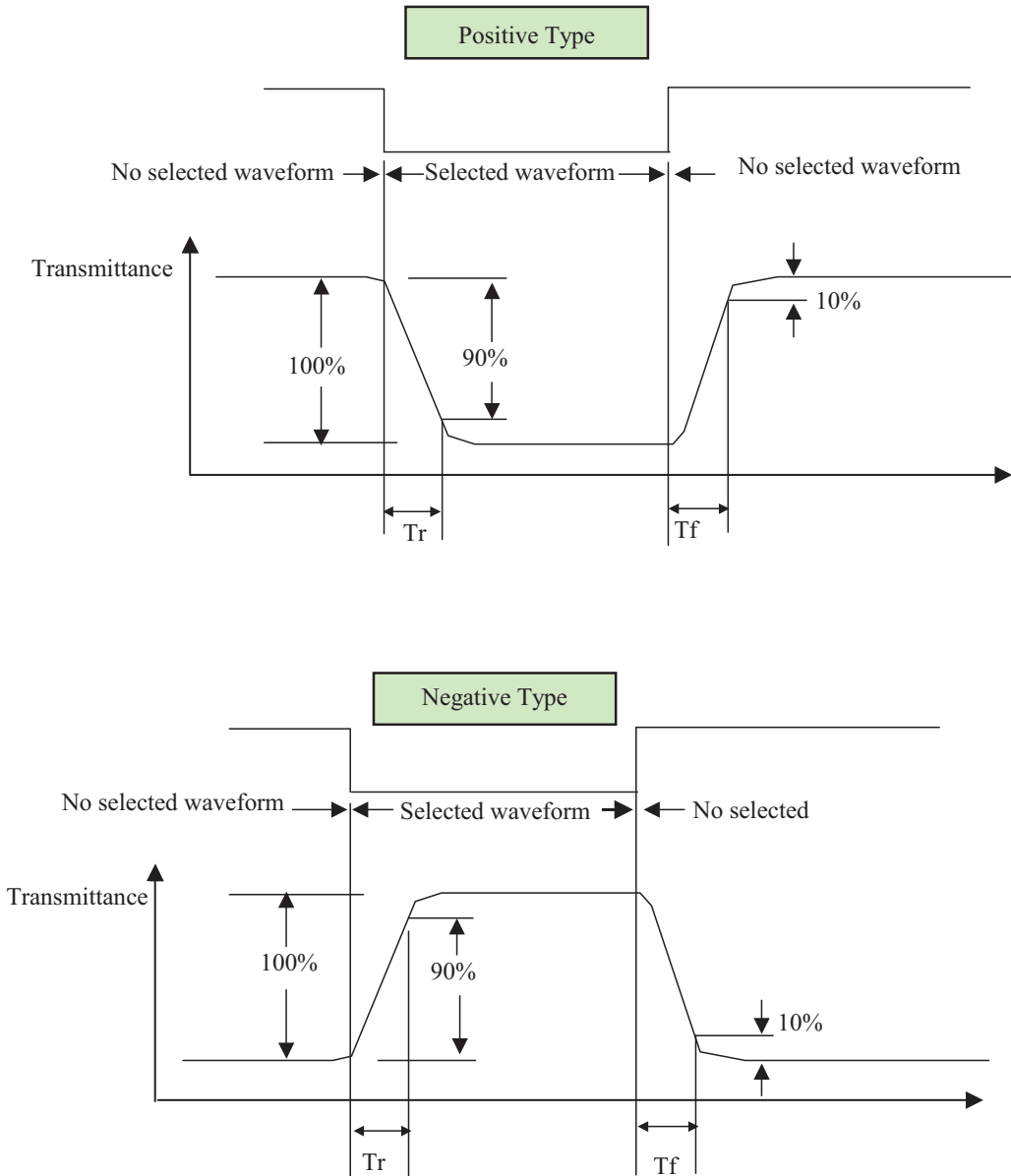

Electrical characteristics-2

※2 Drive waveform

V_{op} : Drive voltage f_F : Frame frequency

$1/B$: Bias f_D : Drive frequency

N : Duty

(1) Selected waveform

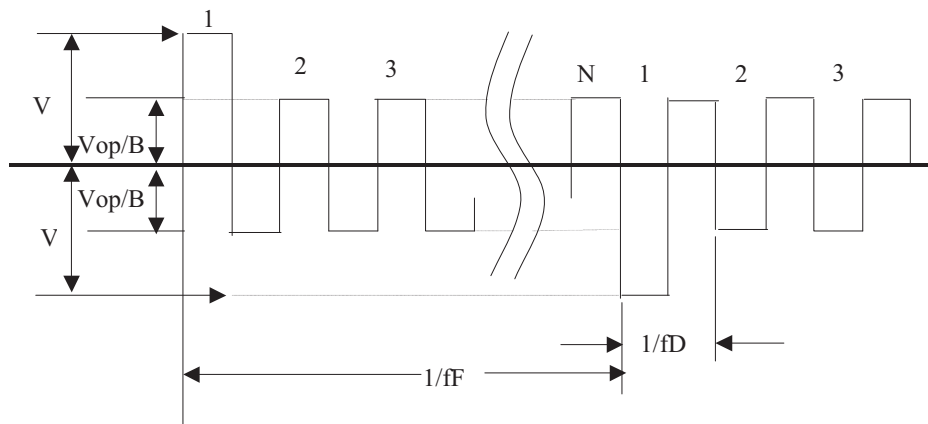

(2) Non- Selected wave form

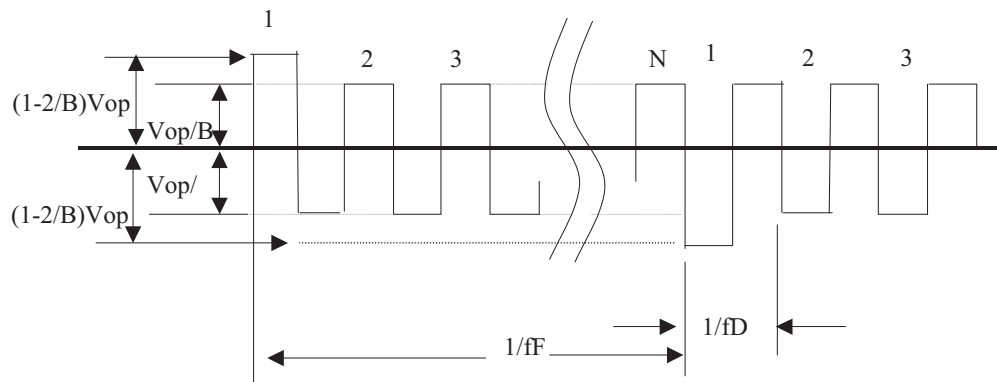

Note:

Frame frequency is defined as follows: Common side supply voltage peak - to - peak / 2 = 1 period

Note 3. : Definition of Vth

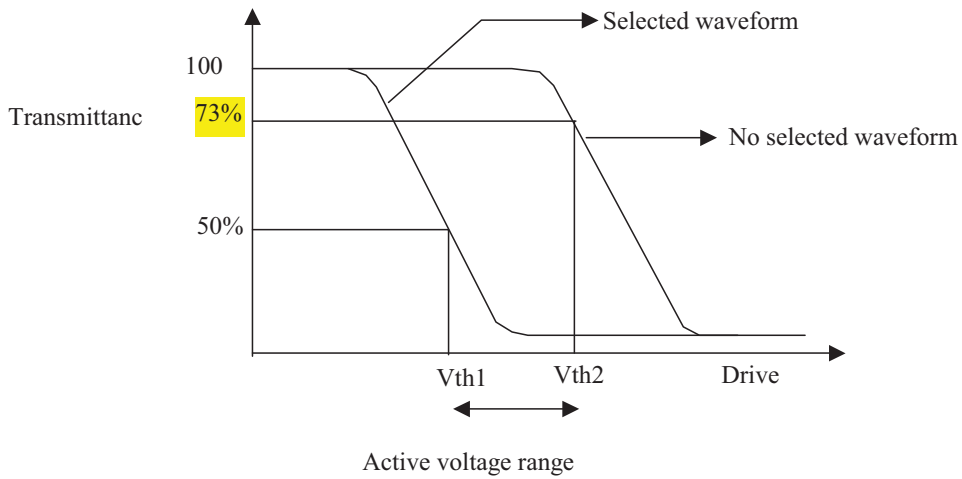

	Vth1	Vth2
View direction	10°	40°
Drive waveform	(Selected waveform)	(No selected waveform)
Transmittance	50%	73%

※1 Contrast ratio
 = (Brightness in OFF state) / (Brightness in ON state)

Outline of Electro-Optical Characteristics Measuring System

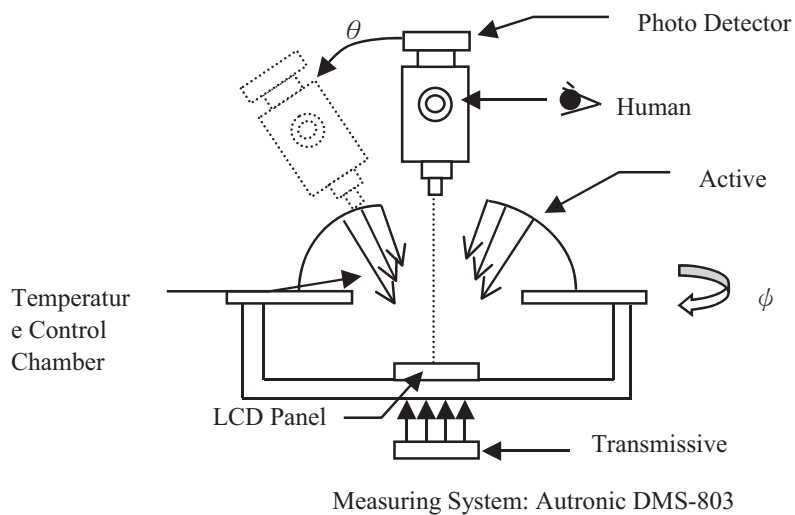

1.6 Backlight Characteristics

Maximum Ratings

Item	Symbol	Conditions	Min.	Max.	Unit
Forward Current	IF	Ta =25°C	-	40	mA
Power Dissipation	PD	Ta =25°C	-	200	mW

Electrical / Optical Characteristics

Item	Symbol	Conditions	Min.	Typ.	Max.	Unit
Forward Voltage	VF	IF= 40mA	-	-	4.0	V
Average Brightness (without LCD)	IV		700	800	-	cd/m ²
Color of CIE Coordinate (Without LCD)	X		0.26	0.31	0.34	-
	Y		0.26	0.31	0.34	
Color	White					

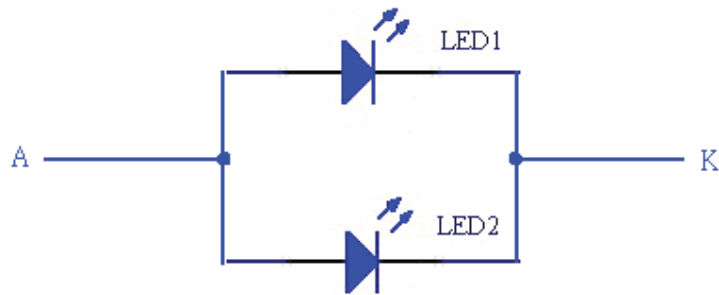

2. MODULE STRUCTURE

2.1 Counter Drawing

2.1.1 LCM Mechanical Diagram

* See Appendix

2.1.2 Block Diagram

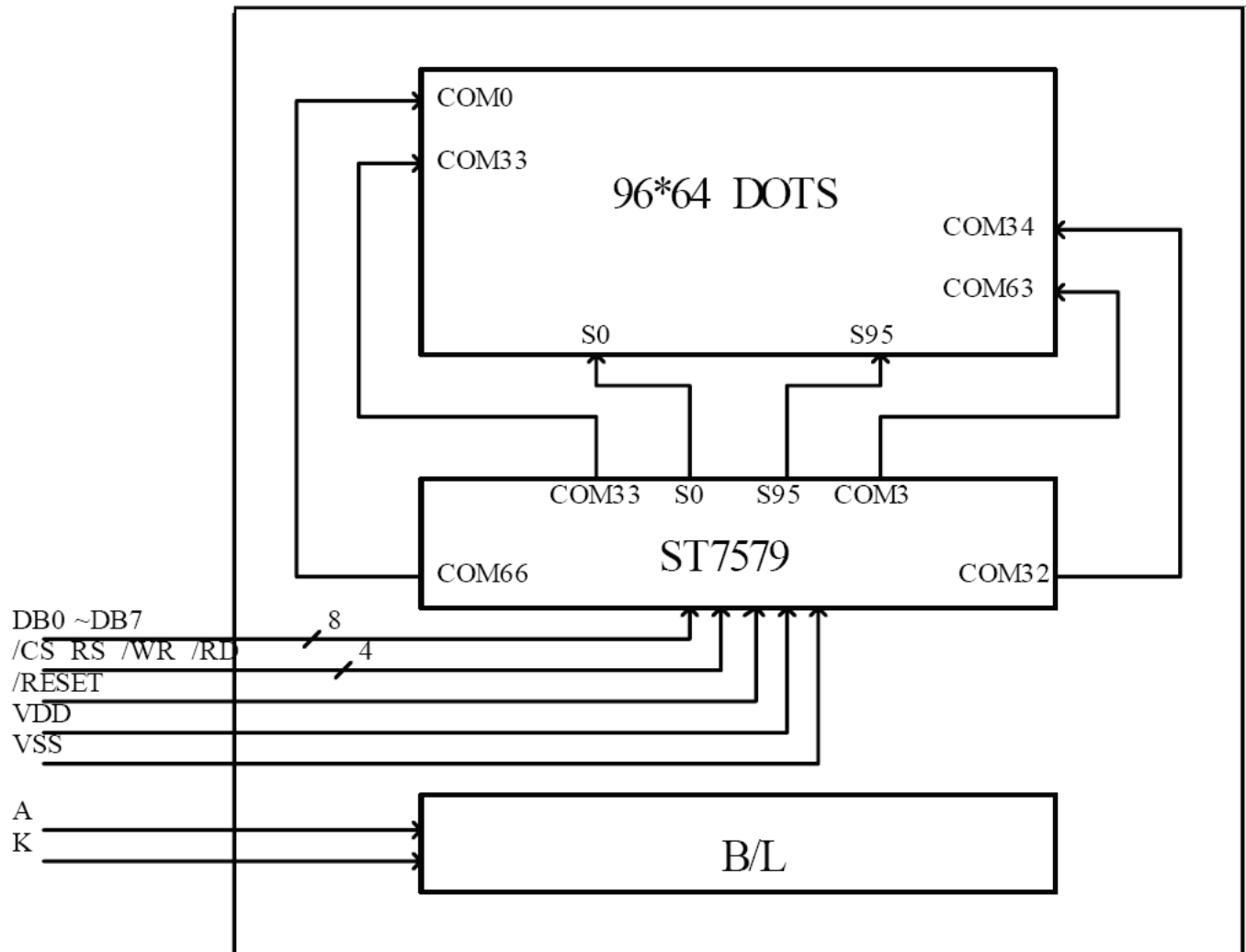

2.2 Interface Pin Description

Pin No.	Symbol	Function									
1	A	LED B/L Power supply(Anode).									
2	K	LED B/L Power supply(Cathode).									
3	VSS	System Ground.(0V)									
4	PS2	<table border="1"> <thead> <tr> <th>PS2</th> <th>PS1</th> <th>Selected Interface</th> </tr> </thead> <tbody> <tr> <td>"L"</td> <td>"L"</td> <td>4 Pin-SPI MPU interface</td> </tr> <tr> <td>"H"</td> <td>"L"</td> <td>3 Pin-SPI MPU interface</td> </tr> </tbody> </table>	PS2	PS1	Selected Interface	"L"	"L"	4 Pin-SPI MPU interface	"H"	"L"	3 Pin-SPI MPU interface
PS2	PS1	Selected Interface									
"L"	"L"	4 Pin-SPI MPU interface									
"H"	"L"	3 Pin-SPI MPU interface									
5	PS1	<table border="1"> <tbody> <tr> <td>"L"</td> <td>"H"</td> <td>8080-series parallel MPU interface</td> </tr> <tr> <td>"H"</td> <td>"H"</td> <td>6800-series parallel MPU interface</td> </tr> </tbody> </table>	"L"	"H"	8080-series parallel MPU interface	"H"	"H"	6800-series parallel MPU interface			
"L"	"H"	8080-series parallel MPU interface									
"H"	"H"	6800-series parallel MPU interface									
6	/CS	Chip select signal .Active "L".									
7	/RESET	Reset input pin. When RESB is "L", internal initialization is executed.									
8	RS	It determines whether the access is related to data or command. RS ="H" : Indicates that D[7:0] are display data. RS ="L" : Indicates that D[7:0] are control data. RS is not used in 3-line SPI interface and should fix to "H" by VDD.									
9	/WR	1.Read/Write control input pin in 6800-series parallel MPU interface. /WR="H" : read. /WR="L" : write. 2.Write enable input pin in 8080-series parallel MPU interface. Signals on D[7:0] will be latched at the rising edge of /WR signal. Note : /WR is not used in serial interfaces and should fix to "H" by VDD.									
10	/RD	1. Read/Write control input pin in 6800-series parallel MPU interface. R/W="H": When E is "H", D[7:0] are in an output status. R/W="L": Signals on D[7:0] are latched at the falling edge of E signal. 2. Read enable input pin in 8080-series parallel MPU interface. When /RD is "L", D[7:0] are in output status. Note : /RD is not used in serial interfaces and should fix to "H" by VDD.									

Pin No.	Symbol	Function
11	D0/SCLK	<p>1. When using 8-bit parallel interface: 6800 or 8080 mode 8-bit bi-directional data bus. Connect to the data bus of 8-bit microprocessor.</p> <p>When CSB is non-active (CSB="H"), D[7:0] pins are high impedance.</p> <p>2. When using serial interface: 4-LINE or 3-LINE D[7:4] : Not used and should fix to "H" by VDD. D[3:1] =SDA : Serial data input, must be connected together. D0=SCLK : Serial clock input.</p> <p>When CSB is non-active (CSB="H"), D[7:0] pins are high impedance.</p>
12	D1/SDA	
13	D2/SDA	
14	D3/SDA	
15	D4	
16	D5	
17	D6	
18	D7	
19	VSS	System Ground.(0V)
20	VDD	Power Supply.(3.3V)

2.3 Timing Characteristics

System Bus Read/Write Characteristics 1 (For the 8080 Series MPU)

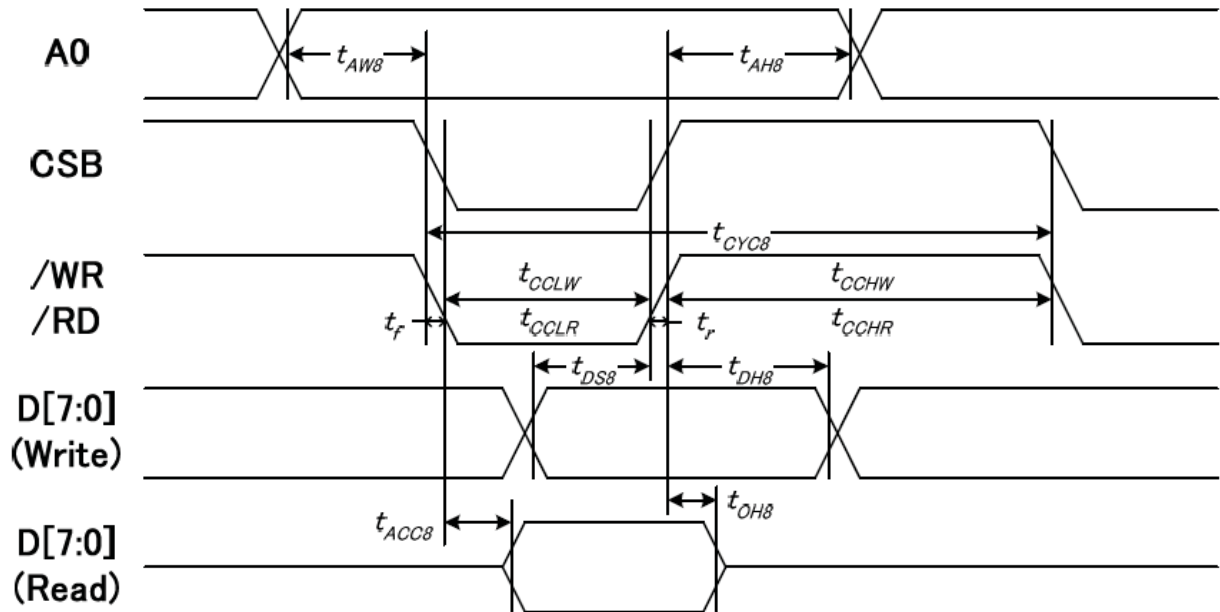

(VDD = 3.3V, Ta = -30~85°C)

Item	Signal	Symbol	Condition	Min.	Max.	Unit
Address setup time	A0	tAW8		80	—	ns
Address hold time		tAH8		10	—	
System cycle time	/WR	tCYC8		350	—	
Enable L pulse width (WRITE)		tCCLW		70	—	
Enable H pulse width (WRITE)		tCCHW		50	—	
Enable L pulse width (READ)		RD	tCCLR		120	
Enable H pulse width (READ)	tCCHR			50	—	
WRITE Data setup time	D[7:0]	tDS8		60	—	
WRITE Data hold time		tDH8		10	—	
READ access time		tACC8	CL = 16 pF	—	70	
READ Output disable time		tOH8	CL = 16 pF	10	50	

System Bus Read/Write Characteristics 1 (For the 6800 Series MPU)

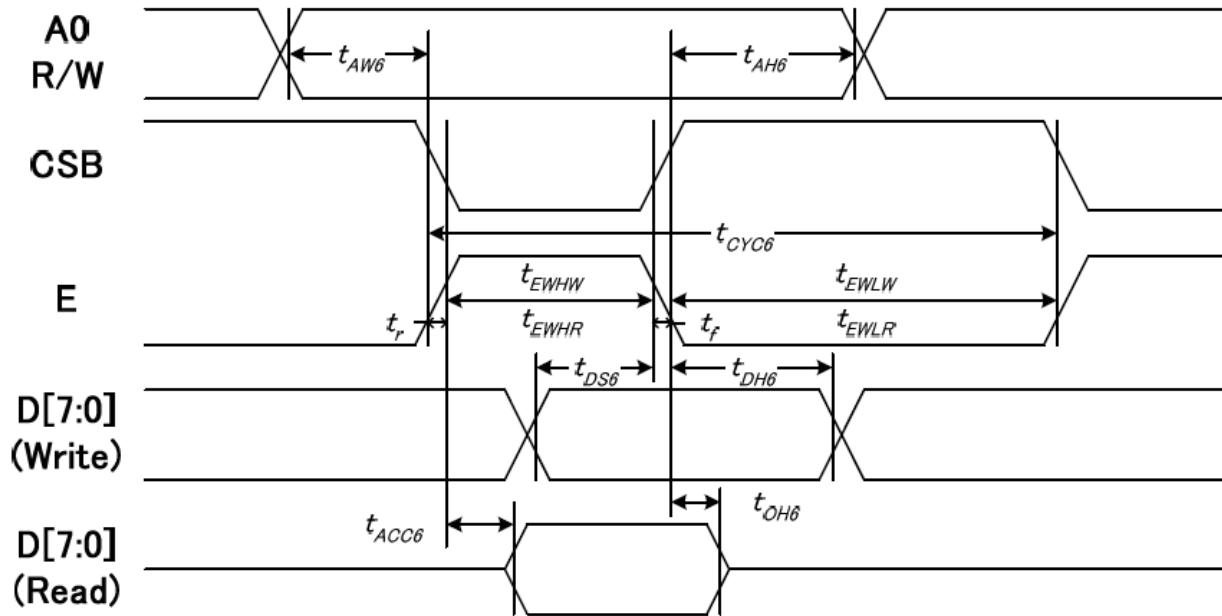

(VDD = 3.3V , Ta = -30~85°C)

Item	Signal	Symbol	Condition	Min.	Max.	Unit
Address setup time	A0	tAW6		80	—	ns
Address hold time		tAH6		10	—	
System cycle time	E	tCYC6		240	—	
Enable L pulse width (WRITE)		tEHLW		70	—	
Enable H pulse width (WRITE)		tEHWLW		50	—	
Enable L pulse width (READ)		tEHLR		70	—	
Enable H pulse width (READ)	tEHWHR		130	—		
Write data setup time	D[7:0]	tDS6		60	—	
Write data hold time		tDH6		10	—	
Read data access time		tACC6	CL = 16 pF	—	70	
Read data output disable time		tOH6	CL = 16 pF	10	50	

SERIAL INTERFACE (4-Line Interface)

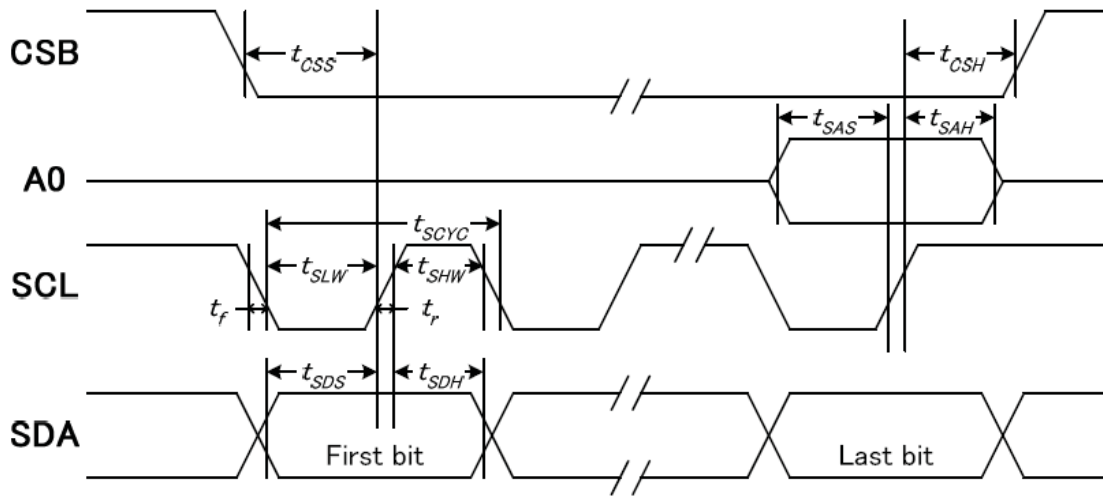

(VDD = 3.3V, Ta = -30~85°C)

Item	Signal	Symbol	Condition	Min.	Max.	Unit
Serial clock period	SCLK	tSCYC		120	—	ns
SCLK "H" pulse width		tSHW		60	—	
SCLK "L" pulse width		tSLW		60	—	
Address setup time	A0	tSAS		20	—	
Address hold time		tSAH		90	—	
Data setup time	SDA	tSDS		20	—	
Data hold time		tSDH		10	—	
CSB-SCLK time	CSB	tCSS		20	—	
CSB-SCLK time		tCSH		120	—	

SERIAL INTERFACE (3-Line Interface)

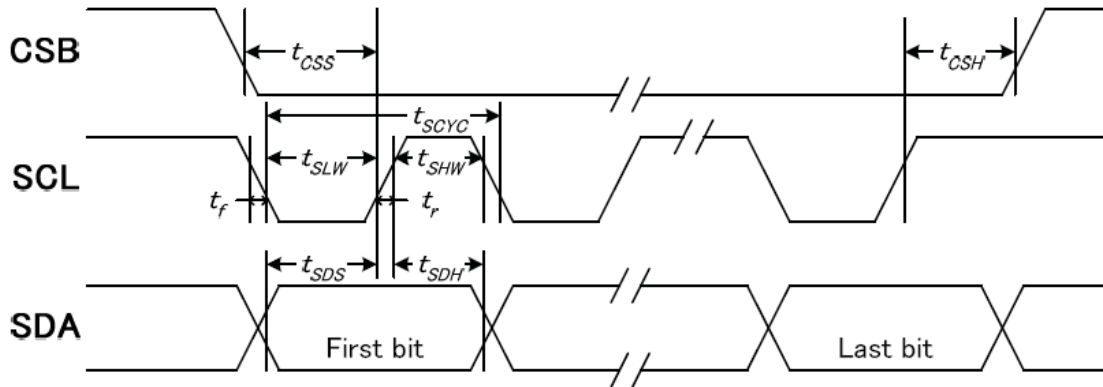

(VDD = 3.3V, Ta = -30~85°C)

Item	Signal	Symbol	Condition	Min.	Max.	Unit
Serial clock period	SCLK	tSCYC		120	—	ns
SCLK "H" pulse width		tSHW		60	—	
SCLK "L" pulse width		tSLW		60	—	
Data setup time	SDA	tSDS		20	—	
Data hold time		tSDH		10	—	
CSB-SCLK time	CSB	tCSS		20	—	
CSB-SCLK time		tCSH		130	—	

RESET TIMING

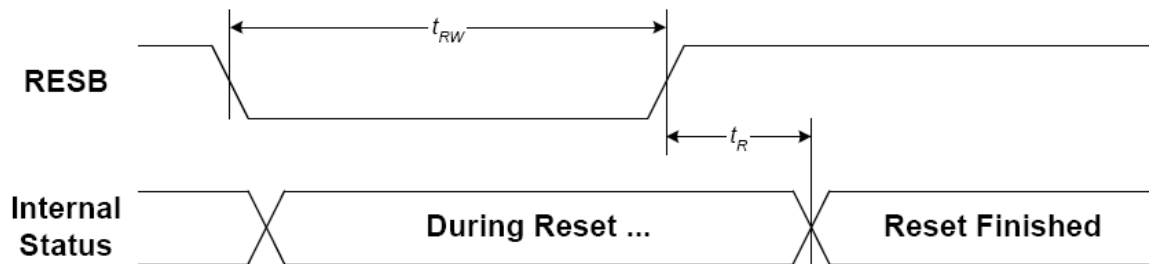

(VDD = 3.3V, Ta = -30~85°C)

Item	Symbol	Condition	Min.	Max.	Unit
Reset time	tR		—	1.5	us
Reset "L" pulse width	tRW		1.5	—	

2.4 Display Command

INSTRUCTION	A0	R/W (RWR)	COMMAND BYTE								DESCRIPTION	
			D7	D6	D5	D4	D3	D2	D1	D0		
H[1:0] Independent Instruction												
NOP	0	0	0	0	0	0	0	0	0	0	0	No operation
Reserved	0	0	0	0	0	0	0	0	0	0	1	Do not use
Function Set	0	0	0	0	1	MX	MY	PD	H1	H0		Power down; entry mode; Select instruction table
Read Status	0	1	PD	0	0	D	E	MX	MY	DO		Read status byte
Read Data	1	1	D7	D6	D5	D4	D3	D2	D1	D0		Read data to RAM
Write Data	1	0	D7	D6	D5	D4	D3	D2	D1	D0		Write data to RAM
H[1:0] = (0,0)												
Reserved	0	0	0	0	0	0	0	0	1	X		Do not use
Set V0 Range	0	0	0	0	0	0	0	1	0	PRS		V0 range L/H select
END	0	0	0	0	0	0	0	1	1	0		Release read/modify/write
Read-modify-Write	0	0	0	0	0	0	0	1	1	1		RAM address at R:+0 , W:+1
Display Control	0	0	0	0	0	0	1	D	0	E		Sets display configuration
Reserved	0	0	0	0	0	1	0	0	X	X		Do not use
Set Y Address of RAM	0	0	0	1	0	0	Y3	Y2	Y1	Y0		Sets Y address of RAM 0≤Y≤9
Set X Address of RAM	0	0	1	X6	X5	X4	X3	X2	X1	X0		Sets X address of RAM 0≤X≤101
H[1:0] = (0,1)												
Reserved	0	0	0	0	0	0	0	0	1	X		Do not use
Display Configuration	0	0	0	0	0	0	1	DO	X	X		Top/bottom row mode set data order
Bias System	0	0	0	0	0	1	0	BS2	BS1	BS0		Set bias system (BSx)
Set Start Line (high)	0	0	0	0	0	0	0	1	0	S6		Specify the initial display line S6
Set Start Line (low)	0	0	0	1	S5	S4	S3	S2	S1	S0		Specify the initial display line to realize vertical scrolling
Set V0	0	0	1	V _{OP6}	V _{OP5}	V _{OP4}	V _{OP3}	V _{OP2}	V _{OP1}	V _{OP0}		Set V _{OP} parameter to register
H[1:0] = (1,0)												
Reserved	0	0	0	0	0	0	0	0	1	X		Do not use
Partial Screen Mode	0	0	0	0	0	0	0	1	0	PS		Partial screen enable
Partial Screen Size	0	0	0	0	0	0	1	0	0	WS		Set partial screen size
Display Part	0	0	0	0	0	1	0	DP2	DP1	DP0		Set display part for partial screen mode
H[1:0] = (1,1)												
Reserved	0	0	0	0	0	0	0	0	0	X		Do not use
RESET	0	0	0	0	0	0	0	0	1	1		Software reset
Frame Control	0	0	0	0	0	0	1	FR2	FR1	FR0		Frame rate control
N-Line Inversion	0	0	0	1	0	NL4	NL3	NL2	NL1	NL0		Sets N-Line inversion
Booster Efficiency & Booster Stage	0	0	1	0	0	1	BE1	BE0	PC1	PC0		Booster Efficiency Set
Reserved	0	0	1	X	X	X	X	X	X	X		Do not use

3. QUALITY ASSURANCE SYSTEM

3.1 Quality Assurance Flow Chart

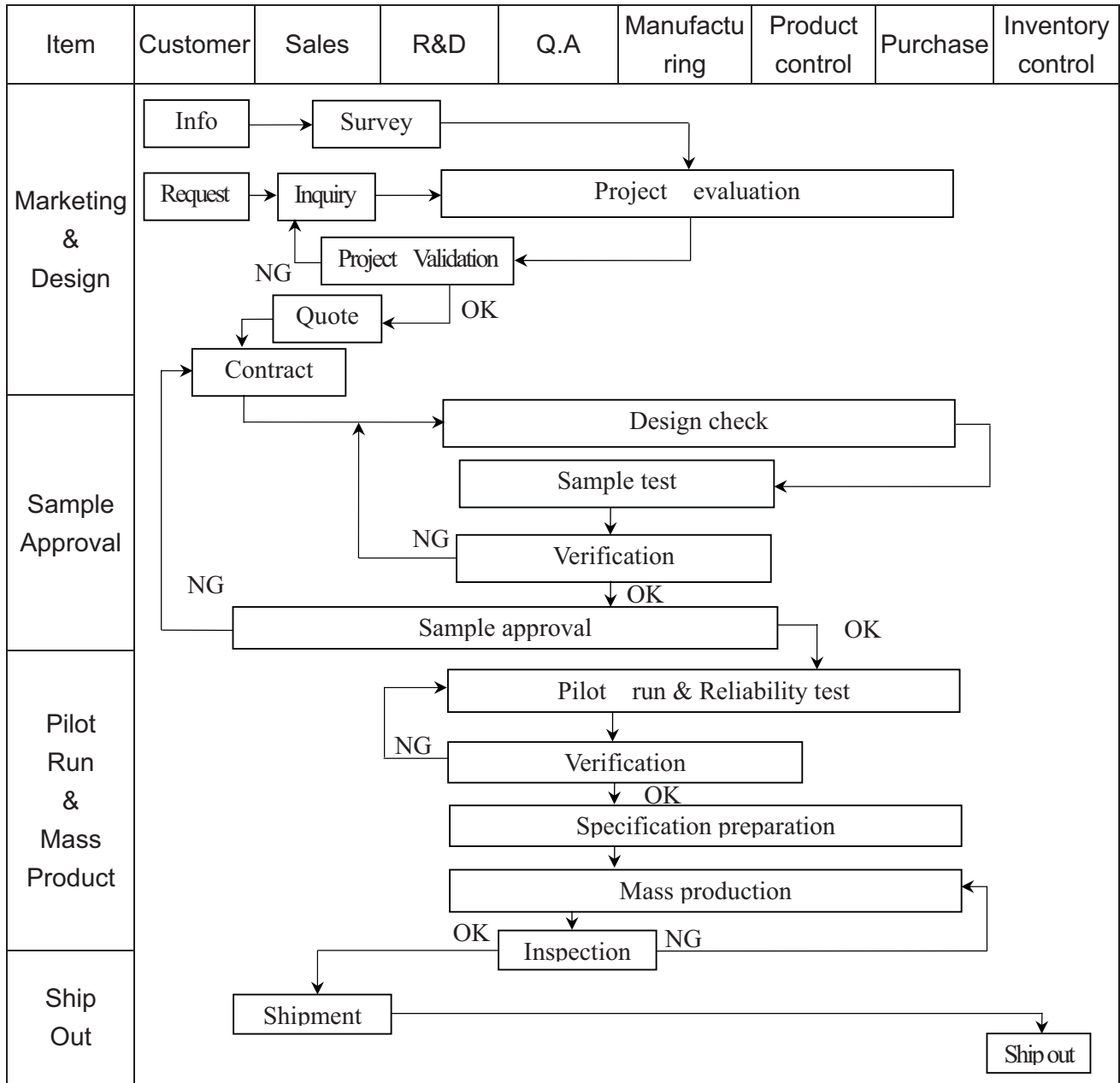

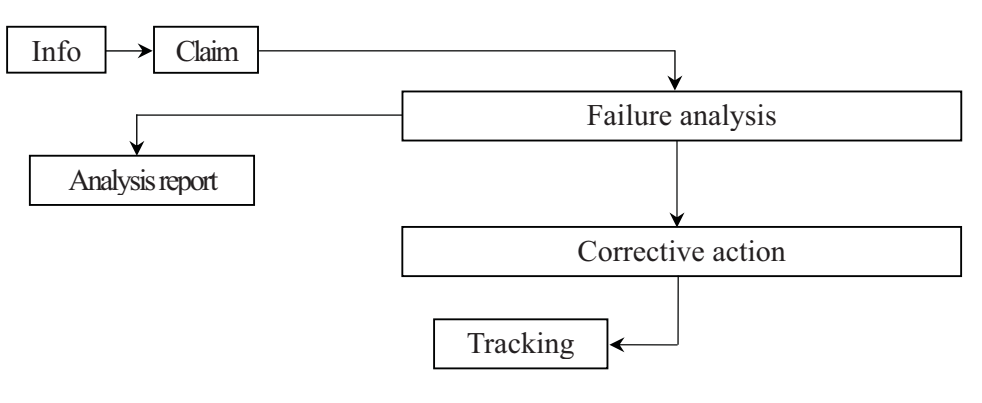
Item	Customer	Sales	R&D	Q.A	Manufacturing	Product control	Purchase	Inventory control
Sales Service	 <pre> graph TD Info[Info] --> Claim[Claim] Claim --> Failure[Failure analysis] Claim --> Report[Analysis report] Failure --> Action[Corrective action] Action --> Tracking[Tracking] </pre>							
Q.A Activity	1. ISO 9001 Maintenance Activities 3. Equipment calibration 5. Standardization Management				2. Process improvement proposal 4. Education And Training Activities			

3.2 Inspection Specification

◆ **Scope** : The document shall be applied to LCD Module for Monotype and Color STN(Ver. B01).

◆ **Inspection Standard** : MIL-STD-105E Table Normal Inspection Single Sampling Level II .

◆ **Equipment** : Gauge 、 MIL-STD 、 Powertip Tester 、 Sample

◆ **Defect Level** : Major Defect AQL : 0.4 ; Minor Defect : AQL : 1.5 .

◆ **OUT Going Defect Level** : Sampling .

◆ **Manner of appearance test** :

(1). The test be under 20W×2 fluorescent light ' and distance of view must be at 30 cm.

(2). Standard of inspection : (Unit : mm)

(3). The test direction is base on about around 45° of vertical line. (Fig. 1)

(4). Definition of area . (Fig. 2)

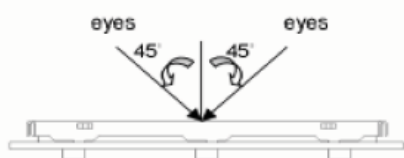

Fig.1

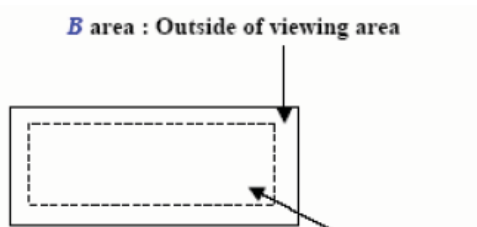
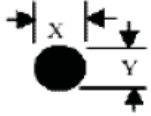
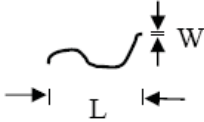
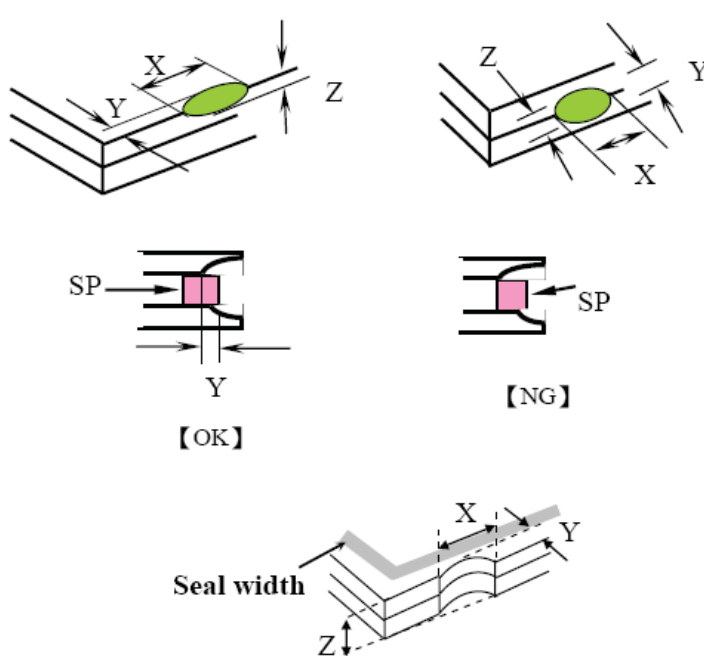

Fig. 2 A area : viewing area

◆ **Specification:**

NO	Item	Criterion	Level
01	Product condition	1. 1 The part number is inconsistent with work order of Production.	Major
		1. 2 Mixed production types.	Major
		1. 3 Assembled in inverse direction.	Major
02	Quantity	2. 1 The quantity is inconsistent with work order of production.	Major
03	Outline dimension	3. 1 Product dimension and structure must conform to Structure diagram.	Major
04	Electrical Testing	4. 1 Missing line character and icon.	Major
		4. 2 No function or no display.	Major
		4. 3 Output data is error.	Major
		4. 4 LCD viewing angle defect.	Major
		4. 5 Current consumption exceeds product specifications.	Major

NO	Item	Criterion	Level																																				
05	<p>Black or white dot、scratch、contamination</p> <p>Round type</p>  <p>$\Phi = (x+y)/2$</p> <p>Line type</p> 	<p>5. 1 Round type:</p> <p>5. 1. 1 display only :</p> <ul style="list-style-type: none"> • White and black spots on display ≤ 0.30 mm , no more than 4 white or black spots present. • Densely spaced : NO more than two spots or lines within 3 mm. <p>5. 1. 2 Non-display :</p> <table border="1" data-bbox="521 623 1305 942"> <thead> <tr> <th rowspan="2">Dimension (diameter : Φ)</th> <th colspan="2">Acceptance (Q'ty)</th> </tr> <tr> <th>A area</th> <th>B area</th> </tr> </thead> <tbody> <tr> <td>$\Phi \leq 0.10$</td> <td colspan="2">Accept no dense</td> </tr> <tr> <td>$0.10 < \Phi \leq 0.20$</td> <td>3</td> <td rowspan="3">Ignore</td> </tr> <tr> <td>$0.20 < \Phi \leq 0.30$</td> <td>2</td> </tr> <tr> <td>Total quantity</td> <td>4</td> </tr> </tbody> </table> <p>5. 1. 3 Line type:</p> <table border="1" data-bbox="477 1014 1352 1329"> <thead> <tr> <th colspan="2">Dimension</th> <th colspan="2">Acceptance (Q'ty)</th> </tr> <tr> <th>Length (L)</th> <th>Width (W)</th> <th>A area</th> <th>B area</th> </tr> </thead> <tbody> <tr> <td>---</td> <td>$W \leq 0.03$</td> <td>Accept no dense</td> <td rowspan="3">Ignore</td> </tr> <tr> <td>$L \leq 3.0$</td> <td>$0.03 < W \leq 0.05$</td> <td rowspan="2">4</td> </tr> <tr> <td>$L \leq 2.5$</td> <td>$0.05 < W \leq 0.075$</td> </tr> <tr> <td>---</td> <td>$W > 0.075$</td> <td colspan="2">As round type</td> </tr> </tbody> </table>	Dimension (diameter : Φ)	Acceptance (Q'ty)		A area	B area	$\Phi \leq 0.10$	Accept no dense		$0.10 < \Phi \leq 0.20$	3	Ignore	$0.20 < \Phi \leq 0.30$	2	Total quantity	4	Dimension		Acceptance (Q'ty)		Length (L)	Width (W)	A area	B area	---	$W \leq 0.03$	Accept no dense	Ignore	$L \leq 3.0$	$0.03 < W \leq 0.05$	4	$L \leq 2.5$	$0.05 < W \leq 0.075$	---	$W > 0.075$	As round type		Minor
Dimension (diameter : Φ)	Acceptance (Q'ty)																																						
	A area	B area																																					
$\Phi \leq 0.10$	Accept no dense																																						
$0.10 < \Phi \leq 0.20$	3	Ignore																																					
$0.20 < \Phi \leq 0.30$	2																																						
Total quantity	4																																						
Dimension		Acceptance (Q'ty)																																					
Length (L)	Width (W)	A area	B area																																				
---	$W \leq 0.03$	Accept no dense	Ignore																																				
$L \leq 3.0$	$0.03 < W \leq 0.05$	4																																					
$L \leq 2.5$	$0.05 < W \leq 0.075$																																						
---	$W > 0.075$	As round type																																					
06	Polarizer Bubble	<table border="1" data-bbox="480 1383 1349 1745"> <thead> <tr> <th rowspan="2">Dimension (diameter : Φ)</th> <th colspan="2">Acceptance (Q'ty)</th> </tr> <tr> <th>A area</th> <th>B area</th> </tr> </thead> <tbody> <tr> <td>$\Phi \leq 0.20$</td> <td colspan="2">Accept no dense</td> </tr> <tr> <td>$0.20 < \Phi \leq 0.50$</td> <td>3</td> <td rowspan="3">Ignore</td> </tr> <tr> <td>$0.50 < \Phi \leq 1.00$</td> <td>2</td> </tr> <tr> <td>$\Phi > 1.00$</td> <td>0</td> </tr> <tr> <td>Total quantity</td> <td>4</td> <td></td> </tr> </tbody> </table>	Dimension (diameter : Φ)	Acceptance (Q'ty)		A area	B area	$\Phi \leq 0.20$	Accept no dense		$0.20 < \Phi \leq 0.50$	3	Ignore	$0.50 < \Phi \leq 1.00$	2	$\Phi > 1.00$	0	Total quantity	4		Minor																		
Dimension (diameter : Φ)	Acceptance (Q'ty)																																						
	A area	B area																																					
$\Phi \leq 0.20$	Accept no dense																																						
$0.20 < \Phi \leq 0.50$	3	Ignore																																					
$0.50 < \Phi \leq 1.00$	2																																						
$\Phi > 1.00$	0																																						
Total quantity	4																																						

NO	Item	Criterion	Level									
07	The crack of glass	<p>Symbols :</p> <p>X : The length of crack Y : The width of crack. Z : The thickness of crack W : terminal length t : The thickness of glass a : LCD side length</p> <hr/> <p>7.1 General glass chip :</p> <p>7.1.1 Chip on panel surface and crack between panels:</p>  <table border="1" data-bbox="535 1407 1282 1680"> <thead> <tr> <th>X</th> <th>Y</th> <th>Z</th> </tr> </thead> <tbody> <tr> <td>$\leq a$</td> <td>Crack can't enter viewing area</td> <td>$\leq 1/2 t$</td> </tr> <tr> <td>$\leq a$</td> <td>Crack can't exceed the half of SP width.</td> <td>$1/2 t < Z \leq 2 t$</td> </tr> </tbody> </table>	X	Y	Z	$\leq a$	Crack can't enter viewing area	$\leq 1/2 t$	$\leq a$	Crack can't exceed the half of SP width.	$1/2 t < Z \leq 2 t$	Minor
X	Y	Z										
$\leq a$	Crack can't enter viewing area	$\leq 1/2 t$										
$\leq a$	Crack can't exceed the half of SP width.	$1/2 t < Z \leq 2 t$										

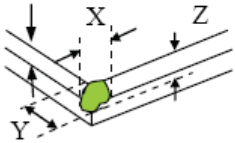
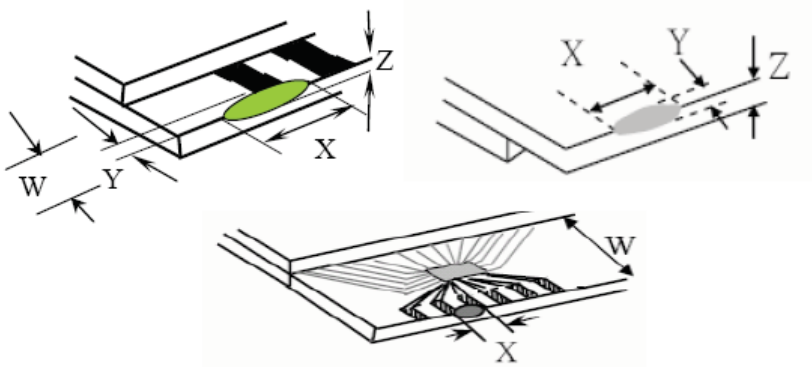
NO	Item	Criterion	Level									
07	The crack of glass	<p>Symbols :</p> <p>X : The length of crack Y : The width of crack. Z : The thickness of crack W : terminal length t : The thickness of glass a : LCD side length</p> <hr/> <p>7.1.2 Corner crack :</p>  <table border="1" data-bbox="535 762 1294 1035"> <thead> <tr> <th>X</th> <th>Y</th> <th>Z</th> </tr> </thead> <tbody> <tr> <td>$\leq 1/5 a$</td> <td>Crack can't enter viewing area</td> <td>$Z \leq 1/2 t$</td> </tr> <tr> <td>$\leq 1/5 a$</td> <td>Crack can't exceed the half of SP width.</td> <td>$1/2 t < Z \leq 2 t$</td> </tr> </tbody> </table>	X	Y	Z	$\leq 1/5 a$	Crack can't enter viewing area	$Z \leq 1/2 t$	$\leq 1/5 a$	Crack can't exceed the half of SP width.	$1/2 t < Z \leq 2 t$	Minor
		X	Y	Z								
$\leq 1/5 a$	Crack can't enter viewing area	$Z \leq 1/2 t$										
$\leq 1/5 a$	Crack can't exceed the half of SP width.	$1/2 t < Z \leq 2 t$										
<p>7.2 Protrusion over terminal :</p> <p>7.2.1 Chip on electrode pad :</p>  <table border="1" data-bbox="505 1581 1235 1745"> <thead> <tr> <th></th> <th>X</th> <th>Y</th> <th>Z</th> </tr> </thead> <tbody> <tr> <td>Front</td> <td>$\leq a$</td> <td>$\leq 1/2 W$</td> <td>$\leq t$</td> </tr> <tr> <td>Back</td> <td colspan="3">Neglect</td> </tr> </tbody> </table>		X	Y	Z	Front	$\leq a$	$\leq 1/2 W$	$\leq t$	Back	Neglect		
	X	Y	Z									
Front	$\leq a$	$\leq 1/2 W$	$\leq t$									
Back	Neglect											

◆ Specification For Monotype and Color STN :

(Ver. B01)

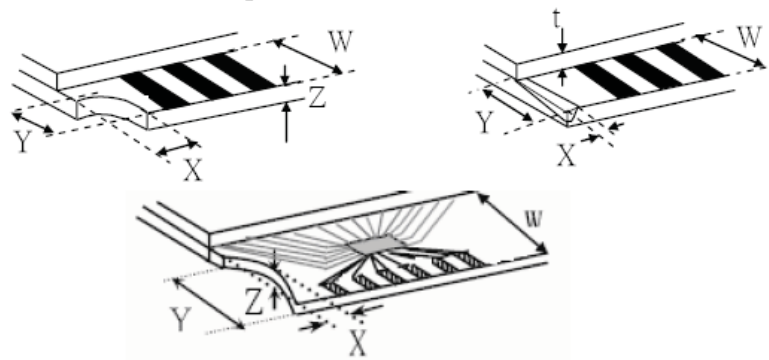
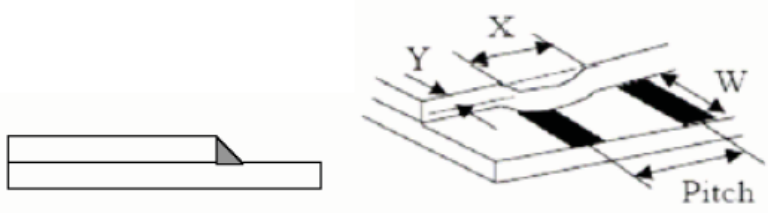
NO	Item	Criterion	Level									
07	The crack of glass	<p>Symbols :</p> <p>X : The length of crack Y : The width of crack. Z : The thickness of crack W : terminal length t : The thickness of glass a : LCD side length</p>	Minor									
		<p>7.2.2 Non-conductive portion :</p>  <table border="1" data-bbox="609 976 1193 1123"> <thead> <tr> <th>X</th> <th>Y</th> <th>Z</th> </tr> </thead> <tbody> <tr> <td>$\leq 1/3 a$</td> <td>$\leq W$</td> <td>$\leq t$</td> </tr> </tbody> </table> <p>⊙ If the chipped area touches the ITO terminal, over 2/3 of the ITO must remain and be inspected according to electrode terminal specifications.</p> <p>7.2.3 Glass remain :</p>  <table border="1" data-bbox="535 1617 1177 1753"> <thead> <tr> <th>X</th> <th>Y</th> <th>Z</th> </tr> </thead> <tbody> <tr> <td>$\leq a$</td> <td>$\leq 1/3 W$</td> <td>$\leq t$</td> </tr> </tbody> </table>		X	Y	Z	$\leq 1/3 a$	$\leq W$	$\leq t$	X	Y	Z
X	Y	Z										
$\leq 1/3 a$	$\leq W$	$\leq t$										
X	Y	Z										
$\leq a$	$\leq 1/3 W$	$\leq t$										

◆ Specification For Monotype and Color STN :

(Ver. B01)

NO	Item	Criterion	Level
08	Backlight elements	8. 1 Backlight can't work normally.	Major
		8. 2 Backlight doesn't light or color is wrong.	Major
		8. 3 Illumination source flickers when lit.	Major
09	General appearance	9. 1 Pin type must match type in specification sheet.	Major
		9. 2 No short circuits in components on PCB or FPC.	Major
		9. 3 Product packaging must the same as specified on packaging specification sheet.	Minor
		9. 4 The folding and peeled off in polarizer are not acceptable.	Minor
		9. 5 The PCB or FPC between B/L assembled distance (PCB or FPC) is ≤ 1.5 mm.	Minor

4. RELIABILITY TEST

4.1 Reliability Test Condition

(Ver.B01)

NO.	TEST ITEM	TEST CONDITION											
1	High Temperature Storage Test	Keep in $+80 \pm 2^{\circ}\text{C}$ 96 hrs Surrounding temperature, then storage at normal condition 4hrs.											
2	Low Temperature Storage Test	Keep in $-30 \pm 2^{\circ}\text{C}$ 96 hrs Surrounding temperature, then storage at normal condition 4hrs.											
3	High Temperature / High Humidity Storage Test	Keep in $+60^{\circ}\text{C}$ / 90% R.H duration for 96 hrs Surrounding temperature, then storage at normal condition 4hrs. (Excluding the polarizer)											
4	Temperature Cycling Storage Test	$ \begin{array}{ccccccc} & -30^{\circ}\text{C} & \rightarrow & +25^{\circ}\text{C} & \rightarrow & +80^{\circ}\text{C} & \rightarrow & +25^{\circ}\text{C} \\ & (30\text{mins}) & & (5\text{mins}) & & (30\text{mins}) & & (5\text{mins}) \\ & \longleftarrow & & & & & & \longrightarrow \\ & & & & & & & 10 \text{ Cycle} \end{array} $ Surrounding temperature, then storage at normal condition 4hrs.											
5	ESD Test	Air Discharge: Apply 2 KV with 5 times Discharge for each polarity +/-	Contact Discharge: Apply 250 V with 5 times discharge for each polarity +/-										
		1. Temperature ambience : $15^{\circ}\text{C} \sim 35^{\circ}\text{C}$ 2. Humidity relative : 30%~60% 3. Energy Storage Capacitance(Cs+Cd) : $150\text{pF} \pm 10\%$ 4. Discharge Resistance(Rd) : $330\Omega \pm 10\%$ 5. Discharge, mode of operation : Single Discharge (time between successive discharges at least 1 sec) (Tolerance if the output voltage indication : $\pm 5\%$)											
6	Vibration Test (Packaged)	1. Sine wave 10~55 Hz frequency (1 min/sweep) 2. The amplitude of vibration : 1.5 mm 3. Each direction (X、Y、Z) duration for 2 Hrs											
7	Drop Test (Packaged)	<table border="1"> <thead> <tr> <th>Packing Weight (Kg)</th> <th>Drop Height (cm)</th> </tr> </thead> <tbody> <tr> <td>0 ~ 45.4</td> <td>122</td> </tr> <tr> <td>45.4 ~ 90.8</td> <td>76</td> </tr> <tr> <td>90.8 ~ 454</td> <td>61</td> </tr> <tr> <td>Over 454</td> <td>46</td> </tr> </tbody> </table>		Packing Weight (Kg)	Drop Height (cm)	0 ~ 45.4	122	45.4 ~ 90.8	76	90.8 ~ 454	61	Over 454	46
		Packing Weight (Kg)	Drop Height (cm)										
		0 ~ 45.4	122										
		45.4 ~ 90.8	76										
		90.8 ~ 454	61										
Over 454	46												
Drop Direction : ※1 corner / 3 edges / 6 sides each 1time													

5. PRECAUTION RELATING PRODUCT HANDLING

5.1 SAFETY

- 5.1.1 If the LCD panel breaks , be careful not to get the liquid crystal to touch your skin.
- 5.1.2 If the liquid crystal touches your skin or clothes , please wash it off immediately by using soap and water.

5.2 HANDLING

- 5.2.1 Avoid any strong mechanical shock which can break the glass.
- 5.2.2 Avoid static electricity which can damage the CMOS LSI—When working with the module , be sure to ground your body and any electrical equipment you may be using.
- 5.2.3 Do not remove the panel or frame from the module.
- 5.2.4 The polarizing plate of the display is very fragile. So , please handle it very carefully ,do not touch , push or rub the exposed polarizing with anything harder than an HB pencil lead (glass , tweezers , etc.)
- 5.2.5 Do not wipe the polarizing plate with a dry cloth , as it may easily scratch the surface of plate.
- 5.2.6 Do not touch the display area with bare hands , this will stain the display area.
- 5.2.7 Do not use ketonics solvent & aromatic solvent. Use with a soft cloth soaked with a cleaning naphtha solvent.
- 5.2.8 To control temperature and time of soldering is $320\pm 10^{\circ}\text{C}$ and 3-5 sec.
- 5.2.9 To avoid liquid (include organic solvent) stained on LCM .

5.3 STORAGE

- 5.3.1 Store the panel or module in a dark place where the temperature is $25^{\circ}\text{C} \pm 5^{\circ}\text{C}$ and the humidity is below 65% RH.
- 5.3.2 Do not place the module near organics solvents or corrosive gases.
- 5.3.3 Do not crush , shake , or jolt the module.

5.4 TERMS OF WARRANTY

- 5.4.1 Applicable warrant period
The period is within thirteen months since the date of shipping out under normal using and storage conditions.
 - 5.4.2 Unaccepted responsibility
This product has been manufactured to your company's specification as a part for use in your company's general electronic products. It is guaranteed to perform according to delivery specifications. For any other use apart from general electronic equipment , we cannot take responsibility if the product is used in nuclear power control equipment , aerospace equipment , fire and security systems or any other applications in which there is a direct risk to human life and where extremely high levels of reliability are required.
-

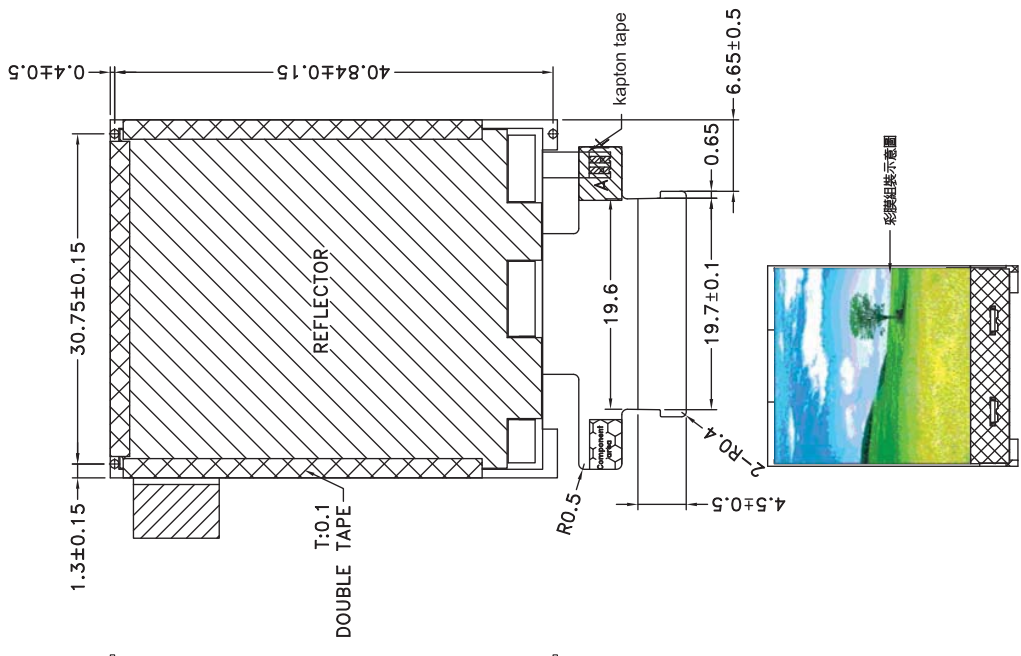
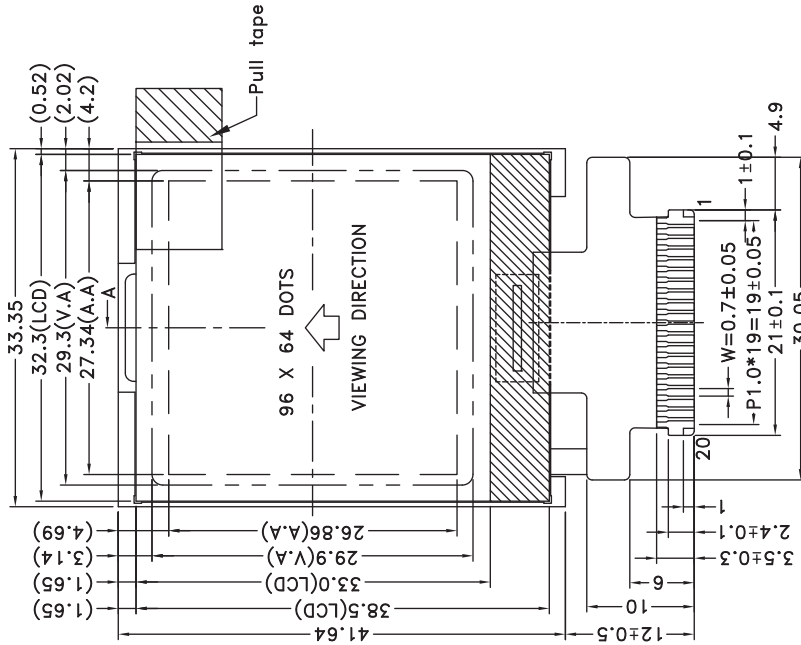

NO.	NAME
1	A
2	K
3	VSS
4	PS2
5	PS1
6	/CS
7	/RESET
8	RS
9	/WR
10	/RD
11	DO/SCLK
12	D1/SDA
13	D2/SDA
14	D3/SDA
15	D4
16	D5
17	D6
18	D7
19	VSS
20	VDD

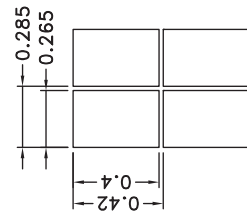

- NOTES:
- LCD TYPE: FSTN
 - LCD DISPLAY: POSITIVE/TRANSMISSIVE
 - VIEW DIRECTION: 6 O'CLOCK
 - Top: -20~70°C Tst: -30~80°C
 - The tolerance unless classified ±0.2mm
 - IC NO.: ST7579
 - B=0.8x19=15.2±0.1, W=0.5±0.05
 - Color film pattern will be provided by customer.

REV	REV BY	REVISER	DATE
001	NEW DRAWING	Air	2010/05/31
002			
003			
004			
005			
006			
007			

Design	Air	(3)	Surface
Check	Zhou	MM	Material
Approve	Ryan	Scale	Thickness
		Page	Quantity
		1/1	1/1

公差		精度	
最小	長度	(mm)	等級
1	~	4	-
4	~	16	-
16	~	63	-
63	~	250	-
250	~	1000	-